

Embedded Amplifier Photo Sensors

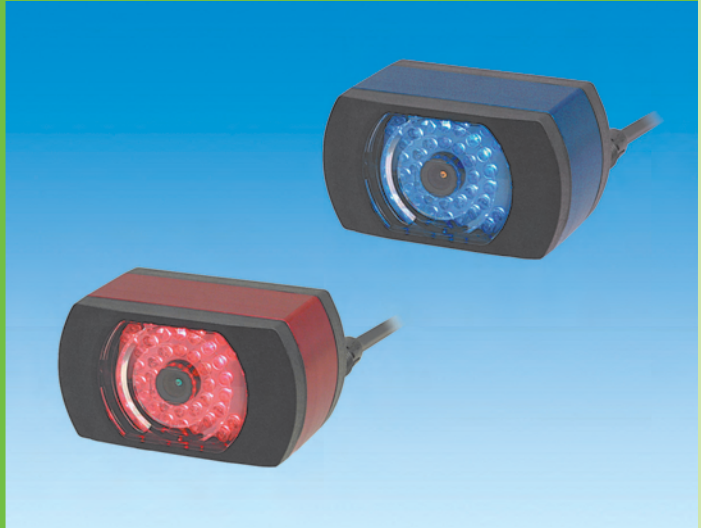





Embedded Amplifier Photo Sensors

- ASG Series
- UM2 Series
- GN Series
- UM Series
- Mini-G Series
- VS Series
- GA Series
- Middle-G Series
- NT Series
- CX Series
- DLZ Series
- GM Series
- LD-M/LD-S Series
- LD Series
- PF Series
- GA/NES Series
- NAL Series
- NE-DC Series
- NEF Series
- PU/AS Series

















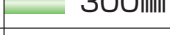
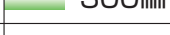

Embedded Amplifier Photo Sensors

List of models

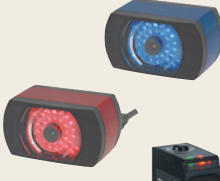
Type	Series	Appearance / Shape (typical example)	Detection method	Model	Detecting distance	See page
Glass detection	ASG		Diffuse-reflective type	ASG-S20R	20mm	170
			Limited reflection type	ASG-Z15R	3~15mm	
Ultra Miniature	UM2		Through-beam type	UM2-T15DT	150mm	172
				UM2-T15DTV		
				UM2-T50DT	500mm	
				UM2-T50DTV		
				UM2-T50DS		
				UM2-T50DSV		
			Limited reflection type	UM2-Z3SV	5~30mm	
				UM2-Z3DSV		
Compact for built-in use	GN		Through-beam type	GN-T10RS	10m	178
				GN-T10RS-J		
			Polarization reflector type	GN-M2RS	0.03~1.3m	
				GN-M2RS-J		
			Diffuse-reflective type	GN-R40RS	400mm	
				GN-R40RS-J		
Ultra Miniature	UM		Through-beam type	UM-T15DT	150mm	184
				UM-T15DTV		
				UM-T50DT	500mm	
				UM-T50DTV		
				UM-T50DS		
				UM-T50DSV		
				Diffuse-reflective type	UM-T100DT	
			UM-T100DS			
			UM-R3T		2~30mm	
			UM-R3TV			
			Diffuse-reflective type	UM-R5T	2~50mm	
				UM-R5TV		
			Limited reflection type	UM-Z3SV	5~30mm	

Embedded Amplifier Photo Sensors

List of models

Type	Series	Appearance / Shape (typical example)	Detection method	Model	Detecting distance	See page
Side-on	UM		Through-beam type	UM-T50DNS	 500mm	188
				UM-T50DNSV		
				UM-T50NS		
				UM-T50NSV		
Ultra compact/for embedded use	Mini-G		Through-beam type	GT1SN	 1m	190
				GT1N		
				GT3N	 7m	
				GT3RSN		
				GT7SN	 7m	
			Reflective type	GSM2RSN	 0.01~2m	
				Diffuse-reflective type	GS5SN	
			GS5N			
			GS20RSN		 400mm	
			GS20RN		 300mm	
			GS20SN		 300mm	
			GS20N		 200mm	
Limited reflection type	GSZ3SN	 1~40mm				
	GSZ3RSN	 3~30mm				
Compound-eye	VS		Diffuse-reflective type	VS-S20R	 80~200mm	196
				VS-S20B		
				VS-S50RNF	 100~500mm	
				VS-S50BNF		
Self-teaching	GA		Polarization reflector type	GA-M3R	 3m	202
			Diffuse-reflective type	GA-S05R	 500mm	











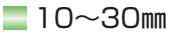











Embedded Amplifier Photo Sensors

List of models

Type	Series	Appearance / Shape (typical example)	Detection method	Model	Detecting distance	See page
Compact/for embedded use	Middle-G		Through-beam type	GT5RSN	7m	210
				GT5RSN-J		
				GT5RN		
				GT5RN-J		
			Polarization reflector type	GMR2RSN	0.3~1.5m	
				GMR2RSN-J		
				GMR2RN		
				GMR2RN-J		
			Diffuse-reflective type	GSR05RSN	500mm	
				GSR05RSN-J		
				GSR05RN		
				GSR05RN-J		
			Limited reflection type	GSZ5RS	20~50mm	
				GSZ5RS-J		
				GSZ5R		
				GSZ5R-J		
Die-cast	NT		Through-beam type	NT30F	30m	216
Cylindrical	CX		Through-beam type	CXT8	3m	220
			Polarization reflector type	CX-M2RD	2m	
			Diffuse-reflective type	CX-R01	100mm	
				CX-R03V	300mm	

Embedded Amplifier Photo Sensors

List of models

Type	Series	Appearance / Shape (typical example)	Detection method	Model	Detecting distance	See page
PCB detection	DLZ		Limited reflection type	DLZ-S30(D)	 10~30mm	224
	GM			GM-S/Z	 50mm	226
Red laser	LD-M		Polarization reflector type	LD-M10R	 3~15m	228
	LD-S		Diffuse-reflective type	LD-S20R	 80~300mm	
	LD		Through-beam type	LD-T20R	 20m	234
			Reflective type mark sensor	LD-S33R		
Resistance chemicals	PF		Through-beam type	PF-T3DS(S)	 3m	240
			Diffuse-reflective type	PF-R03S(DS)	 300mm	
Transparent objects	GA		Reflector type	GA-MT1R	 1m	244
	NES		Polarization reflector type	NES-MT1	 0.2~1m	248
				NES-MT1D		
Polarization	NAL		Polarization reflector type	NAL-M10RTC	 0.5~10m	250
For logistics facilities	NE-DC		Through-beam type	NE-T10RD-DC	 10m	254
				NE-T30D-DC	 30m	
			Polarization reflector type	NE-M5RD-DC	 0.03~5m	
	NEF		Diffuse-reflective type	NE-R10-DC	 1m	258
			Through-beam type	NEF-T10RD	 10m	
			Polarization reflector type	NEF-M5RD	 0.03~5m	
			Diffuse-reflective type	NEF-R50	 1m	

Embedded Amplifier Photo Sensors

List of models

Type	Series	Appearance / Shape (typical example)	Detection method	Model	Detecting distance		See page
U-shaped (address sensor)	PU		Through-beam type (U-shaped)	PU5	5mm fixed		260
				PU10	10mm fixed		
	AS-U20			19mm			
	AS-U20D						
	AS-U25			25mm fixed			
	AS-U25D						
	AS-U30			30mm fixed			
	AS-U30D						

Embedded Amplifier Photo Sensors

Applications

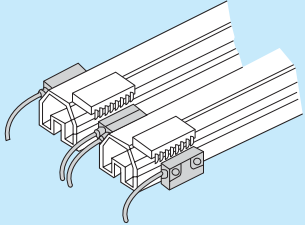
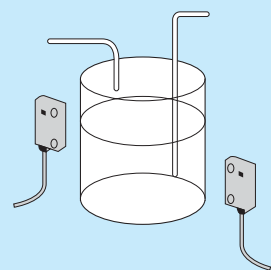
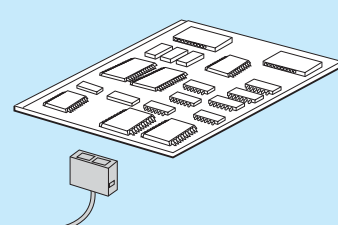
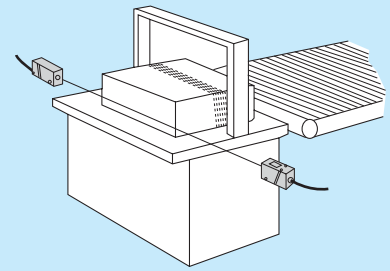
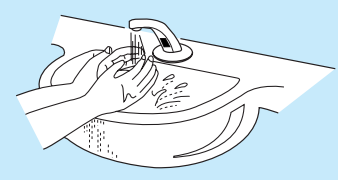
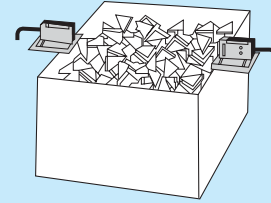
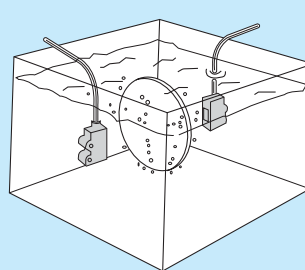
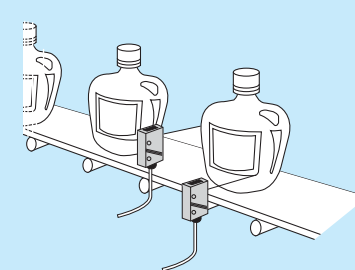
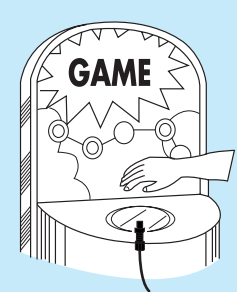
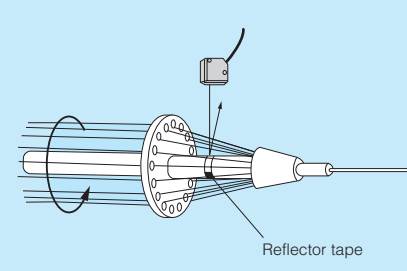
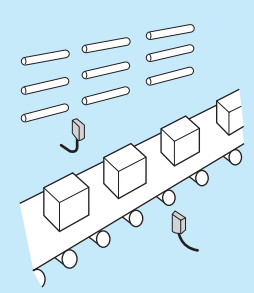
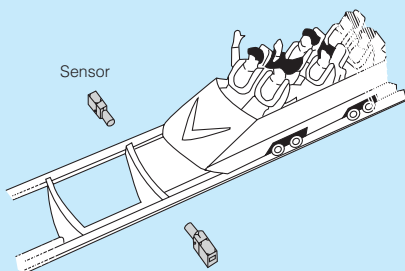
<ul style="list-style-type: none"> • Detection of ICs in transparent package 	<ul style="list-style-type: none"> • Checking amount of remaining resist liquid 	<ul style="list-style-type: none"> • Detection of pc boards on insertion machine 
<ul style="list-style-type: none"> • Detection of arrival of corrugated boards 	<ul style="list-style-type: none"> • Sensor for automatic faucet 	<ul style="list-style-type: none"> • Detection of press cuttings overflow 
<ul style="list-style-type: none"> • Detection of wafer in cleaning tank 	<ul style="list-style-type: none"> • Checking for displaced label 	<ul style="list-style-type: none"> • Sensor for game machine activation 
<ul style="list-style-type: none"> • Detection of wire strands (checking for broken thread)  <p>Reflector tape</p>	<ul style="list-style-type: none"> • Detection of object under strong ambient light  <p>Inverter fluorescent lamp</p>	<ul style="list-style-type: none"> • Detection of passage of roller coaster  <p>Sensor</p> <p>Safety measures for system as a whole required</p>



- Reliably detects inclined transparent glass
Ideal for flush-mounting in robot end-effector.
- Unique optical system allows stable detection regardless of warpage or inclination of glass
Unprecedented reliability in inclined object detection is realized by the use of two red LED light sources
- Thin (4mm) embedded amplifier photo sensor
Counterbores for M3 countersunk screws convenient for flush-mounting in robot end-effector.

Type

Detection method	Detecting distance	Model	Operation mode	Output mode
Diffuse-reflective type	20mm	ASG-S20R	Light-ON	NPN Open collector
Limited reflection type	3~15mm	ASG-Z15R		

Applications

Sensor flush-mounted in robot End-Effector
Photo sensor of only 4 mm in thickness flush-mounted in robot hand for detecting the presence of liquid crystal glass.

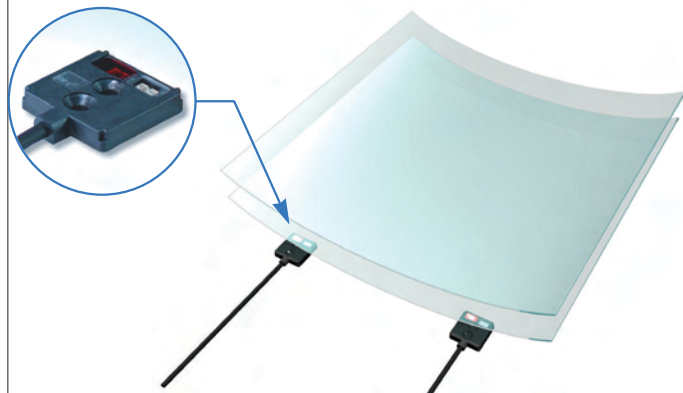

Optical system employing two LEDs as light sources.
Used for reliable detection of inclined or warped glass.

Difference between ASG-S20R and ASG-Z15R

- ASG-S20R is a diffuse-reflective type sensor with a wide activation range.
If the detected glass is warped, the detecting distance can be 25 mm at maximum.
- ASG-Z15R is a limited zone-reflective sensor with a wide activation range.
If the glass to detect is warped, the detecting distance can be 18 mm at maximum. The sensor is not activated by transparent glass in contact with the sensor.

Rating/Performance/Specification

Type		ASG-S20R	ASG-Z15R
Detection method		Diffuse-reflective sensor for glass detection	Limited zone-reflective sensor for glass detection
Detection object		Transparent glass	
Detecting distance		Transparent glass 20mm max. 25 mm max. (*)	Transparent glass 3 - 15 mm 18 mm max. (*)
Power supply		12~24V DC ±10% / Ripple 10% max.	
Light source		2 red LEDs	
Current consumption		25 mA max.	
Operation mode		Light-ON	
Output mode	Control output	NPN open collector output	
	Rating	Sink current 50 mA (30 VDC max.)	
Short circuit protection		Provided	
Indicator		Operation indicator : orange LED	
Response time		0.5 ms max.	
Connection		Permanently attached cord (0.15 sq. 3 core 2m length)	
Mass		Approx. 30 g	

(*) The maximum distance means the distance to the farthest part of an inclined transparent glass. This sensor does not have a sensitivity adjustment volume and must be used with no object interfering with the detection in the surrounding area.

Environmental Specification

Ambient light	5,000 lx max.
Ambient temperature	-10 - +55 -C (non-freezing)
Ambient humidity	35~85%RH (non-condensing)
Vibration	10 - 55 Hz / 1.5 mm amplitude / 2 hours each in 3 directions
Protective structure	IP40

Activation Position Characteristics (Typical Example)

ASG-S20R

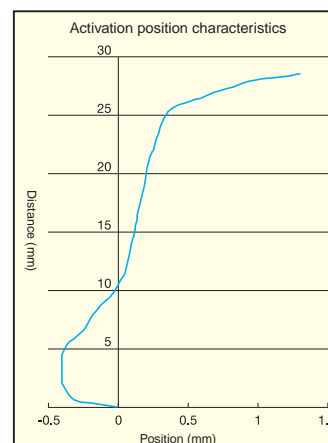

ASG-Z15R

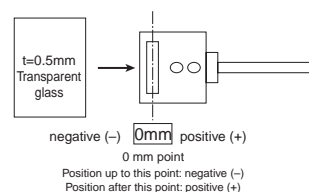
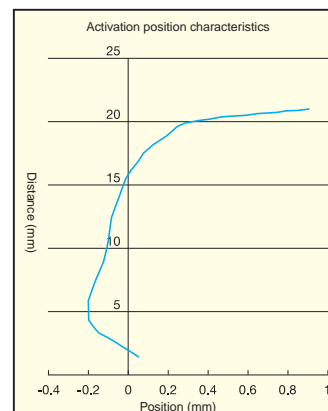

Input/Output Circuit and Connection

NPN output

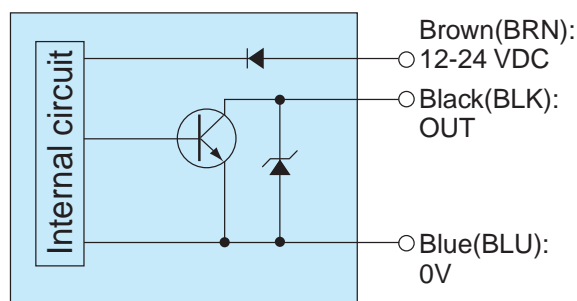

- The output transistor turns off when load short circuit or overload occurs. Check the load and turn the power back on.

Dimensions (in mm)

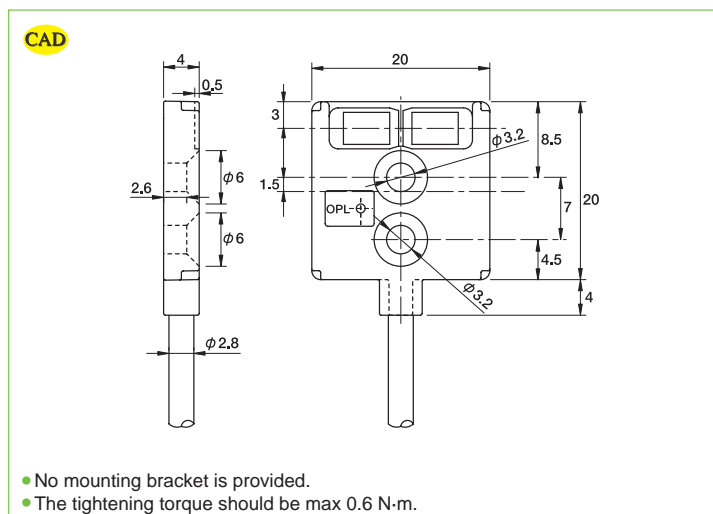



- Highly-advanced type of ultra miniature sensor
- High-intensity indicator and red LED light source
Allows long distance checking of both sensor operation and light transmission.
- NPN and PNP output types are available
- Excellent water resistance to IP 67 standard
Sensor allows washing with water.

Type

Detection method	Detecting distance	Model	In-line sensitivity adjustment volume	Operation mode	Output mode
 Through-beam type	 150mm	UM2-T15DT	—	Dark-ON (Contact Takex for Light-ON type.)	NPN Open collector (Contact Takex for PNP-output type.)
		UM2-T15DTV	Provided		
	 500mm	UM2-T50DT	—		
		UM2-T50DTV	Provided		
		UM2-T50DS	—		
		UM2-T50DSV	Provided		
 Limited reflection type	 5~30mm	UM2-Z3SV	Provided	Light-ON	
		UM2-Z3DSV		Dark-ON	

- In-line sensitivity adjustment allows for wider range of applications
Models with space-saving and easy-to-use in-line volume adjustment are available.



- Length of cord between sensor (receiver) and in-line sensitivity adjustment : 300 mm (fixed)
- Mounting bracket (separately available): model UM-V2

Rating/Performance/Specification

Type		UM2-T15DT	UM2-T15DTV	UM2-T50DT	UM2-T50DTV	UM2-T50DS	UM2-T50DSV	UM2-Z3SV	UM2-Z3DSV		
Rating/performance	Detection method	Through-beam type						Limited reflection type			
	Detecting distance	150mm			500mm			5 - 30mm*			
	Detection object	φ 2mm (Min.) Opaque			φ 3mm (Min.) Opaque			—			
	Power supply	24V DC ±10% / Ripple 10% max. *1						12 - 24V DC ±10%/ Ripple 10% max.			
	Current consumption	Transmitter	15mA max.						26mA max.	30mA max.	
		Receiver	15mA max.	22mA max.	15mA max.	22mA max.	15mA max.	22mA max.			
	Output mode	NPN open collector Rating: sink current 80 mA (30 VDC) max. (PNP output type also available. *2)									
	Operation mode	Dark-ON						Light-ON	Dark-ON		
	Response time	0.5ms max									
	Operating angle	15° (at receiver)						—			
Hysteresis	—						Up to 10% of detecting distance				
Specification	Light source (light wavelength)	Red LED (660nm)									
	Indicator	Operation indicator (orange LED)— For through-beam type, provided on receiver. Stability indicator (green LED)									
	Volume (VR)	—	In-line sensitivity adjustment	—	In-line sensitivity adjustment	—	In-line sensitivity adjustment				
	Material	Case	ABS resin								
		Lens	Acrylic resin								
	Connection	Permanently attached cord (outer dimension: dia. 2.8)									
		Transmitter: 0.15sq. 2 core 2 m length (gray) Receiver: 0.15sq. 3 core 2 m length (black)						0.15sq. 3 core 2 m length (black)			
	Mass	Transmitter	Approx. 30g						Approx. 40g		
		Receiver	Approx. 30g	Approx. 40g	Approx. 30g	Approx. 40g	Approx. 30g	Approx. 40g			
	Accessory	Mounting screws, washers, nuts (material: Fe), screwdriver for adjustment (provided for models with adjustment volume only), operation manual									
Notes	*Standard detection object: 50 x 50 mm white drawing paper *1 12 VDC type also available. *2 PNP output type models identified by XPE at the end of model number. Comes with output conversion unit.										

Environmental Specification

Environment	Ambient light	3,000 lx max.
	Ambient temperature	-25 - +55 -C (non-freezing)
	Ambient humidity	35 - 85%RH (non-condensing)
	Protective structure	IP67
	Vibration	10 - 55 Hz / 1.5 mm amplitude / 2 hours each in 3 direction

● Applicable power supply unit

PS series
High capacity of 200 mA at 12 VDC



(General-purpose type) PS3N
PS3N-SR
(Multifunctional type) PS3F
PS3F-SR

Input/Output Circuit and Connection

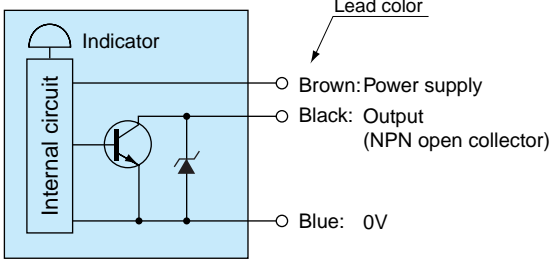
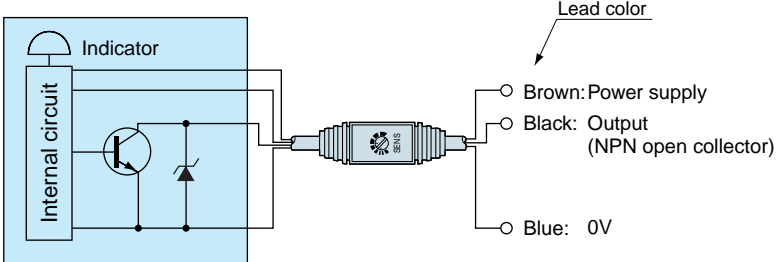
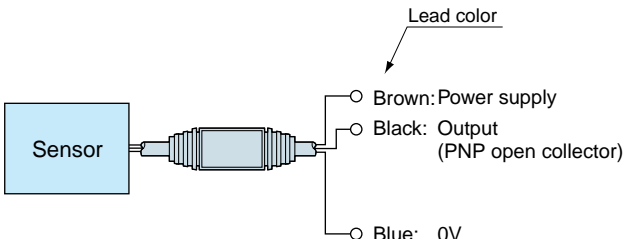
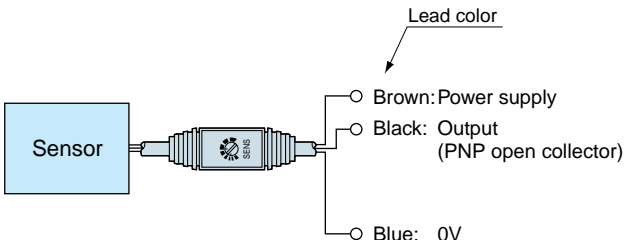
Model	Input/output circuit and connection
<p>NPN output type</p> <p>UM2-T15DT UM2-T50DT UM2-T50DS</p>	 <p>The transmitter is provided with power supply lines (brown: operating power; blue: 0 V) only.</p>
<p>NPN output type with in-line sensitivity adjustment</p> <p>UM2-T15DTV UM2-T50DTV UM2-T50DSV UM2-Z3SV UM2-Z3DSV</p>	 <p>The transmitter is provided with power supply lines (brown: operating power; blue: 0 V) only.</p>
<p>PNP output type</p> <p>UM2-T15DTP UM2-T50DTP UM2-T50DSP</p>	<p>PNP open collector output available with in-line output conversion unit.</p>  <p>The transmitter is provided with power supply lines (brown: operating power; blue: 0 V) only.</p>
<p>PNP output type with in-line sensitivity adjustment</p> <p>UM2-T15DTVP UM2-T50DTVP UM2-T50DSVP UM2-Z3SVP UM2-Z3DSVP</p>	<p>PNP open collector output available with in-line volume/output conversion unit.</p>  <p>The transmitter is provided with power supply lines (brown: operating power; blue: 0 V) only.</p>

Characteristics (Typical Example)

Directional characteristics

UM2-T15DT · UM2-T15DTV

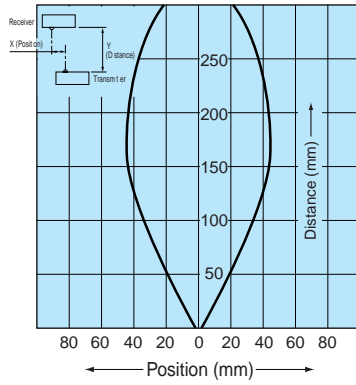

UM2-T50DT · UM2-T50DTV

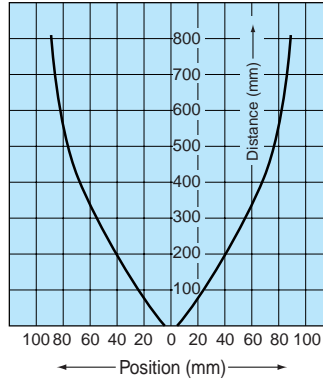

UM2-T50DS · UM2-T50DSV

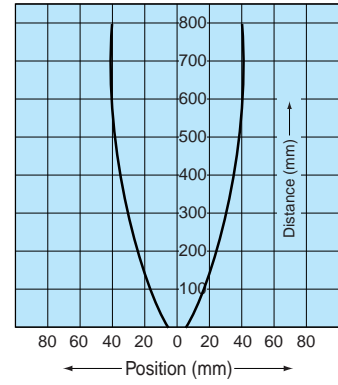

Operating angle characteristics

UM2-T15DT · UM2-T15DTV

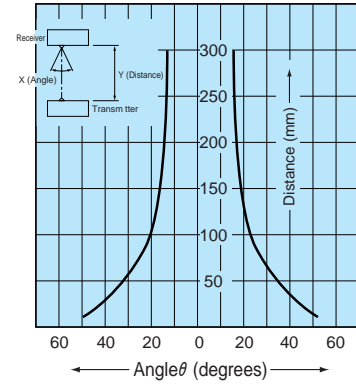

UM2-T50DT · UM2-T50DTV

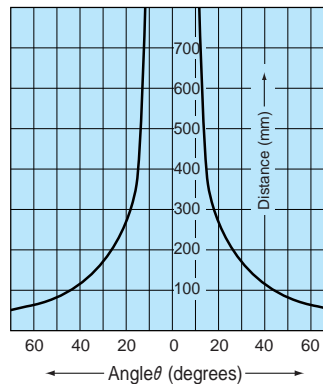

UM2-T50DS · UM2-T50DSV

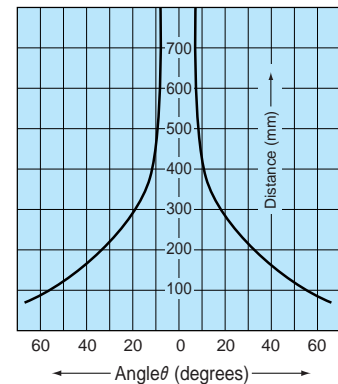

Activation area characteristics

UM2-Z3SV · UM2-Z3DSV

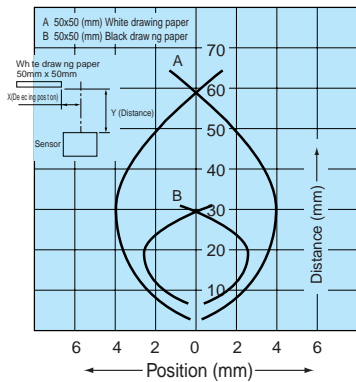

Distance-area characteristics

UM2-Z3SV · UM2-Z3DSV

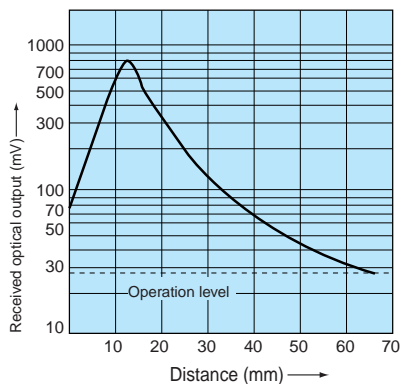

For Correct Use

Be sure to follow the instructions in the operation manual provided for correct use of the product.



- Do not use the product for detection for the protection of human body.
- When using the product for safety purposes, ensure safety with the control system as a whole as well as the detection.
- This product is not explosion proof.

About indicators

- The operation indicator (orange LED) and stability indicator (green LED) show the levels of light intensity as described in the figure below.
- After aligning the optical axis and adjusting the sensitivity, use a detection object to block and unblock the light beam several times to make sure that the sensitivity level is in a range that allows stable activation and deactivation. Setting the sensitivity in a range allowing stable operation achieves higher reliability against changes in the operating environment generated after the sensitivity is set.

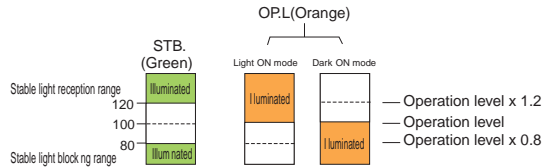

- The orange LED (OP.L) is the operation indicator. In the L.ON (light ON) mode, the indicator is illuminated when a certain amount of light is detected. In the D.ON (dark ON) mode, the indicator is illuminated when a certain amount of light is not detected.

Operation timing chart

Light-ON mode

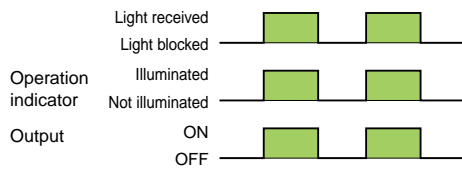

Dark-ON mode

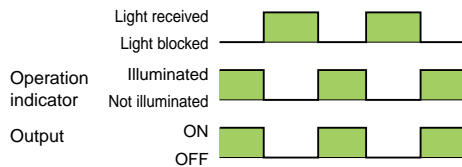

Sensor mounting and adjustment

- No mounting bracket is provided.
- For mounting, use the M2 x 10 screws, washers and nuts provided. The tightening torque should not exceed 0.3 N·m. Excessively high torque may damage the sensor.
- The models with an in-line volume allows sensitivity adjustment when light is not adequately blocked due to translucent or small objects in detection with a through-beam-type sensor or when any influence of the background must be avoided or the amount of reflected light is small in detection with a reflective-type sensor. Turning the volume counterclockwise reduces the sensitivity.

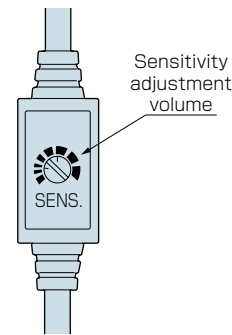

Notes on usage

- Avoid use in which the power is turned on and off consecutively.
- For output, avoid the transient condition immediately after power-up (50 ms).
- To extend the cord, use thick wires (at least 0.3 mm²) and limit their length to within 50 m whenever possible. Take voltage drop into consideration when the length exceeds 50 m.
- Be sure to route the sensor lines separately from any power transmission or high-voltage line. Using the same conduit or duct may cause electric induction, which leads to faulty operation or damage.

Dimensions (in mm)

UM2-T15DT
 UM2-T15DTV (sensor)
 UM2-T50DT
 UM2-T50DTV (sensor)

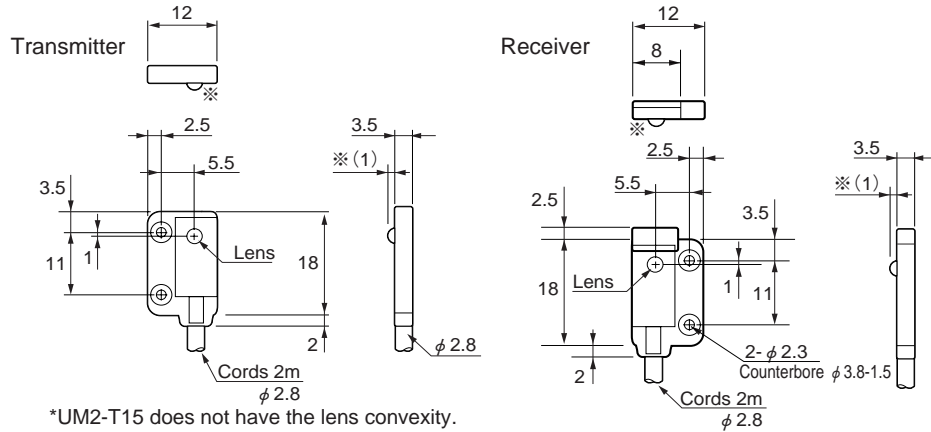

(M2 x 10 mm screws, nuts,
 internal toothed washers provided.)

UM2-T50DS
 UM2-T50DSV (sensor)

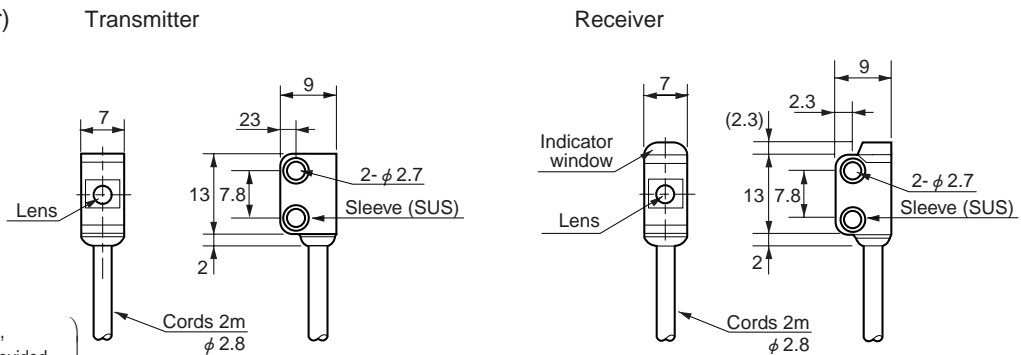

(M2.6 x 12 mm screws, nuts,
 internal toothed washers provided.)

UM2-Z3SV (sensor)
 UM2-Z3DSV (sensor)

(M2.6 x 12 mm screws, nuts,
 internal toothed washers provided.)

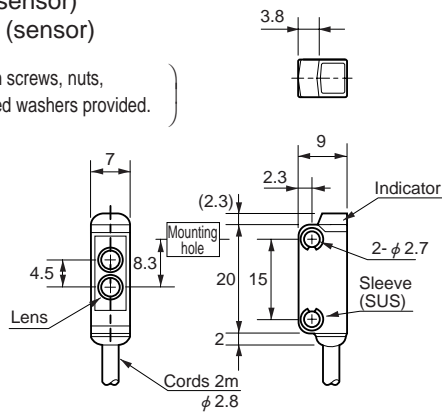

● In-line sensitivity adjustment volume/PNP output conversion unit
 Provided in the receiver cord for through-beam model.

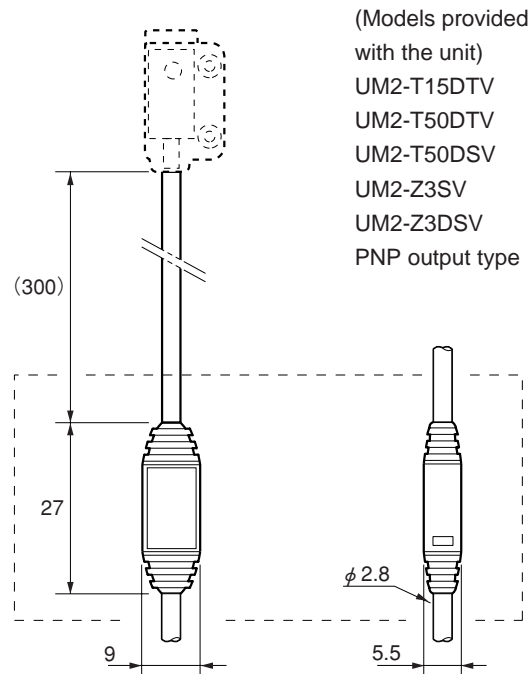

● For mounting, directly screw onto the surface.
 The tightening torque should be up to 0.3 N·m.



- New type of amplifier built-in photo sensor
- Slim and compact side-on models
 - Lightweight and compact
Thin, space-saving sensor allowing flexible mounting
 - Flat lens less affected by dust or dirt attached
Superb stability with the high power (detecting distance of 10 m)
 - High-intensity indicators for increased visibility
Easy checking of sensor operation from a distance

Type

Detection method	Detecting distance	Model		Operation mode	Output mode
		NPN type	PNP type		
Through-beam type	10m	GN-T10RS	GN-T10RSPN	Light-ON/Dark-ON selectable (with switch)	Open collector
Polarization reflector type	0.03~1.3m	GN-M2RS	GN-M2RSPN		
Diffuse-reflective type	400mm	GN-R40RS	GN-R40RSPN		

- Infrared LED type
For the through-beam and diffuse-reflective models, types that employ infrared LED as the light source are available.
For details, see Rating/Performance/Specification.
- M8 connector type
M8 connector connection types are available for all models.
For details, see Rating/Performance/Specification.
For connector specifications, see p. 180.

Optional Parts

Type	Model	Pinhole diameter	Detecting distance with plate/filter attached		
		Direction of polarization	Red LED	Infrared LED	
For through-beam type only	Pinhole plate	GNP1	φ 1mm	400mm	300mm
		GNP2	φ 2mm	1m	1m
		GNP3	φ 3mm	3m	2.5m
		GNP5-1	5 × 1mm	2m	1.7m
	Interference prevention filter	GN-PFA	Longitudinal	5m (Applicable to red LED type only)	
GN-PFB		Horizontal			

Type	Model	Shape
Cord with M8 connector	FBC-4R2S	Straight (2 m)
	FBC-4R2L	Angled (2 m)



M8 connector type

Rating/Performance/Specification

Type	Permanently attached cord	NPN type	GN-T10RS	GN-T7S	GN-M2RS	GN-R40RS	GN-R30S	GN-R7S
		PNP type	GN-T10RSPN	GN-T7SPN	GN-M2RSPN	GN-R40RSPN	GN-R30SPN	GN-R7SPN
	Connector	NPN type	GN-T10RS-J	GN-T7S-J	GN-M2RS-J	GN-R40RS-J	GN-R30S-J	GN-R7S-J
		PNP type	GN-T10RSPN-J	GN-T7SPN-J	GN-M2RSPN-J	GN-R40RSPN-J	GN-R30SPN-J	GN-R7SPN-J
Detection method		Through-beam type			Polarization reflector type	Diffuse-reflective type		
Detecting distance		10m	7m	0.03~1.3m *1	400mm	300mm	70mm	
Detection object		φ 6mm (Min.) Opaque			Glossy objects including mirror-like materials and stainless-steel plates or Opaques	Standard detection object: 200 x 200 mm white drawing paper		Standard detection object: 100 x 100 mm white drawing paper
Power supply		12-24V DC ±10% / Ripple 10% max.						
Current consumption		Transmitter: 22mA max. Receiver: 15mA max.			25mA max.			
Output mode	Control output	NPN type	Rating: sink current 100 mA (30 VDC max.) / Residual voltage: 1 V or less					
		PNP type	Rating: source current 100 mA (30 VDC max.) / Residual voltage: 2 V or less					
	Stability output	NPN type	Rating: sink current 50 mA (30 VDC max.) / Residual voltage: 1 V or less					
		PNP type	Rating: source current 50 mA (30 VDC max.) / Residual voltage: 2 V or less					
Operation mode		Light-ON/Dark-ON selectable (with switch)						
Anti Interference feature		—————			Provided (operation may be affected depending on the setting)			
Response time		0.5ms max.						
Operating angle		10° (at receiver)			30° (at reflector)	—————		
Hysteresis		—————			10% max.			
Light source (light wavelength)		Red LED (700nm)	Infrared LED (880nm)	Red LED (640nm)		Infrared LED (880nm)		
Indicator		Transmitter: Power indicator (orange LED) Receiver: Operation indicator (orange LED) Stability indicator (green LED)			Operation indicator (orange LED) Stability indicator (green LED)			
Volume (VR)		Sensitivity adjustment (on receiver for through-beam type)						
Switch (SW)		Light-ON/Dark-ON selector switch						
Short circuit protection		Provided for control output and stability output						
Material	Case	Polybutylene terephthalate						
	Lens	Methacrylate						
Connection	Permanently attached cord	Permanently attached cord (outer dimension: dia. 3.5) Transmitter 0.2sq. 2 core 2 m length (gray) Receiver 0.2 sq. 4 core 2 m length (black)			Permanently attached cord (outer dimension: dia. 3.5) 0.2sq. 4 core 2 m length (black)			
	Connector	M8 connector (cord with M8 connector separately available)						
Mass	Permanently attached cord	Transmitter/receiver: approx. 60g			Approx. 60g			
	Connector	Transmitter/receiver: approx. 10g			Approx. 10g			
Accessory		—————			K-71 reflector	—————		
Screwdriver for sensitivity adjustment, operation manual, mounting bracket GN-B1 (provided for permanently attached cord type only)								

*1 The distance with use of K-7 (separately available) is 0.01 - 2 m.

Environmental Specification

Ambient light	5,000 lx max.
Ambient temperature	-25 - +55 -C (non-freezing)
Ambient humidity	35 - 85%RH (non-condensing)
Protective structure	IP67
Vibration	10 - 55 Hz / 1.5 mm amplitude / 2 hours each in 3 direction
Dielectric strength	AC1000V 1 min.
Insulation resistance	500 VDC, 20 MΩ or higher
Shock	500 m/s ² / 3 times each in 3 directions

• Applicable power supply unit

PS series
High capacity of 200 mA at 12 VDC



(General-purpose type) PS3N
PS3N-SR
(Multifunctional type) PS3F
PS3F-SR

Input/Output Circuit and Connection

Transmitter of through-beam type

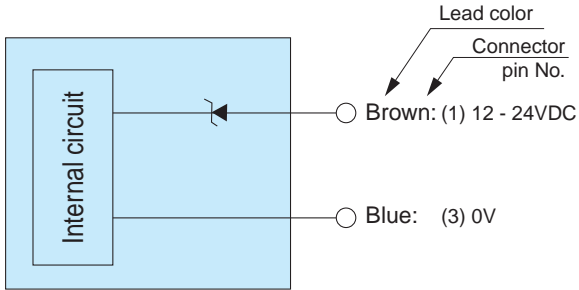

Receiver of through-beam type/polarization reflector type/diffuse-reflective type

NPN output type

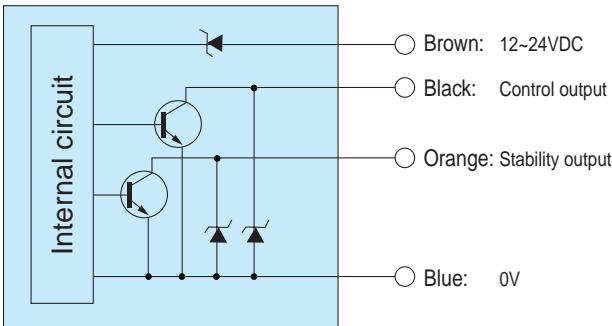

PNP output type

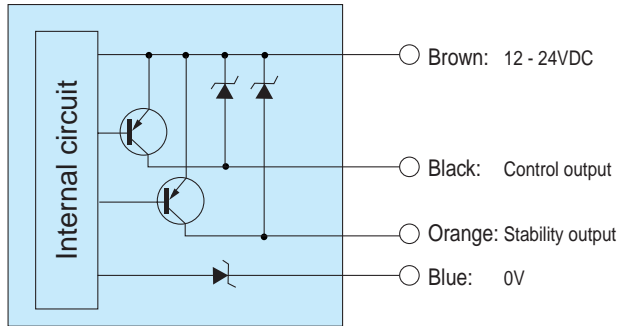

- The output transistor turns off when load short circuit or overload occurs. Check the load and turn the power back on. To extend the cord, use thick wires (at least 0.3 mm²).

Connector type pin assignment and connection

(Sensor)

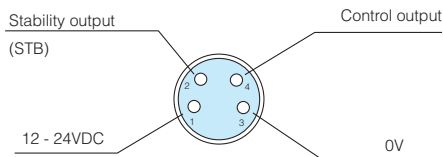

(Cord with M8 connector)

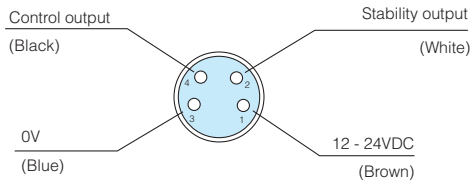

Lead color	Pin No.	Function
Brown	1	12 - 24 VDC
White	2	STB output
Blue	3	0V
Black	4	Control output

Cord with M8 connector (optional)

(in mm)

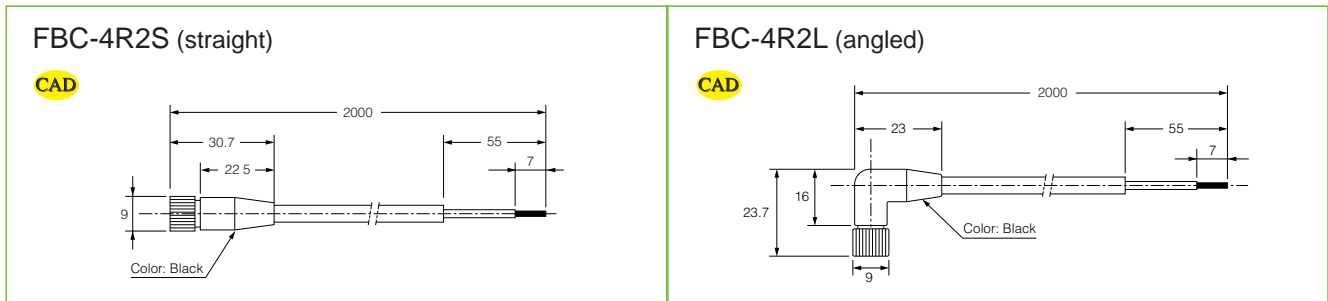

Characteristics (Typical Example)

Through-beam type GN-T10RS (PN) (-J)

• Directional characteristics

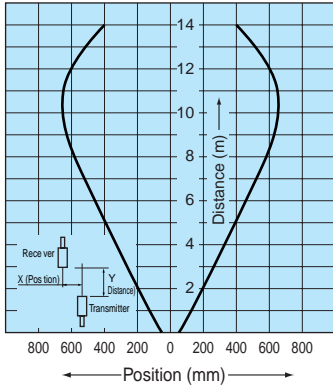

• Operating angle characteristics

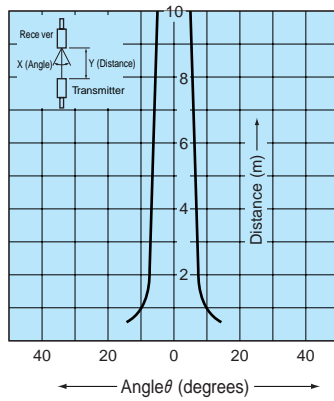

• Temperature characteristics

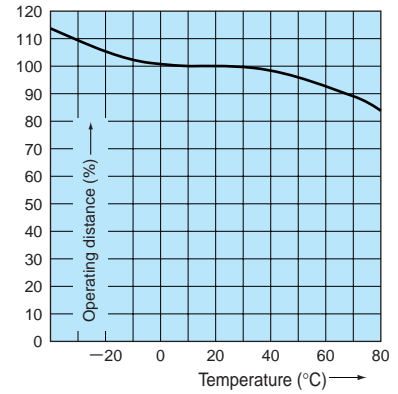

Polarization reflector type GN-M2RS (PN) (-J)

• Directional characteristics

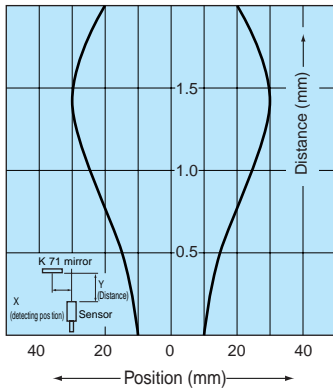

• Operating angle characteristics

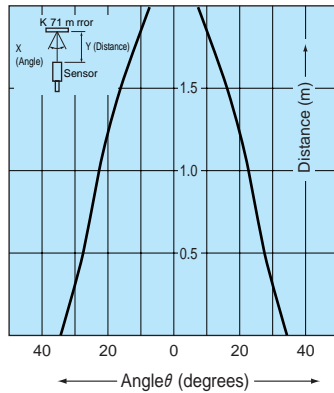

Diffuse-reflective type GN-R40RS (PN) (-J)

• Activation area characteristics

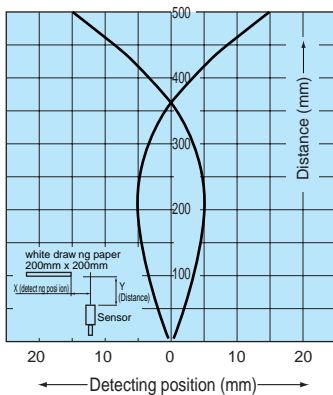

• Distance-area characteristics

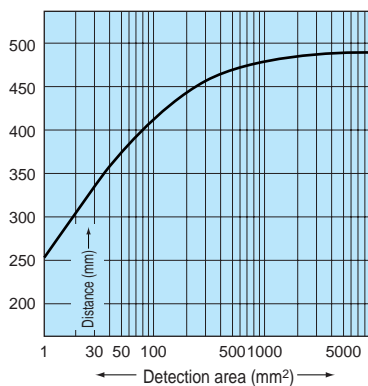

• Temperature characteristics

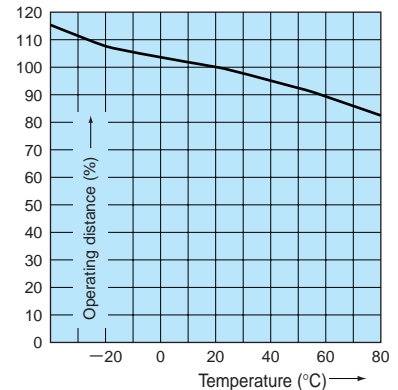

For Correct Use

Be sure to follow the instructions in the operation manual provided for correct use of the product.



- Do not use the product for detection for the protection of human body.
- When using the product for safety purposes, ensure safety with the control system as a whole as well as the detection.
- This product is not explosion proof.

About indicators

- The operation indicator (orange LED) and stability indicator (green LED) show the levels of light intensity as described in the figure below.
- After aligning the optical axis and adjusting the sensitivity, use a detection object to block and unblock the light beam several times to make sure that the sensitivity level is in a range that allows stable activation and deactivation. Setting the sensitivity in a range allowing stable operation achieves higher reliability against changes in the operating environment generated after the sensitivity is set.

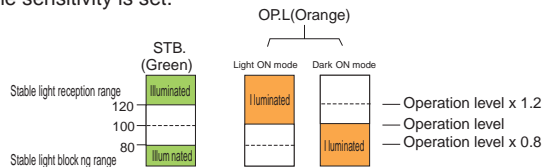

- The orange LED (OP.L) is the operation indicator. In the L.ON (light ON) mode, the indicator is illuminated when a certain amount of light is detected. In the D.ON (dark ON) mode, the indicator is illuminated when a certain amount of light is not detected.

Stability output

The stability output can be used to check for reduction of the light intensity level along with any change in the operating environment or operation over time or to perform initial check of the operation. When two consecutive detections have occurred with the intensity of light detected exceeding the operation level but not reaching 120 % of the level (range allowing stable operation), the stability signal is output when the control output is deactivated.

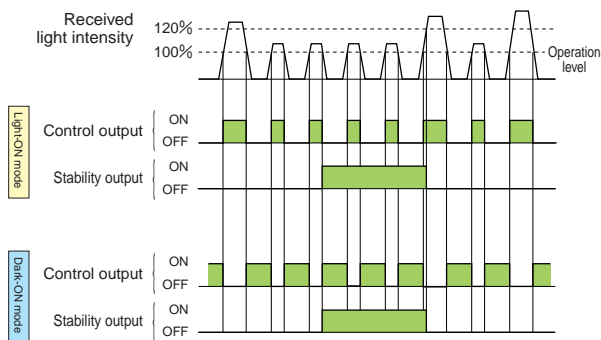

Reflector of polarization reflector type

The detection distance varies depending on the reflector model used.

Reflector model	K-71	K-7	S-25
Detecting distance	0.03 - 1.3m	0.01 - 2m	50 - 600mm
Remarks	Accessory	Optional	Optional

Mounting of sensor

The tightening torque for mounting screws should not exceed 0.6 N·m.

Switching between light ON and dark ON and setting sensitivity

(For the light ON mode)
Turn the switch to L.ON.

(For the dark ON mode)
Turn the switch to D.ON.



Light-ON/Dark-ON selector (white)

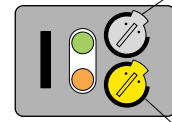

Sensitivity adjustment volume (yellow)

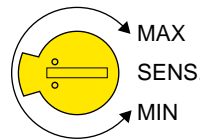

Sensitivity can be adjusted for detection with a transmission-type model in which blocking of the light beam is inadequate due to a translucent or small object or for detection with a reflection-type model in which any influence of the background should be avoided or the sensor must detect low intensity of reflected light. Turning the volume counterclockwise reduces the sensitivity.

For setting the light ON/dark ON switch (white) and adjusting the sensitivity volume (yellow), use the adjustment screwdriver supplied and turn carefully. Turning the volumes with excessive force may damage the volumes.

About pinhole plate

Pinhole plates allow the reduction of the size of a detection object or the margin of movement. Using the sensitivity adjustment volume in combination allows detection of even smaller or near-transparent objects.

Interference prevention filters

When two sensors are mounted close to or in contact with each other, interference prevention filters can be used to avoid faulty operation caused by mutual-interference. Interference prevention filters can be used only for transmission-type sensors emitting red light.

Attachment of pinhole plate /interference prevention filter

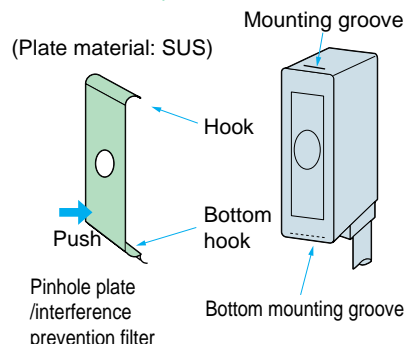

Put a hook of the plate on the mounting groove at the top of the sensor and press the bottom of the plate in until it clicks.

Dust, drops of water, etc. in the pinhole or the filter may cause faulty operation.

Dimensions (in mm)

All permanently attached cord model

CAD

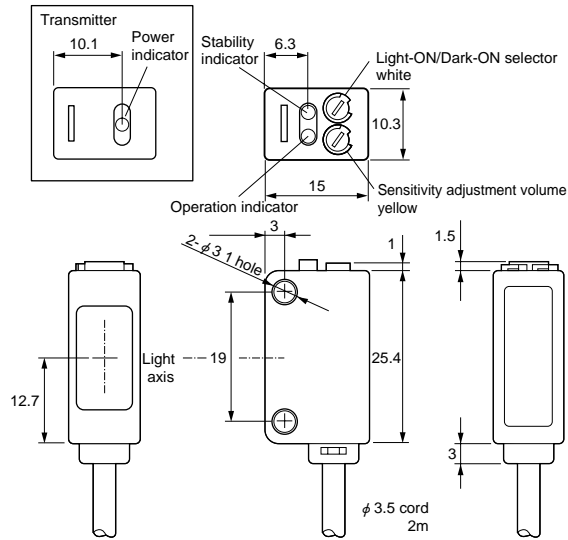

All connector connection (-J) models

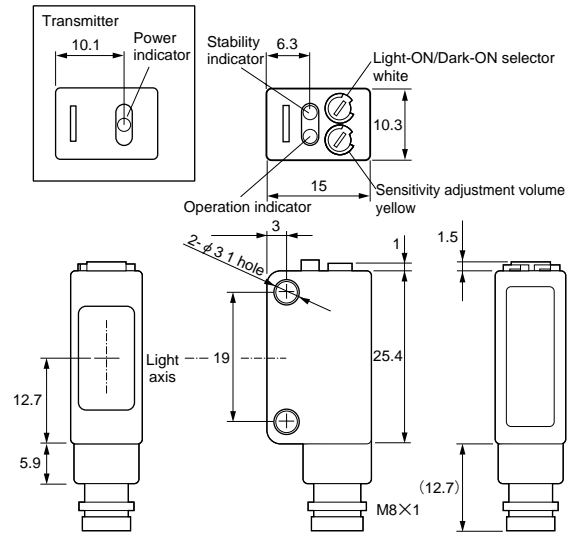

(Mounting brackets do not come with connector types.)

All permanently attached cord models

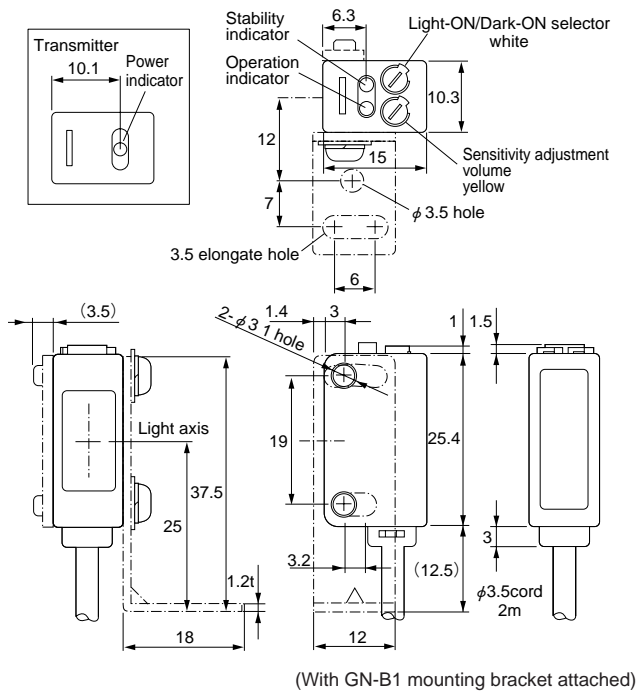

Reflector K-71

CAD

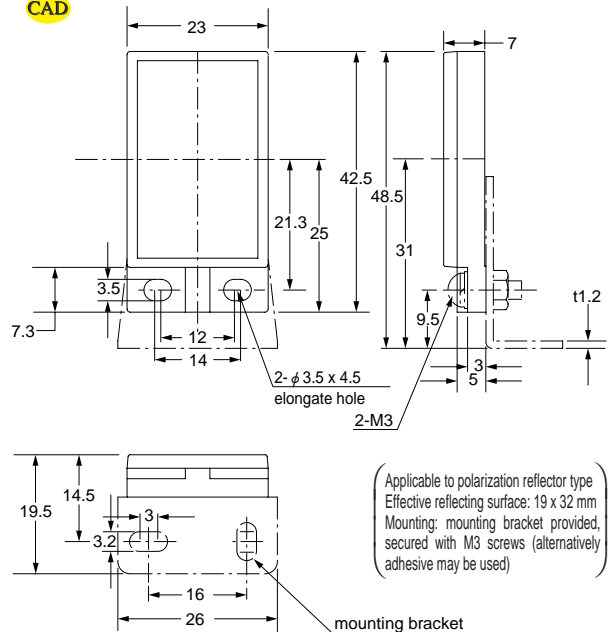

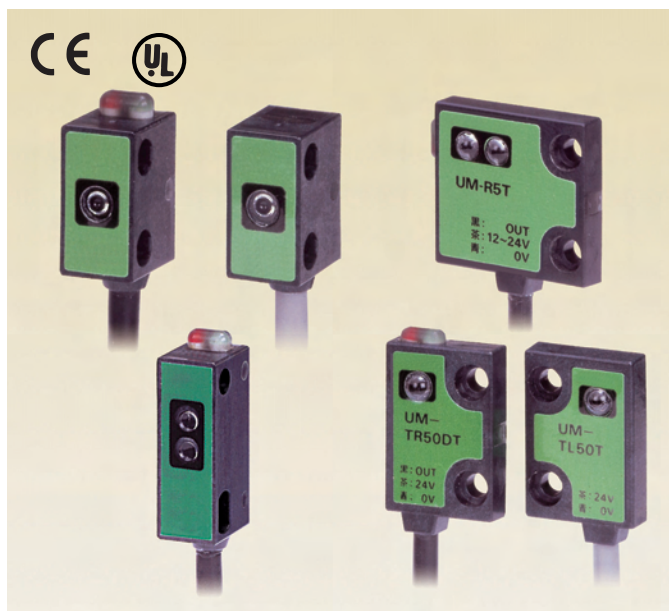

- Ultra miniature size (extra thin, extra compact)
- Long distance detecting up to 1 m
- Ideal for integrating into small devices
 - Thinness of 3.5 mm achieved with embedded amplifier type!
 - Extremely small volume: less than 0.8 cm³
 - Volume fraction: about 1/5 (to conventional Takex product)
 - Low cost
 - Red LED light source allows checking of emitted light spot
 - Equipped with stability and operation indicators
 - Wide range of applications from small-scale FA to system wide FA

Type

Detection method	Detecting distance	Model	In-line sensitivity adjustment volume	Operation mode	Output mode
Through-beam type (↑)	150mm	UM-T15DT	—	Dark-ON (Contact Takex for Light-ON type.)	NPN Open collector
		UM-T15DTV	Provided		
	500mm	UM-T50DT	—		
		UM-T50DTV	Provided		
		UM-T50DS	—		
	1m	UM-T100DT	—		
		UM-T100DS	—		
Polarization reflector type (↕)	2~30mm	UM-R3T	—	Light-ON (Contact Takex for Dark-ON type.)	Contact Takex for PNP-output type.
		UM-R3TV	Provided		
	2~50mm	UM-R5T	—		
		UM-R5TV	Provided		
Diffuse-reflective type (∇)	5~30mm	UM-Z3SV	Provided		

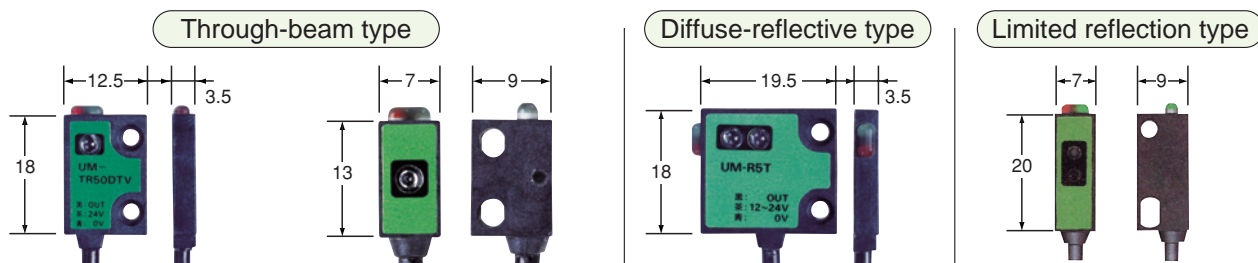

Rating/Performance/Specification

Type		UM-T15DT	UM-T15DTV	UM-T50DT	UM-T50DTV	UM-T50DS	UM-R3T	UM-R3TV	UM-R5T	UM-R5TV	UM-Z3SV		
Rating/Performance	Detection method	Through-beam type					Diffuse-reflective type					Limited reflection type	
	Detecting distance	150mm		500mm (*1m)			2 - 30mm *1		2 - 50mm*1		5 - 30mm *1		
	Detection object	φ 3mm (Min.) Opaque											
	Power supply	24V DC ±10% / Ripple 10% max. *2					12 - 24V DC ±10% / Ripple 10% max.						
	Current consumption	Transmitter	15mA max.					20mA max.	27mA max.	20mA max.	27mA max.	27mA max.	
		Receiver	15mA max.	22mA max.	15mA max.	22mA max.	15mA max.						
	Output mode	NPN open collector Rating: sink current 80 mA (30 VDC) max. (PNP output type also available.)											
	Operation mode	Dark-ON					Light-ON						
	Response time	0.5ms max.											
	Operating angle	25°											
Hysteresis						Up to 10% of detecting distance							
Specification	Light source (light wavelength)	Red LED (660nm) (*Infrared LED)											
	Indicator	Operation indicator (red LED)— For through-beam type, provided on receiver. Stability indicator (green LED)											
	Volume		In-line sensitivity adjustment *3		In-line sensitivity adjustment *3	*4		In-line sensitivity adjustment *3		In-line sensitivity adjustment *3	In-line sensitivity adjustment *3		
	Material	Case	Liquid crystalline polyester (filler: polypropylene)										
		Lens	Acrylic resin				ABS resin	Acrylic resin				ABS resin	
	Connection	Permanently attached cord (outer dimension: dia. 2.8)											
	Mass	Transmitter	Approx. 30g	Approx. 30g	Approx. 30g	Approx. 30g	Approx. 30g	Approx. 30g	Approx. 40g	Approx. 30g	Approx. 40g	Approx. 40g	
		Receiver	Approx. 30g	Approx. 40g	Approx. 30g	Approx. 40g	Approx. 30g						
Notes	*1 Standard detection object: 50x 50 mm white drawing paper *2 12 VDC type also available. *3 Length of cord between sensor and in-line sensitivity adjustment volume: 30 cm (fixed) *4 Model with in-line sensitivity adjustment volume available												

*Models with detecting distance of 1 m are also available (infrared LED used as light source).
For model numbers, see "Type."

Environmental Specification

Environment	Ambient light	3,000 lx max.
	Ambient temperature	-25 - +55 -C (non-freezing)
	Ambient humidity	35-85%RH (non-condensing)
	Protective structure	IP64
	Vibration	10 - 55 Hz / 1.5 mm amplitude / 2 hours each in 3 direction

Applicable power supply unit

PS series

High capacity of 200 mA at 12 VDC

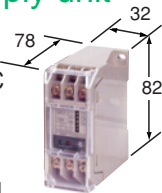

- (General-purpose type) PS3N
PS3N-SR
- (Multifunctional type) PS3F
PS3F-SR

Input/Output Circuit and Connection

(Shows receiver of through-beam type as typical example. Power supply for reflective type: 12-24 VDC.)

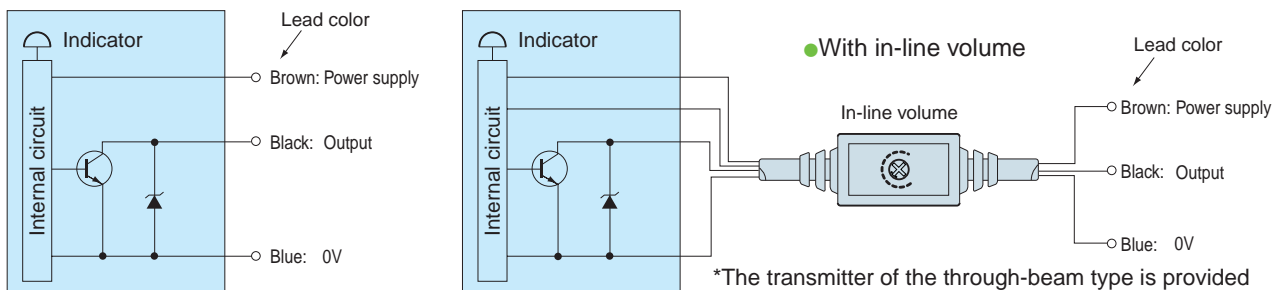

*The transmitter of the through-beam type is provided with power supply lines (brown: 24 VDC; blue: 0 V) only.

Characteristics (Typical Example)

Directional characteristics

UM-T15DT·UM-T15DTV

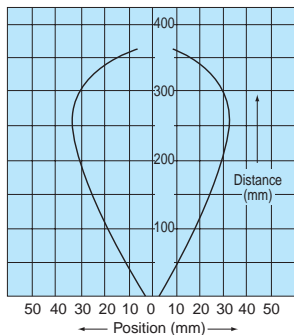

UM-T50DT·UM-T50DTV

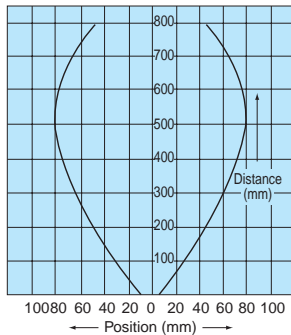

UM-T50DS

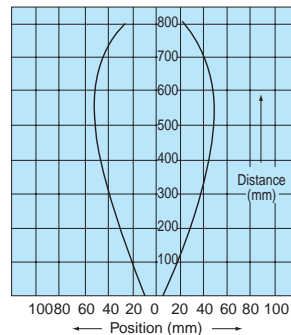

Activation area characteristics

UM-R3T·UM-R3TV

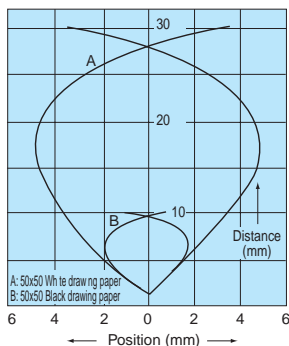

UM-R5T·UM-R5TV

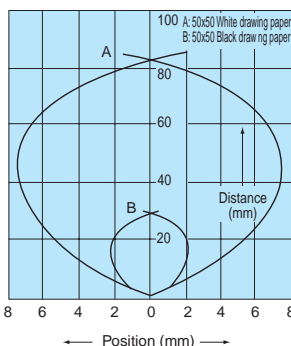

UM-Z3SV

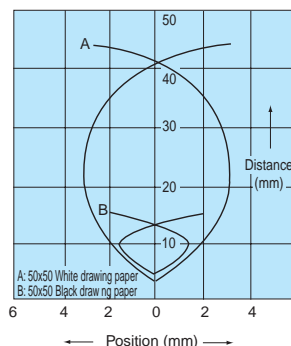

Distance-area characteristics

UM-T15DT·UM-T15DTV

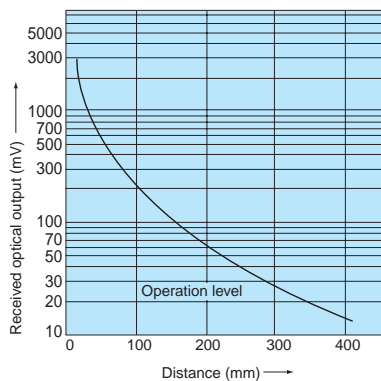

UM-T50DT·UM-T50DTV

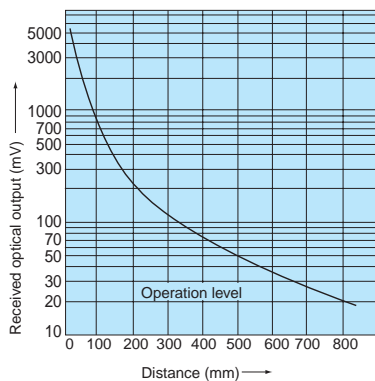

UM-T50DS

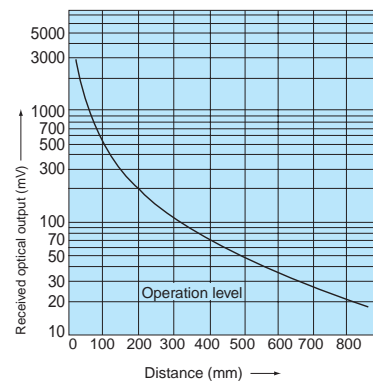

UM-R3T·UM-R3TV

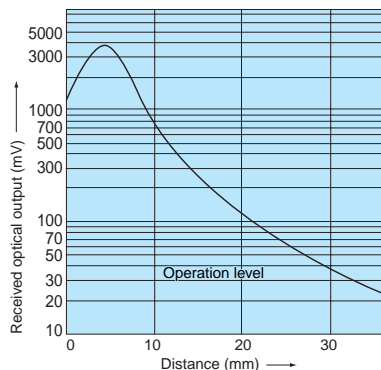

UM-R5T·UM-R5TV

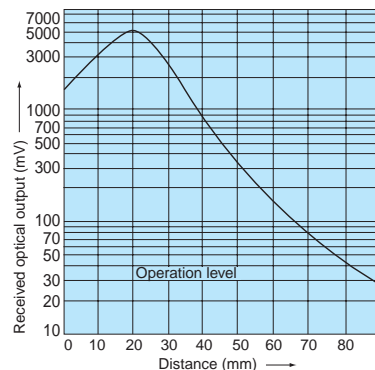

UM-Z3SV

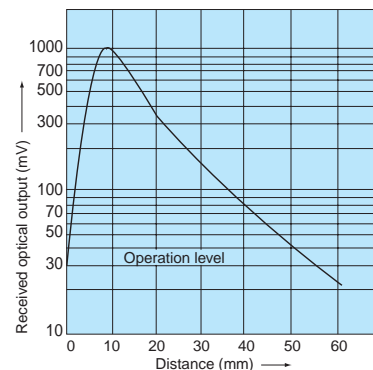

Dimensions (in mm)

UM-T15DT
UM-T15DTV(*1)

CAD Transmitter

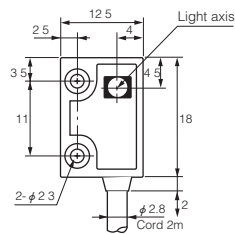

(The profile, which is the same as the receiver except that indicator is omitted.)

Receiver

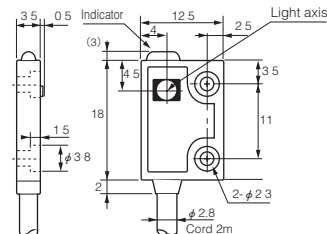

M2 x 10 mm screws, nuts, internal toothed washers provided.

UM-T50DT•UM-T100DT
UM-T50DTV(*1)

CAD Transmitter

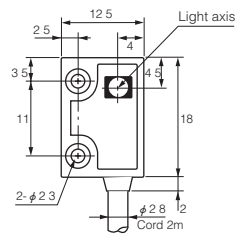

(The profile, which is the same as the receiver except that it has no indicator, is omitted.)

Receiver

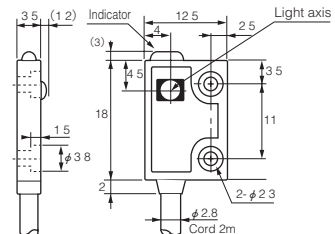

M2 x 10 mm screws, nuts, internal toothed washers provided.

UM-T50DS
UM-T100DS

CAD Transmitter

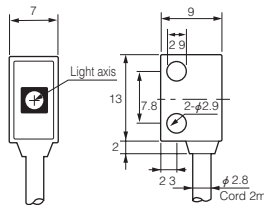

M2.6 x 12 mm screws, nuts, internal toothed washers provided.

Receiver

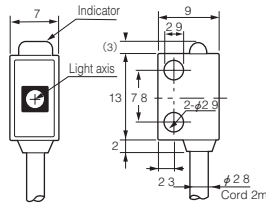

UM-R3T
UM-R3TV(*1)

CAD

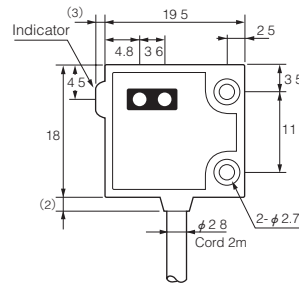

M2 x 10 mm screws, nuts, internal toothed washers provided.

UM-R5T
UM-R5TV(*1)

CAD

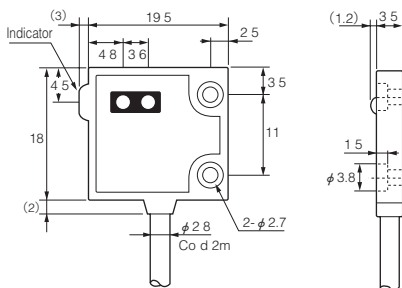

M2 x 10 mm screws, nuts, internal toothed washers provided.

(*1) Models identified by "V" at the end of the model number are equipped with a sensitivity adjustment volume. For through-beam type, the volume is provided in the receiver cord.

CAD

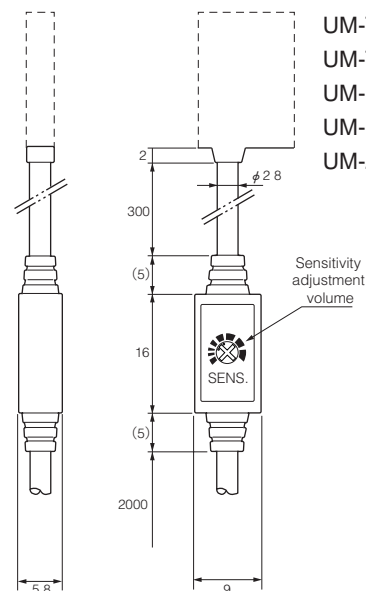

UM-Z3SV(*1)

CAD

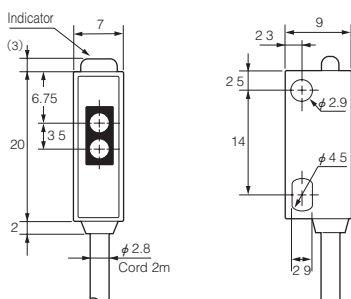

M2.6 x 12 mm screws, nuts, internal toothed washers provided.

• Directly screw onto the surface for mounting. The tightening torque should not exceed 0.3 N·m. Mounting brackets are available as optional parts.

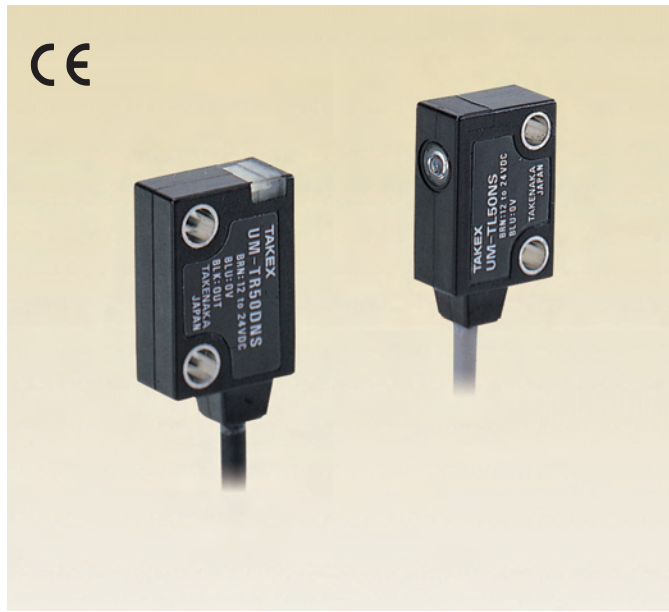

- Slim slide-on style sensor
- Basic function model for applications ranging from flush-mounting to small conveyor lines
- In-line sensitivity adjustment

<Sample application> detection of translucent objects

Sensitivity adjustment allows detection of objects even if they do not completely block light.

<Sample application> detection of small objects

Small object that blocks light axis but cannot be detected due to light going around it may be detected by adjusting sensitivity.

(Note) Be sure to test the operation before use.

Type

Detection method	Detecting distance	Model	In-line sensitivity adjustment volume	Operation mode	Output mode
 Through-beam type	500mm	UM-T50DNS	—	Dark-ON	NPN Open collector
		UM-T50DNSV	Provided		
		UM-T50NS	—	Light-ON	
		UM-T50NSV	Provided		

Input/Output Circuit and Connection

Model: UM-TR50DNS
UM-TR50NS

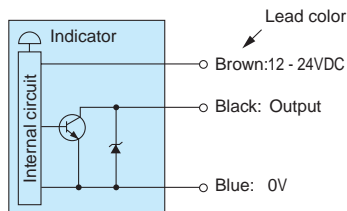

Model: UM-TR50DNSV
UM-TR50NSV
With in-line sensitivity adjustment volume

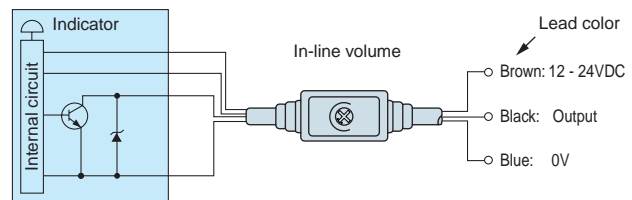

The transmitter of the through-beam type is provided with power supply lines (brown: 12~24 VDC; blue: 0 V) only.

Rating/Performance/Specification

Type		UM-T50DNS	UM-T50DNSV	UM-T50NS	UM-T50NSV
Detection method		Through-beam type			
Detecting distance		500mm			
Detection object		φ 3mm (Min.) Opaque			
Power supply		12 - 24V DC ± 10% / Ripple 10% max.			
Current consumption	Transmitter	14mA max.			
	Receiver	14mA max.	22mA max.	14mA max.	22mA max.
Output mode		NPN open collector Rating: sink current 100 mA (30 VDC) max.			
Operation mode		Dark-ON		Light-ON	
Response time		0.5ms max.			
Operating angle		13°			
Hysteresis		—————			
Light source (light wavelength)		Red LED (660nm)			
Indicator		Operation indicator (red LED)		Stability indicator (green LED)	
Volume		—————	In-line sensitivity adjustment *	—————	In-line sensitivity adjustment *
Material	Case	Polybutylene terephthalate			
	Lens	Polyarylate			
Connection		Permanently attached cord (outer dimension: dia. 2.8) Transmitter 0.15 sq. 2 core 2 m length (gray) Receiver 0.15 sq. 3 core 2 m length (black)			
Mass	Transmitter	Approx. 30g			
	Receiver	Approx. 35g	Approx. 40g	Approx. 35g	Approx. 40g
Notes		* Length of cord between sensor and in-line sensitivity adjustment: 300 mm (fixed)			
Ambient light		3,000 lx max.			
Ambient temperature		-25 - +55 -C (non-freezing)			
Ambient humidity		35 - 85%RH (non-condensing)			
Protective structure		IP64			
Vibration		10 - 55 Hz / 1.5 mm amplitude / 2 hours each in 3 direction			

Characteristics (Typical Example)

Directional characteristics

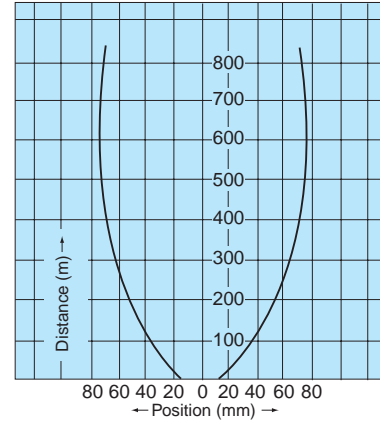

Distance-area characteristics

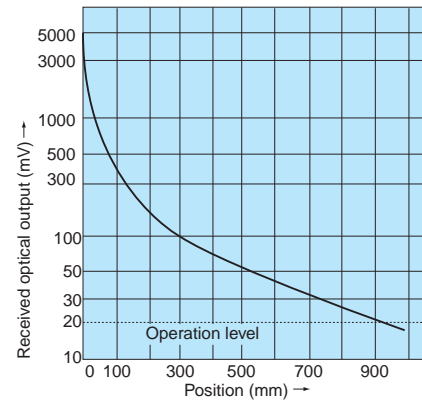

Dimensions (in mm)

Transmitter

CAD

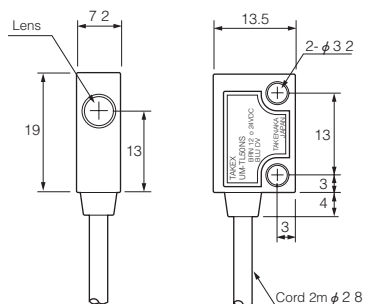

- No mounting bracket is provided.
- For mounting, use the screws provided.
The tightening torque not exceed 0.3 N·m.

(M3 x 15 mm screws, nuts, two 3-piece sems screws provided)

Receiver

CAD

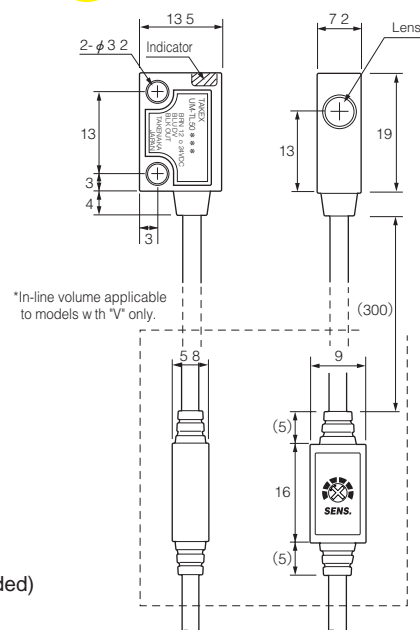

Mini-G series

Embedded Amplifier Photo Sensors



- Ultra small size ideal for embedded use
- IP 67 water resistance for wet environments
- Stability output is provided
- High-speed response of 0.35 ms
 - High-powered light penetrating business cards: GT1SN, GT1N
 - Long detecting distance of 10 m: GT3RSN
 - High-performance detection at shorter distance: GS5SN, GS5N
 - Less affected by background: limited reflection type
 - Easy light axis alignment: red LED type

Type

Detection method	Detecting distance	Model		Operation mode	Output mode
		Side-on type	Head-on type		
⬆ Through-beam type	1m	GT1SN	_____	Light-ON/ Dark-ON selectable (with switch)	NPN Open collector
	7m	_____	GT1N		
	10m	_____	GT3N		
	7m	GT3RSN	_____		
⬆ Reflector type	0.01~2m	GSM2RSN	_____		
		GS5SN	_____		
⬆ Diffuse-reflective type	70mm	_____	GS5N		
	400mm	GS20RSN	_____		
	300mm	_____	GS20RN		
	300mm	GS20SN	_____		
⬆ Limited reflection type	200mm	_____	GS20N		
	1~40mm	GSZ3SN	_____		
	3~30mm	GSZ3RSN			

Optional Parts

Type	Model	Pinhole diameter	Applicable model and detecting distance (attached to both transmitter and receiver)	
Pinhole plate (SUS)	GP1	φ 1mm	GT3RSN400mm GT7SN300mm	Two plates required for attaching to both transmitter and receiver.
	GP2	φ 2mm	GT3RSN1m GT7SN1m	
	GP3	φ 3mm	GT3RSN3m GT7SN2.5m	
	GP5-1	5 x 1mm	GT3RSN2m GT7SN1.7m	

(Models GT1N is provided with stick-on pinhole sheets.)

• Attachment of pinhole plate

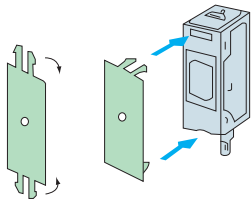

Manually bend the top and bottom parts at the base and insert the bent parts into the sensor slits.

Protective cover	G-MSB1	Applicable to side-on type	Rigid SUS covers for protecting sensors and reflectors from impact, etc. See p. 211 for details.
	G-MTB1		
	G-K7B	Applicable to K-7 and K-71 reflectors	

• Applicable power supply unit

PS series
High capacity of 200 mA at 12 VDC

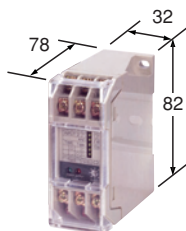

(General-purpose type) PS3N
PS3N-SR
(Multifunctional type) PS3F
PS3F-SR

Mini-G

Rating/Performance/Specification

Type	Side-on	GT1SN	—	GT3RSN	GT7SN	GSM2RSN	GS5SN	GS20RSN	GS20SN	GSZ3SN	GSZ3RSN
	Head-on	GT1N	GT3N	—	—	—	GS5N	GS20RN	GS20N	—	—
Detection method	Through-beam type					Reflective type	Diffuse-reflective type			Limited reflection type	
Detecting distance	1m	7m	10m	7m	0.01~2m*	70mm	400mm (GS20RSN) 300mm (GS20RN)	300mm (GS20SN) 200mm (GS20N)	1~40mm	3~30mm	
Detection object	φ 6mm (Min.) Opaque					—	50 x 50 mm white drawing paper	100 x 100 mm white drawing paper		—	
Power supply	24V DC ±10% / Ripple 10% max.										
Current consumption	Transmitter: 23mA max. Receiver: 18 mA max.		Transmitter: 20mA max. Receiver: 18 mA max.		Transmitter: 23mA max. Receiver: 18 mA max.		20mA max.	25mA max.	20mA max.	22mA max.	20mA max.
Output mode	Control output	NPN open collector output Rating: sink current 100 mA (30 VDC) max. (PNP output type also available)									
	Stability output	NPN open collector output Rating: sink current 50 mA (30 VDC) max. (PNP output type does not have stability output)									
Operation mode	Light-ON/Dark-ON selectable (with switch)										
Response time	0.35ms max.										
Hysteresis	—						10% max.				
Operating angle	30° (at receiver)	10° (at receiver)				30° (at reflector)	—				
Light source (light wavelength)	Infrared LED (880nm)		Red LED (700nm)	Infrared LED (880nm)	Red LED (700nm)	Red LED (900nm)	Red LED (700nm)	Red LED (900nm)	Red LED (900nm)	Red LED (900nm)	Red LED (700nm)
Indicator	Transmitter: Power indicator (red LED) Receiver: Operation indicator (red LED) Stability indicator (green LED)					Operation indicator (red LED) Stability indicator (green LED)					
Volume	SENS: Sensitivity adjustment (on receiver for through-beam type)										
Switch	Light-ON/Dark-ON selector switch provided L.ON side---Light-ON / D.ON side--- Dark-ON On the bottom for head-on type, on the back for side-on type										
Short circuit protection	Provided (for control output only)										
Material	Case	Polyarylate									
	Lens	Polycarbonate	Polyarylate				Polycarbonate	Polyarylate		Polycarbonate	Acrylic
Connection	Permanently attached cord (outer dimension: dia. 3) (Transmitter) 0.15 sq. 2 core 2 m length (gray) (Receiver) 0.15 sq. 4 core 2 m length(black)					Permanently attached cord (outer dimension: dia. 3) 0.15 sq. 4 core 2 m length(black)					
Mass	About 50 g (transmitter/receiver)					Approx. 50g					
Notes	(Pair of) pinhole sheets provided (only GT1N)	—			Pinhole plates optional		*When used with K-71 reflector provided				
	Mounting bracket, operation manual provided										

Environmental Specification

Ambient light	5,000 lx max.
Ambient temperature	-25 - +55 -C (non-freezing)
Ambient humidity	35~85%RH (non-condensing)
Protective structure	IP67
Vibration	10~55 Hz / 1.5 mm amplitude / 2 hours each in 3 direction
Shock	500 m/s2 / 3 times each in 3 directions
Dielectric strength	1,000 VAC for 1 minute
Insulation resistance	500 VDC, 20 MΩ or higher

* Detecting distances for different reflectors

The detecting distance depends on the reflector used.

Reflector model	K-71	K-7	S-25
Detecting distance	0.01 - 2m	0.01 - 3m	70 - 400mm

Input/Output Circuit and Connection

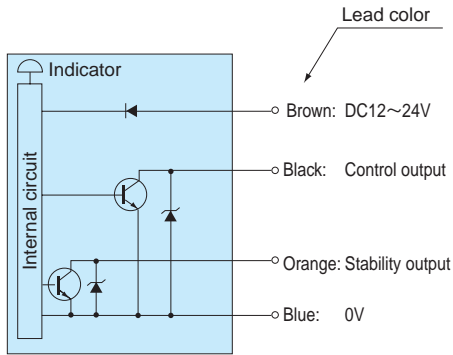

- The transmitter is provided with power supply lines (brown: 12 - 24 VDC; blue: 0 V) only.
- The output transistor turns off when load short circuit or overload occurs. Check the load and turn the power back on.

Characteristics (Typical Example)

• Directional characteristics

GT1SN·GT1N

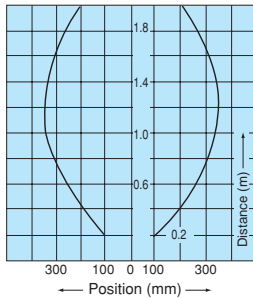

GT3N·GT7SN

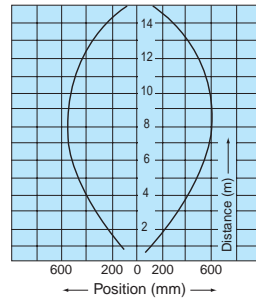

GT3RSN

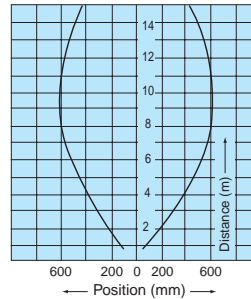

GSM2RSN (K-71)

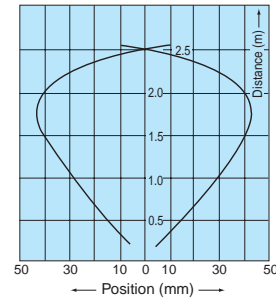

• Operating angle characteristics

GT1SN·GT1N

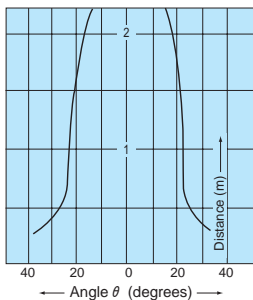

GT3N·GT7SN

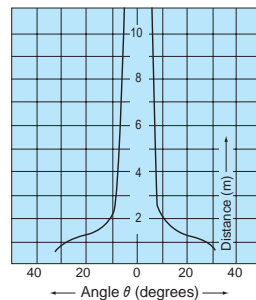

GT3RSN

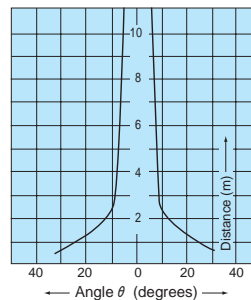

GSM2RSN (K-71)

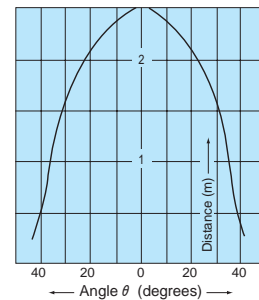

• Temperature characteristics

Reflective type

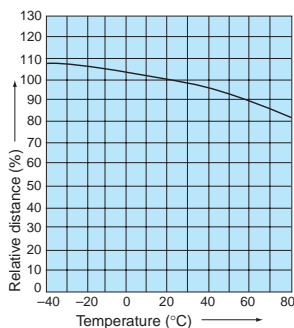

Through-beam type

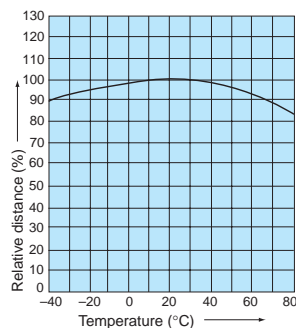

Mini-G

• Activation area characteristics

GS5SN

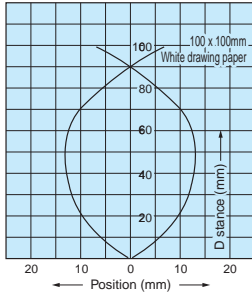

GS5N

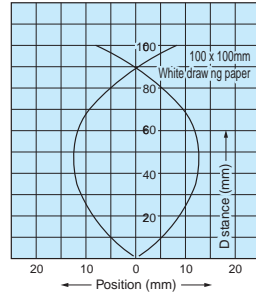

GS20RSN

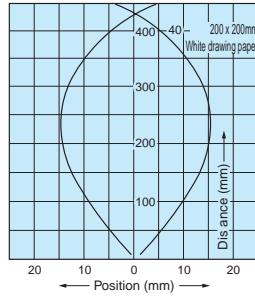

GS20RN

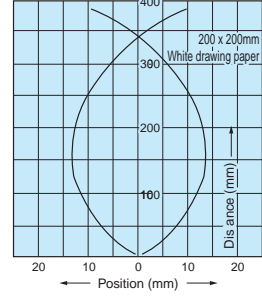

GS20N

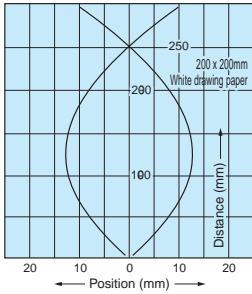

GS20SN

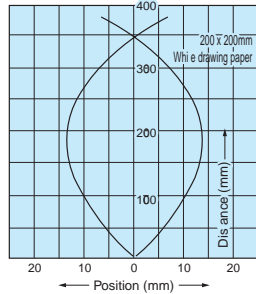

GSZ3SN

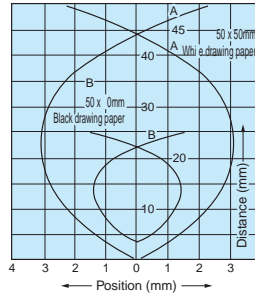

GSZ3RSN

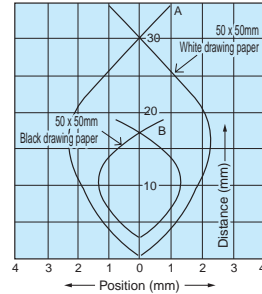

• Distance-area characteristics

GS5SN

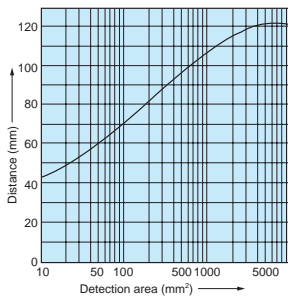

GS5N

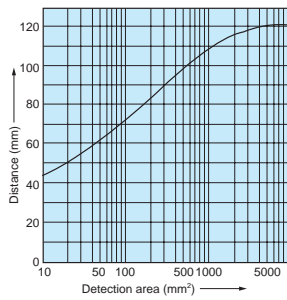

GS20RN

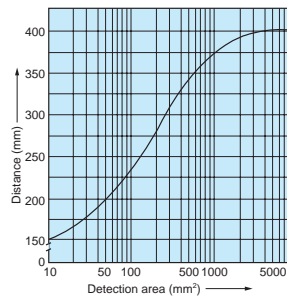

GS20RSN

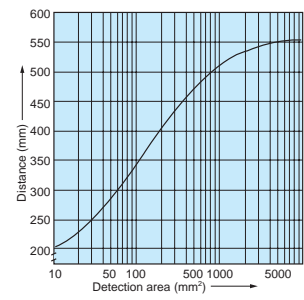

GS20N

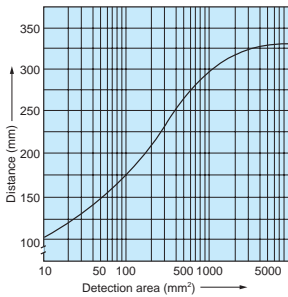

GS20SN

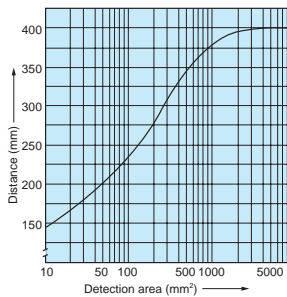

Dimensions (in mm; tightening torque for mounting screws: 0.6 N·m max.)

Side-on type

CAD

GT1SN
GT3RSN
GT7SN
GS5SN
GSM2RSN
GS20RSN
GS20SN
GSZ3SN
GSZ3RSN

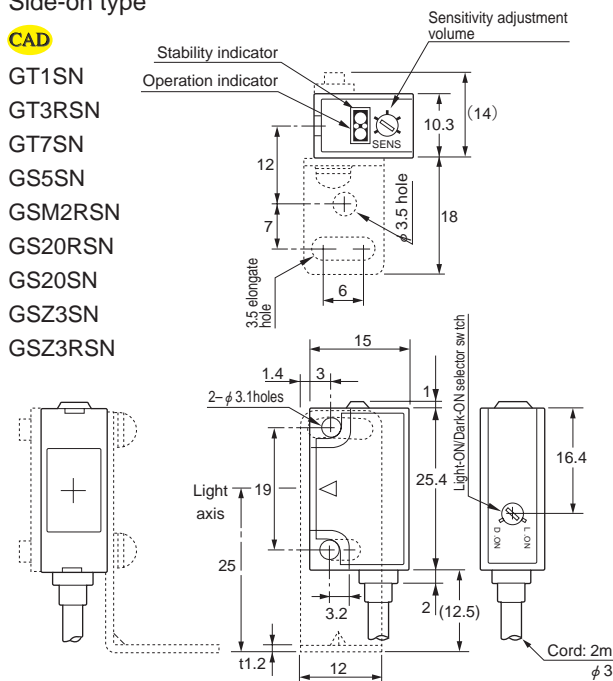

*The transmitter side of the through-beam type is provided with power indication only.

Head-on type

CAD

GT1N
GT3N
GS5N
GS20N
GS20RN

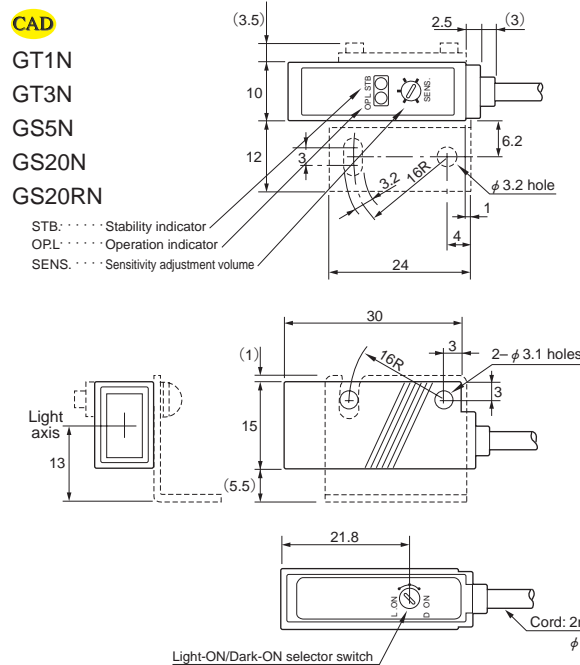

*The transmitter side of the through-beam type is provided with power indication only.

Reflector

CAD

K71

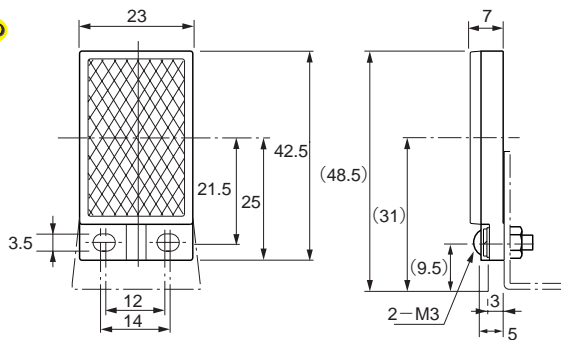

(Applicable to polarization reflector type
Effective reflecting surface: 19 x 32 mm
Mounting: mounting bracket provided, secured with M3 screws (alternatively adhesive may be used)

Stability output

The stability output can be used to check for reduction of the light intensity level along with any change in the operating environment or operation over time or to perform initial check of the operation. When two consecutive detections have occurred with the intensity of light detected exceeding the operation level but not reaching 120% of the level (range allowing stable operation), the stability signal is output when the control output is deactivated. (This output is not available with the PNP output types of the Mini-G Series.)

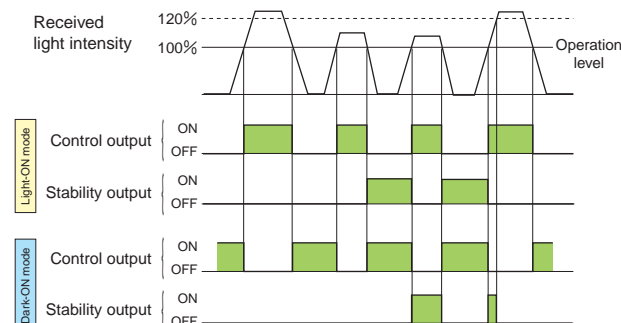

Indicators

- The operation indicator (red LED) and stability indicator (green LED) show the levels of light intensity as described in the figure below.
- After aligning the optical axis and adjusting the sensitivity, use a detection object to block and unblock the light beam several times to make sure that the sensitivity level is in a range that allows stable activation and deactivation.
- Setting the sensitivity in a range allowing stable operation achieves higher reliability against changes in the operating environment generated after the sensitivity is set.

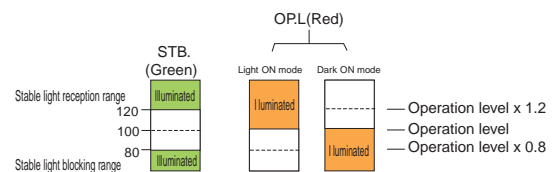

The orange LED (OPL) is the operation indicator.

In the L.ON (Light-ON) mode, the indicator is illuminated when a certain amount of light is detected.

In the D.ON (Dark-ON) mode, the indicator is illuminated when a certain amount of light is not detected.

Sensitivity adjustment (for Light-ON mode)

(Adjustment for Light-ON mode)

- When any light-reflecting object is in the background
- (1) Place the object to be detected in a given position, turn up the sensitivity adjustment volume (SENS.) gradually and find the point at which the operation indicator (red LED) is illuminated (Point A).
- (2) Remove the object, turn down the sensitivity adjustment volume gradually from MAX. and find the point at which the operation indicator (red LED) goes out (Point B). (If the operation indicator is not illuminated even at Max., MAX. is regarded as Point B.)
- (3) Set the volume at midway between Points A and B.

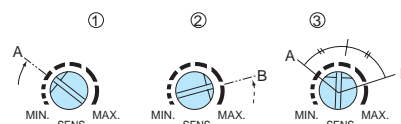

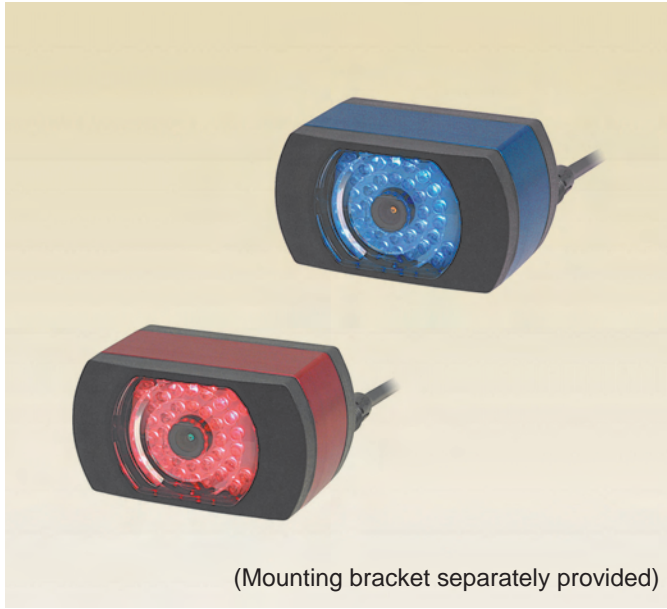

- World's first 2D sensing utilizing the BGS method
- Size (area/presence), number and position of object detected with compound eye utilizing a pulsating light and 3072 points of reference
- Reflective sensor using a new system integrating transmitter / receiver amplifier and monitor function in one unit
- Anti-Interference feature

Type

Detection method	Detecting distance	Model	Operation mode	Output mode
Compound eye detection	80~200mm	VS-S20R	Judgment	NPN open collector
		VS-S20B		
	100~500mm	VS-S50RNF		
		VS-S50BNF		

Optional Parts

Type	Model	Description
Special mounting bracket	DX-B1	H-shaped (for face mounting)
	DX-B2	L-shaped (for side mounting)

BGS method

Unique pulsating light emission employed for less influence of background and increased stability against disturbing light.

MSR feature

Provided with a feature to minimize the effect of mirror surface (VS-S20R, VS-S20B) for accurate object detection

Long distance/wide field of view

Wide detection field with a detecting area of 250 x 180 mm at a distance of 500 mm (VS-S50RNF, VS-S50BNF; MSR feature not provided).

Anti-Interference feature

Anti-interference detection feature in master/slave mode is available for use of two sensors installed in parallel or face-to-face.

Rating/Performance/Specification

Type	VS-S20R / VS-S20B*2	VS-S50RNF / VS-S50BNF*2
Detecting distance	80 - 200mm	100 - 500mm
Detecting area (field of view)	100 (H) x 75 (V) mm at 200 mm	250 (H) x 180 (V) mm at 500 mm
Detecting resolution	Total number of points in detecting area (field of view) 3072 point = 64 (H) x 48 (V)	
Minimum detectable object	φ 1 mm (at detecting distance of 200 mm, 2 x zoom)	
Power supply	24V DC ±10% / Ripple 10% max.	
Current consumption	300mA max.	
Output	2 NPN open collector 2 outputs	
	Sink current 50 mA (30 VDC) max. Residual voltage: 2 V max.	
Input	2 inputs	
	Rating: 5mA 24VDC	
Response time	25 ms max. in Continuous mode and at shutter speed 240	
Mirror surface rejection	Provided	Not provided
Light source (wavelength)	Red LED (639nm) Blue LED (466nm) *2	
Light-sensitive element	2D photo diode array	
Indicator	LCD display	
Operating switch	3 pushbutton switches for UP, DOWN, ENTER	
Material	Body: aluminum / Lens: acrylic / Front/rear panel: ABS	
Connection	6-pin waterproof plastic connector connection	
Mass	Approx. 250g	
Accessory	Cord with connector *1, operation manual	

*1: 0.2 mm2 x 6 / 2 m (outer diameter: 5 mm)

*2: Blue light source

Environmental Specification

Ambient light	1,000 lx max. (on light receiving surface)
Ambient temperature	-10 - +45 -C (non-freezing)
Ambient humidity	35 - 85%RH (non-condensing)
Protective structure	IP65
Vibration	10 - 55 Hz / 1.5 mm amplitude / 2 hours each in 3 direction
Shock	500 m/s ² / 3 times each in 3 directions
Dielectric strength	1,000 VAC 50/60Hz for 1 minute
Insulation resistance	500 VDC, 20 MΩ or higher

Input/Output Circuit and Sample Connection (in Continuous mode)

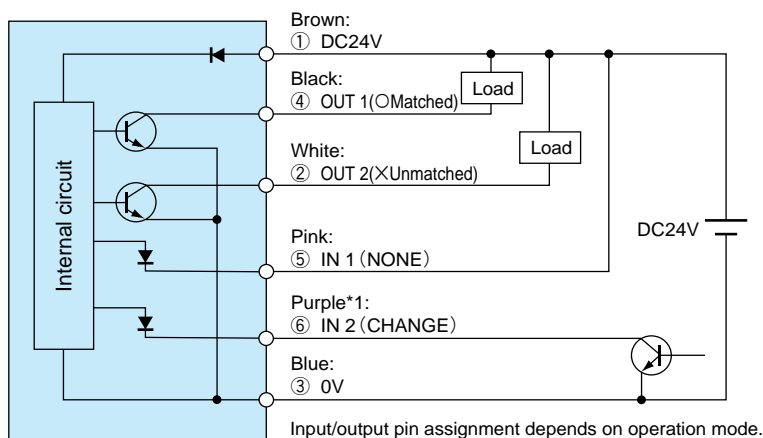

*1 Connect unused purple line (6) IN2 (CHANGE) to 24 VDC.

Sample Applications

- Checking of quantity in field of view

Field examined to check for any missing work.

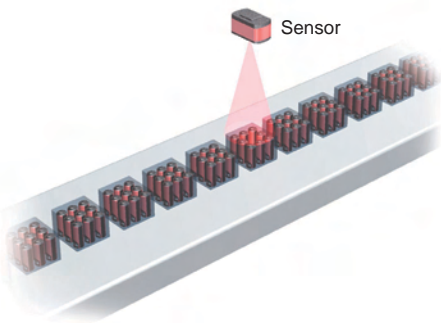

- Work area judgment

Field examined to check for nonstandard size.

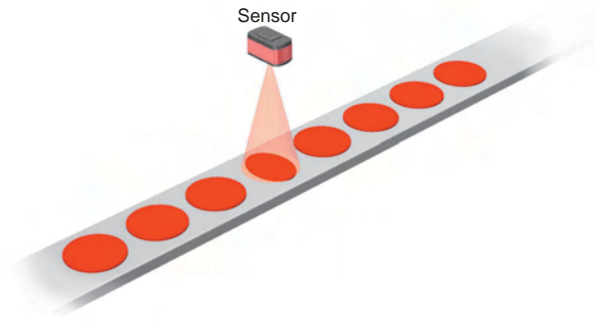

- Detection of label at specified position

Presence of label at specified position checked by XY coordinate teaching.

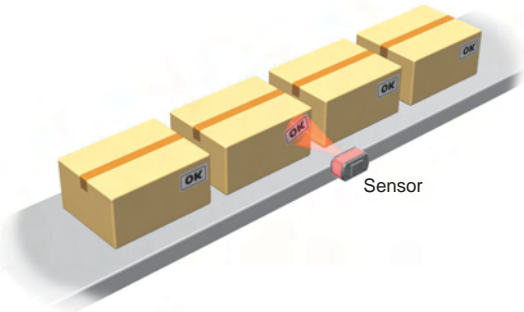

- Detection of parts in containers

Presence of measuring cups in containers checked.

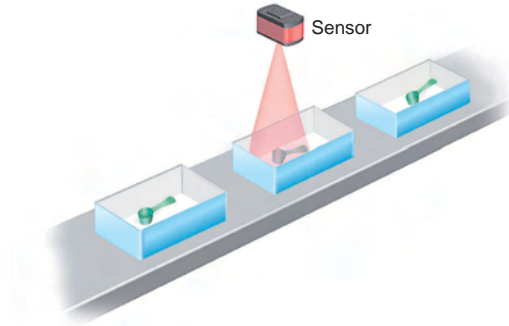

- Detection of hole at specified position

Presence of bored hole at specified position checked by XY coordinate teaching

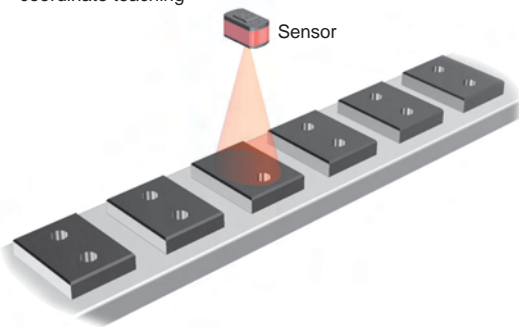

- Checking for angular displacement

Angular displacement of parts, etc. arranged in parallel checked by main axis angle detection feature.

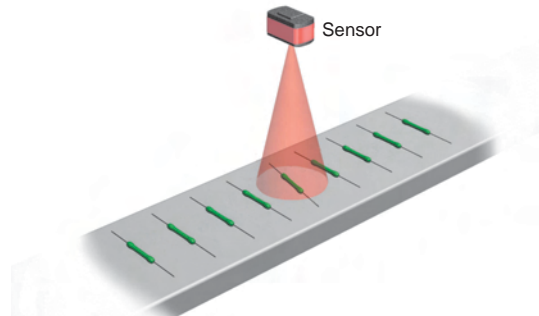

- Checking of position in detecting area

Position of work checked during picking by robot.

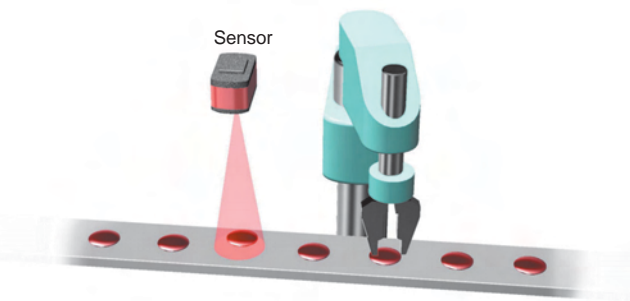

- Detection of presence in detecting area

Presence of print by inkjet printer checked.

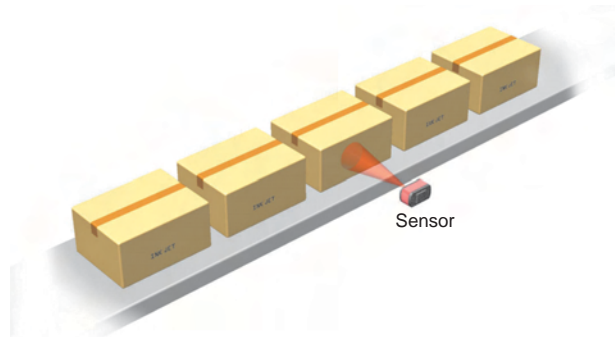

Appearance and Part Names

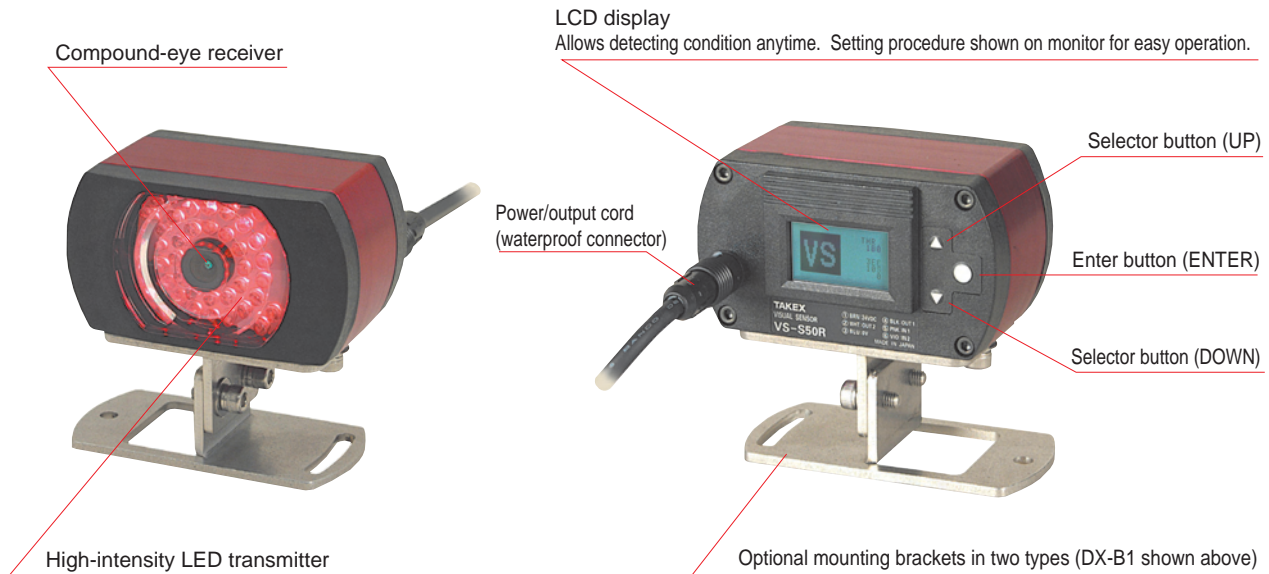

Detection/Judgment Feature

Detection of size (area/presence)

Applications

- Detection of nonstandard shape, etc.
- Checking of presence of print, label, etc.

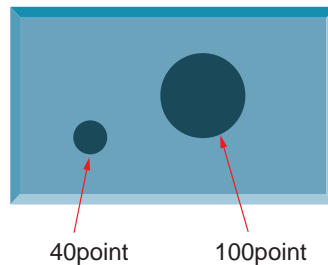

Two or more (up to 100) objects in the field can be individually detected to determine size, which allows the detection of a particular object alone by setting the upper and lower limits of the size (area). Presence can also be checked.

Determination of count

Applications

- Checking of package for smaller number of objects than specified
- Checking of connector lead count

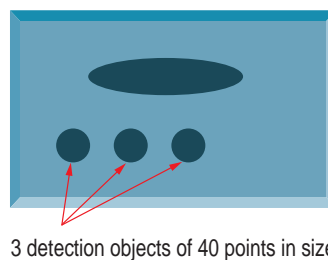

Two or more (up to 100) objects in the field can be individually detected for size determination, this provides determination of the number of detection objects of a given size as:

- Larger than the setting,
- Equal to the setting, or
- Smaller than the setting.

Checking of position

Applications

- Checking for displaced stickers
- Checking for wrong type mixed in

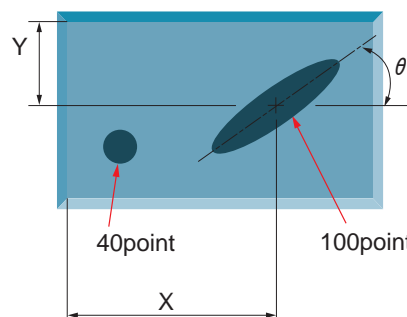

Two or more (up to 100) objects in the field can be individually detected for size determination, which therefore allows the user to determine the position of one detected object of a given size by:

- X-coordinate of the center of gravity,
- Y-coordinate of the center of gravity, and
- Inclination (θ).

Judgment Output Timing Chart

Operation mode	Input/output setting	Operation timing chart
<p>Continuous/Self synchronization mode</p>	<p>OUT1 : OK</p> <p>OUT2 : NG</p>	
<p>External synchronization mode</p> <p>If a TRIGGER signal is input while the READY output is active, a RUN is started.</p> <p>The READY output is deactivated during a RUN.</p> <p>The output mode factory setting is OK, which means that the signal is output when the detection is judged OK.</p>	<p>IN1 : TRIGGER</p> <p>OUT1 : OK/NG</p> <p>OUT2 : READY</p>	
<p>External synchronization mode</p> <p>When NG is selected as the output mode, the signal is output when the detection is judged NG.</p>	<p>IN1 : TRIGGER</p> <p>OUT1 : OK/NG</p> <p>OUT2 : READY</p>	

Dimensions (in mm)

Body

CAD

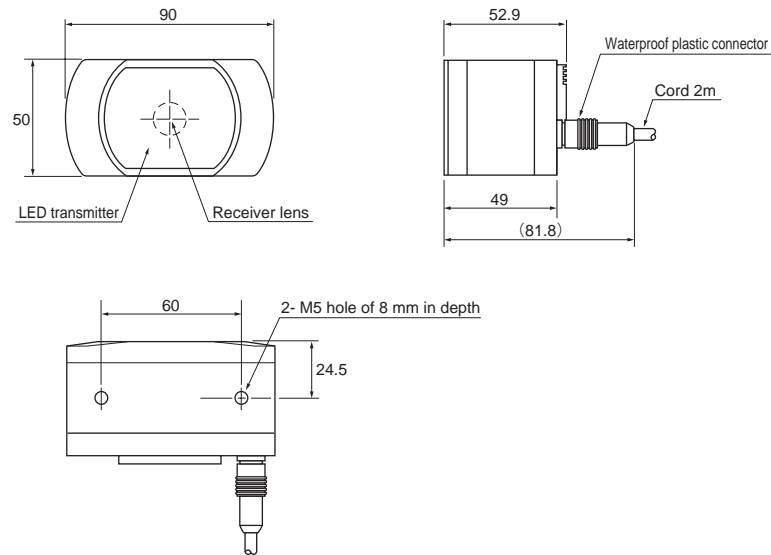

With mounting bracket model DX-B1 attached
Mounting brackets are optional.

CAD

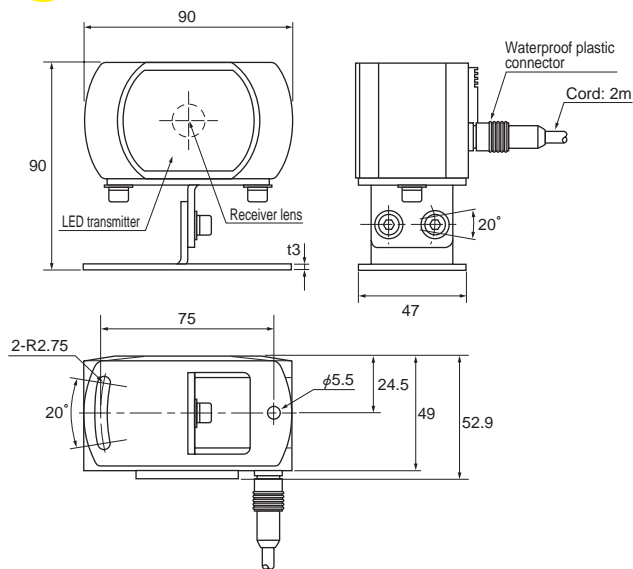

With mounting bracket model DX-B2 attached
Mounting brackets are optional.

CAD

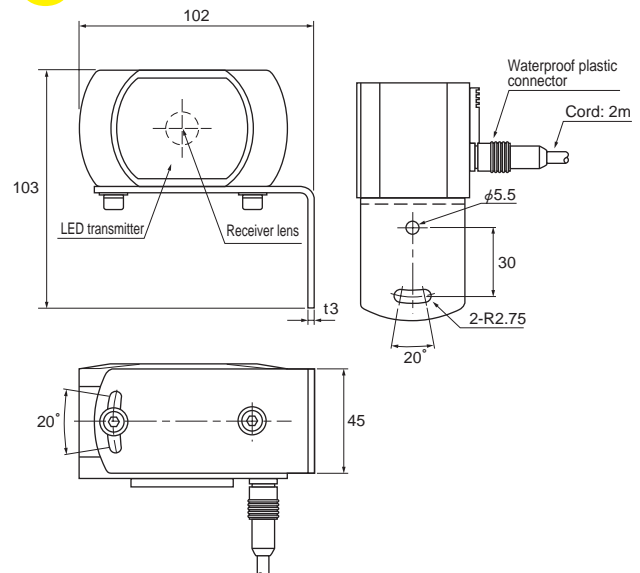



- Simple operation of just pressing button
One large button alone handling sensitivity adjustment and Light-ON/Dark-ON switching
- Sensitivity adjustment not requiring placing of work
Simple sensitivity adjustment without placement of work for detection in narrow spaces or of falling objects that cannot be easily stopped
- Equipped with inverter light suppression circuit
Faulty operation under inverter fluorescent lamps prevented
- IP 67 water resistance allows washing
Reliable use even in sites subject to water or high moisture

Type

Detection method	Detecting distance	Model		Operation mode	Output mode
		NPN type	PNP type		
Polarization reflector type	0.1 - 3m	GA-M3R	GA-M3RPN	Light-ON/ Dark-ON (by teaching)	Open collector
Diffuse-reflective type	500mm	GA-S05R	GA-S05RPN		

Optional Parts

Product name	Model	Description
Polarization reflector	K-7	Dimensions: 60 x 40 mm / Detecting distance: 0.1 - 3 m
	K-71	Dimensions: 35 x 23 mm / Detecting distance: 0.1 - 1.8 m
Mounting bracket	GA-B1	Vertical mounting bracket
	GA-B2	Horizontal mounting bracket
Protective cover	G-MSB1	Rigid protective cover doubling as mounting bracket. See p. 211.
	G-MTB1	
	G-K7B	

Polarization reflectors and mounting brackets do not come with sensors. Select and purchase appropriate models according to the detecting and mounting conditions.

Sample Applications

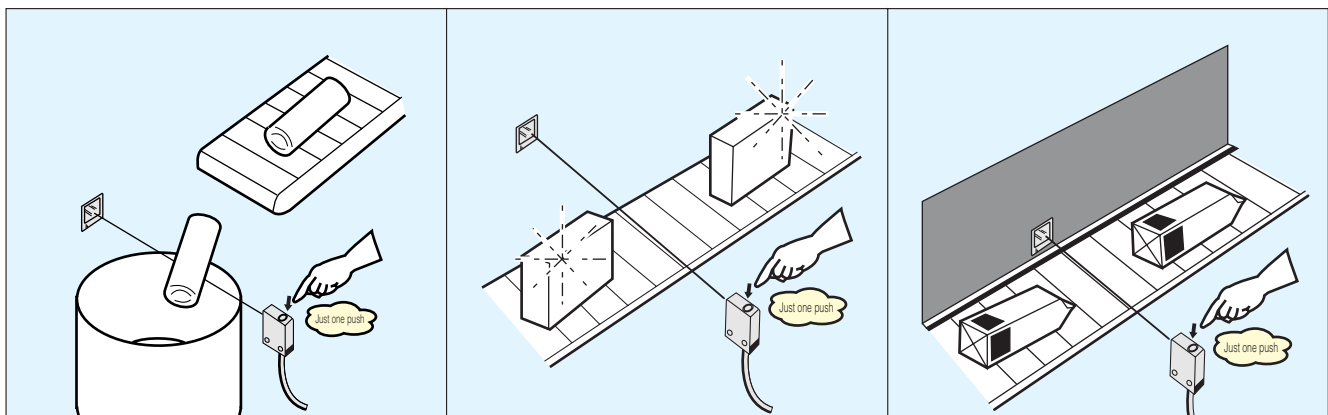

Rating/Performance/Specification

Type	NPN type	GA-M3R	GA-S05R
	PNP type	GA-M3RPN	GA-S05RPN
Detection method		Polarization reflector type	Diffuse-reflective type
Detecting distance		0.1 - 3 m (With K-7 reflector)	500mm (Standard detection object: 200 x 200 mm white drawing paper)
Power supply		12-24V DC $\pm 10\%$ / Ripple 10% max.	
Current consumption	NPN type	30mA max.	
	PNP type	30mA max.	
Output mode	Control output	NPN type	Open collector output Rating: Sink current 100 mA (30 VDC) max. / Residual voltage: 1 V or less
		PNP type	Open collector output Rating: source current 100 mA (30 VDC) max. / Residual voltage: 1 V or less *
	Stability output	NPN type	Open collector output Rating: Sink current 50 mA (30 VDC) max. / Residual voltage: 1 V or less *
		PNP type	Open collector output Rating: source current 50 mA (30 VDC) max. / Residual voltage: 1 V or less *
Operation mode		Light-ON/Dark-ON selectable	
Response time		1ms max.	
Light source		Red LED (700nm)	Red LED (644nm)
Indicator		Operation indicator (orange LED) Stability indicator (green LED)	
Setting button		For sensitivity adjustment and Light-ON/Dark-ON switching	
Short circuit protection		Provided	
Material		Case: polyarylate Lens: acrylic	Case: polycarbonate Lens: acrylic
Connection		Permanently attached cord (outer dimension: dia. 4.2mm) 0.2 sq. 4 core 2 m length	
Mass		Body: about 60 g	
Accessory		Operation manual, explanation sticker (Note: reflector and mounting bracket separately available)	

* The residual voltage of GA-M3R (PN) is 2 V max.

Environmental Specification

Ambient light	5,000 lx max.
Ambient temperature	-25 - +55 -C (non-freezing)
Ambient humidity	35~85%RH (non-condensing)
Protective structure	IP67
Vibration	10 - 55 Hz / 1.5 mm amplitude / 2 hours each in 3 direction
Shock	500 m/s ² / 3 times each in 3 directions
Dielectric strength	1,000 VAC for 1 minute
Insulation resistance	500 VDC, 20 M Ω or higher

Indicators

The figure below shows the illumination of operation and stability indicators for different received light intensity levels. Set the sensitivity in such a way that the sensor operates in a sensitivity range that allows stable activation.

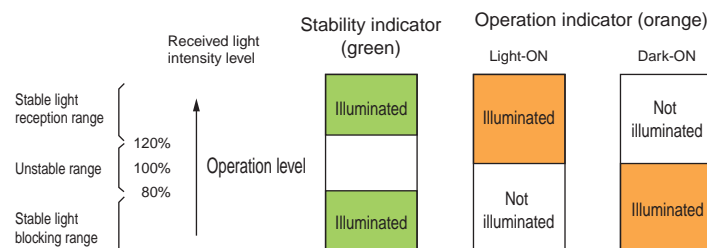

Stability output

When seven consecutive detections have occurred with the intensity of light detected not reaching the range allowing stable operation, the stability signal is output.

Input/Output Circuit and Connection

NPN output
GA-M3R
GA-S05R

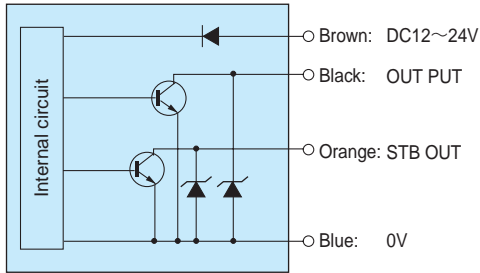

PNP output
GA-M3RPN
GA-S05RPN

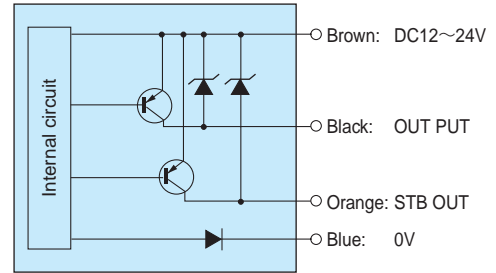

Characteristics (Typical Example)

Directional characteristics

GA-M3R
GA-M3RPN

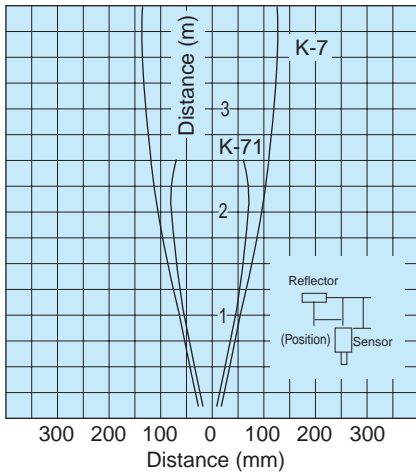

Activation area characteristics

GA-S05R
GA-S05RPN

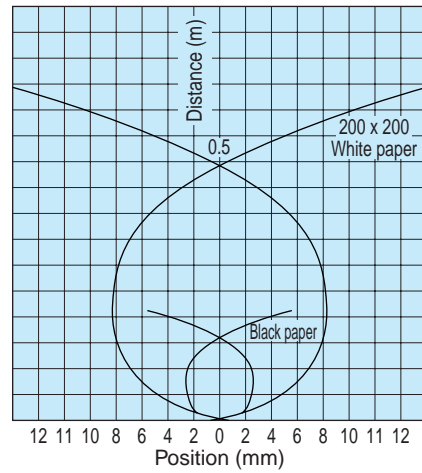

Operating angle characteristics

GA-M3R
GA-M3RPN

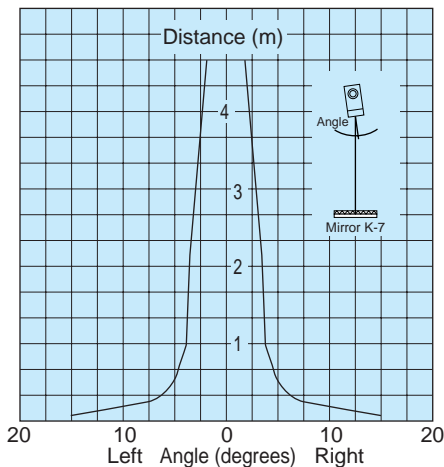

Distance-output characteristics

GA-S05R
GA-S05RPN

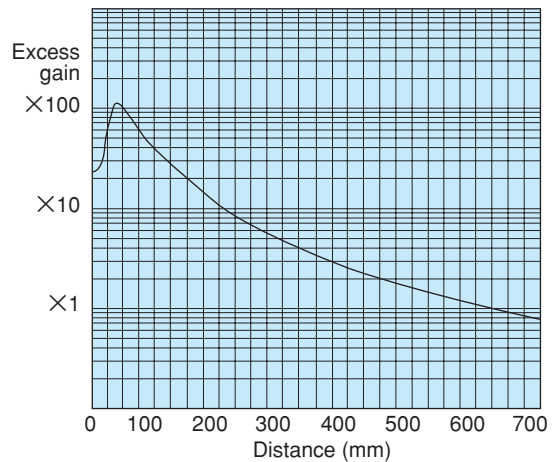

Dimensions (in mm)

Sensor body
GA-M3R
GA-M3RPN
GA-S05R
GA-S05RPN

CAD

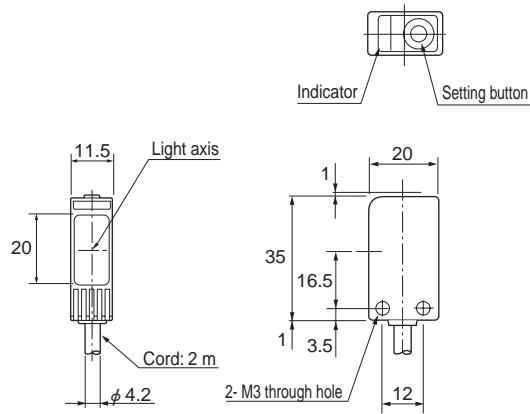

Polarization reflector
K-7

CAD

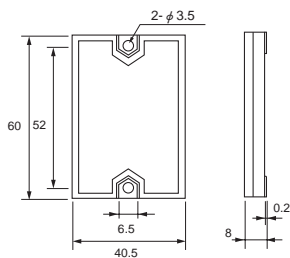

(Applicable to polarization reflector type
Effective reflecting surface: 56 x 36 mm
Mounting: secured with M3 screws
(alternatively adhesive may be used)
Protective structure: IP 67)

Polarization reflector
K-71

CAD

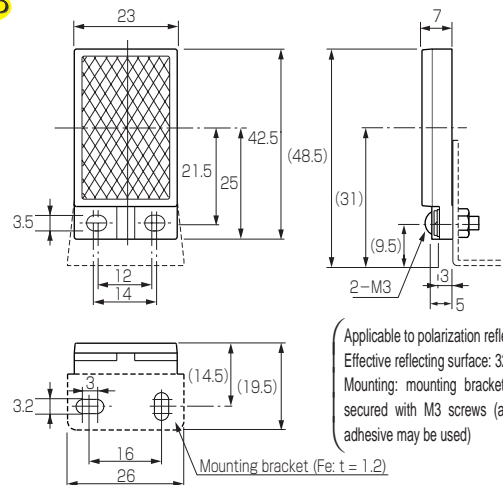

(Applicable to polarization reflector type
Effective reflecting surface: 32 x 19 mm
Mounting: mounting bracket provided,
secured with M3 screws (alternatively
adhesive may be used)

With separately available mounting bracket (GA-B1) attached

CAD

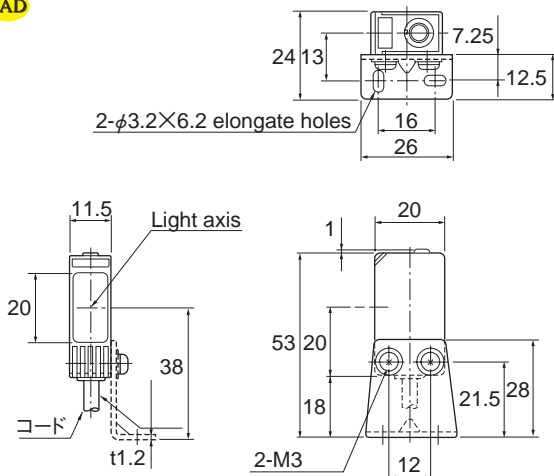

With separately available mounting bracket (GA-B2) attached

CAD

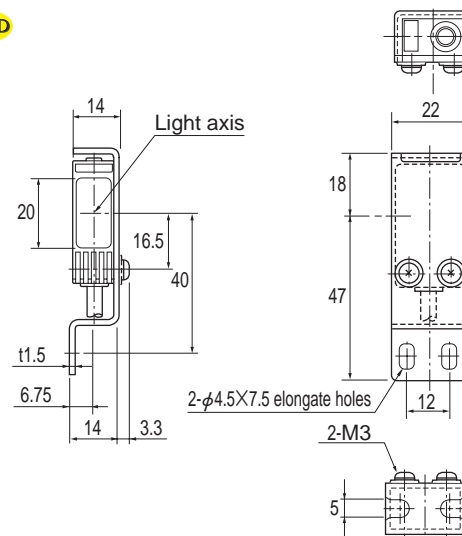

GA-M3R GA-M3RPN

For Correct Use

Be sure to follow the instructions in the operation manual provided for correct use of the product.

Part names

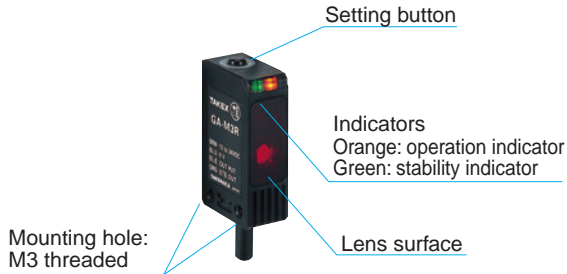

This sensor only has one setting button and no sensitivity adjustment volume or selector switch. Light-ON/Dark-ON switching and sensitivity setting are handled with the setting button alone. Enter the sensitivity setting mode or Light-ON/Dark-ON switching mode by pressing and holding down the button for a period of time as specified below:

- Hold down setting button for 2 - 4 seconds → Sensitivity setting mode
- Hold down setting button for 5 seconds or longer → Light-ON/Dark-ON switching mode

Switching between Light-ON/Dark-ON mode

The factory setting is Dark-ON mode. Be sure to check and set either the Light-ON or Dark-ON mode before setting the sensitivity. Enter the Light-ON/Dark-ON switching mode by pressing the setting button for 5 seconds or longer. While the button is operated, the state of the output before starting the operation of the button is maintained.

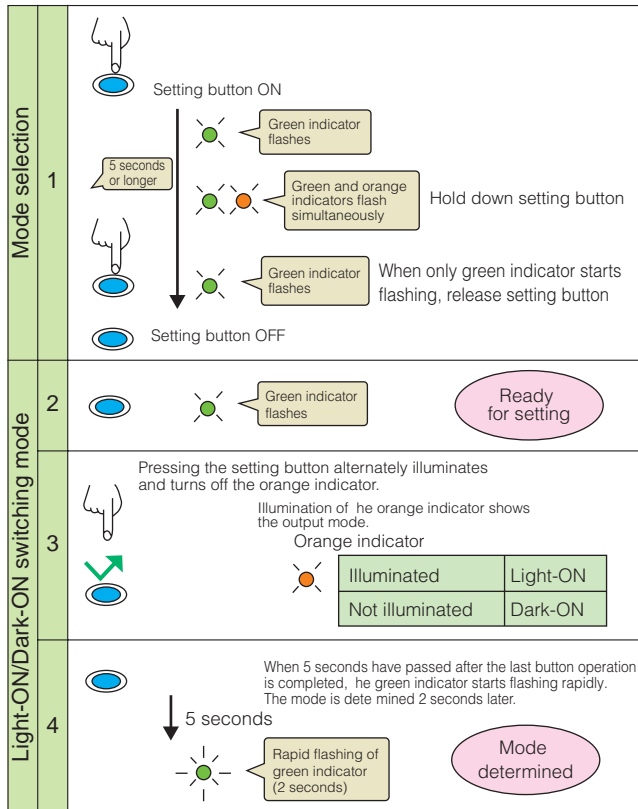

Sensitivity setting

The factory setting is maximum sensitivity. No special sensitivity adjustment is required if the detection object is something that completely blocks the light such as corrugated cardboard box. Adjust the sensitivity as required according to the state of the detection object or sensor mounting condition. Use the table below as guidelines:

Detection object	Sensitivity setting
Translucent object such as milky white plastic case	Single-touch teaching
Continuously moving object such as falling object	Full auto teaching
Object that completely blocks light such as corrugated cardboard box	Maximum sensitivity setting

Single-touch teaching —Auto teaching—

No work needs to be placed. Set the sensitivity while the light is received. Just a single operation of the button sets the optimum sensitivity for the given received light intensity.

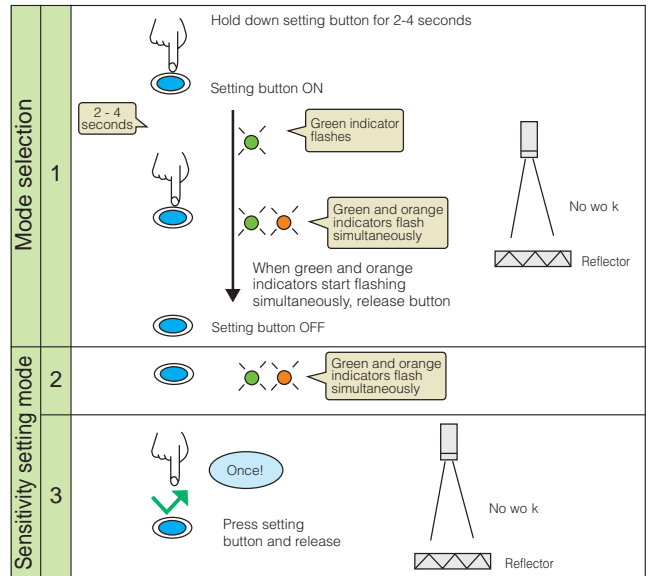

Full auto teaching

When it is not possible to make "no-work" state as in detection of continuously moving (e.g. falling) object

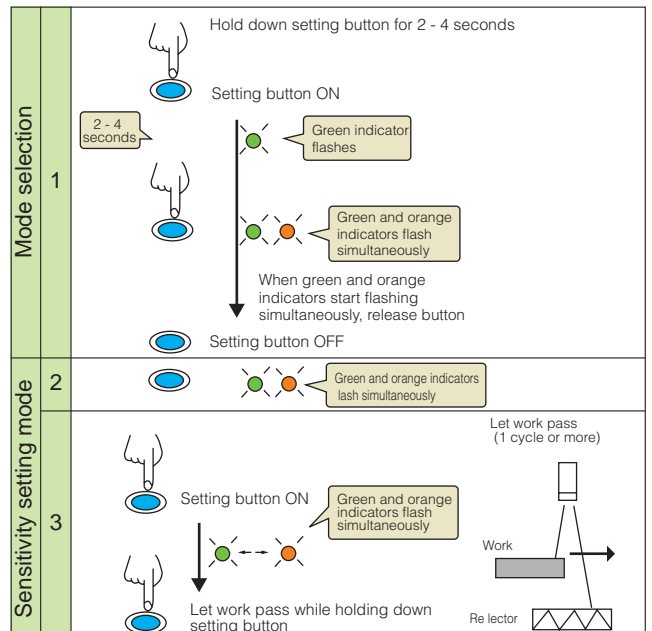

For Correct Use

Be sure to follow the instructions in the operation manual provided for correct use of the product.

Maximum sensitivity setting

Enter the sensitivity setting mode with the light blocked and press the setting button once. The sensitivity is set at the maximum, which is the factory setting.

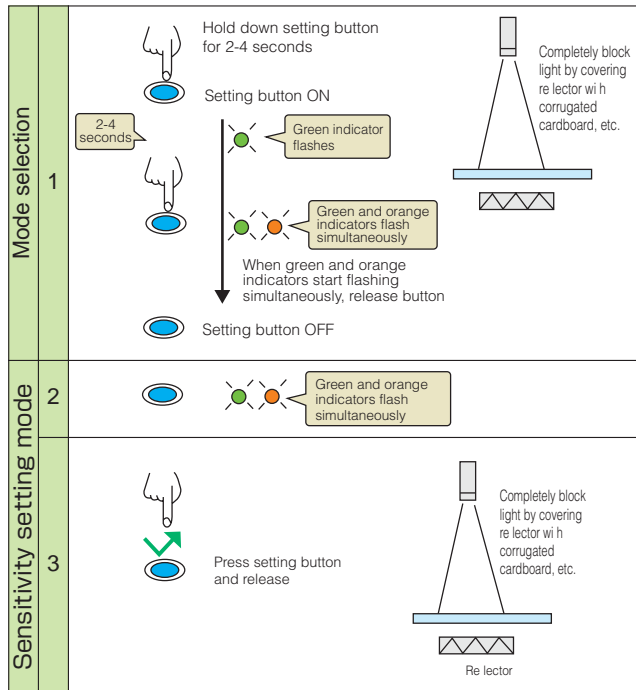

Installation

- Polarization reflectors and mounting brackets do not come with sensors. Purchase appropriate reflectors and mounting brackets according to the application.
- **Sensor mounting**
The mounting holes in the sensor are M3 threaded. Select M3 screws of an appropriate length so that the screw-in length to the body of the sensor will be at least 10 mm. The tightening torque should be up to 0.5 N·m. If the effective length of the screw to the sensor is too short, the thread of the sensor may be damaged.
- **Secure the sensor on a solid base.**
Inadequate securing allowing the sensor to move when the setting button is pressed hampers accurate sensitivity setting. Be sure to firmly secure the sensor. Make sure that the sensor and reflector are fixed before use. If the sensor or reflector is allowed to move, the operation may become unstable. Rotation of the reflector with reference to the sensor is especially likely to cause problems such as chattering.
- If the ambient temperature is low enough for freezing to occur, the operation of the setting button may not feel smooth. In such a case, press hard until the indicator flashes.

Light axis alignment

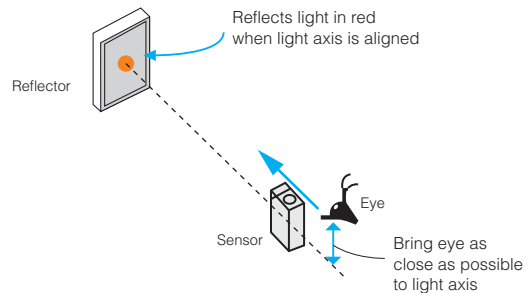

Place the reflector and sensor face-to-face and look towards the reflector from right behind the sensor. Adjust the mounting of the sensor so that the light is reflected on the reflector in red. For accurate alignment, try to look from as close to the sensor light axis as possible.

GA-S05R GA-S05RPN

For Correct Use

Be sure to follow the instructions in the operation manual provided for correct use of the product.

Part names

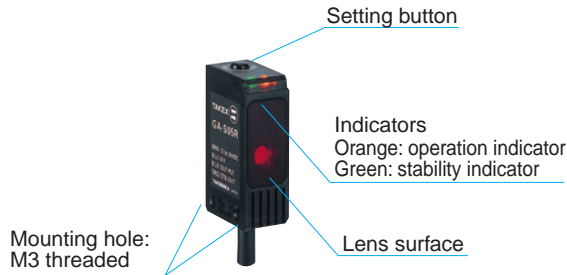

This sensor only has one setting button and no sensitivity adjustment volume or selector switch. Light-ON/Dark-ON switching and sensitivity setting are handled with the setting button alone. Enter the sensitivity setting mode or Light-ON/Dark-ON switching mode by pressing and holding down the button for a period of time as specified below:

- Hold down setting button for 2 - 4 seconds → Sensitivity setting mode
- Hold down setting button for 5 seconds or longer → Light-ON/Dark-ON switching mode

Switching between Light-ON/Dark-ON mode

The factory setting is Dark-ON mode. Be sure to check and set either the Light-ON or Dark-ON mode before setting the sensitivity. Enter the Light-ON/Dark-ON switching mode by pressing the setting button for 5 seconds or longer. While the button is operated, the state of the output before starting the operation of the button is maintained.

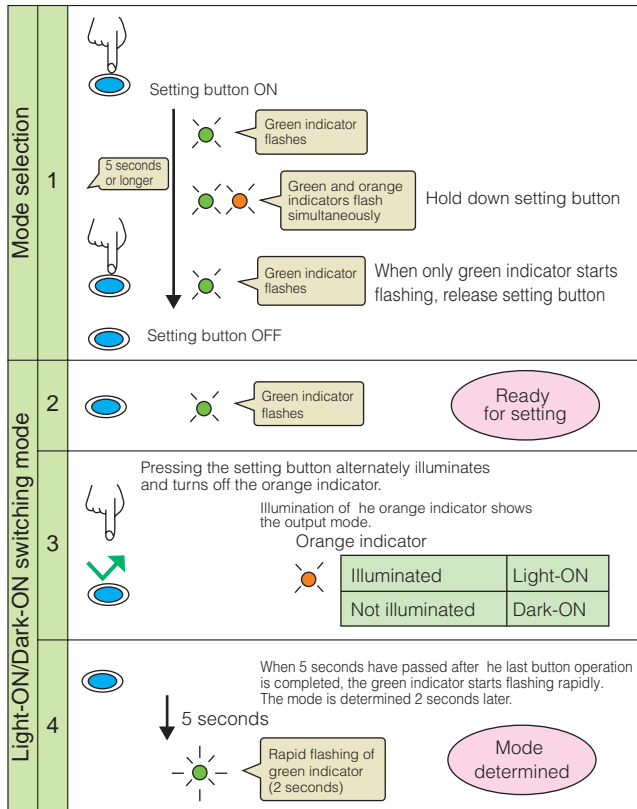

Sensitivity setting

The factory setting is maximum sensitivity. No special sensitivity adjustment is required if there is no background object in the direction of the detection. Adjust the sensitivity as required depending on whether there is any background object such as a wall or conveyor and according to the state of the detection object or sensor mounting condition. Use the table below as guidelines:

Detection object	Sensitivity setting
With background object such as wall	Single-touch teaching
Continuously moving object such as falling object	Full auto teaching

Single-touch teaching —Auto teaching—

No work needs to be placed. Just a single operation of the button sets the optimum sensitivity for the given received light intensity even an object such as wall is in the background.

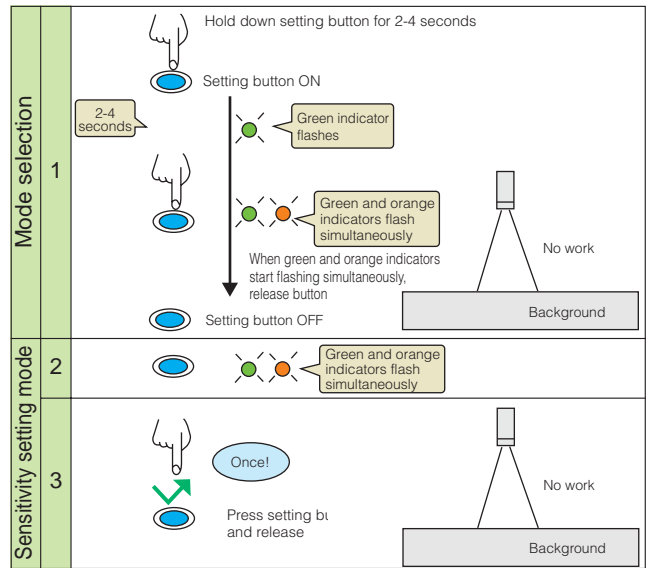

Full auto teaching

When it is not possible to make 'No-work' state as in detection of continuously moving (e.g. falling) object

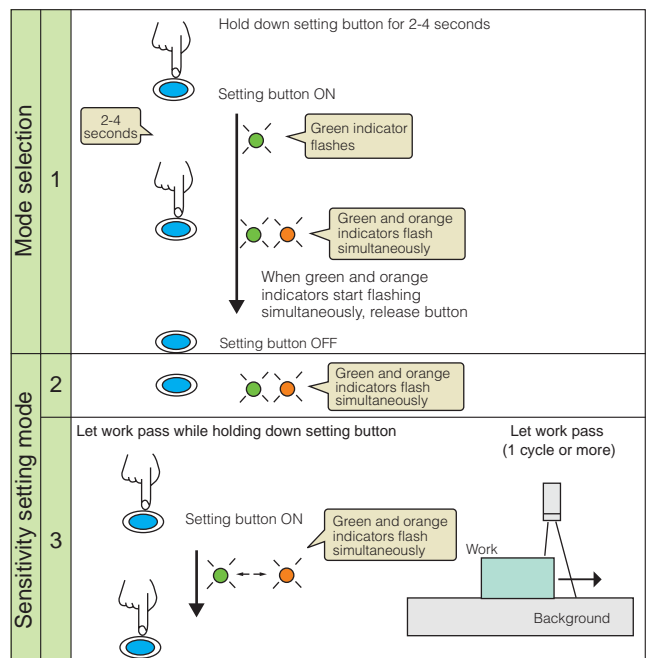

For Correct Use

Be sure to follow the instructions in the operation manual provided for correct use of the product.

Arbitrary activation position setting

To set the detection point of the sensor at an arbitrary position
Place the work at a point about 90 % of the distance to the desired activation position and select the sensitivity setting mode.
Move the work to a point about 110 % of the distance to the desired activation position and press the setting button once.

Procedure	Operation
Mode selection	<p>1</p> <p>Hold down setting button for 2-4 seconds</p> <p>2-4 seconds</p> <p>Setting button ON</p> <p>Green indicator flashes</p> <p>Green and orange indicators flash simultaneously</p> <p>When green and orange indicators start flashing simultaneously, release button</p> <p>Setting button OFF</p>
	<p>2</p> <p>Green and orange indicators flash simultaneously</p>
Sensitivity setting mode	<p>3</p> <p>Desired activation position</p> <p>Once!</p> <p>Press setting button and release</p> <p>Work</p> <p>$L2 \geq \text{Distance to desired activation position} \times 1.1$</p>
	<p>4</p> <p>Completed</p>

Although shorter distance between L1 and L2 allows more precise setting, too short a distance makes the setting similar to the single-touch teaching with only the background taken into account.

Try to make the difference between L1 and L2 at least $\pm 10\%$ of the distance to the desired activation position whenever possible.

Installation

- No mounting bracket is provided. Purchase mounting brackets separately available according to the application.
- Sensor mounting
The mounting holes in the sensor are M3 threaded. Select M3 screws of an appropriate length so that the screw-in length to the body of the sensor will be at least 10 mm. The tightening torque should be up to 0.5 N·m. If the effective length of the screw to the sensor is too short, the thread of the sensor may be damaged.
- Secure the sensor firmly on a solid base so that the sensor will not move when the setting button is pressed. Inadequate securing allowing the sensor to move when the setting button is pressed hampers accurate sensitivity setting.

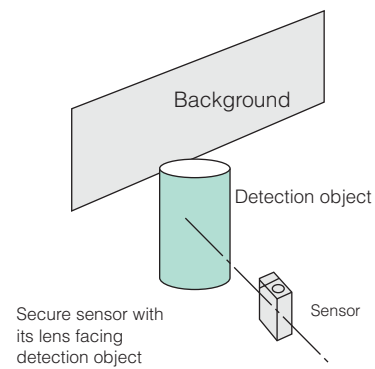

- If the ambient temperature is low enough for freezing to occur, the operation of the setting button may not feel smooth. In such a case, press hard until the indicator flashes.

Middle-G Series Embedded Amplifier Photo Sensors







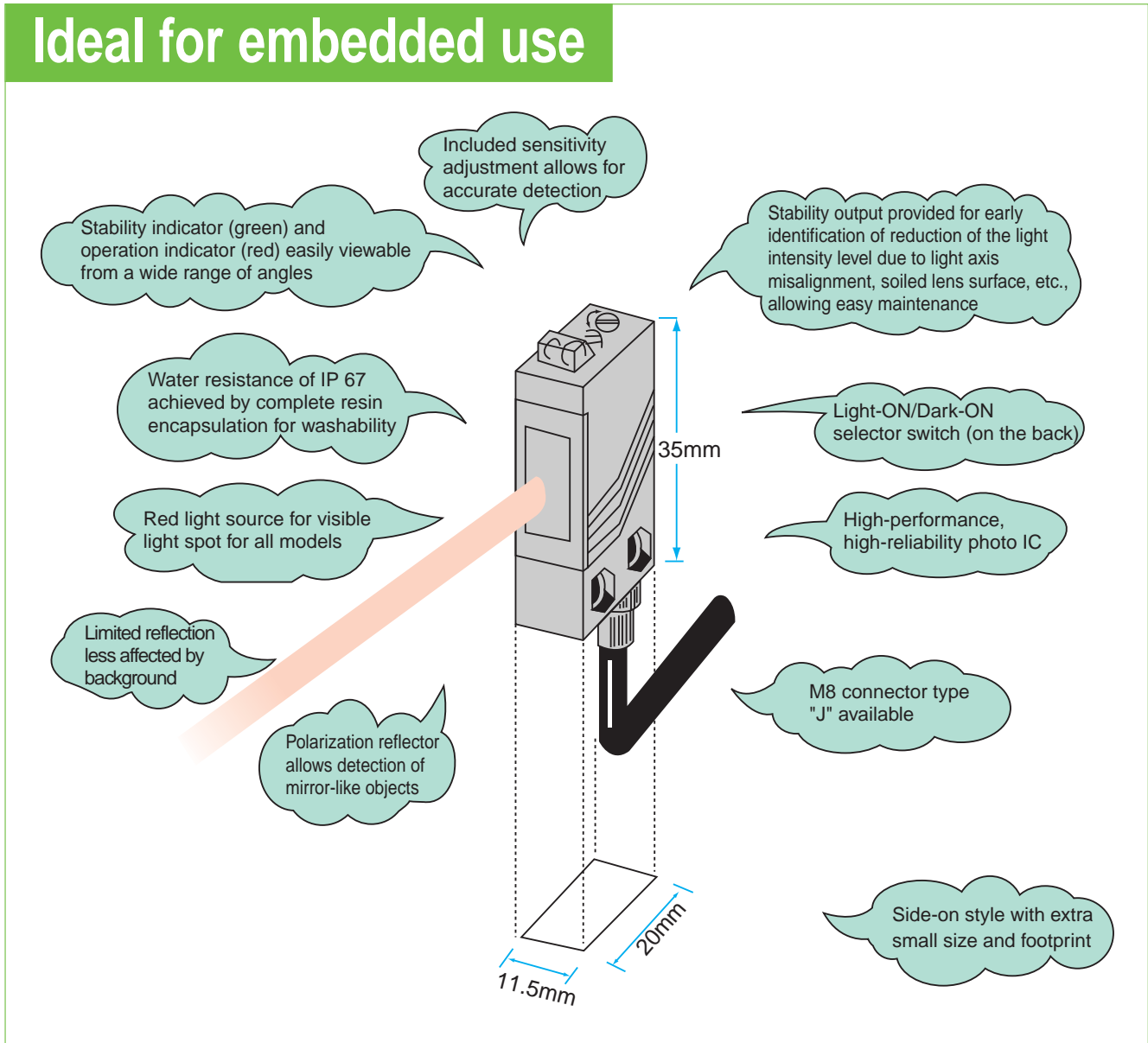

- IP 67 water resistance
- Detects mirror-like materials (mirrors, glossy objects) (polarization reflector type)
 - Switch selectable operation mode
 - Sensitivity adjustment for fine detection
 - Globally compatible PNP types also conveniently provided with stability output
 - Optional rigid protective cover (mounting bracket) available

Ideal for embedded use

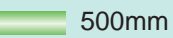

Type

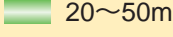
Detection method	Detecting distance	Model		Operation mode	Output mode
		Side-on type	Head-on type		
 Through-beam type	 7m	GT5RSN	_____	Light-ON/ Dark-ON selectable	NPN open collector
		GT5RSN-J	_____		
		_____	GT5RN		
		_____	GT5RN-J		
 Polarization reflector type	 0.03 -1.5m	GMR2RSN	_____		
		GMR2RSN-J	_____		
		_____	GMR2RN		
		_____	GMR2RN-J		
 Diffuse-reflective type	 500mm	GSR05RSN	_____	(with switch)	{ PNP output type also available }
		GSR05RSN-J	_____		
		_____	GSR05RN		
		_____	GSR05RN-J		
 Limited reflection type	 20~50mm	GSZ5RS	_____		
		GSZ5RS-J	_____		
		_____	GSZ5R		
		_____	GSZ5R-J		

• PNP output type

PNP output types are available for all models.

PNP output type models are identified by "PN" at the end of model number.

The rating/performance other than the output is the same as NPN type.

Protective cover

G-MSB1
(For side-on style)

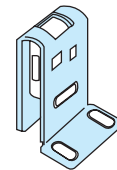

G-MTB1
(For side-on style)

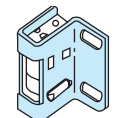

G-MTB2
(For head-on style)

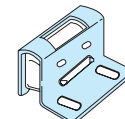

G-K7B
(For reflector)

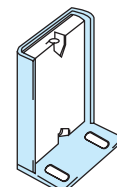

Optional Parts

Type	Model	Applicable model	Description
Reflector	K-7	All polarization reflector type models	Detecting distance With K-7: 0.03-2.5 m With S-25: 70-400 mm
	S-25 *		
Protective cover	G-MSB1	Side-on type models	Rigid SUS covers for protecting sensors and reflectors from impact, etc.
	G-MTB1	Head-on type models	
	G-MTB2		
	G-K7B	K-7 and K-71 reflectors	
Cord with M8 connector	FBC-4R2S	M8 connector type sensor models with "-J"	Straight (2 m)
	FBC-4R2L		Angled (2 m)

* One sheet contains 25.

For dimensions, see "Dimensions (protective cover)."

Middle-G

Rating/Performance/Specification

Model	Side-on	GT5RSN	GMR2RSN	GSR05RSN	GSZ5RS
	Head-on	GT5RN	GMR2RN	GSR05RN	GSZ5R
Detection method		Through-beam type	Polarization reflector type	Diffuse-reflective type	Limited reflection type
Detecting distance		7m	0.03 - 1.5m*	500mm	20 - 50mm
Detection object		φ 20mm (Min.) Opaque	Glossy objects including mirror-like materials and stainless-steel plates or opaque objects	Standard detection object: 100 x 100mm white drawing paper	_____
Power supply		12 - 24V DC ±10% / Ripple 10% max. (*15 V power supply)			
Current consumption		Transmitter: 20 mA max. Receiver: 20 mA max.	30mA max.		
Output mode	Control output	NPN open collector output Rating: sink current 100 mA (30 V DC) max. (PNP output type also available)			
	Stability output	NPN open collector output Rating: sink current 50 mA (30 V DC) max. (PNP output type also available)			
Operation mode		Light-ON/Dark-ON selectable (with switch)			
Response time		0.5ms max.			
Hysteresis		_____		10% max.	
Operating angle		10° (at receiver)	30° (reflector)	_____	
Light source (light wavelength)		Red LED (700nm)			
Indicator		Transmitter: power indicator (red LED) Receiver: operation indicator (red LED) Stability indicator (green LED)	Operation indicator (red LED) Stability indicator (green LED)		
Volume		SENS: sensitivity adjustment (on receiver for through-beam type)			
Switch		Light-ON/Dark-ON selector switch provided			
Short circuit protection		Provided (for control output only)			Provided
Material	Case	Polyarylate			
	Lens	Acrylic			
Connection		Permanently attached cord (outer dimension: dia. 4.2) Transmitter of through-beam type: 0.3 sq. 2 core 2 m length(gray) Receiver of through-beam type: 0.2 sq. 4 core 2 m (black)			
Mass		About 80 g (transmitter/receiver)	About 80g		
Notes		K-71 reflector provided		Screwdriver for sensitivity adjustment provided	
		*1 Contact Takex for 5 VDC power supply models available for head-on types. ● All models are provided with a mounting bracket. Polarization reflector types are provided with a bracket for reflector and adhesive sheet for mounting the reflector.			

Environmental Specification

Ambient light	5,000 lx max.
Ambient temperature	-25 - +55°C (non-freezing)
Ambient humidity	35~85%RH (non-condensing)
Protective structure	IP67
Vibration	10-55 Hz / 1.5 mm amplitude / 2 hours each in 3 direction
Shock	500 m/s ² / 3 times each in 3 directions
Dielectric withstanding	1,000 VAC for 1 minute
Insulation resistance	500 VDC, 20 MΩ or higher

*Detecting distances for different reflectors

- The detecting distance depends on the reflector used.

Reflector model	K-71	K-7	S-25
Detecting distance	0.03 - 1.5m	0.03 - 2.5m	70 - 400mm

Input/Output Circuit and Connection

NPN output

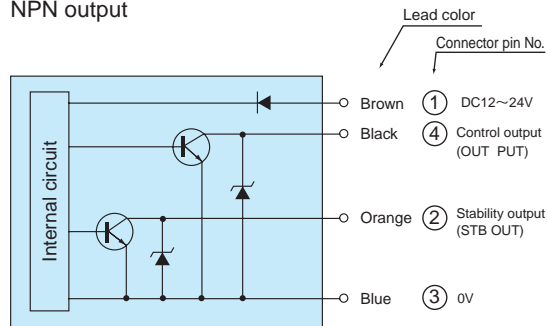

PNP output

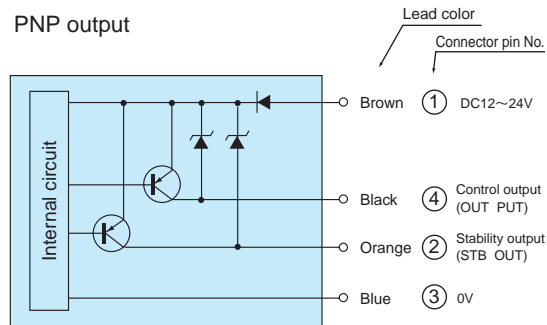

- The transmitter is provided with power supply lines (brown: 12-24 VDC; blue: 0 V) only.
- The output transistor turns off when load short circuit or overload occurs.
- Check the load and turn the power back on.

• M8 connector type (-J) pin assignment and connection (Receiver/reflective type sensor)

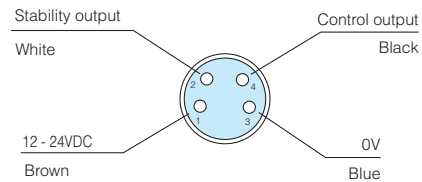

The colors show lead colors for use in combination with the optional cord with M8 connector.

(Transmitter)

Lines other than Lines 1 (brown) and 3 (blue) are unused.



Characteristics (Typical Example)

• Directional characteristics

GT5RSN · GT5RN

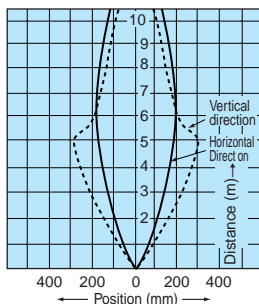

GMR2RSN (K-7)
GMR2RN (K-71)

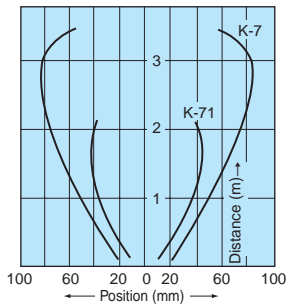

GMR2RSN (S-25)
GMR2RN (S-25)

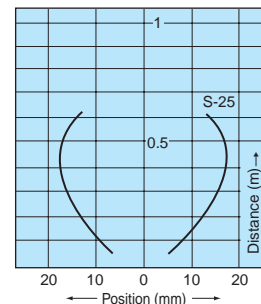

• Operating angle characteristics

GMR2RSN · GMR2RN

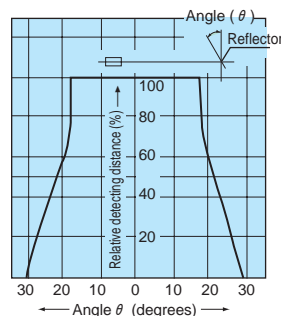

• Activation area characteristics

GSR05RSN · GSR05RN

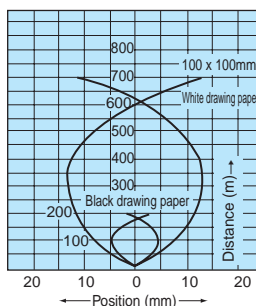

• Distance-area characteristics

GSR05RSN · GSR05RN

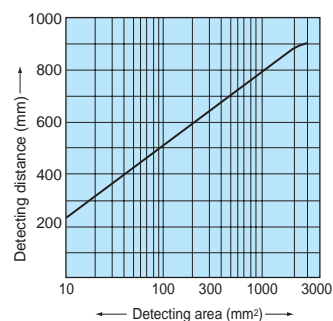

Middle-G

Dimensions (in mm; tightening torque for mounting screws: 0.6 N·m max.)

GT5RN
GMR2RN
GSR05RN
GSZ5R

CAD

(Head-on) typical example

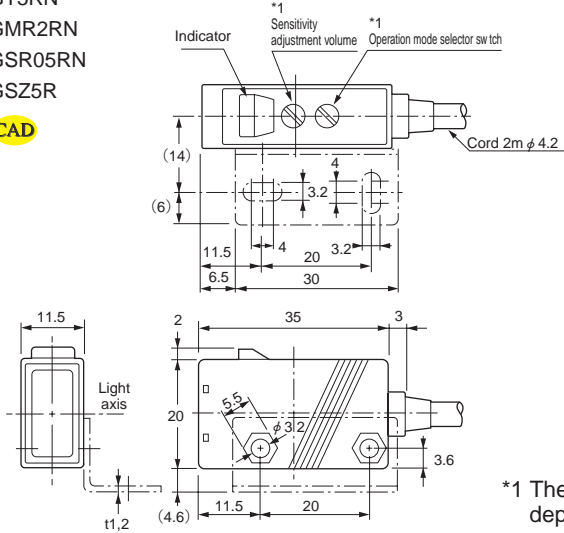

(Side-on) Typical example

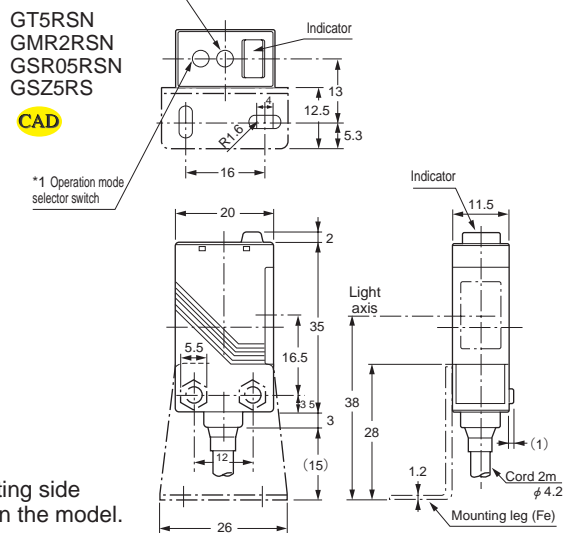

*1 The operating side depends on the model.

CAD

(K-71 reflector)

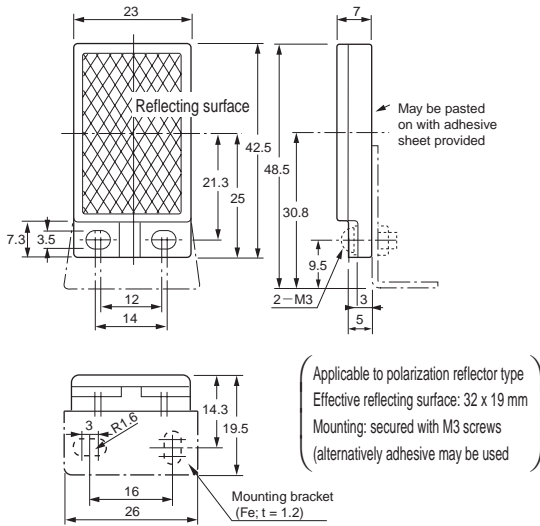

(Mounting bracket in different orientation)

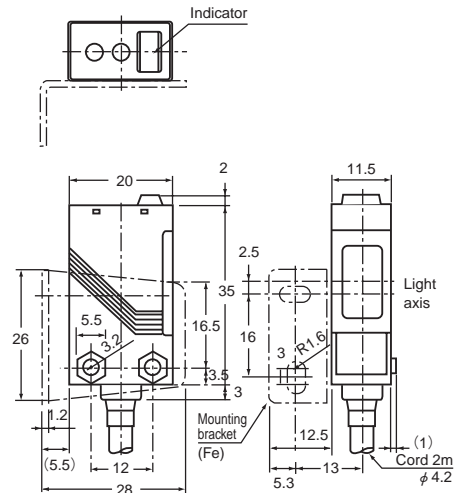

CAD

"-J" (M8 connector type) head-on model

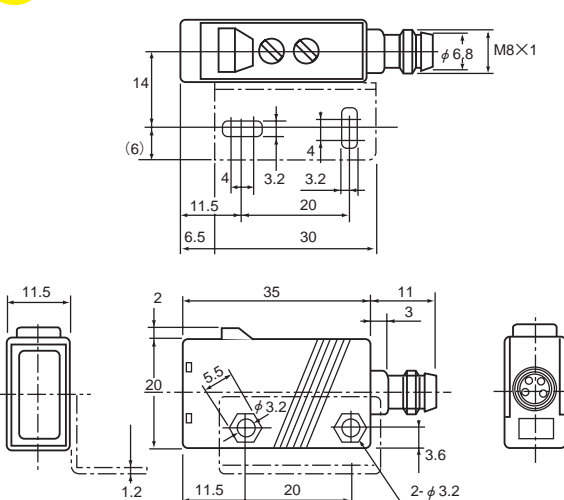

CAD

"-J" (M8 connector type) side-on model

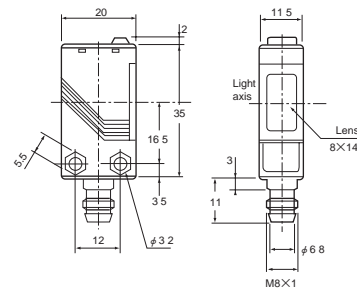

FBC-4R2S (Straight)

CAD

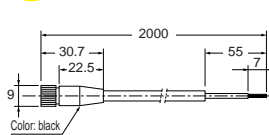

FBC-4R2L (Angled)

CAD

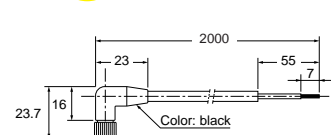

Dimensions (protective cover) (in mm)

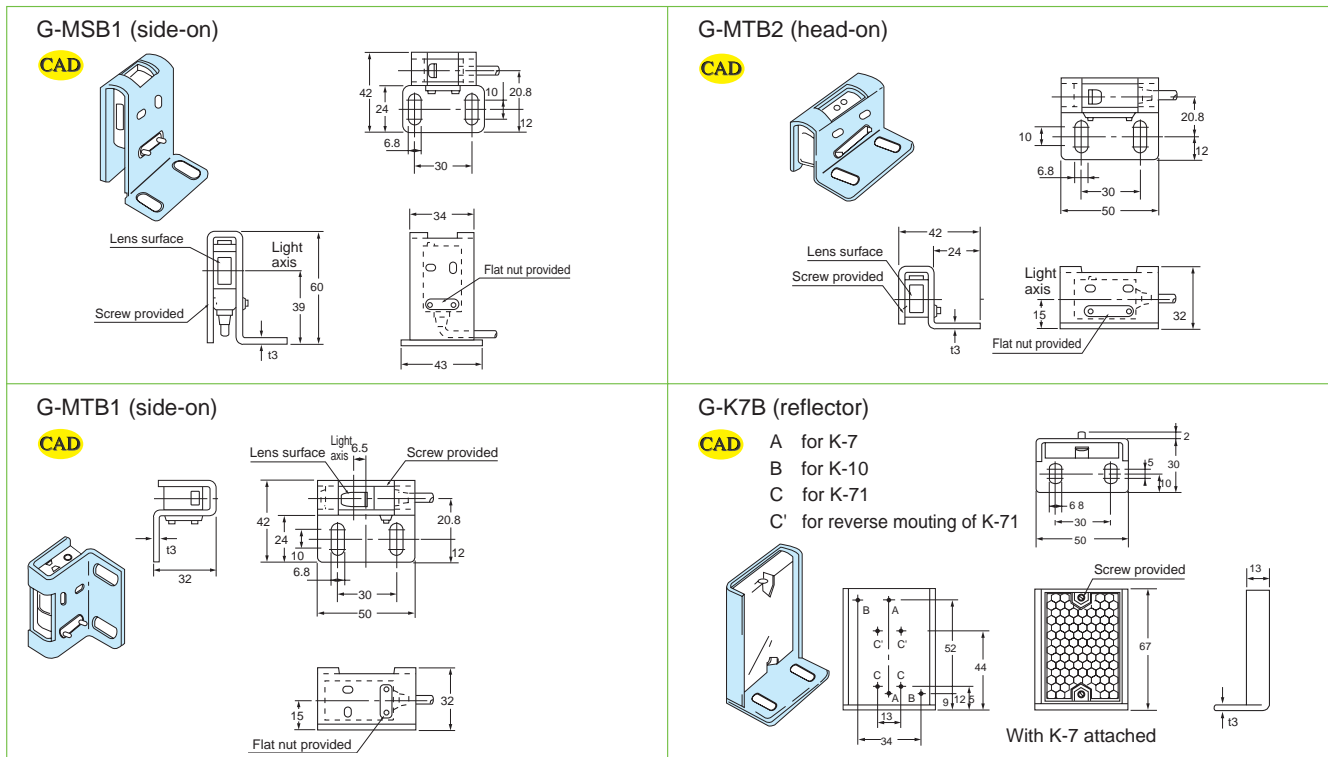

Operation Mode Switching

- Operation mode selector switch is provided for all models.

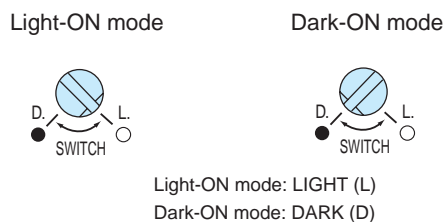

Indicators

- The operation indicator (red LED) and stability indicator (green LED) show the levels of light intensity as described in the figure below.
- After aligning the optical axis and adjusting the sensitivity, use a detection object to block and unblock the light beam several times to make sure that the sensitivity level is in a range that allows stable activation and deactivation.
- Setting the sensitivity in a range allowing stable operation achieves higher reliability against changes in the operating environment generated after the sensitivity is set.

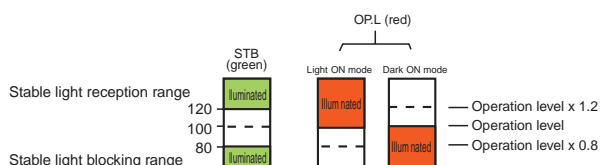

The red LED (OPL) is the operation indicator.
In the L.ON (Light-ON) mode, the indicator is illuminated when a certain amount of light is detected.
In the D.ON (Dark-ON) mode, the indicator is illuminated when a certain amount of light is not detected.

Stability output

The stability output can be used to check for reduction of the light intensity level along with any change in the operating environment or operation over time or to perform initial check of the operation. When two consecutive detections have occurred with the intensity of light detected exceeding the operation level but not reaching 120 % of the level (range allowing stable operation), the stability signal is output when the control output is deactivated.

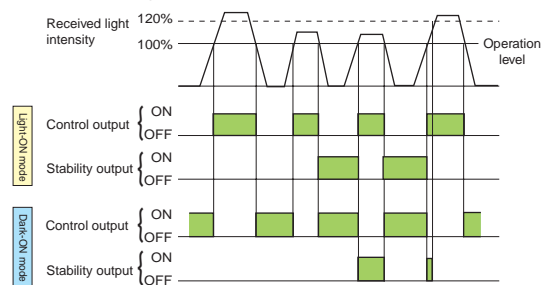

Sensitivity adjustment (for diffuse-reflective type)

(Adjustment for Light-ON mode)

- When any light-reflecting object is in the background
 - Place the object to be detected in a given position, turn up the sensitivity adjustment volume (SENS.) gradually and find the point at which the operation indicator (red LED) is illuminated (Point A).
 - Remove the object, turn down the sensitivity adjustment volume gradually from MAX. and find the point at which the operation indicator (red LED) goes out (Point B). (If the operation indicator is not illuminated even at Max., MAX. is regarded as Point B.)
 - Set the volume at midway between Points A and B.



NT30F Series

Embedded Amplifier Photo Sensors

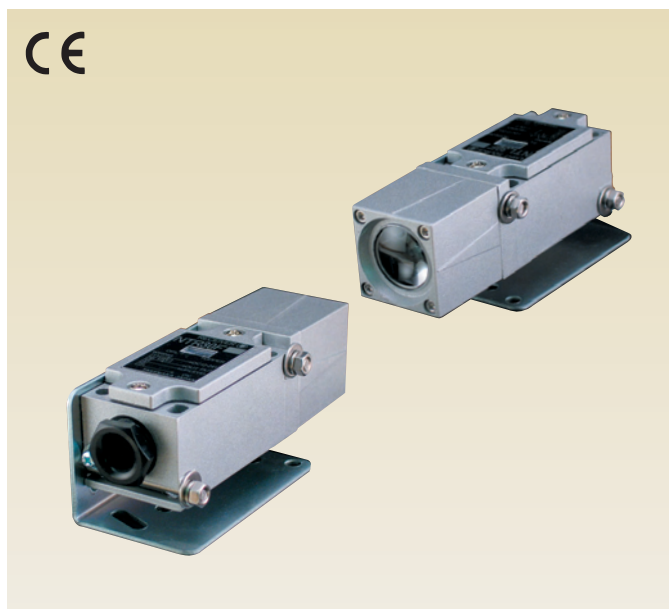

CE

- Self-diagnostic feature
- High power for reliable detection in adverse environment
- Long distance detection of up to 30 m
- DIN compatible zinc die-cast case
- Receiver provided with "stability output circuit" for monitoring adequate light reception together with indicator and output terminal. Also equipped with monitor output jack for additional reliability in light axis alignment by use of earphone and Light-ON/Dark-ON selector switch.
- Transmitter provided with "check signal input terminal" and "monitor output" for overall operation checking of transmitter and receiver.

Type

Detection method	Detecting distance	Model	Operation mode	Output mode
 Through-beam type		NT30F	Light-ON/Dark-ON selectable (with switch)	Current output/voltage output

- Extra long-distance of 50 m and 100 m also available
Models allowing even longer detecting distance are also available.
50 m type: model NT50 / 100 m type: model NT100

Optional Parts

Type	Model	Description	
Pinhole plate	30P1	$\phi 1$	Reduces the smallest allowable detection object diameter and activation area. Note that detecting distance is reduced as well.
	30P3	$\phi 3$	
	30P5	$\phi 5$	
	30P7	$\phi 7$	
	30P10	$\phi 10$	
Earphone	EC30	Simplifies light axis alignment for long-distance setting by monitoring sound.	
Hood	H301	Hood for shielding from outside light.	
	F301	Hood for shielding from outside light. Energy-saving airless dust hood taking advantage of muffler effect for preventing soiling of lens.	
	A301	Air purge hood.	

Model Equipped with Water-Cooling Jacket

Water-cooling type	NTL30FW	Transmitter	For protecting sensor from ambient temperature
	NTR30FW	Receiver	

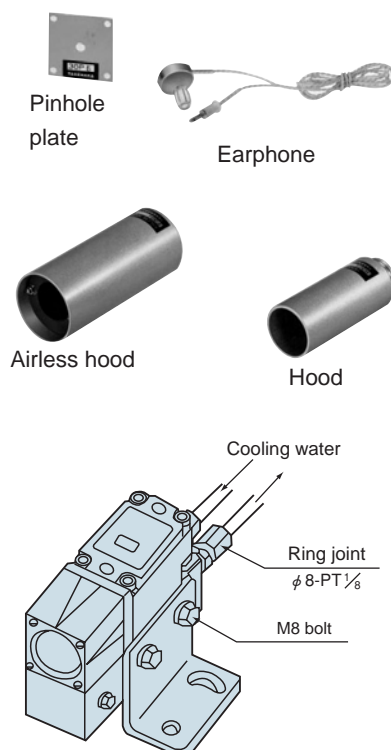

Rating/Performance/Specification

Model		NT30F	
Rating/performance	Detection method	Through-beam type	
	Detecting distance	30m	
	Detection object	φ 22mm (Min.) Opaque	
	Power supply	12 - 24V DC ±10% / Ripple 10% max.	
	Current consumption	Transmitter: 50 mA max. Receiver: 35 mA max.	
	Output mode	Current output/voltage output (Rating) Current output : sink current 100 mA (30 VDC) max. Voltage output: output impedance 4.7 kΩ	
	Operation mode	Light-ON/Dark-ON selectable (with switch)	
	Self-diagnosis feature	(Transmitter) Check signal input (Terminal No. 4) Monitor output (Terminal No. 3): activated when normal (For current/voltage: sink current 100 mA (30 VDC) max. output impedance 4.7 kΩ)	
		(Receiver) Stability output (Terminal No. 4): activated when abnormal (NPN open collector sink current 100 mA (30 VDC) max.) Received light monitor, earphone jack terminal	
	Response time	5ms max. (*0.5ms)	
Specification	Light source	Infrared LED	
	Indicator	(Transmitter) P.L power indicator (red LED) NORM.OP: monitor output indicator (green LED)	(Receiver) OP.L operation indicator (red LED) UP: Stability indicator (green LED)
		Switch (SW)	Light-ON/Dark-ON selector switch provided
	Short circuit protection	provided	
	Case material	Zinc die-cast	
	Connection	Terminal block connection (screw: M3.5; terminal pitch: 8.1 mm)	
	Mass	About 700 g (transmitter/receiver)	

Environmental Specification

Environment	Specification
Ambient light	20,000 lx max.
Ambient temperature	-25 - +55°C (non-freezing) *1
Ambient humidity	35~85%RH (non-condensing)
Protective structure	IP66
Vibration	10 - 55 Hz / 1.5 mm amplitude / 2 hours each in 3 direction

*High-speed response type (0.5 ms) also available: model NT30FA

*1 Some models may be used in environment of 110 °C by attaching water-cooling jacket.

Terminal Block and Connection

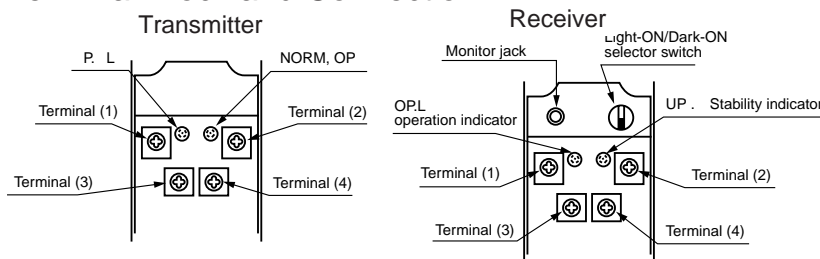

Terminal (1) Power supply 12 - 24VDC
Terminal (2) 0V
Terminal (3) monitor output
Voltage/current output
Terminal (4) Check signal input
Indicator P.L: power indicator (red LED)
Indicator NORM.OP: monitor output (green LED)

Terminal (1) Power supply 12~24VDC
Terminal (2) 0V
Terminal (3) Output: voltage/current output
Terminal (4) Stability output (current output)
Open collector
Indicator O.P.L operation indicator (red LED)
Indicator UP: Stability indicator (green LED)
Selector switch: Light-ON/Dark-On selector switch
Monitor jack: for earphone for light axis alignment

Note) Be sure to use the earphone specified (EC30 separately available).

Operation and Stability Indicators

When the received light intensity is under the operation level, neither of the indicator is illuminated.

When the light intensity reaches the operation level, OP.L is illuminated (with selector switch set to LIGHT).

When the light intensity reaches twice as much as the operation level, the stability indicator UP is illuminated.

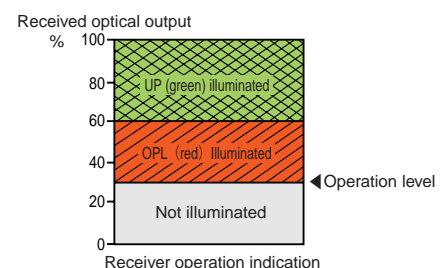

NT30F

Input/Output Circuit and Connection

Transmitter (NTL30F)

Power supply connection

Indicator illuminated when power is supplied, indicating normal operation

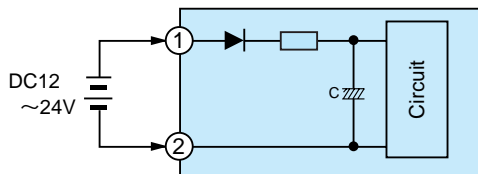

(For use of check signal input (HOLD))

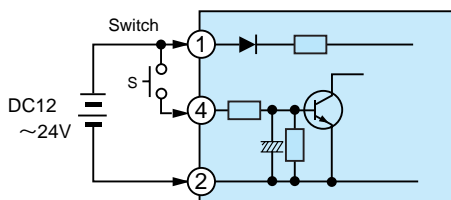

Connect a switch, etc. between Terminals (1) and (4) (normally-open contact) and press the switch. The light emission stops after about 25 ms and the output level turns H.

Use of monitor output

(For relay output (control))

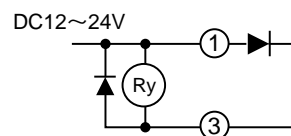

Relay activated when normal (relay of 30 VDC, 100 mA max.)

(For voltage output)

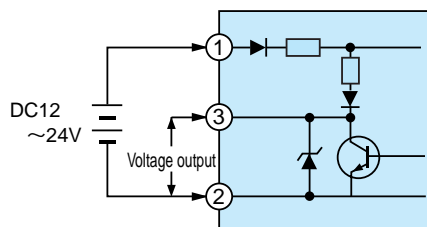

Light emission state = indicator (NORM.OP) illuminated
output: ON (level)

Receiver (NTR30F)

Output connection

Terminal assignment for power supply same as transmitter:

(For relay output)

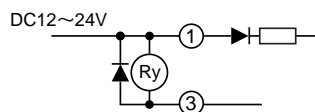

(relay of 30 VDC, 100 mA max.)

(For voltage output)

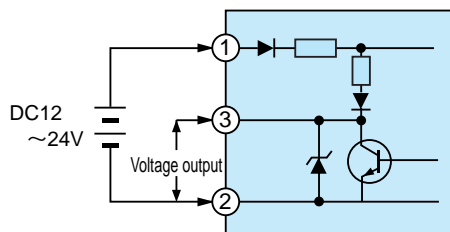

Output mode selectable with switch between Light-ON/Dark ON

(For use of stability output)

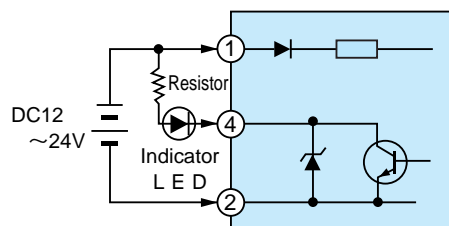

Abnormal: ON (L level) indicator illuminated
Note) Connect a resistor in series with the indicator.
(Hint) Resistance: 2 - 4 KΩ

(For voltage output)

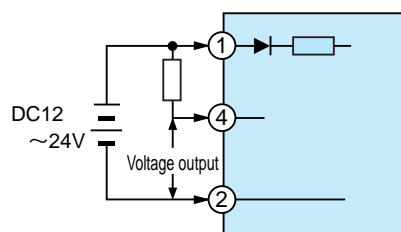

Connect a resistor between Terminals (4) and (1) for voltage output between Terminal (4) and (2).
Output between Terminals (4) and (2): OFF (H level) when normal.

Characteristics (Typical Example)

Directional characteristics

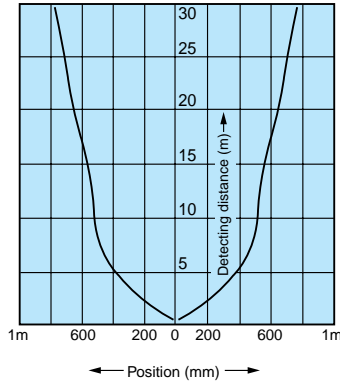

Distance-output characteristics

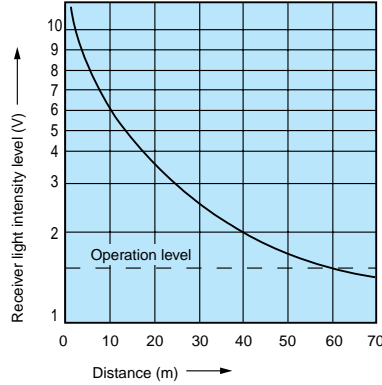

Temperature characteristics

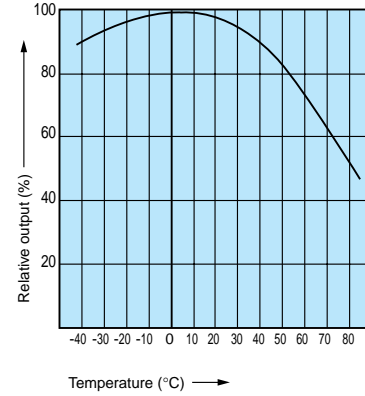

Dimensions (in mm)

CAD

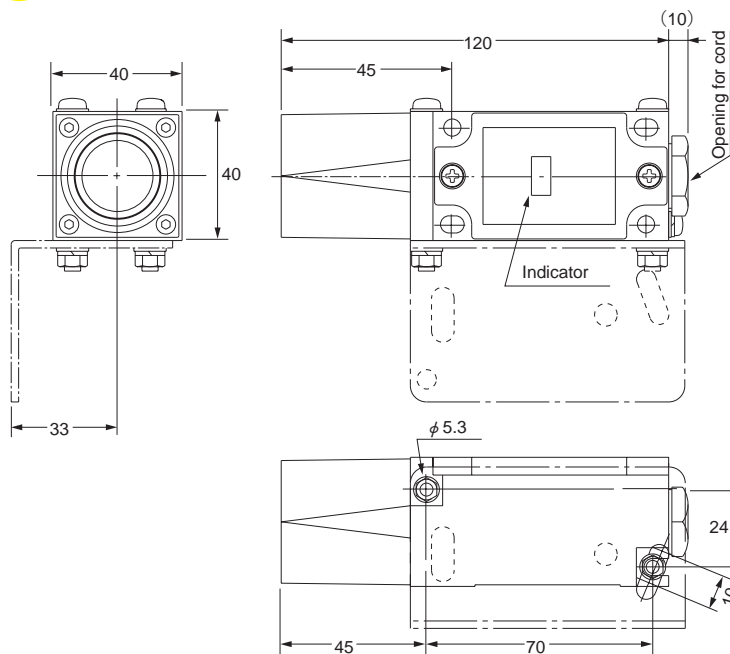

For connection, use cables of 9-11 mm in diameter.
Loosen the screws on the lid of the body to remove the lid.
For mounting, use a solid base not subject to vibration.
Use 2 M6 bolts for securing the sensor body (separately prepare bolts, nuts, washers, etc.).

Mounting bracket (accessory)

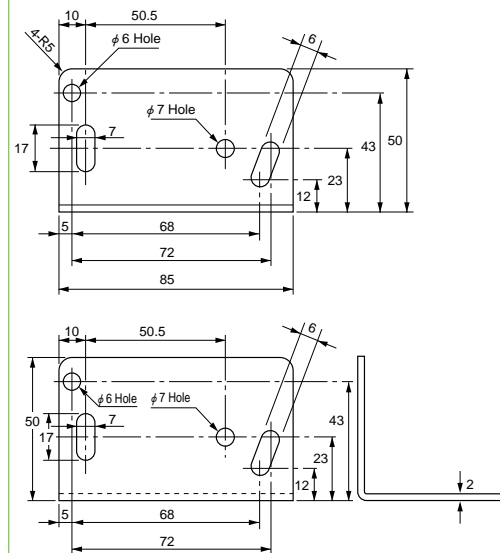
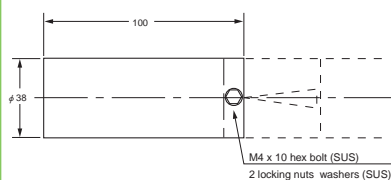

Plate thickness: 2 mm

(NT30F + H301 hood)

CAD



(NT30F + F301 airless hood)

CAD

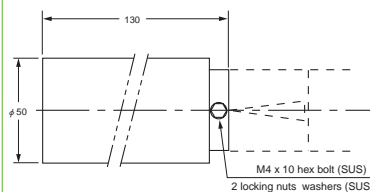

(NT30F + A301 air purge hood)

CAD

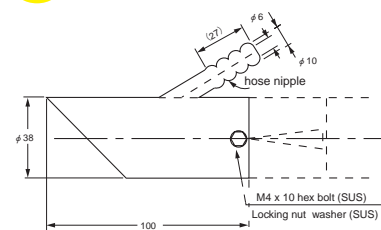



- M18 cylindrical type compatible with European Standards (CENELEC)
- Polarization reflector type capable of detecting mirror-like objects
 - Thorough short circuit protection
 - Water resistance of IP 66 achieved by resin molding
 - Dramatic improvement of environment resistance including prevention of damage and falling off electronic components caused by vibration and enhanced robustness

Type

Detection method	Detecting distance	Model		Operation mode	Output mode	Remarks
		NPN type	PNP type			
Through-beam type 	3m	CXT8 ※	CXT8PN ※	Light-ON /Dark-ON selectable (with control lead)	Open collector	Infrared LED long-distance type
Polarization reflector type 	2 m max.	CX-M2RD	CX-M2RDPN	Dark-ON		Red LED capable of detecting mirror-like objects
Diffuse-reflective type 	100 mm max.	CX-R01	CX-R01PN	Light-ON		Infrared LED
	300 mm max.	CX-R03V	CX-R03VPN		Infrared LED type provided with adjustment for ease of fine detection	

*Connector connection models convenient for mounting and wiring also available

Models CXT8-J, CXT8PN-J

Cord with connector separately available required for connector connection models

Model CX-C4 — 4-core, 2.5 m

Rating/Performance/Specification

	Model	NPN type	CXT8	CX-M2RD	CX-R01	CX-R03V	
		PNP type	CXT8PN	CX-M2RDPN	CX-R01PN	CX-R03VPN	
Rating/performance	Detection method	Through-beam type		Polarization reflector type	Diffuse-reflective type		
	Detecting distance	3m		2m*1	100mm *2	300mm *3	
	Detection object	φ 15mm (Min.) Opaque		Mirror-like objects / opaque objects / translucent objects	Opaque objects / translucent objects		
	Power supply	12 - 24V DC ±10% / Ripple 10% max.					
	Current consumption	NPN type	Transmitter: 25 mA max. Receiver: 15 mA max.		20mA max.	17mA max.	20mA max.
			PNP type	Transmitter: 25 mA max. Receiver: 20 mA max.		24mA max.	23mA max.
	Output mode	NPN type		Open collector Rating: sink current 100 mA (30 VDC) max.			
		PNP type	Open collector Rating: source current 100 mA (30 VDC) max.				
	Operation mode	Light-ON/Dark-ON selectable (with control lead)		Dark-ON	Light-ON		
	Response time	1ms max.		0.35ms max.			
Operating angle	7° (at receiver)		10° (at receiver)	_____			
Hysteresis	_____		5% max.				
Specification	Light source (wavelength)	Infrared LED (940nm)		Red LED (700nm)	Infrared LED (950nm)		
	Indicator	Transmitter: Power indicator (red LED) Receiver: Light reception indicator (red LED)		Operation indicator (red LED)			
	Volume	_____				Sensitivity adjustment	
	Short circuit protection	Provided					
	Material	Lens: Polycarbonate Case: Polycarbonate		Lens: Acrylic Case: Polycarbonate	Lens: Polycarbonate Case: Polycarbonate		
	Connection	Permanently attached cord (outer diameter: 4 mm) Transmitter: 0.2 sq. 2 core 2 m length (gray) Receiver: 0.2 sq. 4 core 2 m length (black)		Permanently attached cord (outer dimension: dia. 4) 0.2sq. 3 core 2 m length (black)			
	Mass	Transmitter: About 65 g Receiver: About 65 g		About 65 g			
Notes	Slit plate (optional) 3 x 10, 4 x 10, 5 x 10 in 1 set		K-7 reflector provided		_____		

*1 With K-7 reflector

*2 With 50 x 50 mm white drawing paper

*3 With 100 x 100 mm white drawing paper

Environmental Specification

Environment	Ambient light	10,000 lx max. (5,000 lx max. for through-beam type)
	Ambient temperature	-25 - +55°C (non-freezing)
	Ambient humidity	35 - 85%RH (non-condensing)
	Protective structure	IP66
	Vibration	10 - 55 Hz / 1.5 mm amplitude / 2 hours each in 3 direction
	Shock	100 m/s ² / 3 times each in 3 directions
	Dielectric withstanding	500 VAC for 1 minute
	Insulation resistance	500 VDC, 20 MΩ or higher

• Applicable power supply unit

PS Series
High capacity of 200 mA at 12 VDC



(General-purpose type) PS3N
PS3N-SR
(Multifunctional type) PS3F
PS3F-SR

Input/Output Circuit and Connection

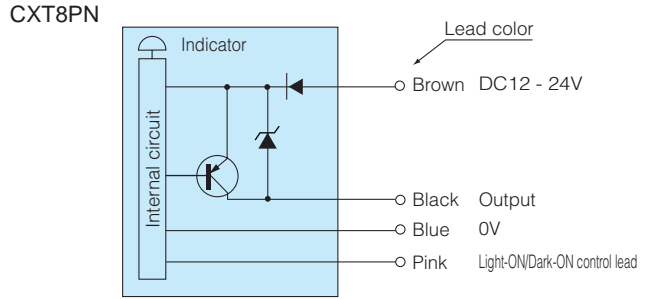
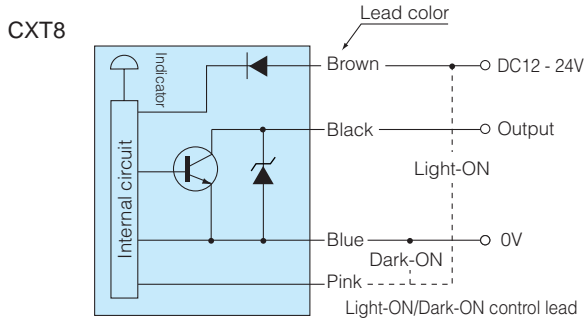

CX-M2RD **NPN output**
CX-R01
CX-R03V

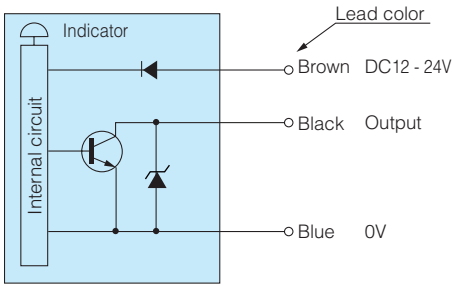

CX-M2RDPN **PNP output**
CX-R01PN
CX-R03PN

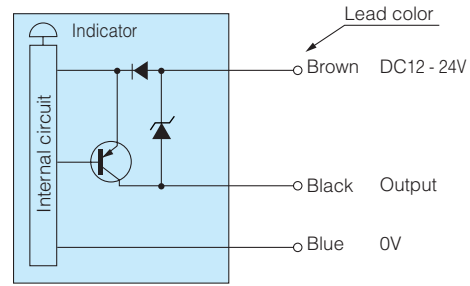

• The output transistor turns off when load short circuit or overload occurs. Check the load and turn the power back on.

Characteristics (Typical Example)

• Directional characteristics

CXT8

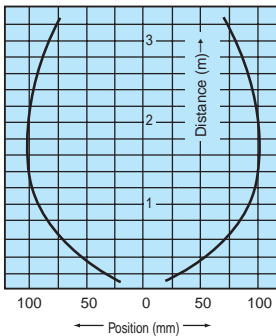

CX-M2RD · CX-M2RDPN

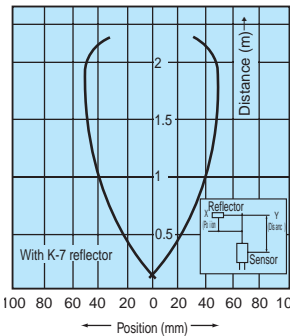

CX-R01 · CX-R01PN

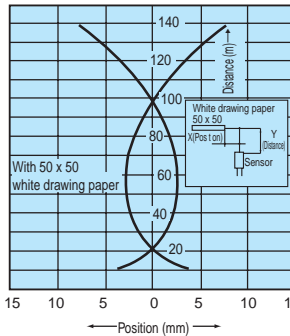

CX-R03V · CX-R03VPN

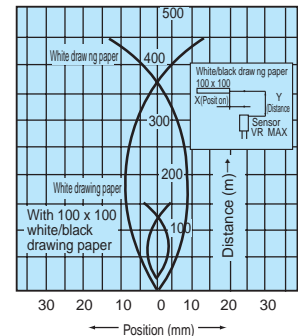

• Operating angle characteristics

CXT8 (PN)

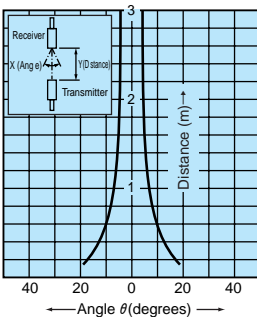

• Distance-output characteristics

CX-R01 · CX-R01PN

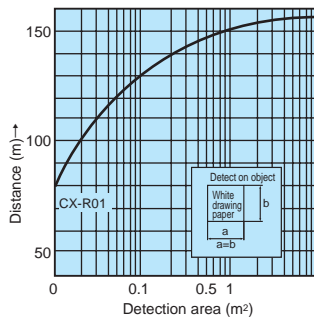

CX-R03V · CX-R03VPN

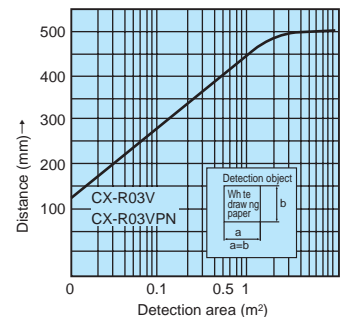

Temperature characteristics

CX-M2RD
CX-M2RDPN

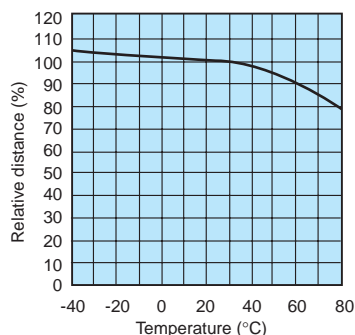

CX-R01
CX-R01PN
CX-R03V
CX-R03VPN

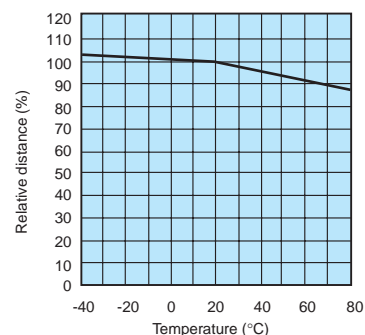

Dimensions (in mm)

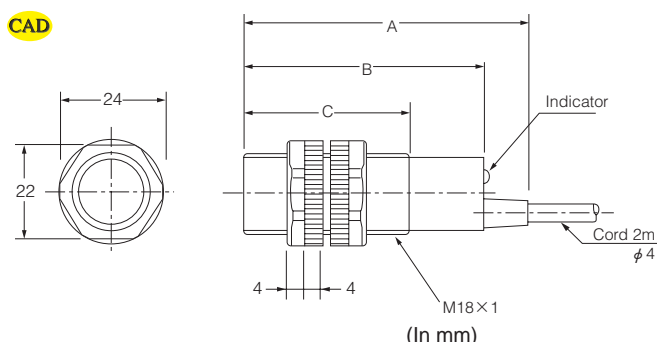

Model	A	B	C
CX-M2RD CX-M2RDPN	66.2	56.2	38.2
CXT8 CX-R01 CX-R01PN CX-03V CX-R03VPN	65	55	37

CAD K-7 reflector

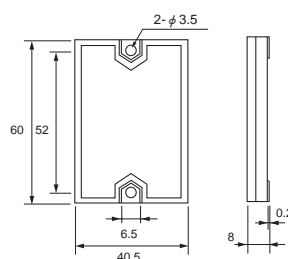

(Applicable to polarization reflector type)
Effective reflecting surface : 56 x 36 mm
Mounting: secured with M3 screws
(alternatively adhesive may be used)
Protective structure: IP 67

(Notes on mounting)

- Excessive tightening torque may damage the thread of the nut to cause loosening. Make sure that the tightening torque is up to 0.98 N·m.
- This sensor does not allow adjustment of mounting angle once it is secured. Pay attention to the light axis especially for through-beam types to avoid misalignment.

Setting

(Through-beam type)

- For light axis alignment, swivel the receiver vertically and horizontally to install it at the center of the area in which the light reception indicator (red LED) is illuminated for the individual direction.
- Repeat activation and deactivation to check the operation.

(Polarization reflector type)

- Arrange the sensor in line with the reflector. Swivel the sensor vertically and horizontally with reference to the reflector, use the operation indicator to check the area in which the sensor is activated (indicator goes out) and install the sensor at the center of the area. Taking advantage of the red light spot on the reflector seen from behind the sensor allows easy setting.

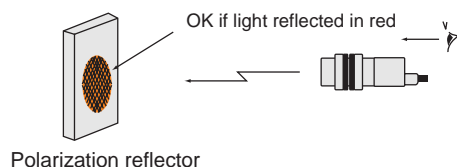

(Diffuse-reflective type)

- Set the sensor so that the operation indicator (red LED) is illuminated with the detection object placed at a given position and not illuminated with the object removed.
- Bring any background of the detection object as far away as possible or use black surface with low reflectance.
- The detecting distance depends on the surface condition of the detection object. This sensor is not provided with a sensitivity adjustment volume and needs to be adjusted for stable operation by changing the distance, angle, background object, etc.

(Diffuse-reflective type with adjustment)

- Adjustment with any light-reflecting object in the background
 - Place the object to be detected in a given position, turn up the sensitivity adjustment volume (SENS) gradually from the minimum (MIN) and find the point at which the operation indicator (red LED) is illuminated (Point A).
 - Remove the object, turn down the sensitivity adjustment volume gradually from the maximum (MAX) and find the point at which the operation indicator (red LED) goes out (Point B). (If the operation indicator is not illuminated even at MAX, MAX is regarded as Point B.)
 - Set the volume at midway between Points A and B.





- Stable detection performance by limiting detection zone for less influence of disturbance

Reflective type photo sensor with light axes of transmitter and receiver crossed at about 20 mm from sensor for limiting detection zone

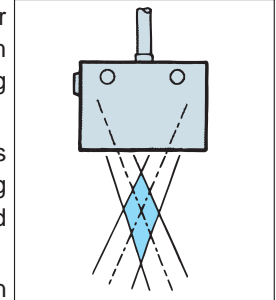

- Detection method less affected by disturbing external or background reflection
- Highly-accurate detection achieved by restricting detection zone

Type

Detection method	Detecting distance	Model	Operation mode	Output mode
 Limited reflection type	 10~30mm	DLZ-S30	Light-ON	NPN open collector
		DLZ-S30D	Dark-ON	
		DLZ-S30-PN	Light-ON	PNP open collector
		DLZ-S30D-PN	Dark-ON	

Activation area characteristics(Typical Example)

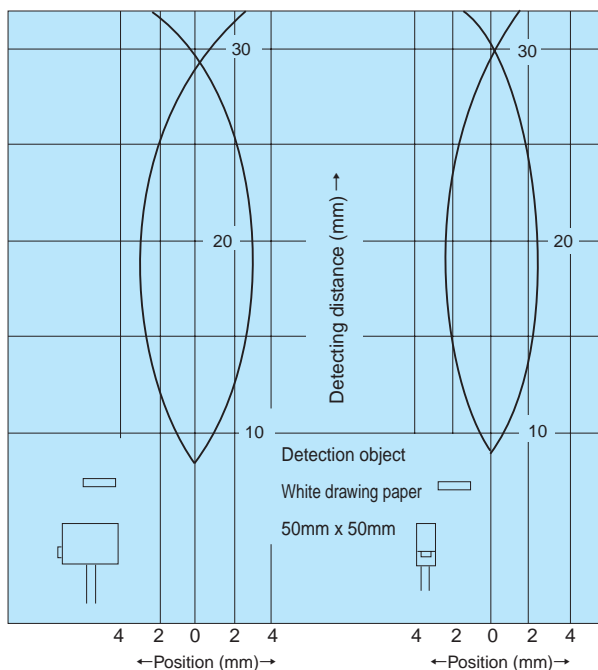

This product is a reflective type sensor and the detecting distance varies depending on the detection object. To install the sensor first check the distance using the object to confirm.

Sample Applications

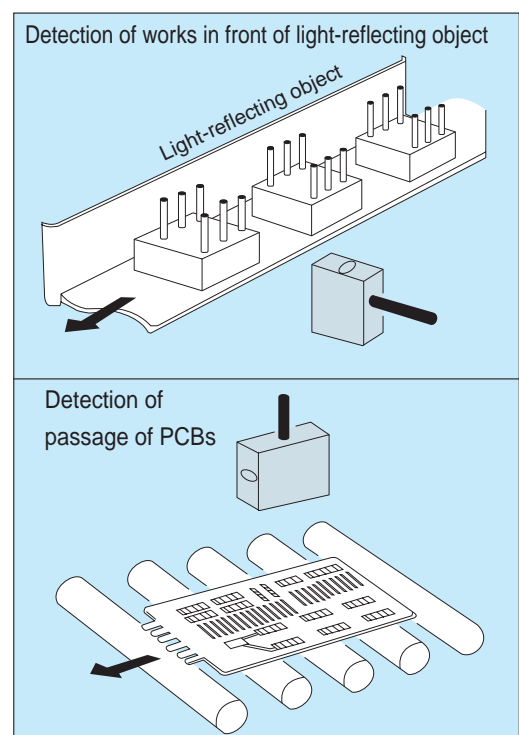

Rating/Performance/Specification

Model		DLZ-S30	DLZ-S30D	DLZ-S30-PN	DLZ-S30D-PN	
Rating/performance	Detection method	Limited reflection type (specular reflection)				
	Detecting distance	About 30mm (50 x 50 mm white drawing paper)				
	Detection object	φ 10 max.				
	Power supply	12 - 24V DC ±10% / Ripple 10% max.				
	Current consumption	30mA max.				
	Output mode	NPN open collector		PNP open collector		
	Rating	Sink current 100 mA (30 VDC) max.		Source current 100 mA (30 VDC) max.		
	Operation mode	Light-ON	Dark-ON	Light-ON	Dark-ON	
	Response time	0.5ms max.				
	Hysteresis	2% max.				
Specification	Light source	Infrared LED (wavelength: 880 nm)				
	Indicator	Operation indicator (red LED)				
	Short circuit protection	Provided				
	Material	Case	Polyarylate			
		Lens	Polycarbonate			
	Connection	Permanently attached cord (outer dimension: dia. 4) 0.2 sq. 3 core 2 m length				
	Mass	About 70 g				
	Ambient light	5,000 lx max.				
	Ambient temperature	-25 - +55°C (non-freezing)				
	Ambient humidity	35 - 85%RH (non-condensing)				
Protective structure	IP65					

Input/Output Circuit and Connection

Dimensions (in mm)

(NPN output)

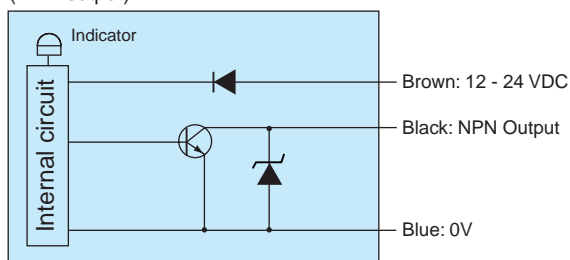

(PNP output)

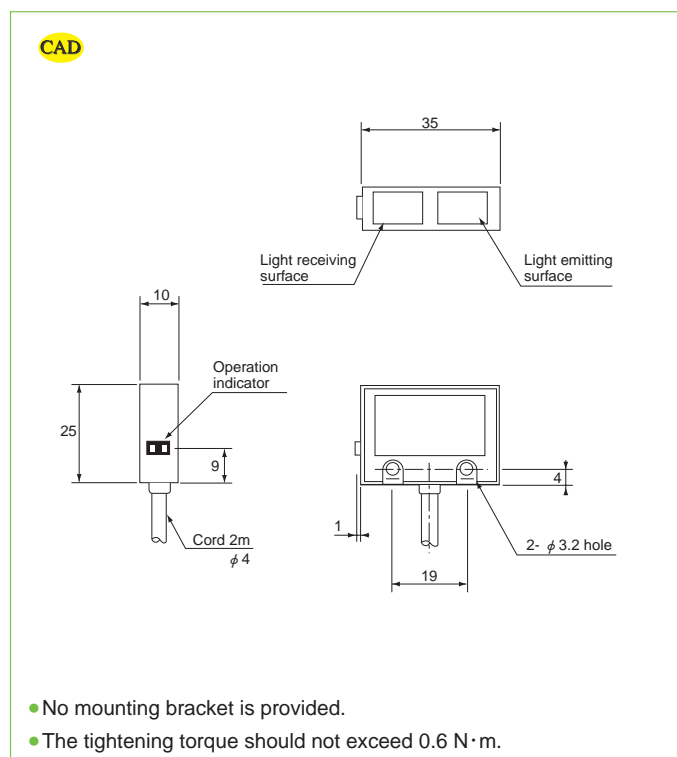
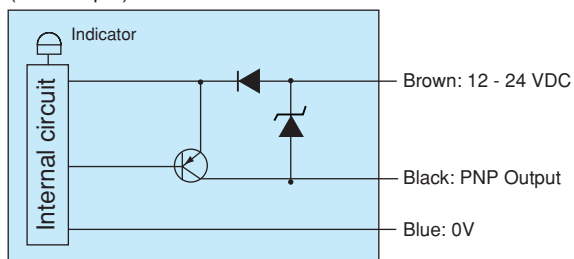

- The output transistor turns off when load short circuit or overload occurs.
Check the load and turn the power back on.



- Equipped with inverter light suppression circuit
- Perforated objects reliably detected with large-diameter light spot (GM-S Series)

Applications

- Lead frame detection
- PDB detection
- Board detection

Type

Detection method	Detecting distance	Model		Operation mode	Output mode
		NPN type	PNP type		
Wide-angle diffuse-reflective type	50mm	GM-S5RT(-J)	GM-S5RTPN(-J)	Light-ON	Open collector
Limited zone-reflective type		GM-Z5RT(-J)	GM-Z5RTPN(-J)		

Optional Parts

Type	Model	Shape
Cord with M8 connector	FBC-4R2S	Straight (2 m)
	FBC-4R2L	Angled (2 m)

M8 connector type (-J)



Directional characteristics (Typical Example)

• GM-S5RT

• GM-Z5RT

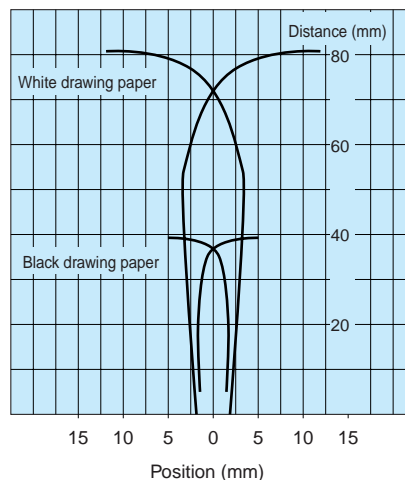
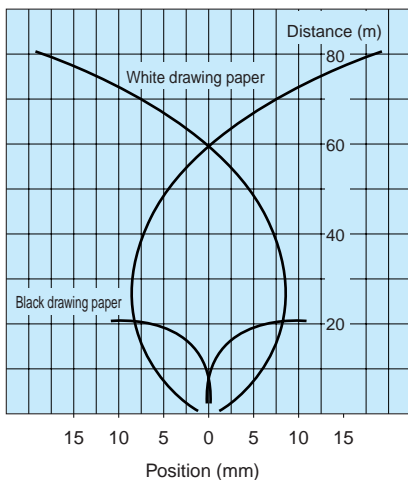

Rating/Performance/Specification

Model	NPN type	GM-S5RT	GM-Z5RT
	PNP type	GM-S5RTPN	GM-Z5RTPN
Rating/performance	Detection method	Wide-angle diffuse-reflective type	Limited zone-reflective type
	Detecting distance	50mm (Standard detecting object: 100 x 100 mm white drawing paper)	50mm (Standard detecting object: 50 x 50 mm white drawing paper)
	Power supply	12-24V DC $\pm 10\%$ / Ripple 10% max.	
	Current consumption	32mA max.	30mA max.
	Emitted light spot diameter	About 20 mm (at 20 mm)	About 4 mm (at 20 mm)
	Control output	Open collector output	
	Rating	NPN type: Sink current 100 mA (30 VDC) max. / Residual voltage: 1 V or less PNP type: Sink current 100 mA (30 VDC) max. / Residual voltage: 1 V or less	
	Operation mode	Light-ON	
	Response time	1ms max	
	Light source	Red LED (644nm)	
Rating / Performance	Indicator	Operation indicator (orange LED)	Stability indicator (green LED)
	Volume	SENS: sensitivity adjustment volume	
	Short circuit protection	Provided	
	Connection	Permanently attached cord (outer dimension: dia. 3.9mm) 0.2 sq. 3 core 2 m length Connector type with M8 connector (-J at the end of model No.)	
	Mass	About 50g (permanently attached cord)	About 10g (M8 connector type)
	Accessory	Screwdriver for adjustment, operation manual	

Environmental Specification

Environment	Ambient light	5,000 lx max.
	Ambient temperature	-25 - +55 °C (non-freezing)
	Ambient humidity	35-85%RH (non-condensing)
	Protective structure	IP67
	Vibration	10-55 Hz / 1.5 mm amplitude / 2 hours each in 3 direction
	Shock	500 m/s ² / 3 times each in 3 directions
	Dielectric withstanding	1,000 VAC for 1 minute
	Insulation resistance	500 VDC, 20 M Ω or higher

Dimensions (in mm)

Permanently attached cord	M8 connector type (-J)

Input/Output Circuit and Connection

(NPN output)

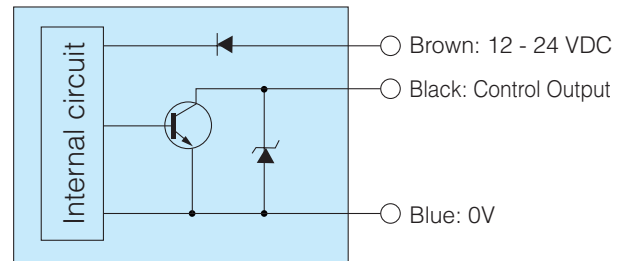

(PNP output)

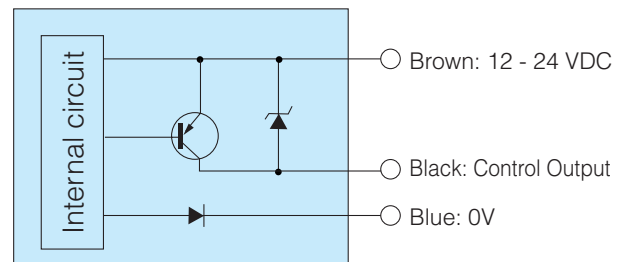

- The output transistor turns off when load short circuits or an overload occurs.
Check the load and turn the power back on.

M8 connector type (-J) connection

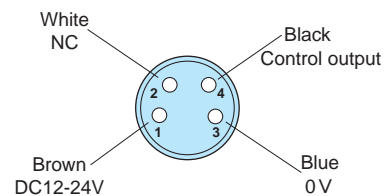

- The colors show lead colors for use in combination with the optional cord with M8 connector.
- White line (NC) is unused.



Ultra thin beam and high power are achieved at the same time

LD-M10R (polarization reflector type)

- Ultra thin laser beam is ideal for detecting minute objects
- Long distance detection up to 15 m is possible (with K-7 reflector)
- Various reflectors available for different detecting distances

LD-S20R (diffuse-reflective)



- Variable-focus spot adjustable down to $\phi 1$
(In the range of 80-300 mm from light receiving surface)
- Red laser for simple position checking of emitted light spot
 - Extra thin laser beam ideal for detection of passage/presence or protrusion of minute objects through gap or small hole

Warning Laser beam employed



Do not look into the beam, do not direct light to human body and follow all instructions for correct and safe use.

Type

Detection method	Detecting distance	Model	Operation mode	Output mode
 Polarization reflector type	The detecting distance depends on the reflector used.	LD-M10R	Light-ON/ Dark-ON selectable (with switch)	NPN open collector
		LD-M10RPN		PNP open collector
 Diffuse-reflective type	 80~300mm	LD-S20R		NPN open collector
		LD-S20RPN		PNP open collector

Optional Parts

Product name	Model	Detecting distance(m)	Effective reflecting surface (mm)	Purpose/application
Reflector	K-15	0.3~7	36×55	For minute object detection
	S-0503A	0.5~7	24×24	For minute object detection
	K-72	1~5	29×8	For minute object detection
	K-MT4	1~7	35×35	For minute object detection
	K-71	3~5	32×19	When there is restriction to mounting of reflector
	K-7	3~15	56×36	For long distance detection

■ Select according to the detecting distance of the application and purpose (separately available).

Note that reflectors other than mentioned above may not be compatible with the sensor.

Rating/Performance/Specification

	Type	NPN output type	PNP output type	NPN output type	PNP output type
	Model	LD-M10R	LD-M10RPN	LD-S20R	LD-S20RPN
Rating/performance	Detection method	Polarization reflector type		Variable-focus reflective type	
	Spot variable range	—————		80mm - 300mm *3	
	Detecting distance	Depending on reflector (separately available)		30-300mm (10 x 10 mm white drawing paper) *3	
	Power supply	12-24V DC ±10% / Ripple 10% max.			
	Current consumption	35mA max. *1	40mA max. *1	35mA max. *1	40mA max. *1
	Output mode	NPN open collector output Sink current 100 mA (30 VDC) max.	PNP open collector output Source current 100 mA (30 VDC) max.	NPN open collector output Sink current 100 mA (30 VDC) max.	PNP open collector output Source current 100 mA (30 VDC) max.
	Operation mode	Light-ON/Dark-ON selectable			
	Anti Interference	Provided			
	Light Emission Stop Function	No-voltage input (contact/non-contact)			
	Response time	0.5ms max.			
	Spot diameter	15 x 7 mm ellipse (at 15 m)		φ 1mm(adjustable range: 80-300 mm from light receiving surface)	
	Smallest detectable mark width	—————		1 mm (black mark on white background) at 300 mm	
	Specification	Light source (wavelength)	Red semiconductor laser (650 nm) Class 2		
Indicator		Operation indicator (red LED)		Stability indicator (green LED)	
Volume		SENS: sensitivity adjustment			
Switch		Light-ON/Dark-ON selector switch provided			
Short circuit protection		Provided			
Connection		Permanently attached cord (outer dimension: dia. 4) 0.2 sq. 4 core 2 m length (black)			
Material		Case: heat-resistant ABS	Lens: Acrylic	Case: heat-resistant ABS	Transmitter lens: glass / Transmitter hood: aluminum / Receiver lens: acrylic
Mass		Approx. 80g			
Accessory		Operation manual, mounting bracket, screwdriver for sensitivity adjustment, warning label, instruction label *2			

*1 Allow sufficient margin in the capacity of the power supply (the laser diode is equipped with a circuit that maintains the same light intensity level by increasing the current if it becomes dark).

*2 The LD-M10 R Series is not provided with a reflector, which is optional.

*3 Distance from the sensor receiving lens surface.

Environmental Specification

Environment	Ambient light	5,000 lx max.
	Ambient temperature	-10 - +55°C (non-freezing)
	Ambient humidity	35 - 85%RH (non-condensing)
	Protective structure	LD-M Series: IP67 LD-S Series: IP66
	Vibration	10 - 55 Hz / 1.5 mm amplitude / 2 hours each in 3 direction
	Shock	LD-M series: 500 m/s ² / 3 times each in 3 directions LD-S series: 300 m/s ² / 3 times each in 3 directions
	Dielectric withstanding	1,000 VAC for 1 minute
	Insulation resistance	500 VDC, 20 MΩ or higher

Input/Output Circuit and Connection

● NPN output

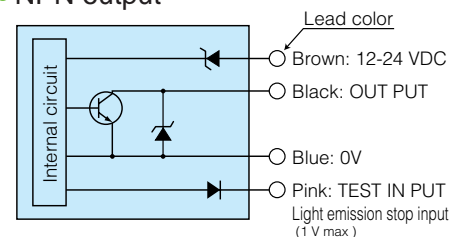

● PNP output

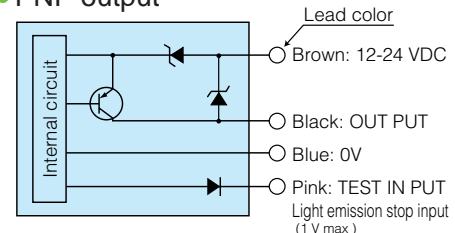

● Slow starter circuit is provided for laser emission.

The laser light is illuminated about 1 second after power-up or reset of short circuit caused by emission stop input.

● The output transistor turns off when load short circuit or overload occurs. Check the load and turn the power back on.

Panel Indication

- **Operation indicator (OP.L)**
Red LED illuminated when output transistor is turned on.
- **Stability indicator (STB.)**
Green LED illuminated when received light intensity is less than 80% and more than 120 % of operation level.
- **Sensitivity adjustment volume (SENS.)**
Turning clockwise increases the sensitivity and counterclockwise decreases the sensitivity.
- **Light-ON/Dark-ON selector switch**
Setting the switch to L.ON (Light-ON) activates the output when a certain amount of light is detected. Turning the switch to D.ON (Dark-ON) activates the output when a certain amount of light is not detected.

About indicators

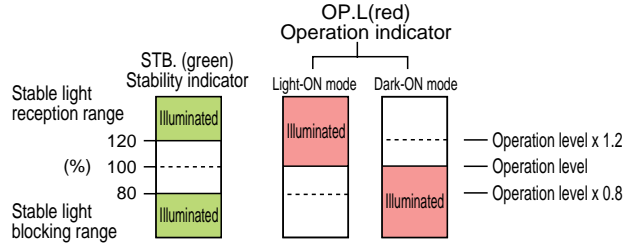

- The operation indicator (red LED) and stability indicator (green LED) indicate the levels as shown above. After light axis alignment and sensitivity adjustment have been completed, repeat activation and deactivation to make sure that the sensitivity is in the stable activation/deactivation range.
- Setting within the stable range increases the reliability against variation of environment after setting.

Using Light Emission Stop Function

- Short-circuiting TEST IN PUT (pink) and 0 V (blue) stops the laser light emission at arbitrary timing. When not using the light emission stop function, connect TEST INPUT (pink) to the positive terminal of the power supply (brown).

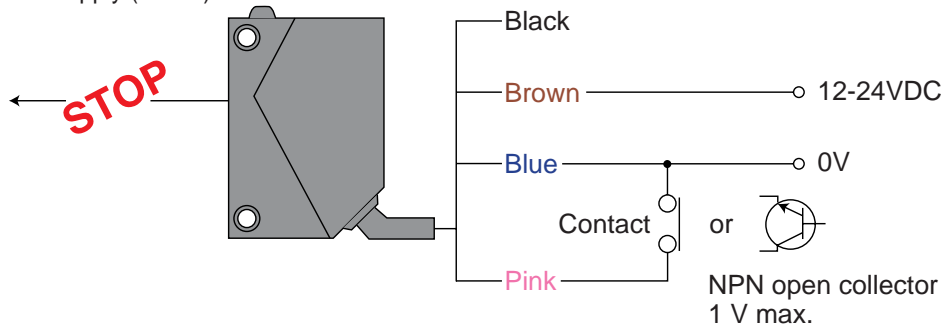

For Correct Use

- Do not use the product for detection for the protection of human body.
- When using the product for safety purposes, ensure safety with the control system as a whole as well as the detection.
- This product is not explosion proof.

- The semiconductor laser used in this product falls under the following class as defined in JIS C 6802 "Safety of Laser Products."
 - Class 2 (Emits visible radiation from which the eyes are generally protected by the aversion reactions)
- This product employs a parallel beam of laser and care should be taken not to allow the laser light to enter human eye directly or by specular reflection. Never look into the laser radiation outlet of the transmitter connected to power supply. Looking straight into the laser light may damage the eye.
- This product is provided with warning and instruction labels as shown below for notifying and alerting the operator of the sensor of the degree of danger. After the product has been installed, attach the labels in prominent locations on the sensor.

- The radiated laser beam is elliptic due to the characteristics of semiconductor laser. In addition, diffraction pattern is generated due to optical diffraction phenomenon.



- Be notified that this product uses semiconductor laser and is prone to deterioration due to surge current or static electricity.
- The laser diode is equipped with a circuit that maintains the same light intensity level by increasing the current if it becomes dark. For this reason, allow sufficient margin in the capacity of the power supply.
- Always avoid use in which the power is turned on and off consecutively.
- Be sure to turn off the power before moving including mounting and removing or repairing.
- Follow the notes on safety and handling in the operation manual provided for correct use.

Warning label



Instruction level

● Class 2

Laser beam
 Do not look into beam
 Max. max. output: 3 mW Pulse width: 3 μsec Light source: semiconductor laser
 Class 2 laser product

Sample Applications

LD-M10R Series

Detection of position of vehicle in multilevel parking garage

Checks for any protrusion of vehicle in multilevel parking garage.

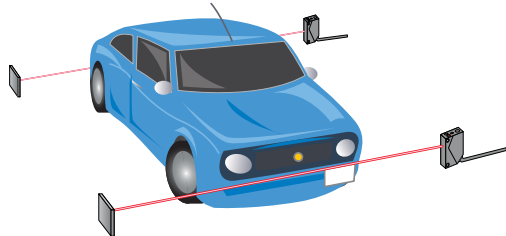

Detection of displaced cassettes

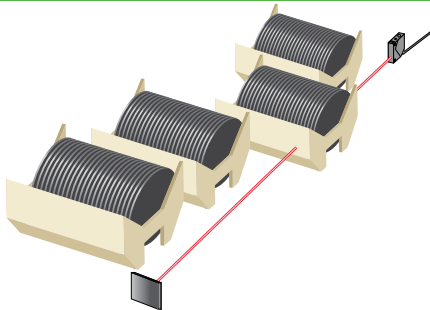

Setting/adjustment

- 1) Arrange the sensor face-to-face and in line with the reflector. Swivel the sensor vertically and horizontally with reference to the reflector, use the operation indicator (red LED) to check the area in which the sensor is activated and install the sensor at the center of the area. Make sure that the stability indicator (green LED) is illuminated.
- 2) Use the sensitivity adjustment volume for fine-tuning when detecting thin rod-like or small objects.

(Note)

Light reflected on the object may be detected depending on the object such as glossy detection objects including stainless steel. In this case, use the sensitivity adjustment volume to prevent detection of light from the object.

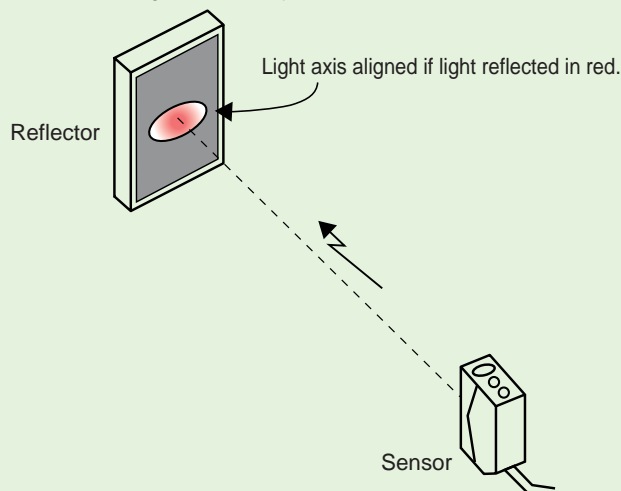

LD-S20R Series

Positioning of hybrid boards

High-precision positioning achieved with micro-spot laser beam.

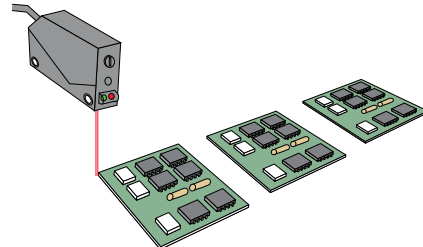

Detection of marks on corrugated cardboard boxes through narrow gap

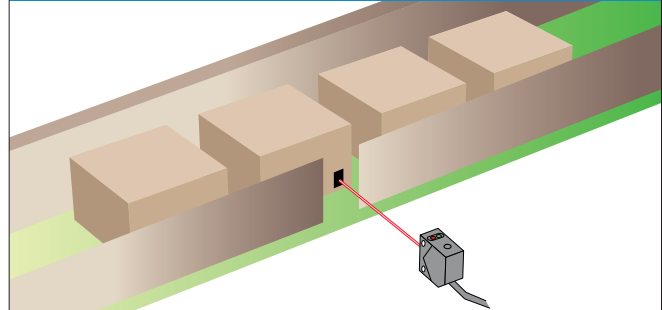

Spot position adjustment for variable-focus type sensor

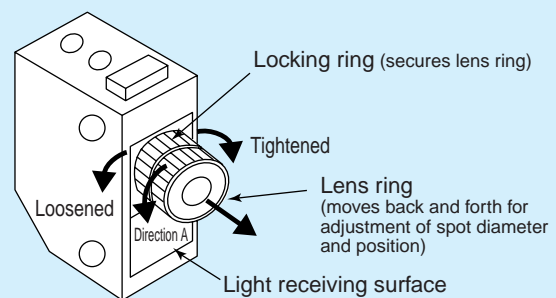

- The spot position is variable between 80 and 300 mm from the light receiving surface.
- The factory setting makes the spot diameter smallest at 300 mm from the light receiving surface. For adjusting the spot position, make sure that there is no obstacle especially in front of the receiver lens and follow the procedure below:

- 1) For viewing the spot, place a white piece of paper in front of the detection object. (Never look into the laser radiation outlet.)
- 2) (With the locking ring tightened,) turn the lens ring for adjusting the spot diameter and position while monitoring the spot on the white paper. In the figure above, turning in the direction A brings the spot position closer to the sensor. The lens ring is designed to require a certain amount of force to turn for preventing loosening, which may be felt when turning the lens.
- 3) When adjusting for a short distance, loosen the locking ring a little, make adjustment as described above and securely tighten the locking ring.
- 4) After the adjustment, mount and secure the sensor body again.

Characteristics (Typical Example)

LD-M10R series
Directional characteristics 25

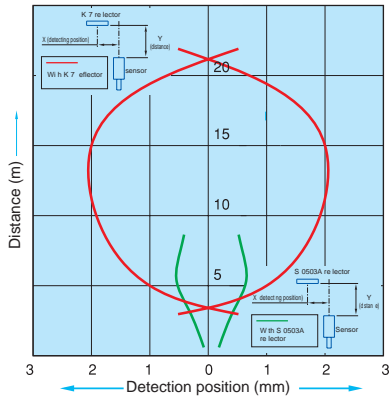

LD-M10R series
Distance-output characteristics With K-7 reflector

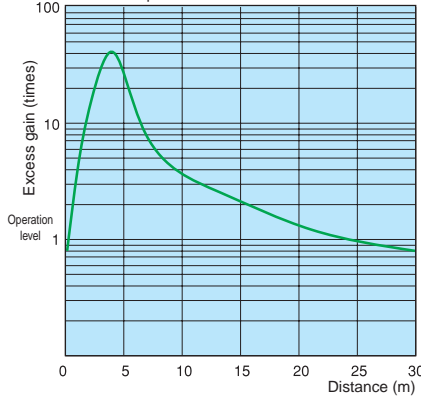

LD-M10R series
Pattern diameter 20

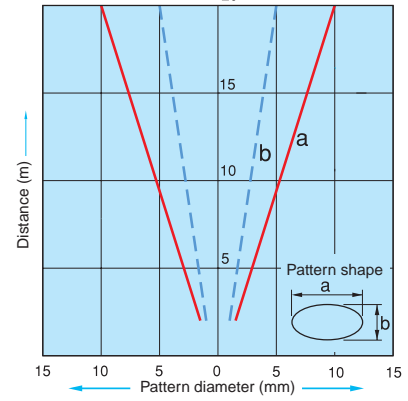

LD-M10R series
Operating angle characteristics With K-7 reflector

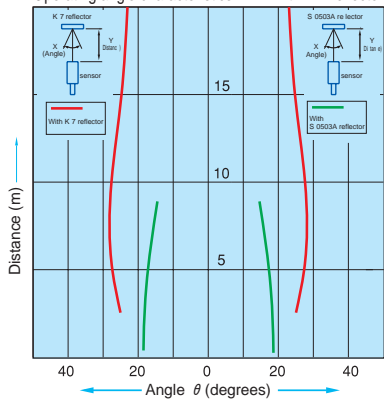

LD-S20R series
Directional characteristics 400

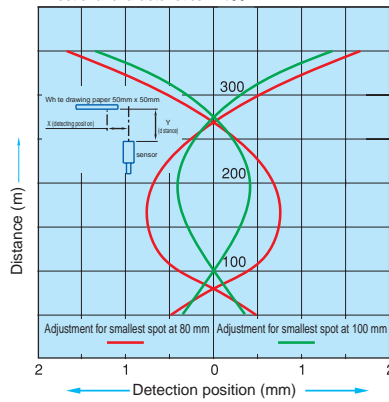

LD-S20R series
Directional characteristics 400

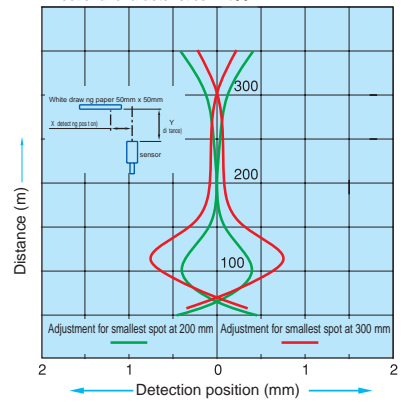

LD-S20R series
Distance-output characteristics White drawing paper 50 x 50

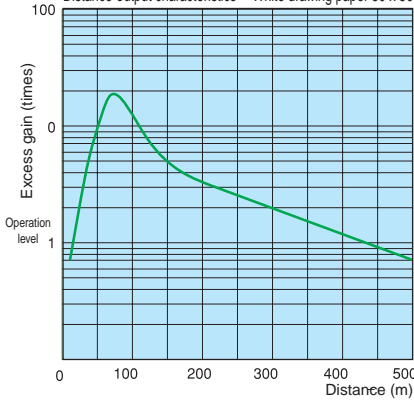

LD-S20R series
Pattern diameter Adjustment for smallest spot diameter at 80 mm

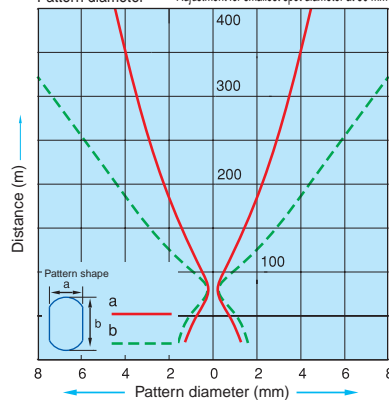

LD-S20R series
Pattern diameter Adjustment for smallest spot diameter at 100 mm

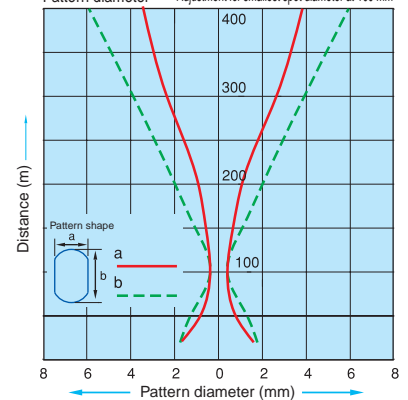

LD-S20R series
Pattern diameter Adjustment for smallest spot diameter at 200 mm

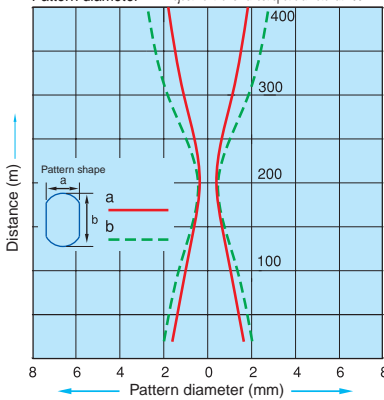

LD-S20R series
Pattern diameter Adjustment for smallest spot diameter at 300 mm

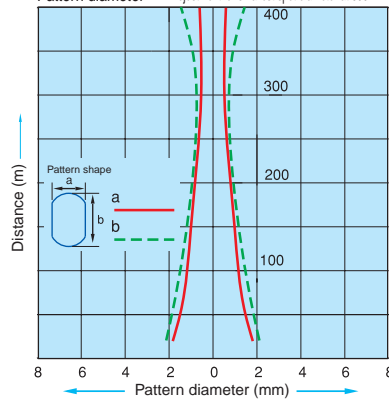

LD-M10R series LD-S20R series
Temperature characteristics (LD-S20R (PN) LD-M10R (PN))

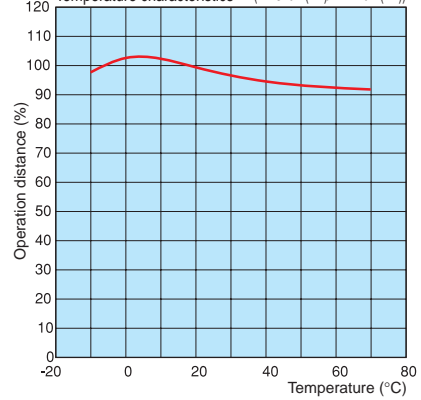

Dimensions (in mm)

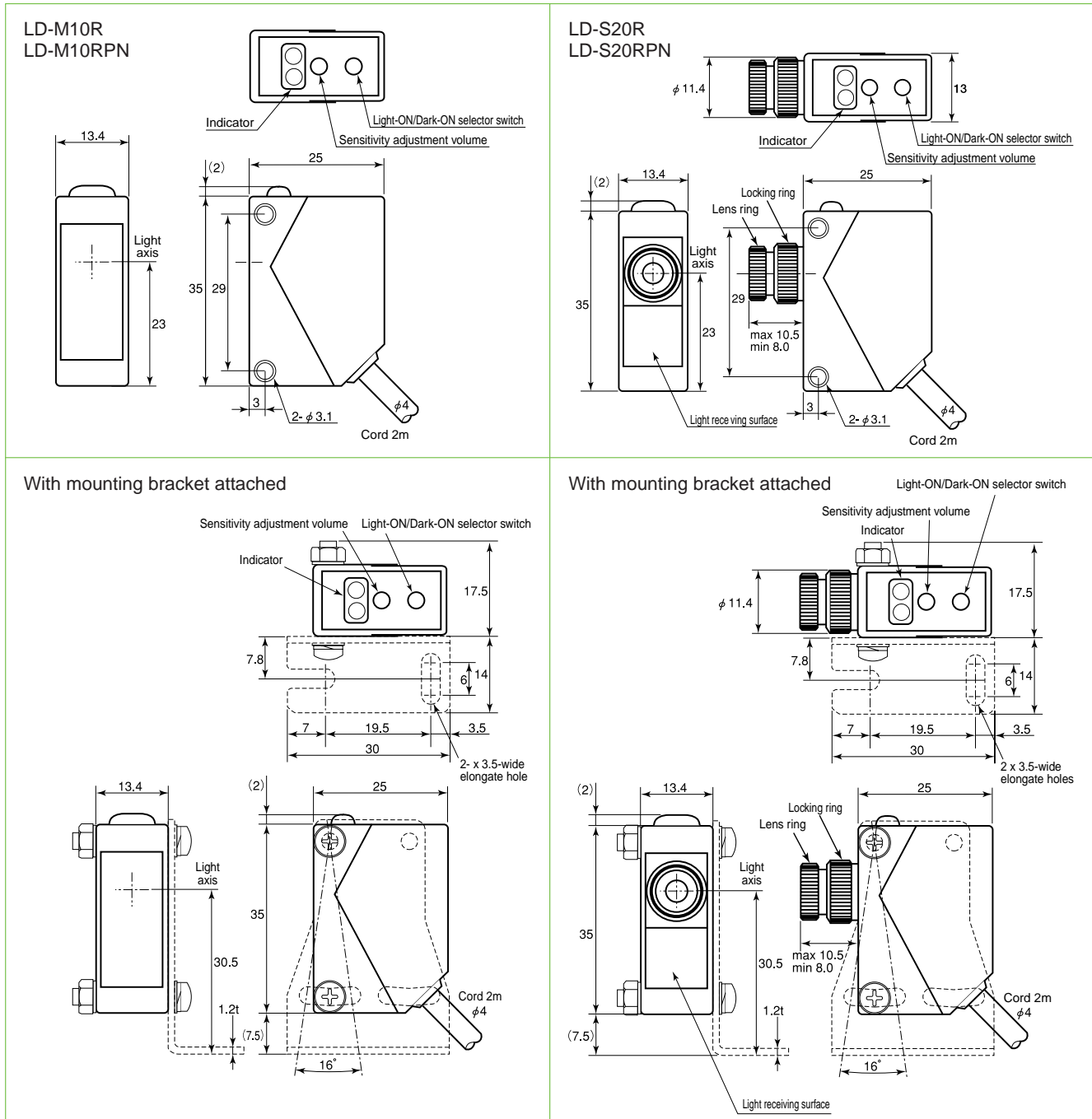

Optional Parts (in mm)

Reflector model	K-7	K-15	K-MT4	K-71	K-72	S-0503A
Detecting distance	3~15m	0.3~7m	1~7m	3~5m	1~5m	0.5~7m
Effective reflecting surface	56×36mm	36×55mm	35×35mm	32×19mm	29×8mm	24×24mm
Dimensions (in mm)						

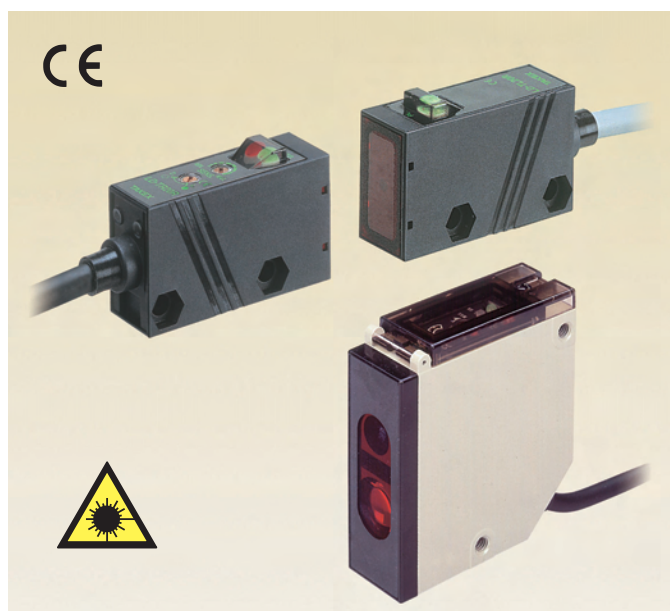

- Thin red laser beam allows highly-accurate detection









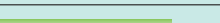

- Minute object detected at long distance
- Wide variety of models for different detecting distances and detection objects
- Simple adjustment with red spot
- Class 1 and 2 models available

- Reflective type (LD-S33R)

- 0.5 mm mark detected at long distance of 300 mm
- Small-field beam allowing detection through gaps and small holes
- Light emission stop function provided

Take safety measures according to the operation manual.

Type

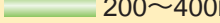
Detection method	Detecting distance	Model	Detection object	Operation mode	Output mode
 Through-beam type	 20m	LD-T20R	Opaque objects of $\phi 20$ mm or larger	Light-ON/ Dark-ON selectable (with switch)	Open collector
	 15m	LD-T20R-P2	Opaque objects of $\phi 2$ mm or larger		
	 7m	LD-T20R-P1	Opaque objects of $\phi 1$ mm or larger		
	 3m	LD-T20R-P05	Opaque objects of $\phi 0.5$ mm or larger		
	 0.7m	LD-T20R-P03	Opaque objects of $_0.3$ mm or larger		
	 20m	LD-T20R-C1	Opaque objects of $_20$ mm or larger		
	 10m	LD-T20R-C1-P2	Opaque objects of $_2$ mm or larger		
	 5m	LD-T20R-C1-P1	Opaque objects of $_1$ mm or larger		
 Limited reflection type	 200~400mm	LD-S33R	0.5mm min. (black mark on white background) Detecting distance 300mm		NPN open collector output

- PNP output type

PNP output types are available for all models.

PNP output type models are identified by "PN" at the end of model number.

The rating/performance other than the output is the same as those of NPN types.

Optional parts

Type	Model	Applicable model	Shape, etc.
Cord with M8 connector	FBC-4R2S	For M8 connector type	Straight with 4-core cord of 2 m (transmitter/receiver)
	FBC-4R2L		Angled with 4-core cord of 2 m (transmitter/receiver)
Protective cover	G-MTB2	For through-beam LD-T20R	Rigid protective cover doubling as mounting bracket. See "Dimensions (optional parts)."

Rating/Performance/Specification

Model	NPN type	LD-T20R	LD-T20R-C1	LD-S33R
	PNP type	LD-T20RPN	LD-T20RPN-C1	—————
Detection method		Through-beam type		Limited reflection type
Power supply		12 - 24V DC \pm 10% / Ripple 10% max.		
Current consumption	NPN type	Transmitter: 20 mA max. Receiver: 20 mA max.		38mA以下
	PNP type	Transmitter: 20 mA max. Receiver: 25 mA max.		—————
Output mode	Control output	NPN open collector output Rating: sink current 100 mA (30 VDC) max.		NPN open collector 2 outputs Rating: sink current 100 mA (30 VDC) max.
		PNP open collector output Rating: source current 100 mA (30 VDC) max.		
	Stability output	NPN open collector output Rating: sink current 50 mA (30 VDC) max.		—————
PNP open collector output Rating: source current 50 mA (30 VDC) max.		—————		
Operation mode		Light-ON/Dark-ON selectable		
Response time		0.5ms max.		
Operating angle		30° (at receiver)		—————
Spot diameter		—————		About 2 mm at 300 mm
Smallest detectable mark width		—————		0.5 mm (black mark on white background) at 300 mm
Light source (light wavelength)		Red semiconductor laser (650 nm) Class 2	Red semiconductor laser (650 nm) Class 1	Red semiconductor laser (650 nm) Class 2
Indicator		Transmitter: power indicator (green LED)		Operation indicator (red LED) Stability indicator (green LED)
		Receiver: operation indicator (red LED) Stability indicator (green LED)		
Volume		SENS: sensitivity adjustment (at receiver)		8-turn sensitivity adjustment
Switch		Light-ON/Dark-ON selector switch provided		
Short circuit protection		Provided (for control output only)		Provided
Material	Case	Polyarylate		Body: zinc die-cast / Aluminum head: heat-resistant ABS / Display: polycarbonate
	Lens	Acrylic		Glass
Connection		Permanently attached cord(outer dimension: dia. 4.2) Transmitter: 0.3 sq. 2 core 2 m length (gray) Receiver: 0.2 sq. 4 core 2 m length (black)		Permanently attached cord (outer dimension: dia. 4.5) 0.2 sq. 5 core 2 m length
		-J type: M8 connector connection		
Mass		Permanently attached cord type: about 80 g (transmitter/receiver) / -J type: about 25 g (transmitter/receiver)		Approx. 300g
Notes		Mounting bracket, operation manual, warning label, instruction label		

Environmental Specification

	LD-T20R	LD-S33R
Ambient light	5,000 lx max.	Sunlight: Light receiving surface illumination 10,000 max. Incandescent lamp: receiving surface illumination 3,000 lx max.
Ambient temperature	-10 - +55°C	
Ambient humidity	35 - 85%RH	
Protective structure	IP67	IP66
Vibration	10 - 55 Hz / 1.5 mm amplitude / 2 hours each in 3 direction	
Shock	500 m/s ² / 3 times each in 3 directions 100 m/s ² / 3 times each in 3 directions	
Dielectric withstanding	1,000 VAC for 1 minute	
Insulation resistance	500 VDC, 20 MΩ or higher	

- Applicable power supply unit
PS Series
High capacity of 200 mA at 12 VDC



- (General-purpose type) PS3N
PS3N-SR
- (Multifunctional type) PS3F
PS3F-SR

Input/Output Circuit and Connection

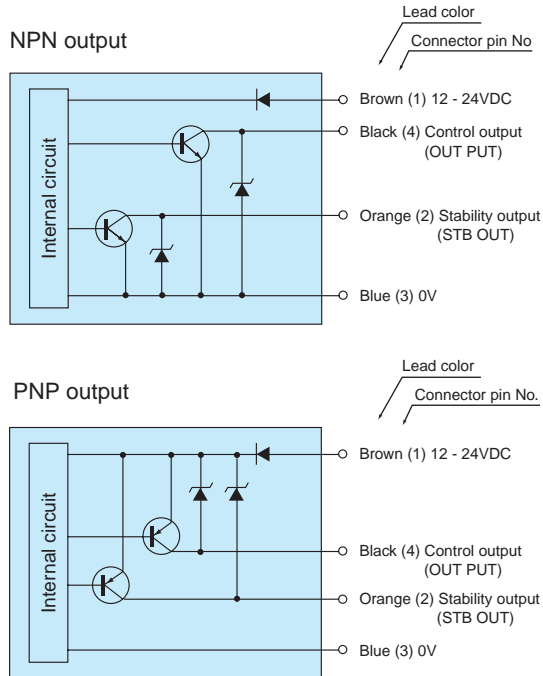

- The output transistor turns off when load short circuit or overload occurs. Check the load and turn the power back on.
- The stability output is not provided with short circuit protection.

Switching between Light-ON and Dark-ON

The operation mode selector switch is provided on the receiver.

Turn to L for Light-ON mode and D for Dark-ON mode.

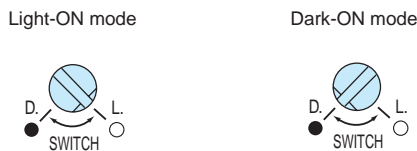

Characteristics (Typical Example)

Directional characteristics

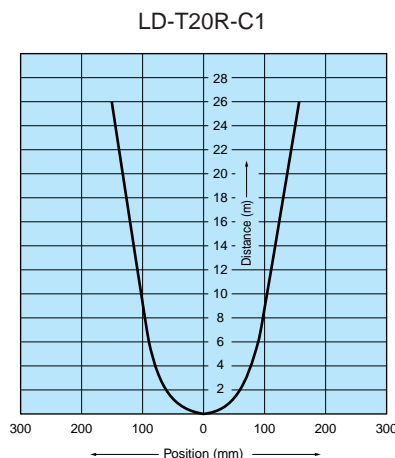
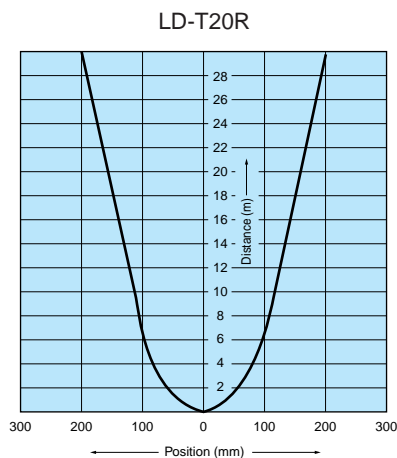

Temperature characteristics

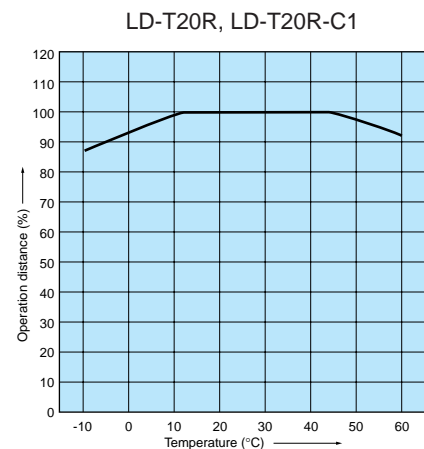

M8 connector type (-J)

Pin assignment

(Receiver)

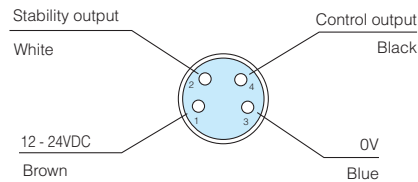

The colors show lead colors for use in combination with the optional cord with M8 connector.

(Transmitter)

Lines other than Lines 1 (brown) and 3 (blue) are unused.

Stability output

The stability output can be used to check for reduction of the light intensity level along with any change in the operating environment or operation over time or to perform initial check of the operation. When two consecutive detections have occurred with the intensity of light detected exceeding the operation level but not reaching 120 % of the level (range allowing stable operation), the stability signal is output when the control output is deactivated.

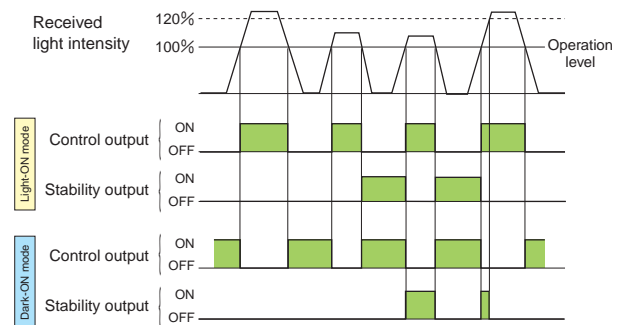

Panel Indication

LD-S33R

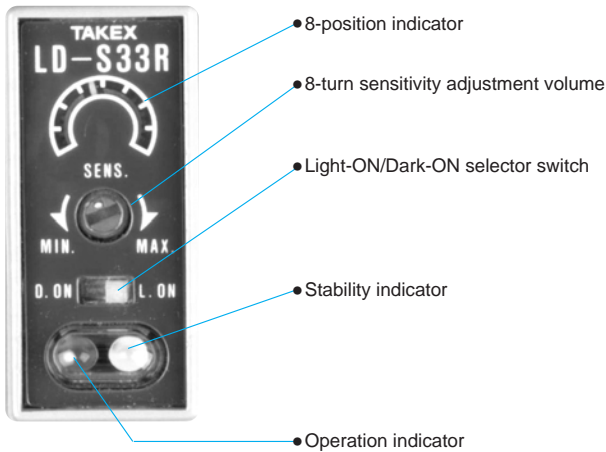

Input/Output Circuit and Connection

LD-S33R

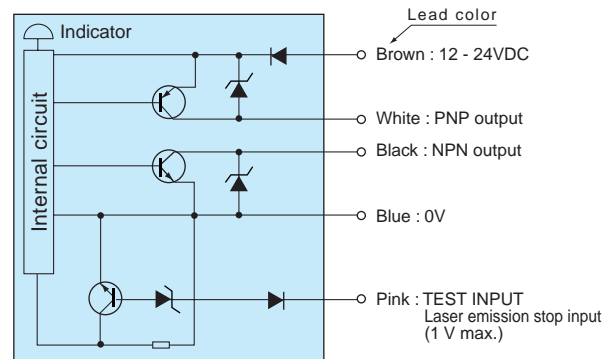

Slow starter circuit is provided for laser emission. The laser light is illuminated about 0.5 seconds after power-up or reset of short circuit caused by emission stop input.

The output transistor turns off when load short circuit or overload occurs. Check the load and turn the power back on.

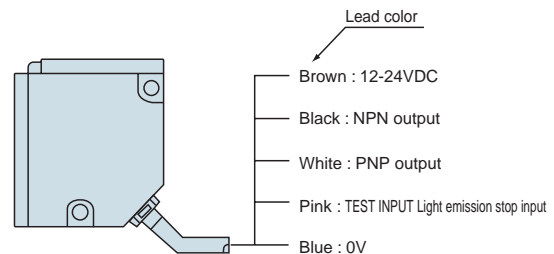

Using Light Emission Stop Function (LD-S33R only)

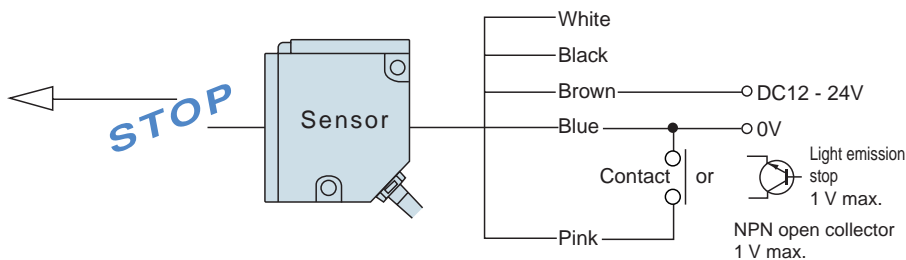

Short-circuiting the blue and pink leads of the transmitter stops the laser light emission at arbitrary timing.

Activation Area Characteristics (Typical Example)

LD-S33R

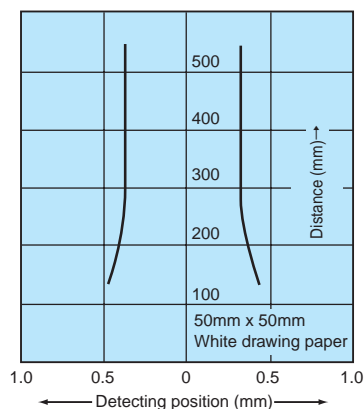

Sample Applications

Highly-accurate detection achieved with extra thin beam

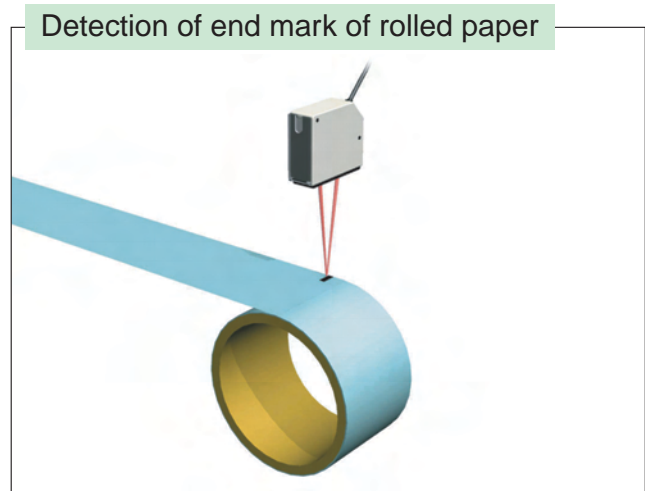
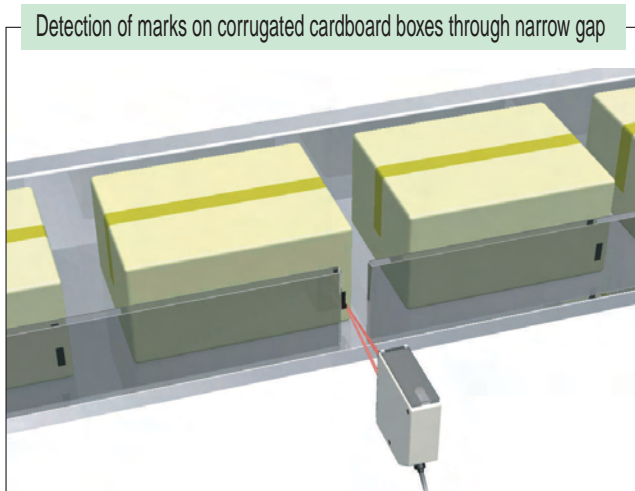
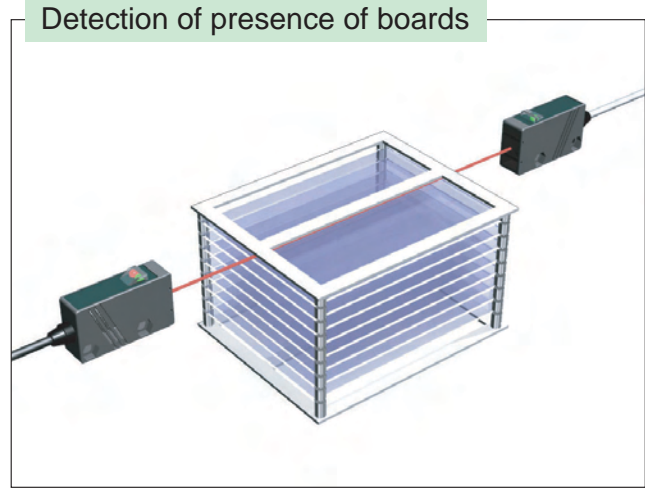
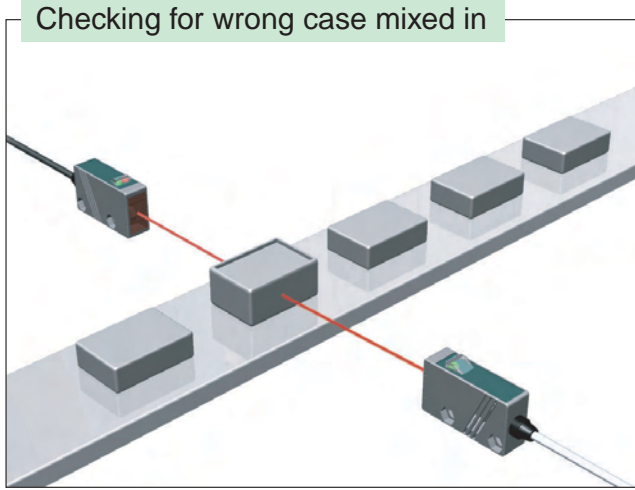

For Correct Use



- Do not use the product for for the protection of human body.
- When using the product for safety purposes, ensure "System-Wide" safety with the control system as a whole as well as the detection.
- This product is not explosion proof.

- The semiconductor laser used in this product falls under the following class as defined in JIS C 6802 "Safety of Laser Products."
 - Class 1 (Intrinsically safe under the rationally predictable operation conditions)
 - Class 2 (Emits visible radiation from which the eyes are generally protected by the aversion reactions)
- This product employs a parallel beam of laser and care should be taken not to allow the laser light to enter human eye. Never look into the laser radiation outlet of the transmitter connected to power supply. Looking straight into the laser light may damage the eye.
- This product is provided with warning and instruction labels as shown below for notifying and alerting the operator of the sensor of the degree of danger. After the product has been installed, attach the labels in prominent locations on the sensor.

- The radiated laser beam is elliptic due to the characteristics of semiconductor laser. In addition, diffraction pattern is generated due to optical diffraction phenomenon.

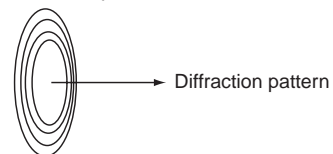

- Be notified that this product uses semiconductor laser and is prone to deterioration due to surge current or static electricity.
- The laser diode is equipped with a circuit that maintains the same light intensity level by increasing the current if it becomes dark. For this reason, allow sufficient margin in the capacity of the power supply.
- Always avoid use in which the power is turned on and off consecutively.
- Be sure to turn off the power before moving including mounting and removing or repairing.

Warning label



Instruction level

•Class 2

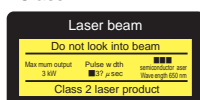

•Class 1.

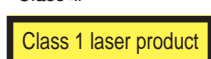

Dimensions (in mm)

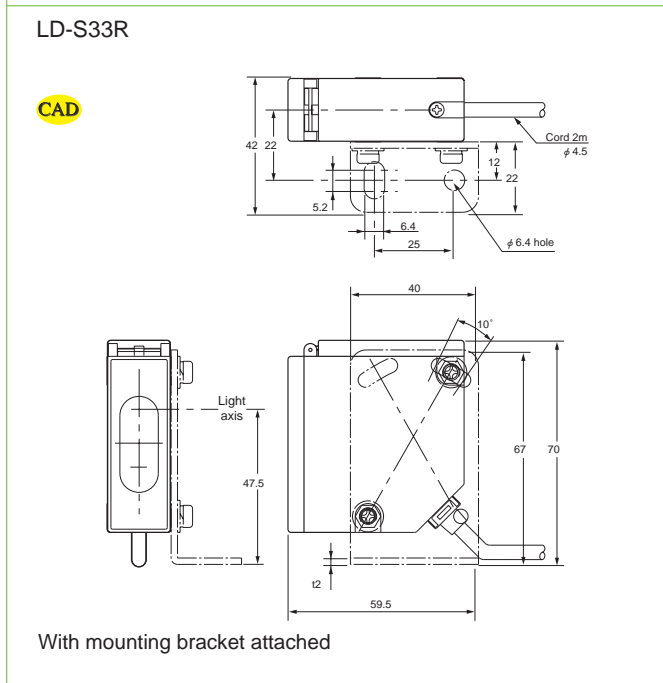
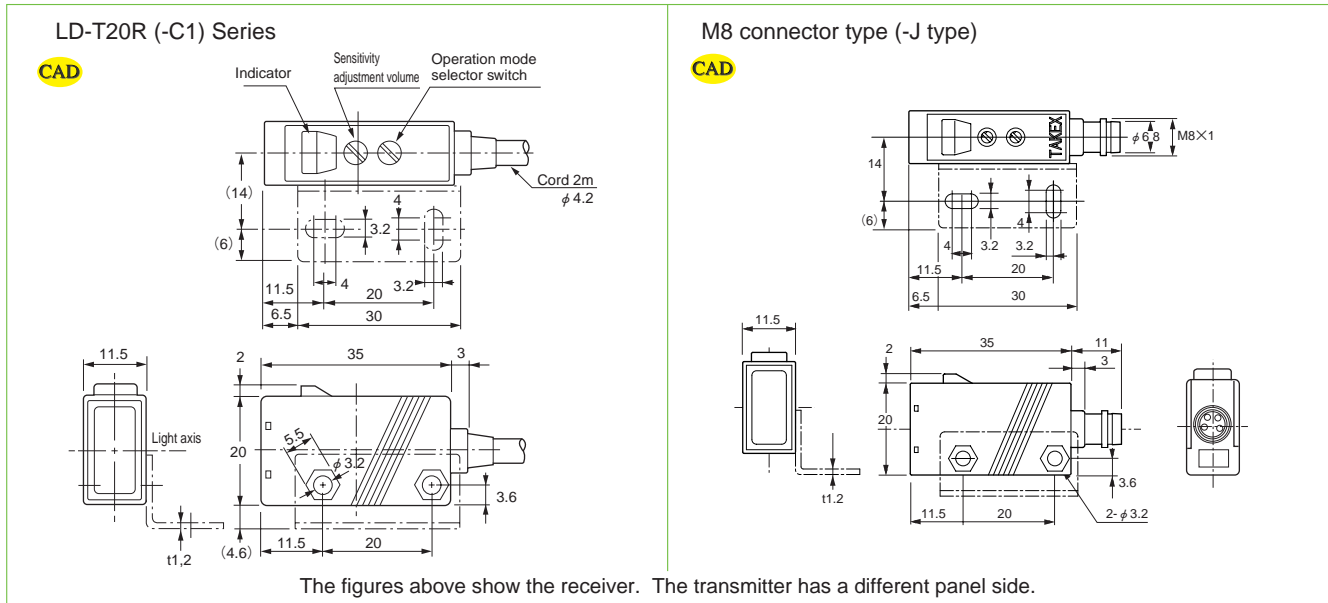

Dimensions (Optional parts) (in mm)

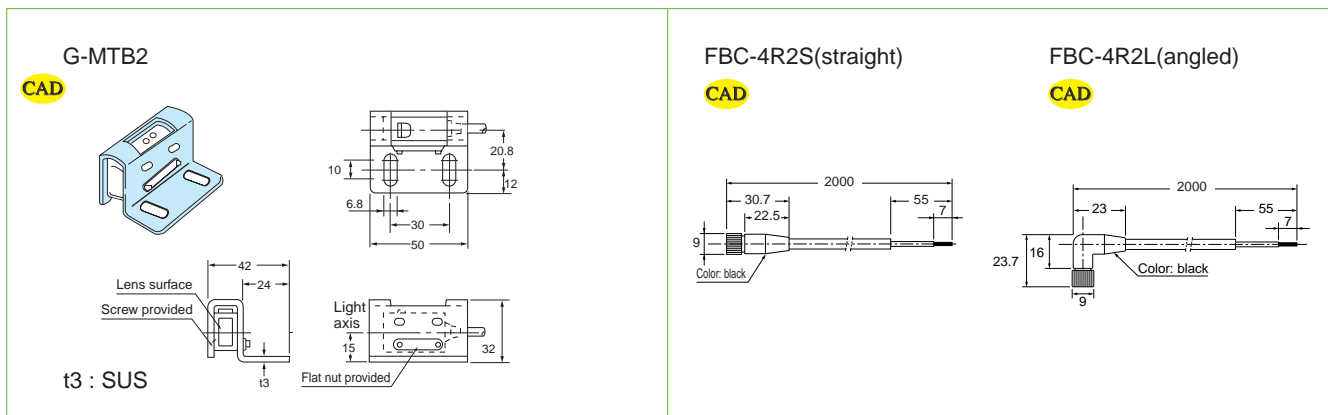

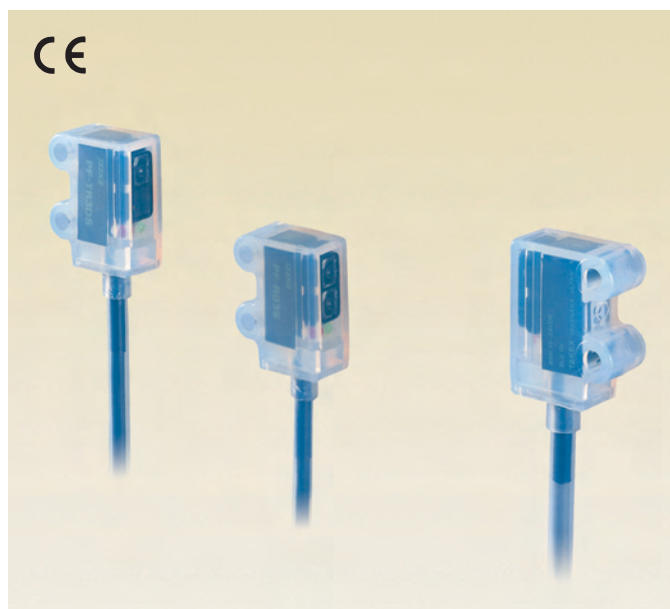

- Embedded amplifier sensor with body and cord covered with fluoroplastic (PFA) housing and tube for enhanced resistance to oils and chemicals.

Excellent resistance to oils and chemicals, capable of immersed use.

- Easy-to-use embedded amplifier sensor
- Long detecting distance (through-beam: 3 m; diffuse-reflective: 30 cm)
- High-speed response of 0.35 ms
- Optional external sensitivity adjustment employed

Type

Detection method	Detecting distance	Model	Operation mode	Output mode
 Through-beam type	 3m	PF-T3DS	Dark-ON	NPN open collector output
 Diffuse-reflective type	 300mm	PF-R03S	Light-ON	

• Red LED models

Red LED is used for light emitting element for resistance to underwater attenuation for detection of objects in water.

Model PF-T3RDS (through-beam)

Model PF-R03RS (reflective)

■ Indicators

- The operation indicator (red LED) and stability indicator (green LED) show the levels of light intensity as described in the figure below.
- After aligning the optical axis and adjusting the sensitivity, use a detection object to block and unblock the light beam several times to make sure that the sensitivity level is in a range that allows stable activation and deactivation.
- Setting the sensitivity in a range allowing stable operation achieves higher reliability against changes in the operating environment generated after the sensitivity is set.

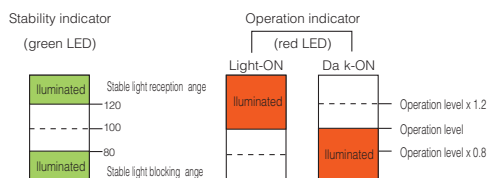

The red LED (OP.L) is the operation indicator. In the L.ON (Light-ON) mode, the indicator is illuminated when a certain amount of light is detected. In the D.ON (Dark-ON) mode, the indicator is illuminated when a certain amount of light is not detected.

■ Chemical resistance of PFA (fluoroplastic)

Substance	PFA	Substance	PFA
Bunker A, B, C heavy oil	○	Mineral oil	○
Aniline	○	Ethylene trichloride	○
Acrylic nitrile	○	Bichromate of soda	○
Asphalt	○	Barium nitrate	○
Acetone	○	Silicon oil	○
Alcohol	○	Vegetable oil	○
Ammonia	○	Thinner	○
Isooctane	○	Barium hydroxide	○
Isobutyl alcohol	○	Phenol	○
Isobutyl methyl ketone	○	Turbine oil	○
Ethanol (ethyl alcohol)	○	Sodium carbonate	○
Ether	○	Turpentine	○
Ethylene glycol	○	Natural volatile oil	○
Enamel paint	○	Kerosene	○
Ammonium chloride	○	Trichloroethane	○
Calcium chloride	○	Trichloroethylene	○
Sodium chloride	○	Toluene	○
Barium chloride	○	Naphtha	○
Chlorine	○	Lactic acid	○
Gasoline	○	Nitrobenzene	○
Glass raw material	○	Fluorine	×
Dilute hydrochloric acid	○	Ferrosilicon	○
Dilute caustic soda	○	Freon 11	○
Dilute acetic acid	○	Propyl alcohol	○
Dilute nitric acid	○	Propylene glycol	○
Dilute sulfuric acid	○	Benzene	○
Citric acid	○	Methanol (methyl alcohol)	○
Glycerin	○	Methyl violet	○
Cresol	○	Water	○
Chloroform	○	Carbon tetrachloride	○
Light oil	○	Ammonium sulfate	○

○ : applicable × : inapplicable

Rating/Performance/Specification

	Model	PF-T3DS	PF-R03S
Rating/performance	Detection method	Through-beam type	Diffuse-reflective type
	Detecting distance	3m	300mm
	Detection object	φ 20mm (Min.) Opaque	Standard detection object: 100 x 100 mm white drawing paper
	Power supply	12-24V DC ±10% / Ripple 10% max.	
	Current consumption	Transmitter: 12 mA max. Receiver: 15 mA max.	20mA max.
	Operation mode	Dark-ON(*1)	Light-ON(*2)
	Output mode	NPN open collector output Sink current 100 mA, 30 V DC max.	
	Response time	0.35ms max.	
	Hysteresis	—	10% max.
	Operating angle	10° (at receiver)	—
Specification	Light source (wavelength)	Infrared LED (880 nm)	
	Indicator	Transmitter: power indicator (red LED) Receiver: operation indicator (red LED) Stability indicator (green LED)	Operation indicator (red LED) Stability indicator (green LED)
	Volume	Not provided (optional: sensitivity adjustable with external volume)	
	Short circuit protection	Provided	
	Case material	PFA (fluoroplastic)	
	Connection	Permanently attached cord 3m length (2 m protected with PFA tube)	
		Transmitter: 0.15 sq. 2 core Receiver: 0.15 sq. 4 core	0.15 sq. 4 core
	Mass	About 100 g (transmitter/receiver)	About 100g
Notes			

*1 Model PF-T3S for Light-ON mode
*2 Model PF-R03DS for Dark-ON mode

- Applicable power supply unit
PS Series
High capacity of 200 mA at 12 VDC



(General-purpose type) PS3N
PS3N-SR
(Multifunctional type) PS3F
PS3F-SR

Environmental Specification

	Environment	
Ambient light		5,000 lx max.
Ambient temperature		-25 - +55°C (non-freezing/ non-condensing)
Protective structure		IP 67g (sensor body and cord up to 2 m from body) *
Vibration		10-55 Hz / 1.5 mm amplitude / 2 hours each in 3 direction
Shock		500 m/s ² / 3 times each in 3 directions
Dielectric withstanding		1,000 VAC for 1 minute
Insulation resistance		500 VDC, 20 MΩ or higher

*Indicates Class g oil resistance in addition to IEC Standard IP 67 protective structure.

Using In-line Volume Unit for PFA Sensor (optional)

In-line volume unit models provided with an operation mode selector switch, sensitivity adjustment volume and operation indicator are available for adjustment at a distant location.

• Specification

Model: PF-V2 (NPN output)
PF-V2PN (PNP output)
Power supply: 12~24V DC ±10% / Ripple 10% max.
Output mode: Open collector output
100 mA (30 VDC) max. / Residual voltage: 1 V max.
Response time: 0.3ms max.
Short circuit protection: Provided
Connection: permanently attached cord (2 m)
Sensor: φ 4 with four 0.2 mm² cores
Power/output: φ 4 with three 0.2 mm² cores
Case material: Polycarbonate
Mass: Approx. 150g

• Connection

Connect to the receiver of a through-beam sensor or reflective-type sensor.

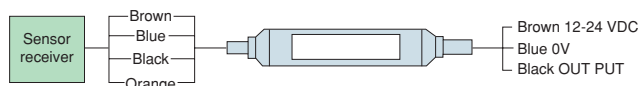

(Note) The volume unit and the cord are not covered with PFA (fluoroplastic) and should be used in normal atmosphere.

Input/Output Circuit and Connection

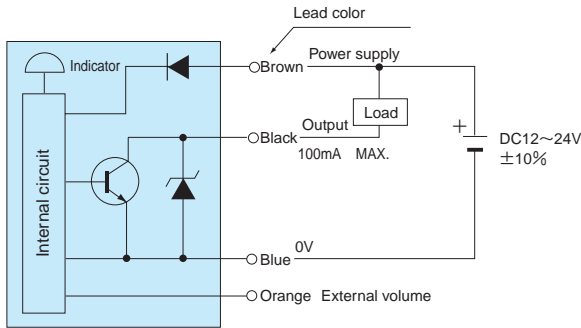

- The output transistor turns off when load short circuit or overload occurs. Check the load and turn the power back on.

Through-beam type transmitter

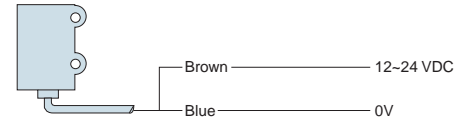

Through-beam type receiver and diffuse-reflective type

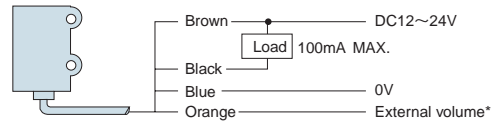

*Cut this lead off when not using the volume unit (model PF-V2) to leave it open and prevent it from touching other leads.

Directional characteristics(Typical Example)

PF-T3DS

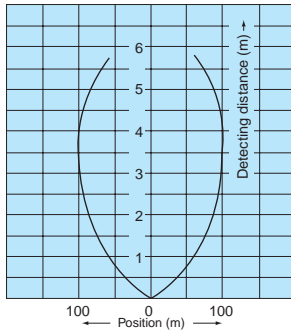

Activation area characteristics(Typical Example)

PF-R03S

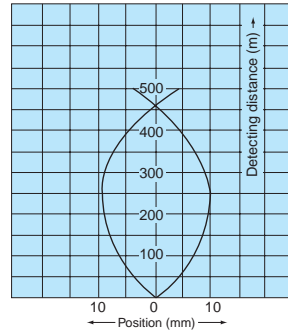

Distance-Output Characteristics (Typical Example)

PF-T3DS

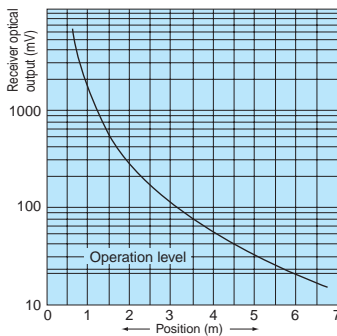

PF-R03S

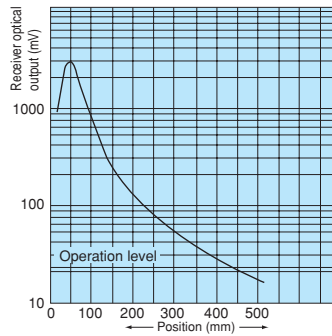

Hint on Handling (Reference Example)

- The sensor body and part of the cord is covered with PFA (fluoroplastic). A vinyl chloride cord extends out of the PFA tube (at 2 m from the sensor) and there is no sealing between the PFA tube and the cord. When using in chemical atmosphere, use the separately-available PFA joint, etc. in the partition wall between the chemical and normal atmospheres to route the cord.

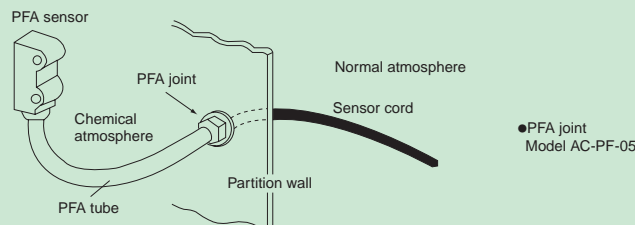

●PFA joint Model AC-PF-05

Dimensions (in mm)

PF-T3DS

CAD

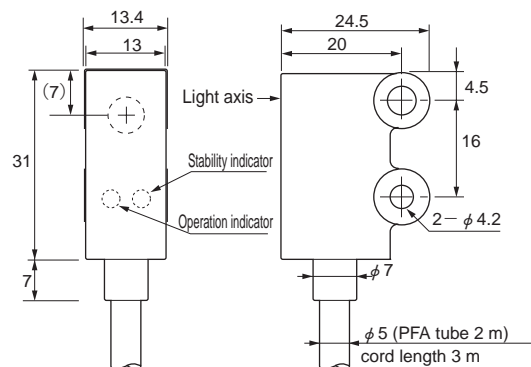

PF-R03S

CAD

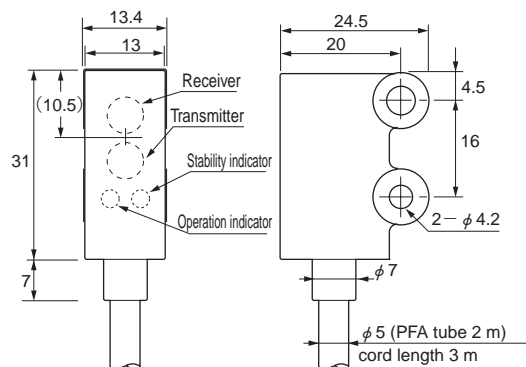

(The only indicator on the transmitter is power indicator.)

PF-V2 volume unit (optional)

CAD

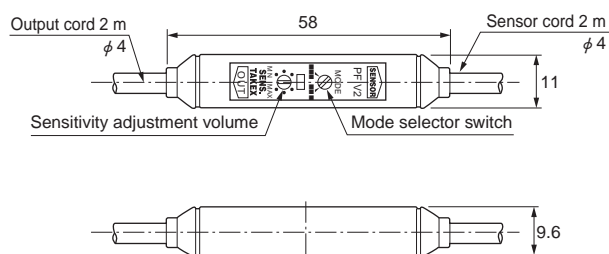

With mounting bracket HZ-01 attached

CAD

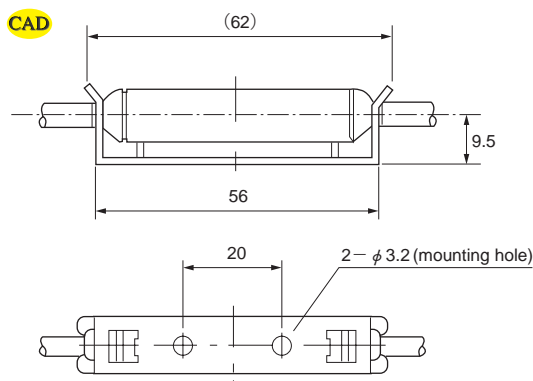

For Correct Use

- Do not bend the PFA tube into a radius of 30 mm or smaller.
- The tensile strength and bending strength of the sensor body and tube should be 0.2 N·m max.
- This product can be used under water at a depth of 50 cm at most. Be sure to refer to the chemical resistance performance table to check resistance before using the sensor in chemical solution.
- Do not use the sensor in hazardous environment requiring.
- To extend the cord, use wires of at least 0.3 mm². Do not extend the cord between the sensor and external volume.
- Use M4 screws to mount the sensor. When using stainless steel screws, the tightening torque should be 0.6 N·m max. For higher chemical resistance, use fluoroplastic (PFA) screws.
- While PFA (fluoroplastic) has resistance to chemicals, it is not completely chemical proof against fluorine or strongly acidic chemicals. The durability may vary depending on the permeability, erosiveness or temperature of chemicals and sensor operating condition.
- The electric operation guarantee period of the product is 1 year after delivery. The resistance to chemicals of PFA in terms of appearance is not covered since the durability may vary.



- Simple operation of just pressing button
Single touch can make adjustment for transparent object with high transmission
Optical system capable of fine detection of transparent objects employed
- Reflector exclusively for transparent container detection
Tarnish-proof reflector especially designed for transparent objects employed
- Equipped with inverter light suppression circuit
Faulty operation under inverter fluorescent lamps prevented
- IP 67 water resistance allowing washing

Type

Detection method	Detecting distance	Model	Operation mode	出力モード
 Reflector type	 0.1-1m	GA-MT1R	Light-ON/ Dark-ON	NPN open collector
		GA-MT1RPN	selectable (by teaching)	PNP open collector

Optional Parts

Type	Model	Description
Mounting bracket	GA-B1	Vertical mounting bracket
	GA-B2	Horizontal mounting bracket
Protective cover	G-MSB1	Rigid protective cover doubling as mounting bracket.
	G-MTB1	
	G-K7B	
Reflector	K-MT4	Accessory (when purchase separately)

Mounting brackets do not come with sensors. Select and purchase appropriate models according to the mounting conditions

Sensitivity adjustment for transparent object detection difficult with conventional volume type made by single-touch operation

Sample Applications

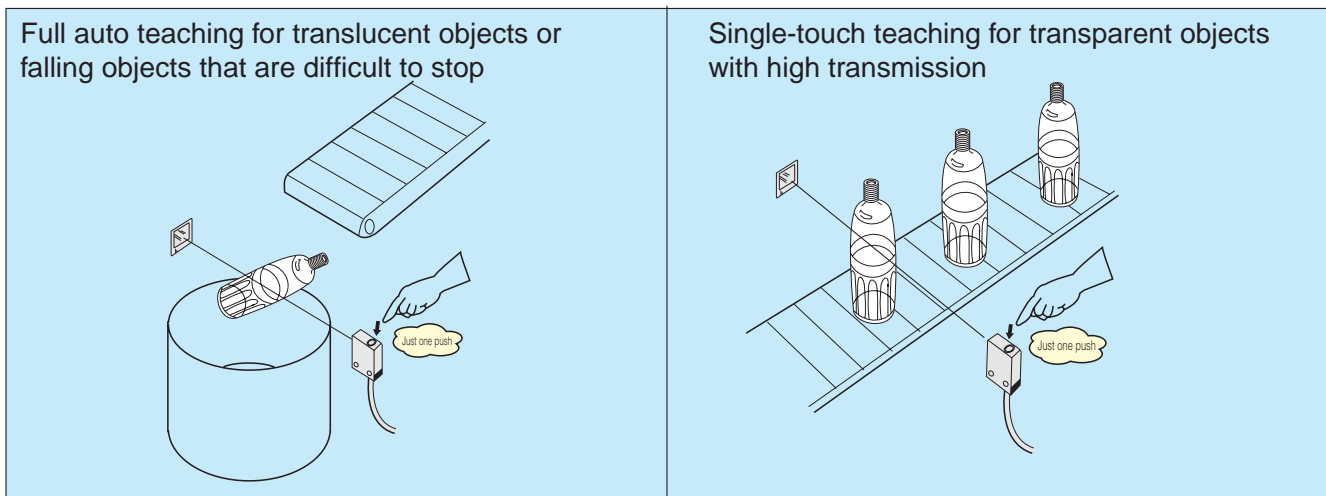

Rating/Performance/Specification

	Type	NPN output type	PNP output type	
	Model	GA-MT1R	GA-MT1RPN	
Rating/performance	Detection method	Reflector type		
	Detecting distance	0.1-1m (with K-MT4 reflector)		
	Power supply	12-24V DC $\pm 10\%$ / Ripple 10% max.		
	Current consumption	25mA max.	25mA max.	
	Output mode	Control output	NPN open collector	PNP open collector
		Rating	Sink current 100 mA (30 VDC) max. Residual voltage: 1 V or less	Source current 100 mA (30 VDC) max. Residual voltage: 1 V or less
		Stability output	NPN open collector	PNP open collector
	Rating	Sink current 50 mA (30 VDC) max. Residual voltage: 1 V or less	Source current 50 mA (30 VDC) max. Residual voltage: 2 V or less	
	Operation mode	Light-ON/Dark-ON selectable		
	Response time	1ms max.		
Specification	Light source	Red LED (700 nm)		
	Indicator	Operation indicator (orange LED)	Stability indicator (green LED)	
	Setting button	For sensitivity setting and Light-ON/Dark-ON selection *1		
	Short circuit protection	Provided		
	Material	Sensor	Lens: acrylic Case: polycarbonate	
		Reflector	Mirror: acrylic / Base: heat-resistant ABS	
	Connection	Permanently attached cord (outer dimension: dia. 4.2) 0.2 sq. 4 core 2 m length		
	Mass	Body: about 60 g / Reflector: about 15 g		
	Notes	Special reflector (K-MT4), operation manual, explanation sticker, (Note) mounting bracket separately available		

*1 Factory settings Sensitivity: Max.
Mode: Dark-ON

Environmental Specification

Ambient light	5,000 lx max.
Ambient temperature	-25 - +55°C (non-freezing)
Ambient humidity	35~85%RH (non-condensing)
Protective structure	IP 67
Vibration	10-55 Hz / 1.5 mm amplitude / 2 hours each in 3 direction
Shock	500 m/s ² / 3 times each in 3 directions
Dielectric withstanding	1,000 VAC for 1 minute
Insulation resistance	500 VDC, 20 MΩ or higher

Input/Output Circuit and Connection

NPN output
GA-MT1R

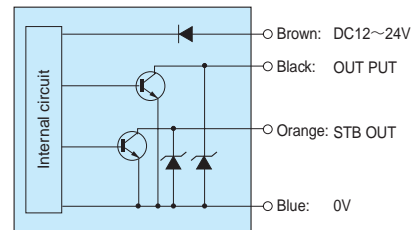

PNP output
GA-MT1RPN

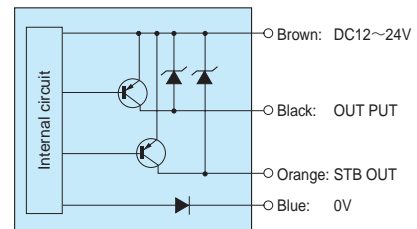

Directional characteristics (Typical example)

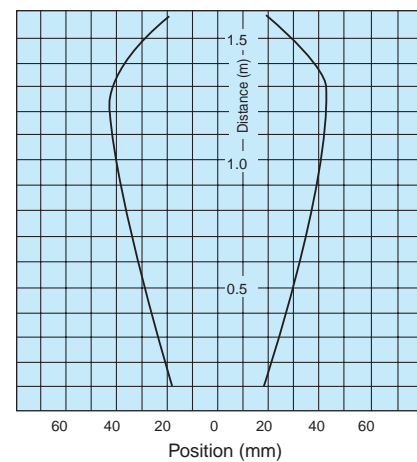

Indicators

The figure below shows the illumination of operation and stability indicators for different received light intensity levels. Set the sensitivity in such a way that the sensor operates in a sensitivity range that allows stable activation.

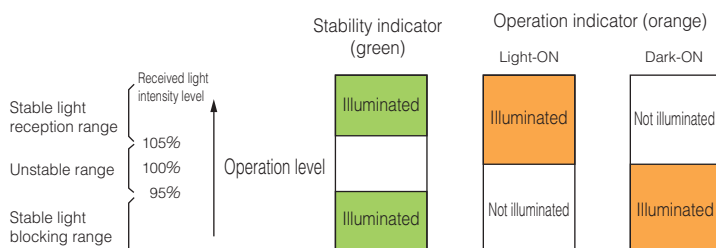

Stability output

When seven consecutive detections have occurred with the intensity of light detected not reaching the stable light reception range, the stability signal is output.

GA-MT1R GA-MT1RPN

For Correct Use

Be sure to follow the instructions in the operation manual provided for correct use of the product.

Part names

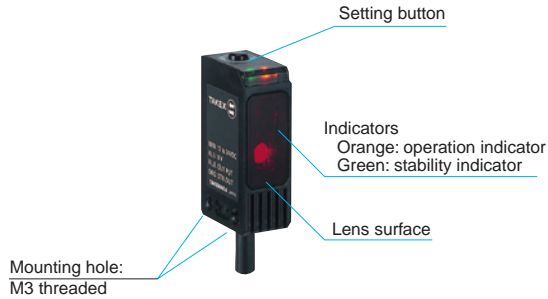

This sensor only has one setting button and no sensitivity adjustment volume or selector switch. Light-ON/Dark-ON switching and sensitivity setting are handled with the setting button alone. Enter the sensitivity setting mode or Light-ON/Dark-ON switching mode by pressing and holding down the button for a period of time as specified below:

Hold down setting button for 2-4 seconds ⇒ Sensitivity setting mode
 Hold down setting button for 5 seconds or longer ⇒ Light-ON/Dark-ON switching mode

Switching between Light-ON/Dark-ON mode

The factory setting is Dark-ON mode. Be sure to check and set either the Light-ON or Dark-ON mode before setting the sensitivity. Enter the Light-ON/Dark-ON switching mode by pressing the setting button for 5 seconds or longer. While the button is operated, the state of the output before starting the operation of the button is maintained.

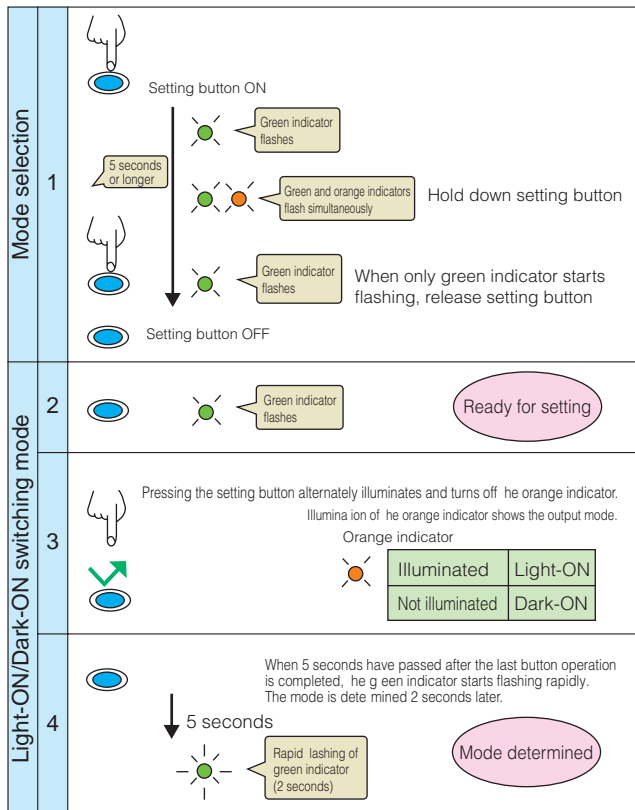

Sensitivity setting

The factory setting is maximum sensitivity. Adjust the sensitivity as required according to the state of the detection object or sensor mounting condition. Use the table below as guidelines:

Detection object	Sensitivity setting
Transparent object with high transmission such as PET bottle	Single-touch teaching-1
Translucent object such as milky white plastic case	Single-touch teaching-2
Continuously moving object such as falling object	Full auto teaching
Object that completely blocks light such as corrugated cardboard box	Maximum sensitivity setting

Single-touch teaching-1 transparent object with high transmission such as PET bottle

With the work removed, select the sensitivity setting mode. Then place the work at a given position and press the setting button once.

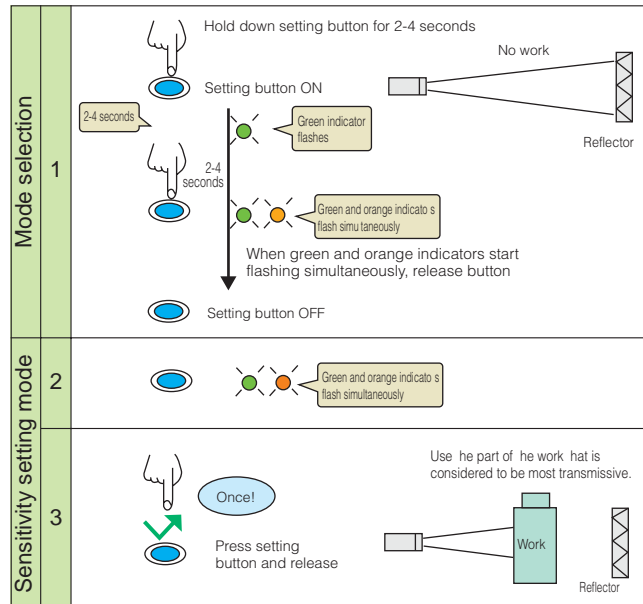

Single-touch teaching-2 translucent object such as milky white plastic case

No work needs to be placed. Set the sensitivity while the light is received. Just a single operation of the button sets the optimum sensitivity for the given received light intensity.

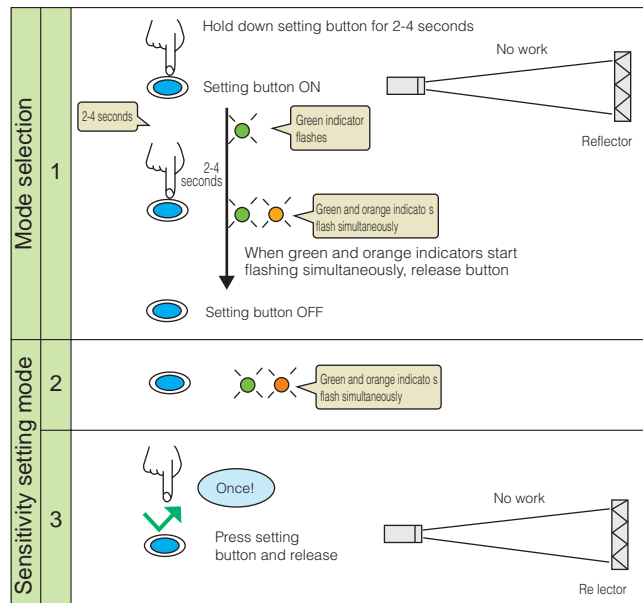

For Correct Use

Be sure to follow the instructions in the operation manual provided for correct use of the product.

Full auto teaching

When it is not possible to make "no-work" state as in detection of continuously moving (e.g. falling) object

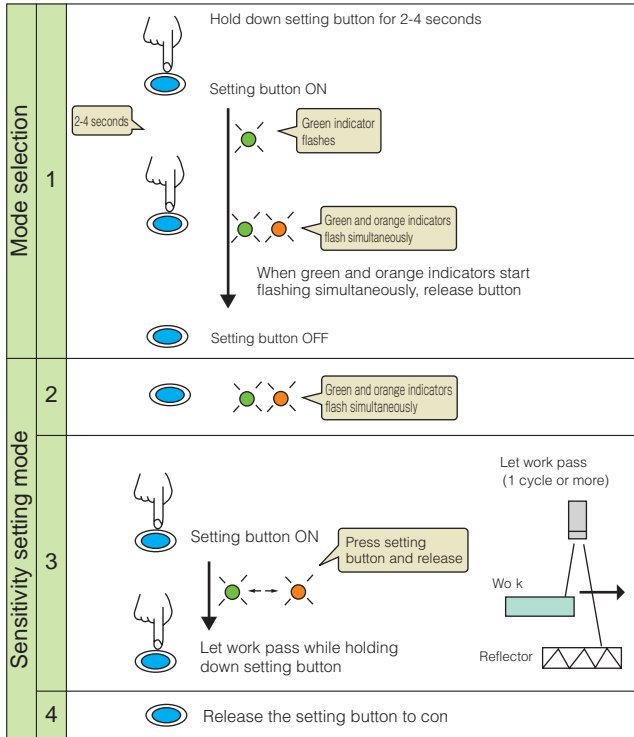

Maximum sensitivity setting

Enter the sensitivity setting mode with the light blocked and press the setting button once. The sensitivity is set at the maximum, which is the factory setting.

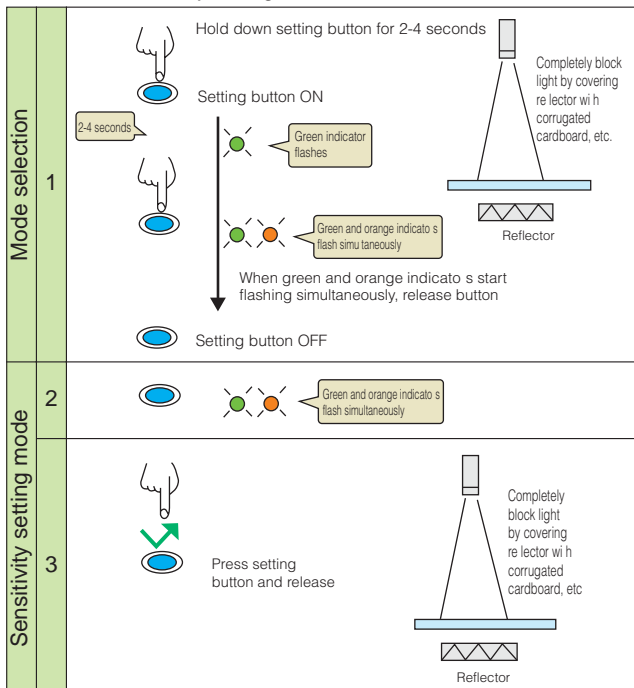

Installation

- Use the special reflector (K-MT4) that comes with the sensor. Using other types of reflector may degrade the performance of the product.
- No mounting bracket is provided. Purchase mounting brackets separately available according to the application.
- Sensor mounting**
For securing the sensor, use screws of an adequate length. If the effective length of the screw to the sensor is too short, the thread of the sensor may be damaged. The mounting holes in the sensor are M3 threaded. Select M3 screws of an appropriate length so that the screw-in length to the body of the sensor will be at least 10 mm. The tightening torque should be up to 0.5 N·m.
- Secure the sensor firmly on a solid base so that the sensor will not move when the setting button is pressed. Inadequate securing allowing the sensor to move when the setting button is pressed hampers accurate sensitivity setting.
- Make sure that the sensor and reflector are fixed before use. If the sensor or reflector is allowed to move, the operation may become unstable. Rotation of the reflector with reference to the sensor is especially likely to cause problems such as chattering.
- If the ambient temperature is low enough for freezing to occur, the operation of the setting button may not feel smooth. In such a case, press hard until the indicator flashes.

Dimensions (in mm)

Sensor body

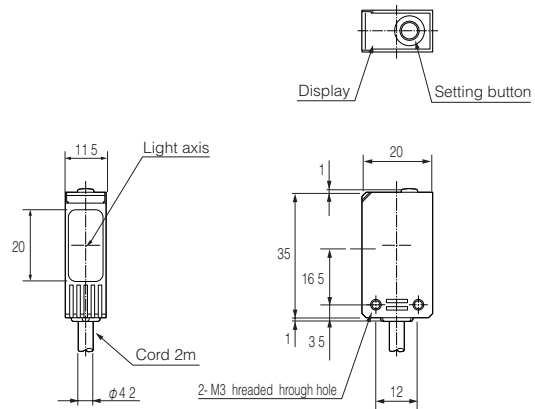

Reflector K-MT4

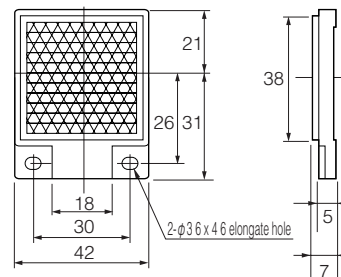

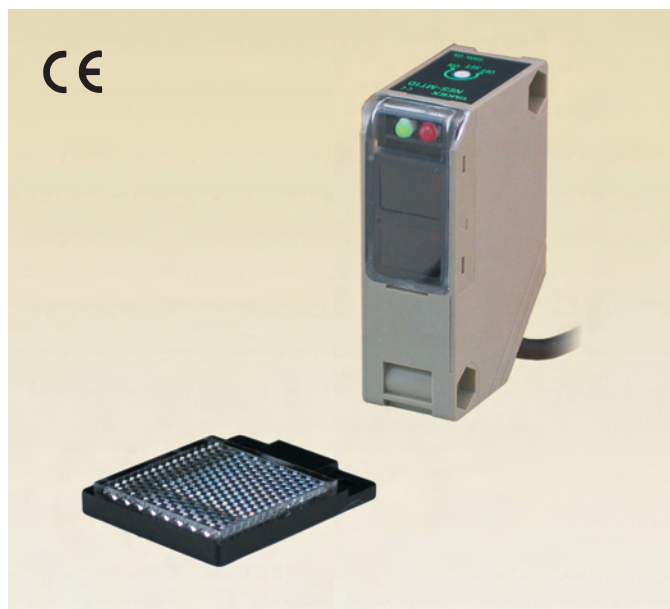



- Transparent objects such as PET bottles and ampoules detectable
- Teaching method for sensitivity adjustment is employed for less variation and automatic of optimum sensitivity, allowing reliable detection

- Full auto teaching: set without stopping work
- Auto teaching: set with work stopped
- External teaching: setting from a distant location

Type

Detection method	Detecting distance	Model	Operation mode	Output mode
 Polarization reflector type	 0.2~1m	NES-MT1	Light-ON	NPN open collector
		NES-MT1D	Dark-ON	

Sample Applications (In preparation for the unlikely event of unstable detection due to lens effect, etc., check the operation using sample objects.)

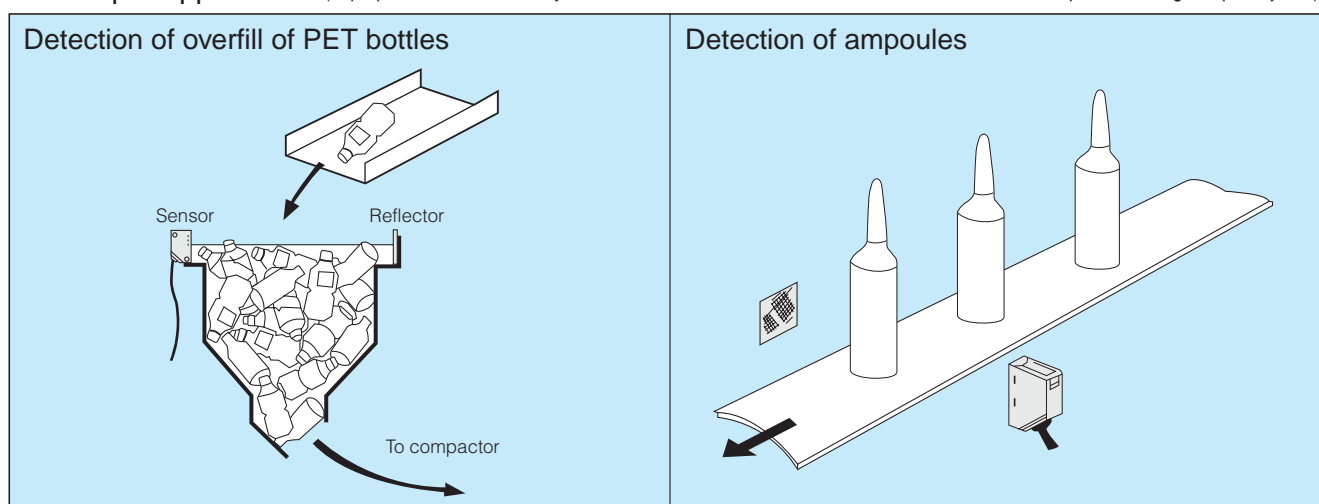

Rating/Performance/Specification

	Model	NES-MT1	NES-MT1D	
Rating/performance	Detection method	Polarization reflector type		
	Detecting distance	0.2-1m (with K-MT4, reflector provided for sensor)		
	Power supply	12-24V DC $\pm 10\%$		
	Current consumption	30mA max.		
	Output mode	NPN open collector output		
	Output rating	Sink current 100 mA (30 VDC) max. Residual voltage: 1 V or less		
	Operation mode	Light-ON	Dark-ON	
	External teaching	No-voltage input (contact/non-contact)		
	Response time	1ms max.		
	Operating angle	30° (at reflector)		
Specification	Light source (wavelength)	Red LED (700nm)		
	Indicator	Light reception indicator (Red LED) Stability indicator (green LED)		
	Sensitivity adjustment	Full auto teaching/auto teaching with rotary switch (provided) or external teaching input		
	Protection circuit	Output short circuit protection, reverse connection protection		
	Material	(Sensor) Lens: acrylic / Case: heat-resistant ABS (Reflector) Mirror: acrylic / Base: heat-resistant ABS		
	Connection	Permanently attached cord (outer dimension: dia. 4) 0.2 sq. 4 core 2 m length		
	Mass	Sensor: about 150 g (including mounting bracket) / Reflector: about 15 g		
	Accessory	Mounting bracket, screwdriver for teaching, reflector (K-MT4), operation manual		

Dimensions (in mm)

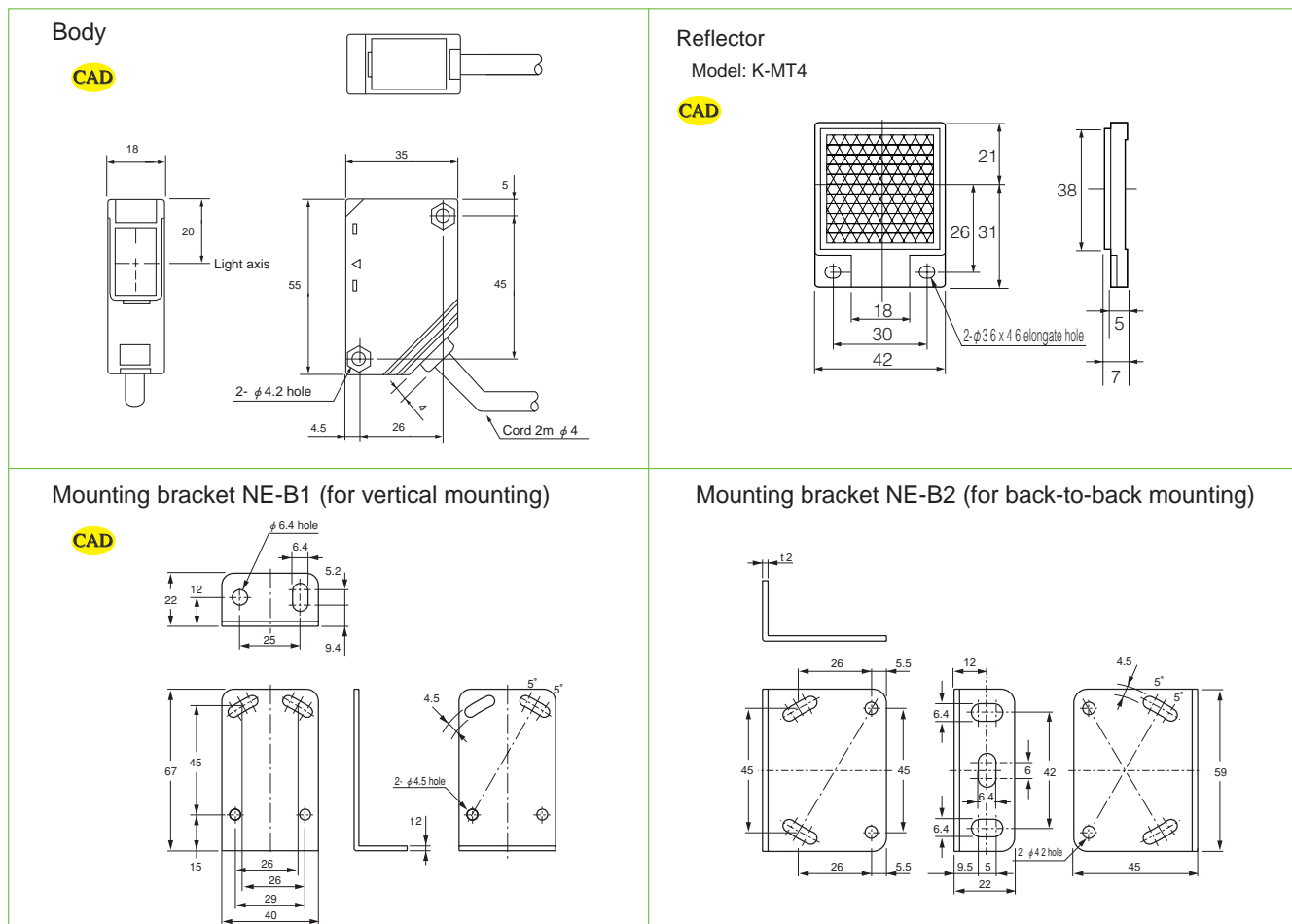



NAL-M10R

Long-distance polarization reflector type
Embedded amplifier photo sensors



- Long distance detection up to 10 m achieved with reflector type
- Capable of reliably detecting mirror surface objects
- NPN/PNP output
- Stable operation checked in one view with stability indicator

Type

Detection method	Detecting distance	Model	Operation mode	Output mode	Power supply
 Polarization reflector type	 0.5~10m	NAL-M10RTC	Light-ON/ Dark-ON selectable (with switch)	NPN/PNP open collector output	DC12-24V

- Long detecting distance of 10 m ideal for detection of large objects and use on large conveyors
- Reflector type only requiring wiring for one unit contributing to cost reduction

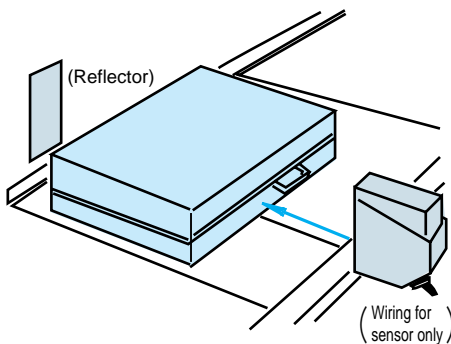
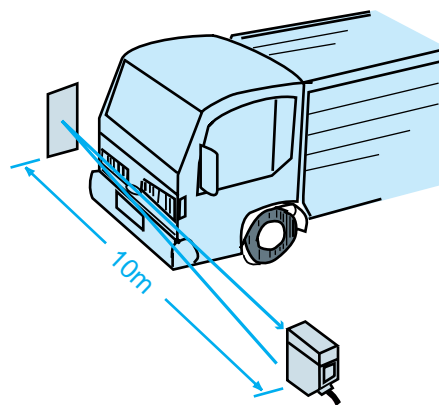

- Polarization reflector capable of reliably detecting glossy objects
- Detecting condition checked at a glance with stability indicator

NAL-M10R

Rating/Performance/Specification

Model		NAL-M10RTC
Detection method	Polarization reflector type	
Detecting distance	0.5~10m *1	
Detection object	Mirror-like objects, opaque objects	
Power supply	12-24V DC \pm 10% / Ripple 10% max.	
Current consumption	30mA max.	
Output mode	NPN/ PNP open collector (2 outputs) Rating; 100 mA (30 VDC) max. (NPN: sink current PNP: source current)	
Operation mode	Light-ON/Dark-ON selectable	
Response time	0.5ms max.	
Operating angle	30° (at reflector)	
Light source	Red LED (670 nm)	
Indicator	Operation indicator (orange LED) Stability indicator (green LED)	
Switch	Light-ON/Dark-ON selector switch	
Short circuit protection	Provided	
Material	Case	Polycarbonate
	Lens	Acrylic
	Terminal cover	Polycarbonate
	Mounting bracket	Stainless steel (SUS 304)
Connection	Terminal block (with M3.5 screws)	
Mass	200 g max. (including mounting bracket)	

*With reflector model K-77 (accessory)

Environmental Specification

Ambient light	Sunlight: illumination on light receiving surface 10,000 max.
	Incandescent lamp: illumination on light receiving surface 3,000 max.
Ambient temperature	-25 - +55°C (non-freezing)
Ambient humidity	35-85%RH (non-condensing)
Protective structure	IP 67
Vibration	10-55 Hz / 1.5 mm amplitude / 2 hours each in 3 direction
Shock	500 m/s ² / 3 times each in 3 directions
Dielectric withstanding	1,000 VAC for 1 minute
Insulation resistance	500 VDC, 20 MΩ or higher

Input/Output Circuit and Connection

- Open collector output

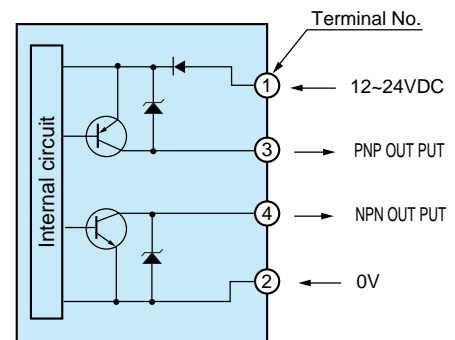

The output transistor turns off when load short circuit or overload occurs. Check the load and turn the power back on.

Directional characteristics (Typical example)

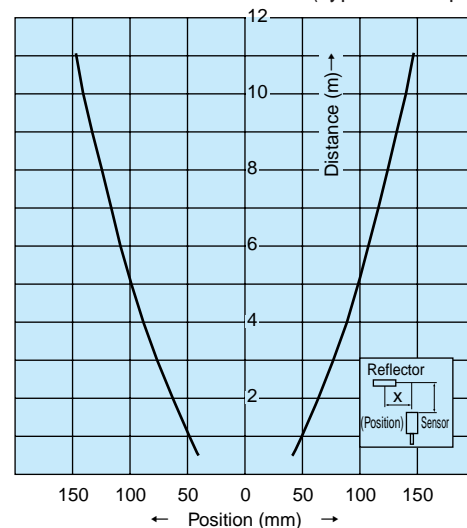

NAL-M10R

For Correct Use

Operation panel

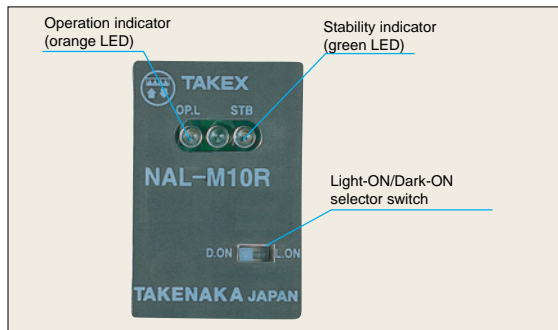

- ◆ **Operation indicator(O.P)**
Orange LED illuminated when output is activated
- ◆ **Stability indicator(STB)**
Green LED illuminated when the received light level is within the range allowing stable activation (120% or more of the operation level) or stable deactivation (80% or less of the operation level).
- ◆ **D.ON/L.ON selector switch**
D.ON: output activated when light is blocked
L.ON: (output activated when light is received)

Indicators

- The operation indicator (orange LED) and stability indicator (green LED) respectively show different received light intensity levels as described in the figure below.

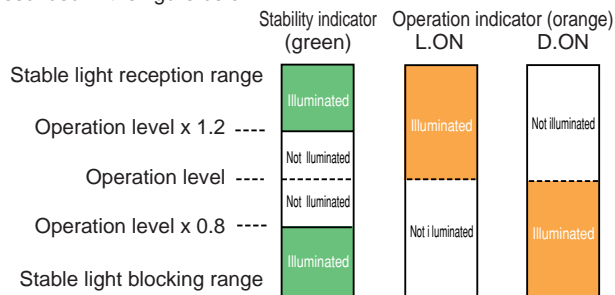

- Repeat activation and deactivation to make sure that the sensitivity is in the stable activation/deactivation range.
- Setting within the stable range increases the reliability against variation of environment after setting.

Detecting distances for different reflectors

The detecting distance depends on the reflector used.

Reflector model	K-77	K-7	K-71	S-510G
Detecting distance	0.5~10m	0.5~7.5m	0.5~4m	0.5~6m
Remarks	Accessory	Optional	Optional	Optional



- Do not use the product for the protection of human body.
- When using the product for safety purposes, ensure safety with the control system as a whole as well as the detection.
- This product is not explosion proof.

NAL-M10R

Dimensions (in mm)

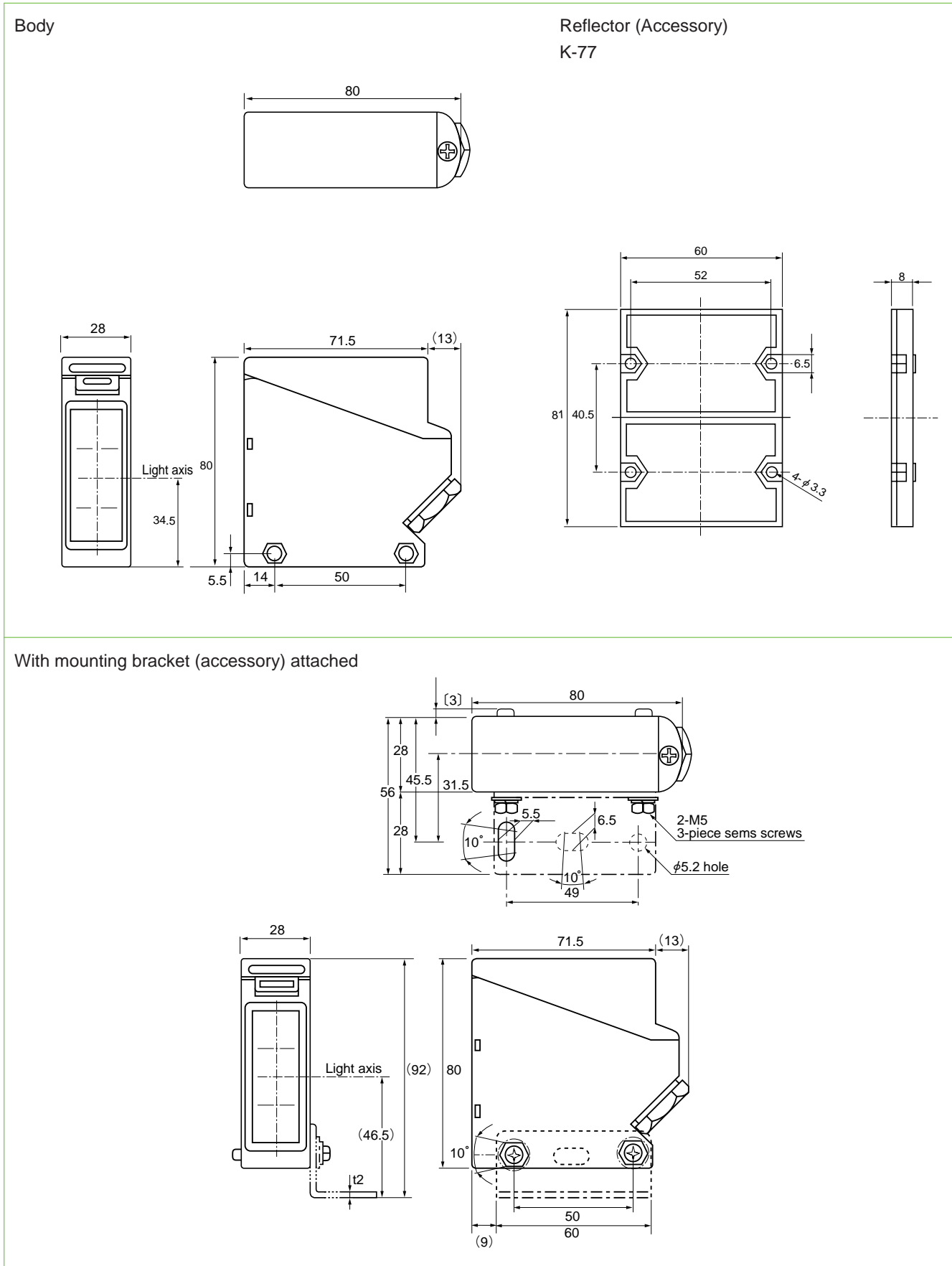

NE-DC Series

Embedded Amplifier Photo Sensors

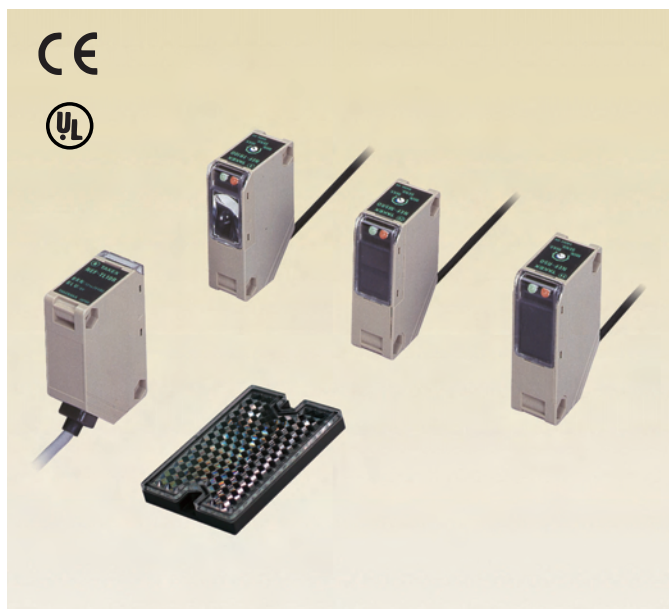

- Longest-in-class detecting distance
(30 m with through-beam style sensor)
Through-beam type: 10 m, 30 m
Reflector type: 5 m
Diffuse-reflective type: 1 m
- Polarization reflector method reliably detects mirror-like objects
- Red LED light source for ease of adjustment
(through-beam 10 m model, polarization reflector model)
- External light emission stop input feature is convenient for checking "before" operation, prevention of interference and timing (through-beam type only)
- Polarization filter (separately available) for adjacent mounting of 2 units (through-beam type NE-T10RD-DC)

Type

Detection method	Detecting distance	Model		Light source	Output mode
		Dark-ON mode	Light-ON mode		
Through-beam type	10m	NE-T10RD-DC	NE-T10R-DC	Red LED	NPN/PNP open collector
		NE-T10RD-DC-J	NE-T10R-DC-J		
	30m	NE-T30D-DC	NE-T30-DC	Infrared LED	
		NE-T30D-DC-J	NE-T30-DC-J		
Polarization reflector type	0.03~5m	NE-M5RD-DC	NE-M5R-DC	Red LED	
		NE-M5RD-DC-J	NE-M5R-DC-J		
Diffuse-reflective type	1m	NE-R10D-DC	NE-R10-DC	Infrared LED	
		NE-R10D-DC-J	NE-R10-DC-J		

Optional Parts

Type	Model	Applicable model	Description	
Pinhole plate	NE-P3	NE-T10R (D) -DC NE-T30 (D) -DC	Hole diameter ϕ 3 } Detecting distance with plate attached P.262	
	NE-P5			Hole diameter ϕ 5
	NE-P5 \times 1			Hole diameter 5 x 1mm
Reflector	K-71	NE-M5R (D) -DC	Detecting distance: 0.03-2m	
	K-2		Detecting distance: 0.3-3m	
	S-510G		Detecting distance: 0.1-3m	
Interference prevention filter	NE-PFA	NE-T10R (D) -DC	Longitudinal polarization filter	
	NE-PFB		Horizontal polarization filter	
Mounting bracket	NE-B1	All models	Vertical mounting	
	NE-B2		Back-to-back mounting	
Cord with M8 connector	FBC-4R2S	Permanently attached cord with connector (-J) type	M8 straight (2m)	
	FBC-4R2L		M8 angled (2m)	

Rating/Performance/Specification

Model	NE-T10RD-DC ※	NE-T30D-DC ※	NE-M5RD-DC	NE-R10-DC
Detection method	Through-beam type		Polarization reflector type	Diffuse-reflective type
Detecting distance	10m max.	30m max.	0.03~5m max. *1	1m max. *2
Detection object	φ 20mm (Min.) Opaque		Mirror-like objects (Note)/opaque objects/translucent objects	Opaque objects/translucent objects (Note 1)
Power supply	12-24V DC ±10% / Ripple 10%			
Current consumption	Transmitter: 5 mA max. Receiver: 15 mA max.	Transmitter: 20 mA max. Receiver: 15 mA max.	22mA max.	26mA max.
Output mode	NPN/PNP open collector 2 outputs Rating: 100 mA, (30 VDC) max. *3			
Operation mode	Dark-ON *4			Light-ON *5
Light emission stop function	Provided (no-voltage input)			—————
Response time	1ms max.		0.5ms max.	
Hysteresis	—————			10% max.
Operating angle	3° (at receiver)	5° (at receiver)	30° (reflector)	—————

*Set model No. Transmitter model: NE-TL10R-DC Receiver model: NE-TR10RD-DC
 Transmitter model: NE-TL30-DC Receiver model: NE-TR30D-DC

*1 With reflector model K-7 (accessory) *2 With standard detection object (200 x 200 mm white drawing paper)

*3 NPN: sink current; PNP: source current *4 Light-ON type available

*5 Dark-ON type available

Light source	Red LED (700nm)	Infrared LED (880 nm)	Red LED (700nm)	Infrared LED (880 nm)
Indicator	Transmitter: power indicator (red LED) *6 Receiver: operation indicator (red LED) Stability indicator (green LED)		Operation indicator (red LED) Stability indicator (green LED)	
Volume	—————		Sensitivity adjustment	
Material	Lens: Acrylic Case: heat-resistant ABS			
Connection *7	Permanently attached cord Transmitter: 0.3 sq. 3 core 2 m length Receiver: 0.3 sq. 4core 2 m length		Permanently attached cord Transmitter: 0.3 sq. 4 core 2 m length	
Mass	About 130 g (transmitter/receiver)		About 130 g	
Accessory *8	—————		K-7 reflector	—————
Notes	Light-ON type Model NE-T10R-DC	Light-ON type Model NE-T30-DC	Light-ON type Model NE-M5R-DC	Dark-ON type Model NE-R10D-DC

*6 Not provided for transmitter model NE-TL 10R-DC

*7 Connector type separately available (-J type: cord length 0.3 m)

*8 Mounting brackets are not provided. See Dimensions.

Environmental Specification

Ambient light	10,000 lx max.
Ambient temperature	-25 - +55°C (non-freezing)
Ambient humidity	35~85%RH (non-condensing)
Protective structure	IP66
Vibration	10-55 Hz / 1.5 mm amplitude / 2 hours each in 3 direction
Shock	100 m/s ² / 3 times each in 3 directions
Dielectric withstanding	500 VAC for 1 minute
Insulation resistance	500 VDC, 20 MΩ or higher

(Note) Some materials do not allow stable detection. Mirror-like objects wrapped in transparent film, glossy objects, laminated aluminum nameplates, etc., may inherently affect polarization. In such cases, the polarized waves of the sensor may be disturbed, which causes unstable detection.

(Note 1) Detecting objects with higher transmission may offer shorter detecting distances.

NE-DC

Input/Output Circuit and Connection

Transmitter

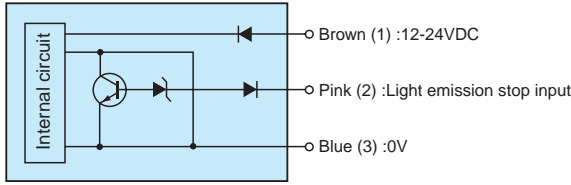

Receiver/sensor

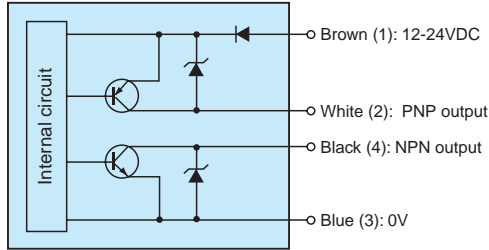

Connection

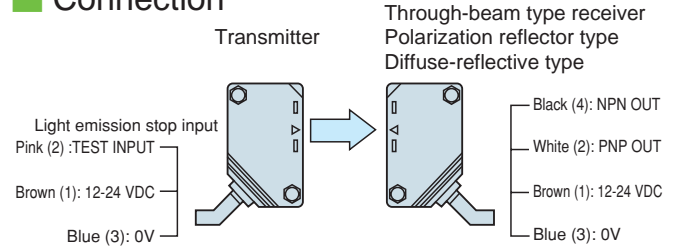

- The output transistor turns off when load short circuit or overload occurs. Check the load and turn the power back on.
- Circled numbers show connector pin Nos. for -J type.

Directional characteristics (Typical Example)

NE-T10R (D) -DC (-J)

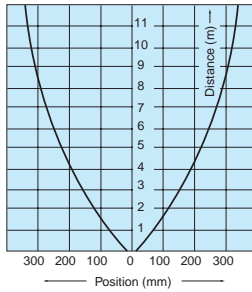

NE-M5R (D) -DC (-J)

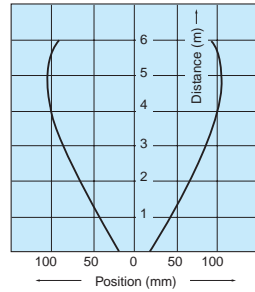

Activation area characteristics (Typical example)

NE-R10 (D) -DC (-J)

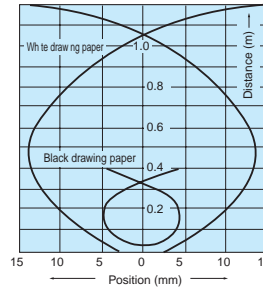

Distance-area characteristics (Typical example)

NE-R10 (D) -DC (-J)

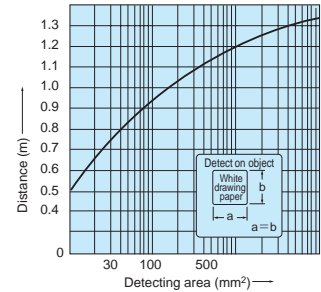

Pinhole Plate (optional)

Pinhole plates as described below are available for through-beam type models. Use of pinhole plates reduces the smallest allowable detection object diameter and activation area.

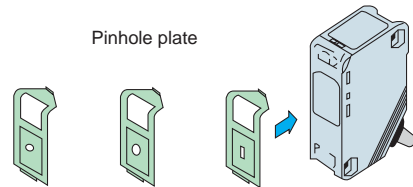

NE-P3 (φ 3) NE-P5 (φ 5) NE-P5×1 (5×1mm)

Detecting distance with plates attached to both transmitter and receiver

Sensor model	Pinhole plate model		
	NE-P3	NE-P5	NE-P5×1
NE-T10R(D)-DC	1m	3m	0.7m
NE-T30(D)-DC	3m	7m	2m

Detecting Distances for Different Reflectors (Model: NE-M5RD-DC)

The detecting distance depends on the reflector used.

Reflector model	Detecting distance
K-7 (Accessory)	0.03-5m
K-71	0.03-2m
K-2	0.1-3m
S-510G	0.1-3m

Indicators

- Light axis alignment and sensitivity adjustment are simple. Setting within the stable range increases the reliability against variation of environment after setting.
- The operation indicator (red LED) and stability indicator (green LED) respectively show different received light intensity levels as described in the figure.

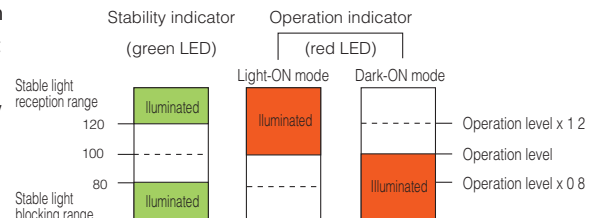

Dimensions (in mm)

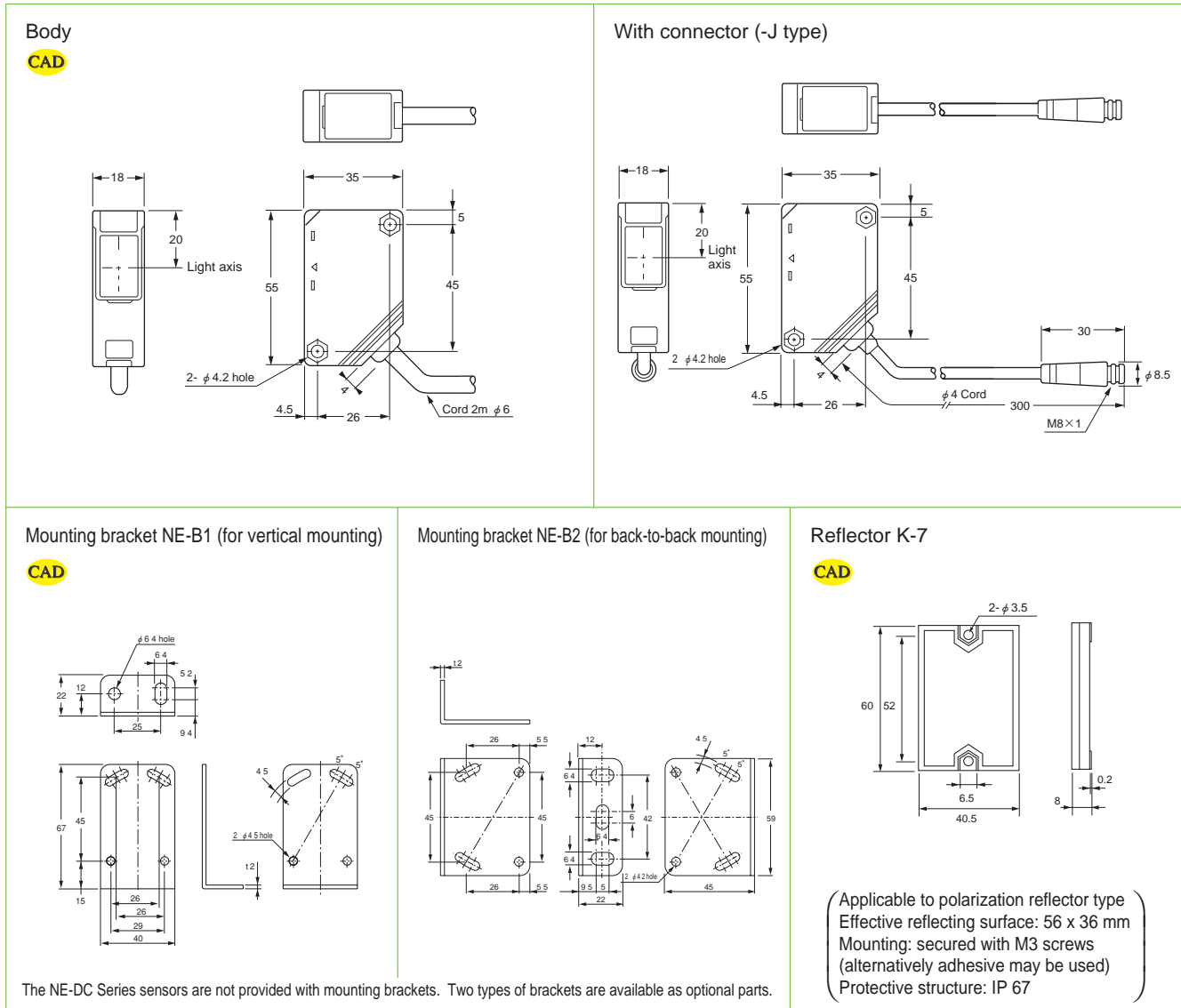

Attachment of Interference Prevention Filter (optional)

Model
NE-PFA (longitudinal type)
NE-PFB (horizontal type)

Use of filters allows adjacent mounting of through-beam type sensors. For adjacent mounting of two sensors, use the longitudinal type for one pair and horizontal type for the other.

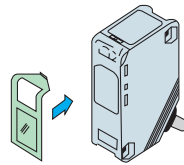

Insert into grooves at the top and bottom of the lens side of the transmitter and receiver.

Attach NE-PFA

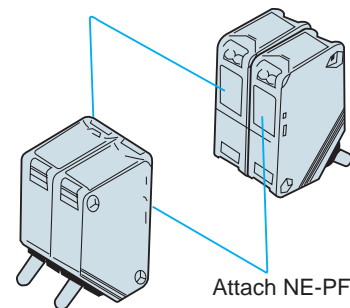

Attach NE-PFB

May be attached to model NE-T10R (D). The detecting distance with the filters attached is up to 5 m.

For Correct Use

- Avoid turning power "On and Off" consecutively.
- Do not use output signals in the transient condition while the power is turned on/off.
- The tightening torque for the sensor body and mounting bracket should not exceed 0.8 N·m max.
- While this product has a waterproof structure (IP 66), do not use in a place subject to constant water spray or under water. Also note that use in a place subject to corrosive gas, vibration/shock or direct splash of oils/chemicals may lead to faulty operation.

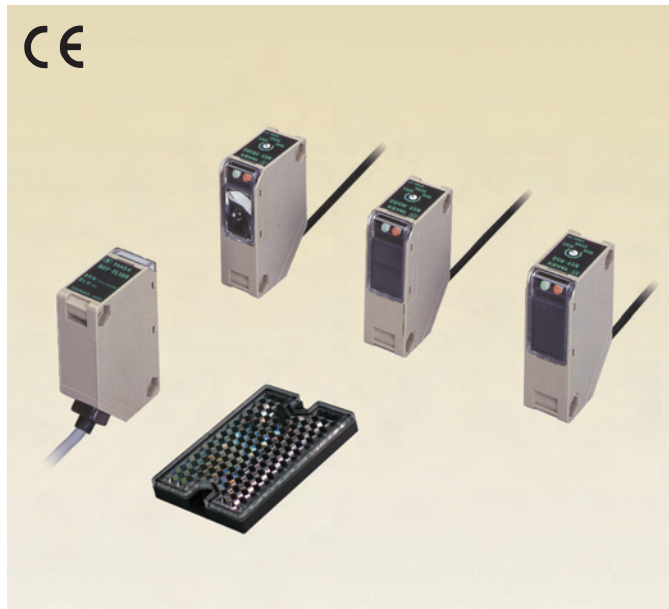

- Highly resistant to inverter noise as well as disturbing light including inverter fluorescent lamps or other light emitters
- Reasonably priced

Photo sensor ideal for use in places subject to:

- Lighting including fluorescent and mercury lamps
- Light emission of other photo sensors
- Various types of intense light such as the installation on carriages and vehicles

Type

Detection method	Detecting distance	Model	Operation mode	Output mode
Through-beam type	10m	NEF-T10RD	Dark-ON	NPN/PNP open collector (2 output)
Polarization reflector type	0.03-5m	NEF-M5RD		
Diffuse-reflective type	1m	NEF-R50	Light-ON	

Even more ensured stable detection

Stable detection of small objects

- Pinhole plate (optional)

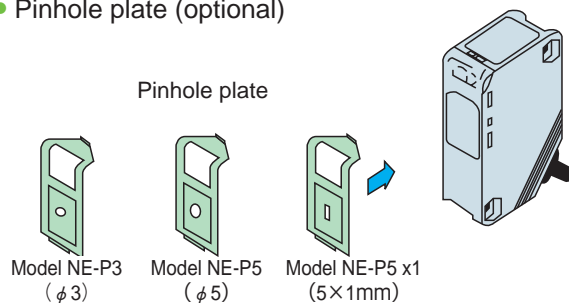

Detecting distance with plate attached (to both transmitter and receiver)

Model	NE-P3	NE-P5	NE-P5×1
Hole diameter	φ 3	φ 5	5×1
Detecting distance	1m	3m	0.7m

Adjacent mounting of through-beam type sensors

- Interference prevention filter (optional)

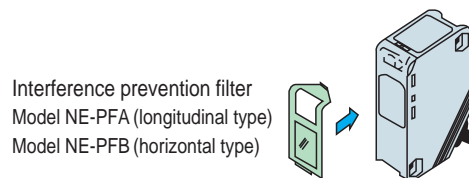

Interference prevention filter
Model NE-PFA (longitudinal type)
Model NE-PFB (horizontal type)

- Type

Product name	Model	Description
Pinhole plate	NE-P3	Hole diameter 3mm
	NE-P5	Hole diameter 5mm
	NE-P5×1	Hole diameter 5 x 1mm
Interference prevention filter	NE-PFA	Longitudinal polarization filter
	NE-PFB	Horizontal polarization filter

Rating/Performance/Specification

Model	NEF-T10RD	NEF-M5RD	NEF-R50
Detection method	Through-beam type	Polarization reflector type	Diffuse-reflective type
Detecting distance	10 max.	0.03~5m max. *	1m max.
Detection object	φ 20mm (Min.) Opaque	Mirror-like objects /opaque objects	Opaque objects/translucent objects
Power supply	12-24V DC ±10% / Ripple 10%		
Current consumption	Transmitter: 30mA max. Receiver: 25mA max.	40mA max.	
Output mode	NPN/ PNP open collector (2 outputs)		
Control output	NPN: sink current 100 mA (30 VDC) max. PNP: source current 100 mA (30 VDC) max.		
Operation mode	Dark-ON		Light-ON
Response time	5ms max		
Hysteresis			10 % max.
Operating angle	3° (at receiver)	30° (at reflector)	
Light source (Light wavelength)	Red LED (700 nm)		Infrared LED (880 nm)
Indicator	Transmitter: power indicator (red LED) Receiver: operation indicator (orange LED) Stability indicator (green LED)	Operation indicator (orange LED) Stability indicator (green LED)	
Volume (VR)	SENS: sensitivity adjustment (on receiver for through-beam type)		
Short circuit protection	Provided		
Material	Case	Heat-resistant ABS	
	Lens	Acrylic	
Connection	Permanently attached cord (outer dimension: dia. 6) Transmitter of through-beam type: 0.3 sq. 2 core 2 m length (gray) Receiver of through-beam type: 0.2 sq. 4 core 2 m length (black)		
Mass	Transmitter: About 130 g Receiver: About 150 g	About 150 g	
Accessory	K-7 reflector		
Note	Screwdriver for adjustment, mounting bracket, operation manual *With K-7 reflector (accessory)		

Environmental Specification

Ambient light	10,000 max.
Ambient temperature	-25 - +55°C (non-freezing)
Ambient humidity	35-85%RH (non-condensing)
Protective structure	IP 66
Vibration	10 55 Hz / 1.5 mm amplitude / 2 hours each in 3 direction
Shock	100 m/s ² / 3 times each in 3 directions
Dielectric withstanding	1000 VAC for 1 minute
Insulation resistance	500 VDC, 20 MΩ or higher

Input/Output Circuit and Connection

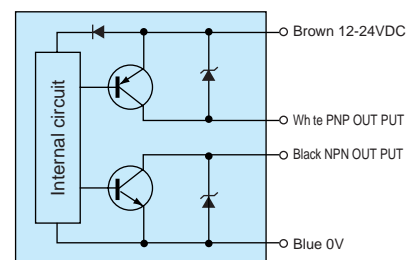

Dimensions (in mm)

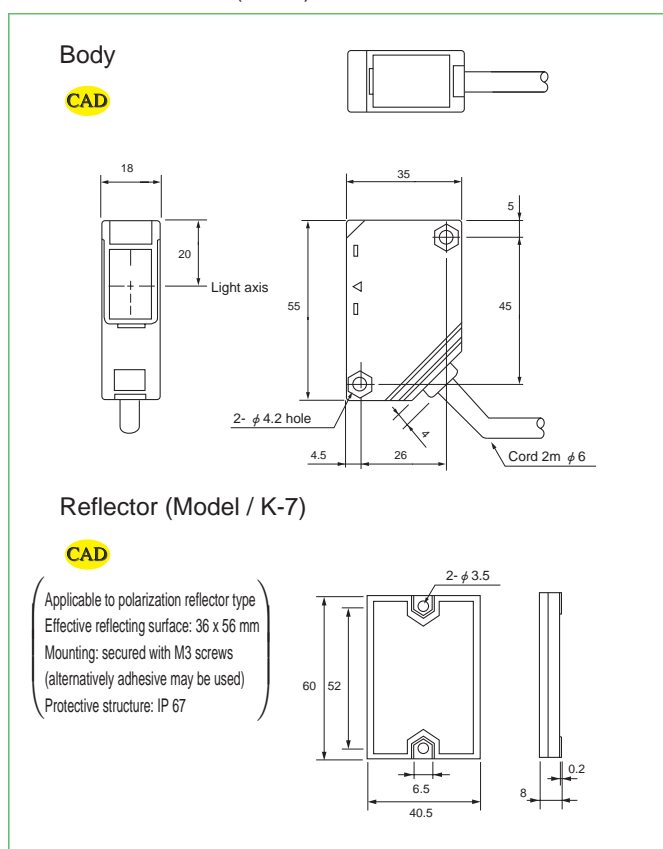

Connection

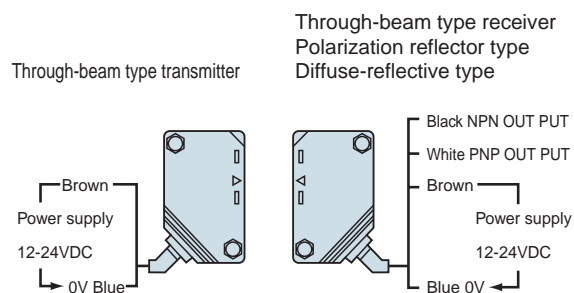

With mounting bracket provided attached

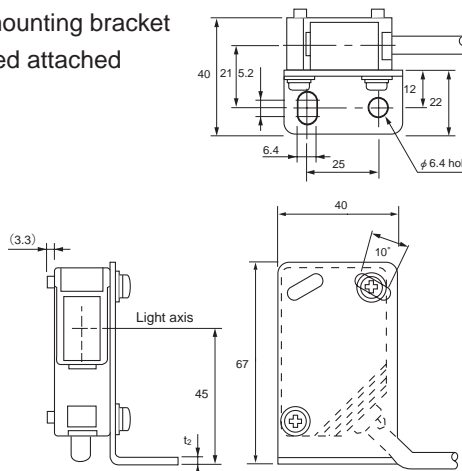

CE

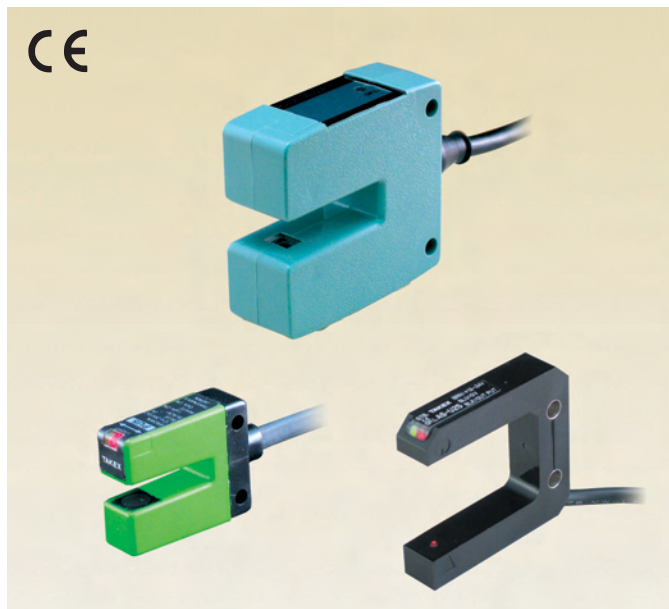

- No light axis alignment necessary
- Ideal for position checking or of stacker crane in automatic warehouse

Embedded Amplifier Photo Sensors

Type

Detection method	Detecting distance	Model		Operation mode	Output mode
		NPN type	PNP type		
U-shaped through-beam type 	5 mm fixed	PU5	—	Light-ON/ Dark-ON selectable (depending on cable)	NPN open collector
	10 mm fixed	PU10	—		Current output/ voltage output
	19 mm fixed	AS-U20	—	Light-ON	NPN open collector
		AS-U20D	—	Dark-ON	
	25 mm fixed	AS-U25	—	Light-ON	
		AS-U25D	—	Dark-ON	
	30 mm fixed	AS-U30	AS-U30PN	Light-ON	
		AS-U30D	AS-U30DPN	Dark-ON	

Sample Applications

<ul style="list-style-type: none"> • Positioning of forming machine, stepping motor, etc. 	<ul style="list-style-type: none"> • Detection of presence of liquid, powder, etc. 	<ul style="list-style-type: none"> • Specified-length cutting of sheet material
--	---	--

- 2-channel output type
2-channel output types are separately available
Model AS-U25-2
Model AS-U25D-2

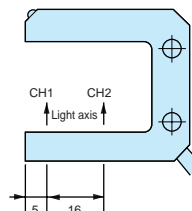

Rating/Performance/Specification

Model	PU5	PU10	AS-U20(D)	AS-U25(D)	AS-U30(D)
Detection method	Through-beam type (U-shaped)				
Detecting distance	5 mm fixed	10 mm fixed	19 mm fixed	25 mm fixed	30 mm fixed
Detection object	φ 1mm (Min.) Opaque	φ 2mm (Min.) Opaque			φ 5mm (Min.) Opaque
Power supply	12-24V DC ±10% / Ripple 10% max.				
Current consumption	20mA max.	45mA max.	25mA max.		35mA max.
Output mode	NPN open collector Sink current 100 mA (30 VDC) max.	Current output Sink current 75 mA (48 VDC) voltage output Output impedance: 4.7 kΩ	NPN open collector*2 Rating: sink current 100 mA (30 VDC) max.		
Operation mode	Light-ON/Dark-ON (2 outputs)		Dark-ON*1		
Response time	200 μs max.	50 μs max.	0.35ms max.		0.5ms max.
Light source (wavelength)	Infrared LED (910 nm)	Infrared LED (940 nm)	Red LED (650nm)		Red LED (950nm)
Indicator	Light reception indicator (red LED)		Operation indicator (red LED) Stability indicator (green LED)		Operation indicator (red LED)
Short circuit protection	—————		Provided		
Material	Case	Polycarbonate	Polycarbonate		Heat-resistant ABS
	Lens	Polycarbonate	Acrylic		
Connection	Permanently attached cord (outer dimension: dia. 5 x 3) 0.14 sq. 4 core 1 m length	Permanently attached cord (outer dimension: dia. 6.2) 0.3 sq. 4 core 3 m length	Permanently attached cord (outer dimension: dia. 4) 0.2 sq. 3 core 2 m length		Permanently attached cord (outer dimension: dia. 4.2) 0.3 sq. 3 core 2 m length
Mass	About 40g	About 220g	About 55g	About 60g	About 140g
Notes	*1 Light-ON type separately available AS-U20, as-U25, AS-U30 *2 PNP output type separately available AS-U30PN, AS-U30DPN				

Environmental Specification

Ambient temperature	AS series: -25 - +55°C (non-freezing) PU series: -10 - +55°C
Ambient humidity	35-85%RH (non-condensing)
Protective structure	IP67 (IP 40 for PU10)
Vibration	10-55 Hz / 1.5 mm amplitude / 2 hours each in 3 direction
Shock	500 m/s ² / 3 times each in 3 directions
Insulation resistance	500 VDC, 100 MΩ higher

- Applicable power supply unit
PS Series
High capacity of 200 mA at 12 VDC



- (General-purpose type) PS3N
PS3N-SR
- (Multifunctional type) PS3F
PS3F-SR

Input/Output Circuit and Connection

PU5

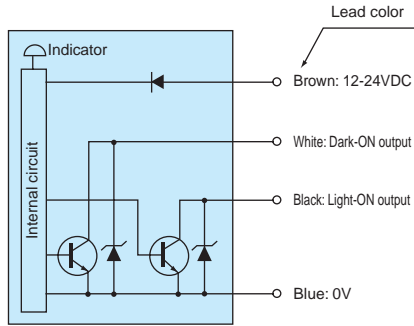

*Insulate any unused output lead.

PU10

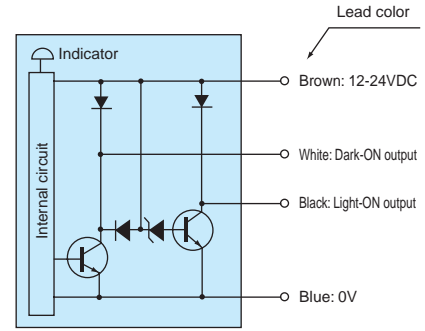

*Insulate any unused output lead

AS-U20
AS-U20D
AS-U25
AS-U25D
AS-U30
AS-U30D

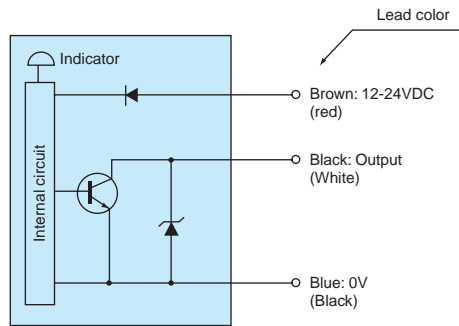

AS-U30PN
AS-U30DPN

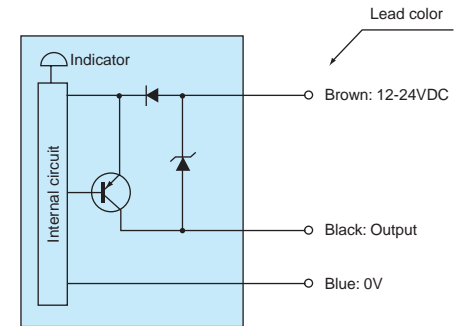

Dimensions (in mm)

PU5

CAD

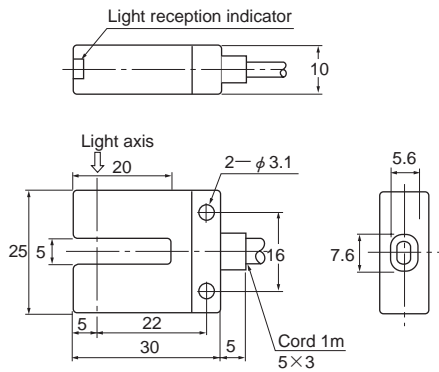

PU10

CAD

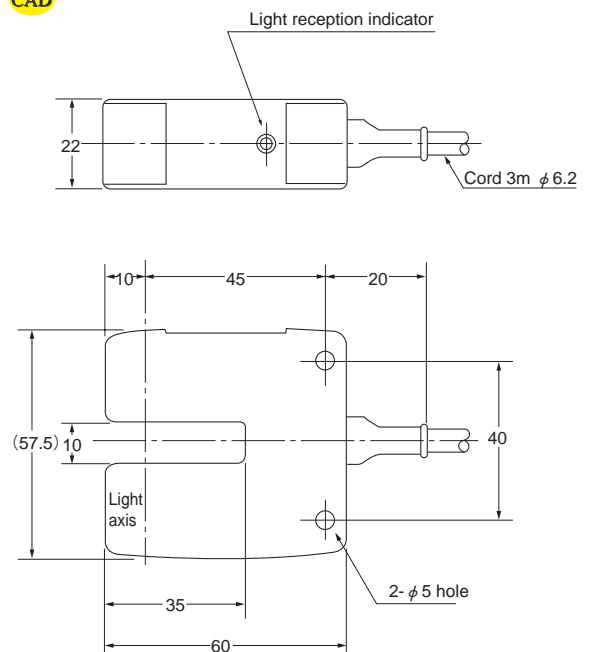

Dimensions (in mm)

AS-U20, AS-U20D

CAD

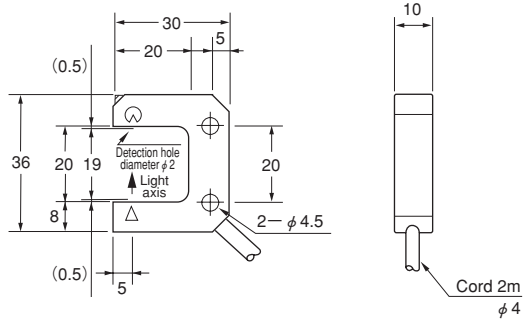

AS-U25, AS-U25D

CAD

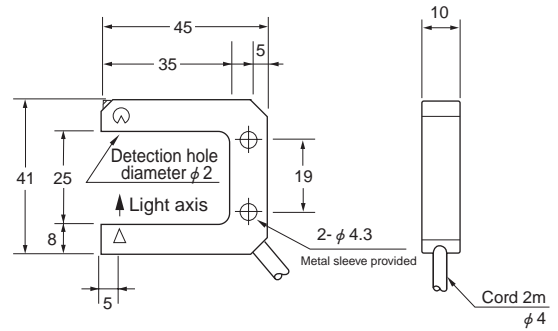

AS-U30(PN), AS-U30D(PN)

CAD

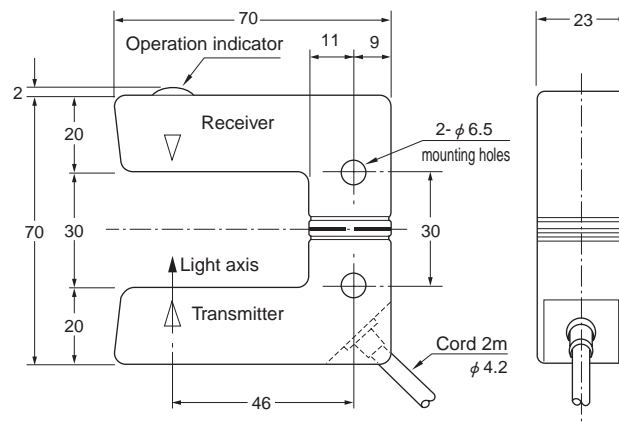

Reflector

Dimensions (in mm)

K-7

CAD

Applicable to polarization reflector type
 Effective reflecting surface: 56 x 36 mm
 Material: Mirror: acrylic / Base: heat-resistant ABS
 Protective structure: IP 67
 Mounting: secured with M3 screws (alternatively adhesive may be used)

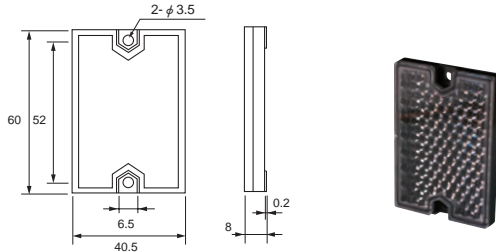

S-15

CAD

Effective reflecting surface: ϕ 15
 Mounting: Pasted: adhesive on back side

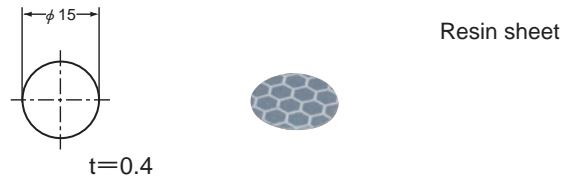

K-71

CAD

Applicable to polarization reflector type
 Effective reflecting surface: 32 x 19 mm
 Mounting: mounting bracket provided, secured with M3 screws (alternatively adhesive may be used)

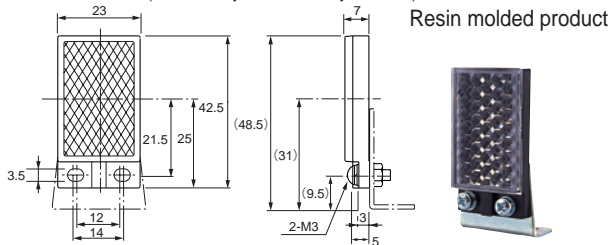

S-15B

CAD

Effective reflecting surface: ϕ 15
 Mounting: Secured by pasting or with M3 screws

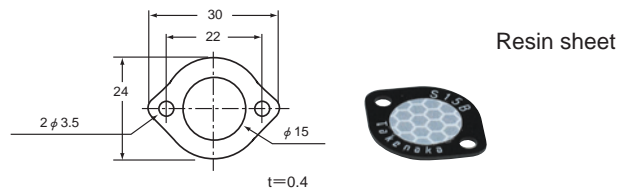

K-77

Applicable to polarization reflector type
 Effective reflecting surface: 68 x 56 mm
 Mounting: secured with M3 screws (alternatively adhesive may be used)

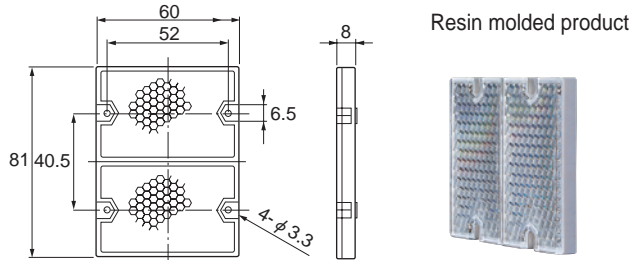

S-25

Effective reflecting surface: ϕ 18.5 mm x 25 per sheet
 Mounting: Pasted: adhesive on back side

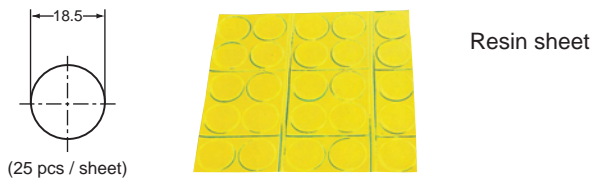

K-72

Applicable to polarization reflector type
 Effective reflecting surface: 29 x 8 mm
 Material: Mirror: acrylic / Base: heat-resistant ABS
 Protective structure: IP 67
 Mounting: mounting bracket provided, secured with M3 screws

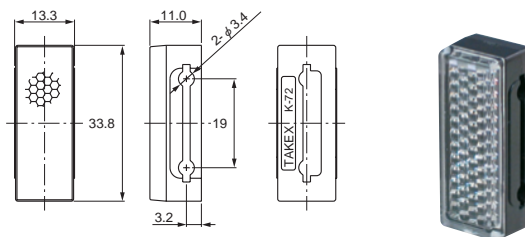

S-100
S-200

Effective reflecting surface: 100mm x 100mm (S-100)
 Mounting: Pasted: adhesive on back side

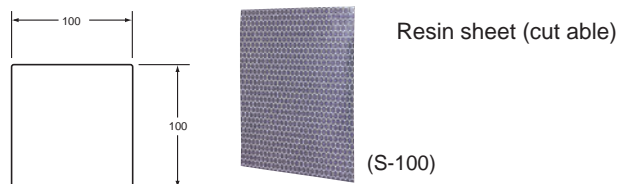

S-520
S-310-S

Applicable to polarization reflector type
 (S-520) Effective reflecting surface: 198 x 48 mm / Color: yellow
 (S-310-S) Effective reflecting surface: 98 x 28 mm / Color: Silver
 Mounting: Pasted: adhesive on back side

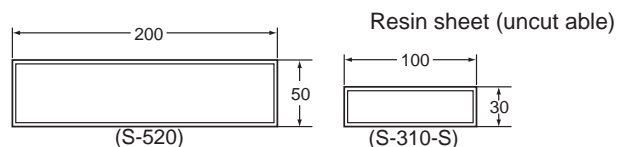

K-MT4

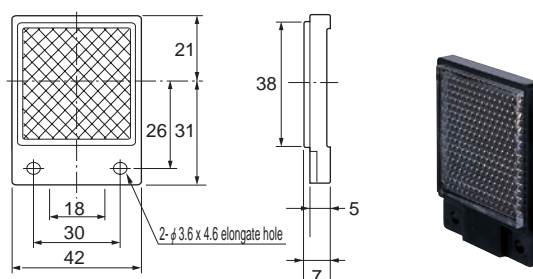

S-510G

Applicable to polarization reflector type
 Effective reflecting surface: 100 x 50mm
 Mounting: Pasted: adhesive on back side

