

WEG Automation Catalog

Power and Control Products

Contactors



Table of Contents

Index – Industrial Controls



Miniature Contactors – CWC Series

Standard Features..... 136
 Product Selection..... 138
 Accessories..... 142
 Technical Data..... 146
 Dimensions 154



IEC Contactors - CWB and CWBN Series

Standard Features..... 155
 IEC Product Selection 156
 NEMA Product Selection..... 156
 Accessories..... 157
 Technical Data 160
 Dimensions..... 170



CWBS Safety Contactors

Standard Features..... 172
 Product Selection..... 173
 Technical Data..... 174
 Dimensions..... 179



IEC Contactors – CWM and CWM-N Series

CWM Standard Features..... 181
 CWM Product Selection..... 185
 CWM-N Standard Features..... 189
 CWM-N Product Selection..... 192
 CWM and CWM-N Accessories..... 193
 CWMC Standard Features 196
 CWMC Product Selection 197
 Technical Data..... 197
 Dimensions..... 207

Contactors

Miniature Contactors - CWC Series

The CWC Series Mini Contactor Line is a Compact Solution for the Control and Operation of Circuits. Its extensive lineup of modular and tool-free accessories makes this series the most flexible mini-contactor available today. The CWC Series miniature contactor features more horsepower for its size than any other miniature contactor on the market.

Standard Features:

- Direct Mounting to RW17D Series Thermal Overload Relays
- Direct Mounting to MPW18 and MPW40 Series Manual Motor Protectors
- Low Consumption DC Coils
- Tool Free DIN Rail Mountable
- Frame size remains the same for AC and DC coil contactors up to 16A
- Complete line of snap-on accessories



UL File No. E202315

Mounting Position of All Compact Contactors

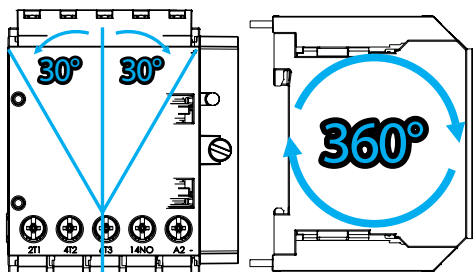

CWC Catalog Number Sequence

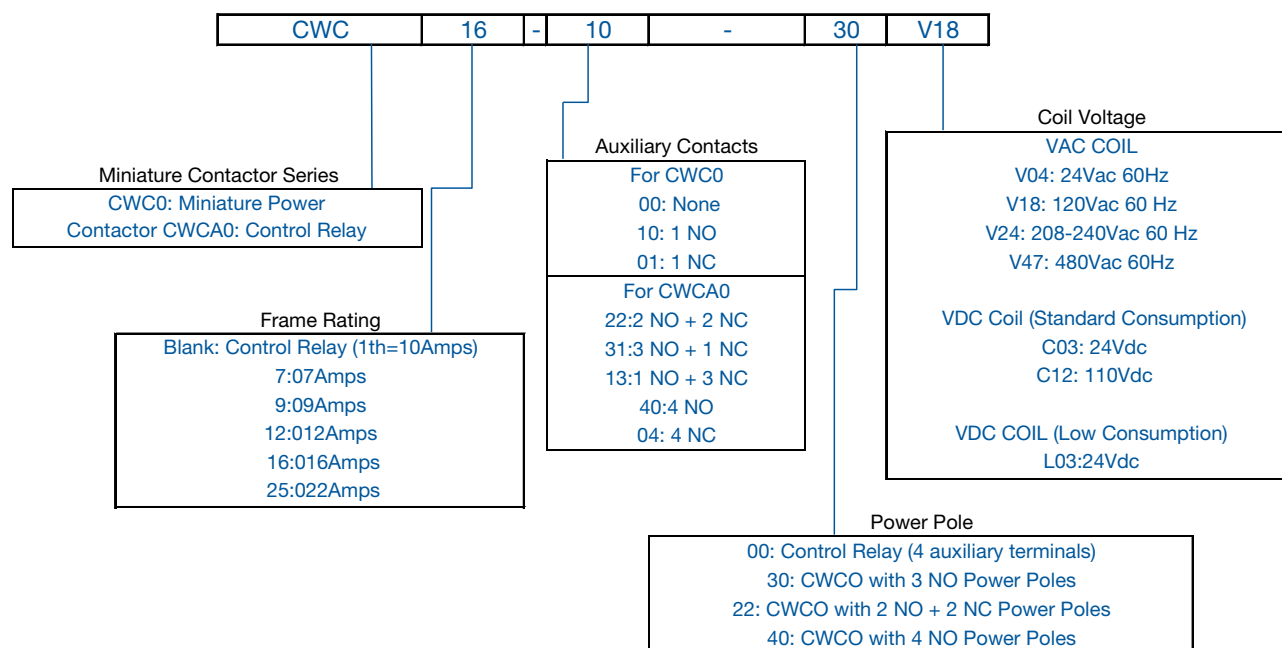
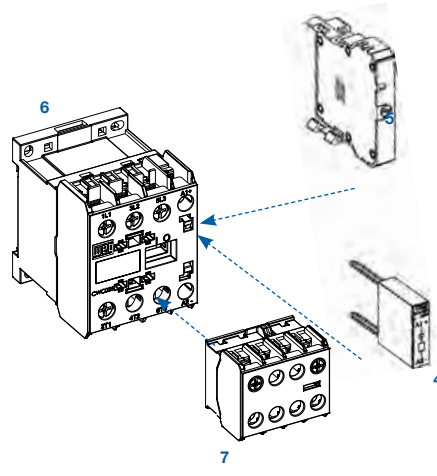
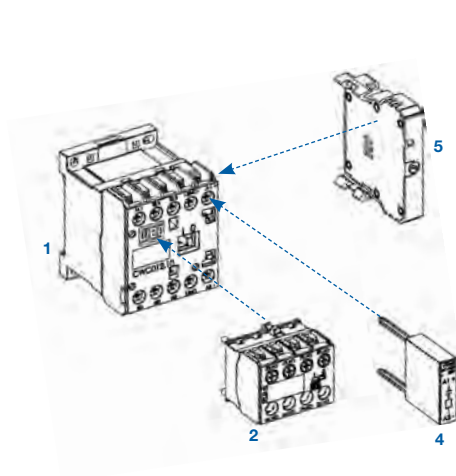
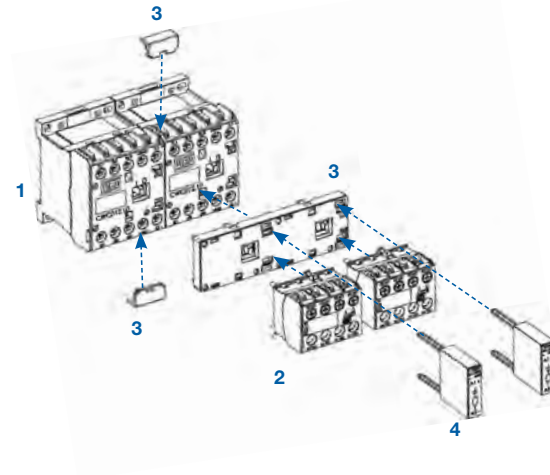

Chart intended for reference only and not to create part numbers











- 1 - Miniature contactors CWC07...16
- 2 - Front auxiliary contact block BFC0
- 3 - Mechanical interlock block BIC0
- 4 - Surge supressor blocks RCC0 (RC), VRC0 (Varistor), DIC0 (Diode)
- 5 - Electronic timers TEC0, TDC0 and TETC0
- 6 - Mini contactor CWC025
- 7 - Front auxiliary contact block BFC025



- General Information
- Circuit Protection
- Disconnect Switches
- Motor Protectors
- Contactors
- Overloads
- Enclosed Starters
- Relays
- Pushbuttons and Pilot Lights
- Terminal Blocks
- Power Factor Correction
- Appendix A
- Appendix B

CWC Series - Miniature Contactors

General Information	 						
Circuit Protection							
Disconnect Switches							
Motor Protectors							
Contactors							
Overloads							
Enclosed Starters							
Relays							
Pushbuttons and Pilot Lights							
Terminal Blocks							
Power Factor Correction							
Appendix A							
Appendix B							
	Type	3 poles	CWC07	CWC09	CWC012	CWC016	CWC025
	Rated operational power ¹⁾						
	Single-phase						
	115Vac	Hp	1/3	1/3	1/2	1	1 1/2
	230Vac	Hp	3/4	1	2	2	3
	Three-phase						
	230Vac	Hp	1 1/2	3	3	5	7 1/2
	460Vac	Hp	5	5	7 1/2	10	15
	575Vac	Hp	5	7 1/2	7 1/2	10	15
	General Purpose Rating (AC-1)	A	18	20	22	22	32
	Inductive Motor Switching (AC-3)		7	9	12	16	25
	Overload relay	A	 RW17-1D	0.28...0.4 0.4...0.63 0.56...0.8 0.8...1.2 1.2...1.8 1.8...2.8	2.8...4 4...6.3 5.6...8 7...10 8...12.5 10...15 11...17	 RW17-2D	7...10 8...12.5 10...15 11...17 15...23 22...32
	Auxiliary contact blocks			BFC0-20 (2NO) BFC0-22 (2NO + 2NC) BFC0-11 (1NO + 1NC) BFC0-04 (4NC) BFC0-02 (2NC) BFC0-31 (2NO + 1NC) BFC0-40 (4NO) BFC0-13 (1NO + 3NC)			BFC025-11 (1NO+1NC) BFC025-20 (2NO) BFC025-02 (2NC)
	Mechanical interlock			BICO			-
	Timer				ON-Delay (TECO) OFF-Delay (TDCO) Star-Delta (TETCO)		
	Surge suppressor				RC block: RCC0-1 D49 12-24V 50/60Hz RCC0-2 D53 24-48V 50/60Hz RCC0-3 D55 50-127V 50/60Hz RCC0-4 D63 130-250V 50/60Hz RCC0-5 D84 275-380V 50/60Hz RCC0-6 D73 400-510V 50/60Hz Varistor block: VRC0-1 E49 12-48VAC / 12-60VDC VRC0-2 E34 50-127VAC / 60-180VDC VRC0-3 E38 130-275VAC / 180-300VDC VRC0-4 E41 277-380VAC / 300-510VDC VRC0-5 D73 400-510V 50/60Hz Diode block(CWC07-16): DIC0-1 C33 12-60VDC		

Notes: 1) Some motor characteristics may vary according to each manufacturer.

Three Pole Miniature Contactor with AC Coil

Maximum UL Horsepower						Auxiliary Contacts		Current Rating Amps	Catalog Number	List Price	Multiplier
Single Phase		Three Phase				N.O.	N.C.				
115V	230V	200V	230V	460V	575V						
1/3	3/4	1-1/2	1-1/2	5	5	1	0	7	CWC07-10-30*	\$48	Z6
						0	1		CWC07-01-30*	\$48	
1/3	1	2	3	5	7-1/2	1	0	9	CWC09-10-30*	\$52	
						0	1		CWC09-01-30*	\$52	
1/2	2	3	3	7-1/2	7-1/2	1	0	12	CWC012-10-30*	\$64	
						0	1		CWC012-01-30*	\$64	
1	2	3	5	10	10	1	0	16	CWC016-10-30*	\$70	
						0	1		CWC016-01-30*	\$70	
1-1/2	3	5	7-1/2	15	15	0	0	22	CWC025-00-30*	\$80	

To complete the selection
 - Replace "*" with desired coil voltage from Coil Voltage Code Table

*AC COIL VOLTAGE CODE SELECTION				
60 Hz	24V	120V	208-240V	480V
CODE	V04	V18	V24	V47
50 Hz	20V	110V	180-208V	400-415V

Note: Other voltages available upon request.



Three Pole Miniature Contactors with DC Coil

Maximum UL Horsepower						Auxiliary Contacts		Current Rating Amps	Catalog Number	List Price	Multiplier
Single Phase		Three Phase				N.O.	N.C.				
115V	230V	200V	230V	460V	575V						
1/3	3/4	1-1/2	1-1/2	5	5	1	0	7	CWC07-10-30+	\$62	Z6
						0	1		CWC07-01-30+	\$62	
1/3	1	2	3	5	7-1/2	1	0	9	CWC09-10-30+	\$68	
						0	1		CWC09-01-30+	\$68	
1/2	2	3	3	7-1/2	7-1/2	1	0	12	CWC012-10-30+	\$74	
						0	1		CWC012-01-30+	\$74	
1	2	3	5	10	10	1	0	16	CWC016-10-30+	\$79	
						0	1		CWC016-01-30+	\$79	

To complete the selection
 - Replace "+" with desired coil voltage from Coil Voltage Code Table



+DC COIL VOLTAGE CODE SELECTION			
Vdc	24V	110V	24V LOW CONSUMPTION*
CODE	C03	C12	L03

- General Information
- Circuit Protection
- Disconnect Switches
- Motor Protectors
- Contactors
- Overloads
- Enclosed Starters
- Relays
- Pushbuttons and Pilot Lights
- Terminal Blocks
- Power Factor Correction
- Appendix A
- Appendix B

Contactors

CWC Series - Miniature Contactors

Four Pole Contactors with AC Coil

Horse Power @460V	Main Contacts		Catalog Number	List Price	Multiplier
	N.O.	N.C.			
5	4	0	CWC07-00-40*	\$48	Z6
	2	2	CWC07-00-22*		
5	4	0	CWC09-00-40*	\$52	
	2	2	CWC09-00-22*		
10	4	0	CWC016-00-40*	\$70	
	2	2	CWC016-00-22*		

To complete the selection
 - Replace "*" with desired coil voltage from Coil Voltage Code Table

*AC COIL VOLTAGE SELECTION

60 Hz	24V	120V	208-240V	480V
CODE	V04	V18	V24	V47
50 Hz	20V	110V	180-208V	400-415V



Four Pole Contactors with DC Coil

Horse Power @460V	Main Contacts		Catalog Number	List Price	Multiplier
	N.O.	N.C.			
5	4	0	CWC07-00-40+	\$62	Z6
	2	2	CWC07-00-22+		
5	4	0	CWC09-00-40+	\$68	
	2	2	CWC09-00-22+		
10	4	0	CWC016-00-40+	\$79	
	2	2	CWC016-00-22+		

To complete the selection
 - Replace "+" with desired coil voltage from Coil Voltage Code Table

+DC COIL VOLTAGE CODE SELECTION FOR CWC0_ -00-40+

60 Hz	24V	110V
CODE	C03	C12

+DC COIL VOLTAGE SELECTION FOR CWC0_ -00-22+

60 Hz	24V	110V
CODE	R03	R12



Miniature Control Relay with AC Coil

Current Rating Amps	Rating	Auxiliary Contacts			Catalog Number	List Price	Multiplier
		N.O.		N.C.			
10	A600, Q600	2		2	CWCA0-22-00*	\$45	Z6
		3		1	CWCA0-31-00*	\$45	
		4		0	CWCA0-40-00*	\$45	
		1		3	CWCA0-13-00*	\$45	
		0		4	CWCA0-04-00*	\$45	

To complete the selection

- Replace "*" with desired coil voltage from Coil Voltage Code Table

*AC COIL VOLTAGE SELECTION				
60 Hz	24V	120V	208-240V	480V
CODE	V04	V18	V24	V47
50 Hz	20V	110V	180-208V	400-415V

Note: Other voltages available upon request.



Miniature Control Relay with DC Coil

Current Rating Amps	Rating	Auxiliary Contacts			Catalog Number	List Price	Multiplier
		N.O.		N.C.			
10	A600, Q600	2		2	CWCA0-22-00+	\$59	Z6
		3		1	CWCA0-31-00+	\$59	
		4		0	CWCA0-40-00+	\$59	
		1		3	CWCA0-13-00+	\$59	
		0		4	CWCA0-04-00+	\$59	

To complete the selection

- Replace "+" with desired coil voltage from Coil Voltage Code Table

+DC COIL VOLTAGE CODE SELECTION			
Vdc	24V	110V	24V LOW CONSUMPTION*
CODE	C03	C12	L03



Contactors

CWC Series - Miniature Contactors

Front Auxiliary Contact Block

General Information

Circuit Protection

Disconnect Switches

Motor Protectors

Contactors

Overloads

Enclosed Starters

Relays

Pushbuttons and Pilot Lights

Terminal Blocks

Power Factor Correction

Appendix A

Appendix B



	For use with	Max. number of contacts/mini contactor	Auxiliary contacts		For use with CWC0 (3 pole)		For use with CWC0 (4 pole)		For use with CWCA0		List Price	Multiplier	
			NO	NC	Terminal Markings	Catalog Number	Terminal markings	Catalog Number	Terminal markings	Catalog Number			
	CWC07...16 CWCA0	2	2	0		BFC0-20		BFC4-20		BFCA-20	\$15	Z6	
			1	1		BFC0-11		BFC4-11		BFCA-11			
			0	2		BFC0-02		BFC4-02		BFCA-02			
		4	4	4	0		BFC0-40*		BFC4-40*		BFCA-40*		\$26
				2	2		BFC0-22*		BFC4-22*		BFCA-22*		
				0	4		BFC0-04*		BFC4-04*		BFCA-04*		
	3			1		BFC0-31*		BFC4-31*		BFCA-31*			
	1			3		BFC0-13*		BFC4-13*		BFCA-13*			
	CWC025	2	2	0		BFC025-20	-	-	-	-	\$15		
			1	1		BFC025-11	-	-	-	-			
			0	2		BFC025-02	-	-	-	-			

*Low consumption 24Vdc contactors can only use 2 pole auxiliary contact blocks

Mechanical Interlock Block



- Front Mounting
- Mechanical interlock without width increase
- Allows assembly of auxiliary contact blocks, surge suppressor and timing relay

For use with	Catalog Number	List Price	Multiplier
CWC07...16 CWCA0	BICO	\$10	Z6

RMCO Latch Block

	<ul style="list-style-type: none"> • Front Mounting • Mechanical interlock using 2 minicontactors (AC or DC coil) • Can be mounted with the following accessories: auxiliary contact block, surge suppressor and timers. 	For use with	Catalog Number	List Price	Multiplier
		CWC07...16 CWCA0	RMCO	\$12	Z6

Operation Description of Latch Block RMCO

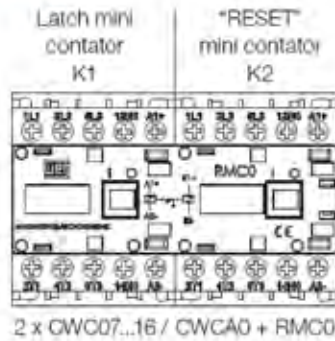

Surge suppressors

- Fast front mounting (clip on).
- Allows mounting with all the accessories.

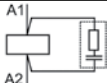
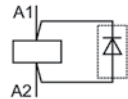
	For use with	Circuit diagram	Voltage	Catalog Number	List Price	Multiplier
	CWC07...25 CWCA0		24-48V 50/60Hz	RCC0-2 D53	\$18	Z6
			50-127V 50/60Hz	RCC0-3 D55		
			130-250V 50/60Hz	RCC0-4 D63		
			400-510V 50/60Hz	RCC0-6 D73		
			12-48VAC / 12-60VDC	VRCO-1 E49		
	50-127VAC / 60-180VDC	VRCO-2 E34				
	130-275VAC / 180-300VDC	VRCO-3 E38				
	400-510V 50/60Hz	VRCO-5 D73				
	CWC07...16 CWCA0		12-600VDC	DICO-1 C33		

Contactors

CWC Series - Miniature Contactors

Electronic timing relay

- Right-side fast mounting
- Up to 30 minutes timing
- LED status indication



Function	Time	Voltages	Catalog Number	List Price	Multiplier	
On-Delay (TECO)	3 - 0,3 to 3 seconds	24-240V 50/60Hz - DC	TECO-U003S-E05		\$150	Z6
	10 - 1 to 10 seconds		TECO-U010S-E05			
	30 - 3 to 30 seconds		TECO-U030S-E05			
	60 - 6 to 60 seconds		TECO-U060S-E05			
	100 - 10 to 100 seconds		TECO-U100S-E05			
	300 - 30 to 300 seconds		TECO-U300S-E05			
	1800 - 180 to 1800 seconds		TECO-U030M-E05			
Off-Delay (TDCO)	-	24-60V 50/60Hz - DC 100-240V 50/60Hz - DC	24-60V AC/DC	100-240V AC/DC	\$150	Z6
	3 - 0,3 to 3 seconds		TDCO-U010S-E04	TDCO-U003S-E09		
	10 - 1 to 10 seconds		TDCO-U003S-E04	TDCO-U010S-E09		
	30 - 3 to 30 seconds		TDCO-U030S-E04	TDCO-U030S-E09		
	60 - 6 to 60 seconds		TDCO-U060S-E04	TDCO-U060S-E09		
	100 - 10 to 100 seconds		TDCO-U100S-E04	TDCO-U100S-E09		
	300 - 30 to 300 seconds		TDCO-U300S-E04	TDCO-U300S-E09		
	1800 - 180 to 1800 seconds		TDCO-U030M-E04	TDCO-U030M-E09		
Start-Delta (TETCO)	30 - 3 to 30 seconds	24-28V 50/60Hz - DC	TETCO-U030S-D52		\$130	
		110-130V 50/60Hz - DC	TETCO-U030S-D61			
		220-240V 50/60Hz - DC	TETCO-U030S-D66			

Functions	On-Delay TECO	Off-Delay TDCO	Start-Delta TETCO
Functional Diagram Led On Led Off			
Diagrams			

Easy-Connection Busbar

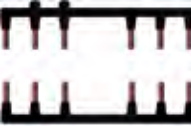
<ul style="list-style-type: none"> • Quick and easy assembly for wye-delta and reversing starters • Allows assemble of overload relay RW17D, manual motor protectors MPW18 & MPW40 and timer 					For use with	Catalog Number	List Price	Multiplier																														
					<p>Wye-Delta</p> <table border="1"> <thead> <tr> <th colspan="3">Rating (HP)</th> <th colspan="2">Contactor</th> </tr> <tr> <th>230V</th> <th>460V</th> <th>575V</th> <th>K1=K2</th> <th>K3</th> </tr> </thead> <tbody> <tr> <td>3</td> <td>7-1/2</td> <td>7-1/2</td> <td>CWC07</td> <td>CWC07</td> </tr> <tr> <td>5</td> <td>7-1/2</td> <td>10</td> <td>CWC09</td> <td>CWC07</td> </tr> <tr> <td>5</td> <td>10</td> <td>10</td> <td>CWC012</td> <td>CWC07</td> </tr> <tr> <td>7-1/2</td> <td>15</td> <td>15</td> <td>CWC016</td> <td>CWC09</td> </tr> </tbody> </table> 					Rating (HP)			Contactor		230V	460V	575V	K1=K2	K3	3	7-1/2	7-1/2	CWC07	CWC07	5	7-1/2	10	CWC09	CWC07	5	10	10	CWC012	CWC07	7-1/2	15	15	CWC016
Rating (HP)			Contactor																																			
230V	460V	575V	K1=K2	K3																																		
3	7-1/2	7-1/2	CWC07	CWC07																																		
5	7-1/2	10	CWC09	CWC07																																		
5	10	10	CWC012	CWC07																																		
7-1/2	15	15	CWC016	CWC09																																		
<p>Reversing</p> <table border="1"> <thead> <tr> <th colspan="3">Rating (HP)</th> <th colspan="2">Contactor</th> </tr> <tr> <th>230V</th> <th>460V</th> <th>575V</th> <th>K1=K2</th> <th></th> </tr> </thead> <tbody> <tr> <td>1-1/2</td> <td>5</td> <td>5</td> <td>CWC07</td> <td></td> </tr> <tr> <td>3</td> <td>5</td> <td>7-1/2</td> <td>CWC09</td> <td></td> </tr> <tr> <td>3</td> <td>7-1/2</td> <td>7-1/2</td> <td>CWC012</td> <td></td> </tr> <tr> <td>5</td> <td>10</td> <td>10</td> <td>CWC016</td> <td></td> </tr> </tbody> </table> 					Rating (HP)			Contactor		230V	460V	575V	K1=K2		1-1/2	5	5	CWC07		3	5	7-1/2	CWC09		3	7-1/2	7-1/2	CWC012		5	10	10	CWC016		ECCO-R	\$34		
Rating (HP)			Contactor																																			
230V	460V	575V	K1=K2																																			
1-1/2	5	5	CWC07																																			
3	5	7-1/2	CWC09																																			
3	7-1/2	7-1/2	CWC012																																			
5	10	10	CWC016																																			

- General Information
- Circuit Protection
- Disconnect Switches
- Motor Protectors
- Contactors
- Overloads
- Enclosed Starters
- Relays
- Pushbuttons and Pilot Lights
- Terminal Blocks
- Power Factor Correction
- Appendix A
- Appendix B

Contactors

CWC Series - Miniature Contactors

Technical Data

General Data

Catalog Number			CWCA0	CWC07	CWC09	CWC012	CWC016	CWC025
Standards			IEC 60947 / UL 508					
Rated insulation voltage U_i (pollution degree 3)	IEC/EN 60947-4-1, VDE 0660	(V)	690					
	UL, CSA	(V)	600					
Rated impulse withstand voltage U_{imp} (IEC/EN 60947-1)		(kV)	4					
Rated operational frequency		(Hz)	25...400					
Mechanical lifespan	AC coil Ops x 10 ⁶ "		10					3
	DC coil Ops x 10 ⁶ "		12					-
Electrical lifespan		le AC-3 Ops x 10 ⁶ "	-	1.4	1.3	1.2	1.1	0.6
Degree of protection (VDE 0160)	Main circuits		IP20					
	Control circuits and auxiliary contacts		IP20					
Mounting			Screw or DIN rail 35 mm					
Coil terminals			2					
Vibration resistance	Contacteur open	(g)	2					
	Contacteur closed	(g)	4					
Mechanical shock resistance (½ sinusoid = 11 ms)	Contacteur open	(g)	6					
	Contacteur closed	(g)	10					
Ambient temperature	Operation		-25 °C ... +55 °C					
	Storage		-55 °C ... +80 °C					
Normal values			Up to 3,000 m					
Altitude	90% le / 80% Ue		3,000 to 4,000 m					
	80% le / 75% Ue		4,000 to 5,000 m					

Control Circuit - Alternating Current (AC)

Catalog Number			CWCA0, CWC07...16		CWC025
Rated insulation voltage U_i (pollution degree 3)	IEC/EN 60947-4-1, VDE 0660	(V)	1,000		1,000
	UL, CSA	(V)	600		600
Coils rated voltage 50 Hz		(V)	10...550		10...550
Coils rated voltage 60 Hz		(V)	12...660		12...660
Coils rated voltage 50/60 Hz		(V)	12...660		12...660
Coils rated voltage					
Coil operating limits		(xUs)	0.85...1.1		
Coil 60 Hz	Pick up	(xUs)	0.4...0.76		0.4...0.76
	Drop out	(xUs)	0.25...0.65		0.25...0.65
Coil 50/60 Hz	Pick up	(xUs)	0.5...0.8		0.5...0.8
	Drop out	(xUs)	0.2...0.6		0.2...0.6
Average consumption			1.0 x Us coil cold state		
Coil 60 Hz	Magnetic circuit closed	(VA)	2.5...3.5		10.8...13.2
	Power factor	(cos φ)	0.28		0.32
	Power dissipation per pole	(W)	2.6		-
	Magnetic circuit closing	(VA)	35		72
	Power factor	(cos φ)	0.85		0.93
Coil 50/60 Hz	Magnetic circuit closed	(VA)	2...3		4.56...5.8
	Magnetic circuit closing	(VA)	30		58
Average time	Closing NO contacts	(ms)	8...20		13...16
	Opening NO contacts	(ms)	6...13		13.5...17

Control Circuit - Direct Current (DC)

Catalog Number			CWCA0, CWC07...16		CWC07...16
Coil type			Conventional	Low consumption	4P (2P/2R)
Rated insulation voltage U_i (pollution degree 3)	IEC/EN 60947-4-1, VDE 0660	(V)	1,000		
	UL, CSA	(V)	600		
Standard voltages		(V)	12...440		
Coil operating limits		(xUs)	0.85...1.1		
	Pick up	(xUs)	0.4...0.7		
	Drop out	(xUs)	0.15...0.4		
Power consumption			1.0 x Us coil cold state		
	Magnetic circuit closed	(W)	2.6...3.7		2.9...4
	Magnetic circuit closing	(W)	2.6...3.7		2.9...4
Operation time	Closing NO contacts	(ms)	35...45		
	Opening NO contacts	(ms)	7...12		

Technical Data

Power Circuit

Catalog Number			CWC07	CWC09	CWC012	CWC016	CWC025	
Rated operational current I_o	AC-3 ($U_e \leq 440$ V)	(A)	7	9	12	16	22	
	AC-4 ($U_e \leq 440$ V)	(A)	2.8	3.5	4.5	5	9	
	AC-1 ($\theta \leq 55$ °C, $U_e \leq 690$ V)	(A)	18	20	22	22	32	
Rated operational voltage U_e	IEC/EN 60947-4-1, VDE 0660	(V)	690					
	UL, CSA ¹⁾	(V)	600					
Rated thermal current I_{th} ($\theta \leq 55$ °C)	(A)	18	20	22	22	32		
Making capacity - IEC/EN 60947	(A)	70	90	120	160	250		
Breaking capacity IEC/EN 60947	($U_e \leq 400$ V)	(A)	50	72	96	128	200	
	($U_e = 500$ V)	(A)	50	72	96	128	200	
	($U_e = 690$ V)	(A)	35	54	72	96	150	
Short-time current (no current flowing during recovery time of 10 min and $\theta \leq 40$ °C)	1 seg	(A)	250	250	250	250	-	
	5 seg	(A)	125	125	125	125	-	
	10 seg	(A)	95	95	95	95	-	
	30 seg	(A)	70	70	70	70	-	
	1 min	(A)	50	50	50	50	-	
	3 min	(A)	40	40	40	40	-	
Protection against short-circuits with fuses (gL/gG)	@600 V - UL/CSA ¹⁾	(kA)	5					
	Coordination type 1	(A)	35	35	35	35	50	
	Coordination type 2	(A)	20	20	25	25	35	
Average impedance per pole	(m Ω)	6	6	5	5	6		
Average power dissipation per pole	AC-1	(W)	1.9	2.4	2.4	2.4	6.1	
	AC-3	(W)	0.3	0.5	0.7	1.3	3.8	
Utilization category								
Rated operational current I_e ($\theta \leq 55$ °C)	$U_e \leq 440$ V	(A)	7	9	12	16	22	
	$U_e \leq 500$ V	(A)	6.2	7.5	8.8	13	16	
	$U_e \leq 690$ V	(A)	4.5	5.5	6.6	10	13	
	$U_e \leq 1,000$ V	(A)	Not available					
Rated operational power ¹⁾	220 / 230 V	(kW)	1.5	2.2	3	3.7	5.5	
		(cv)	2	3	4	5	7.5	
	380 / V	(kW)	3	3.7	5.5	7.5	11	
		(cv)	4	5	7.5	10	15	
	400 / 415 V	(kW)	3	3.7	5.5	7.5	11	
		(cv)	4	5	7.5	10	15	
	440 V	(kW)	3.7	4.5	5.5	7.5	11	
		(cv)	5	6	7.5	10	15	
	500 V	(kW)	3.7	4.5	5.5	7.5	11	
		(cv)	5	6	7.5	10	15	
	660 / 690 V	(kW)	3	3.7	5.5	7.5	11	
		(cv)	4	5	7.5	10	15	
Max. electrical operational per hour	600 ops./h	(%)	100	100	100	100	100	
	1,200 ops./h	(%)	75	75	75	75	75	
	3,000 ops./h	(%)	50	50	50	50	50	
Utilization category AC-4								
Rated operational current I_o AC-4 ($U_e \leq 440$ V)			(A)	2.8	3.5	4.5	5	9
Rated operational power ¹⁾ (200,000 operations)	220 / 230 V	(kW)	0.55	0.75	0.75	1.1	2.2	
		(cv)	0.7	1	1	1.5	2.9	
	380 / 400 V	(kW)	1.1	1.1	1.8	2.2	4	
		(cv)	1.5	1.5	2.4	2.9	5.4	
	415 V	(kW)	1.1	1.5	2.2	2.2	4.5	
		(cv)	1.5	2	2.9	2.9	6	
	440 V	(kW)	1.1	1.5	2.2	2.2	4.5	
		(cv)	1.5	2	2.9	2.9	6	
	500 V	(kW)	1.1	1.5	2.2	2.2	4.5	
		(cv)	1.5	2	2.9	2.9	6	
	660 / 690 V	(kW)	1.1	1.5	2.2	2.2	4.5	
		(cv)	1.5	2	2.9	2.9	6	

Note: 1) For 50/60 Hz three-phase, 4 poles WEG standard motors. These values are only for reference and may change on the number of poles and motor design.

Contactors

CWC Series - Miniature Contactors

Technical Data

Power Circuit

Catalog Number			CWC07	CWC09	CWC012	CWC016	CWC025
			Utilization category AC-1				
			3P (NO) or 4P (4NO)				3P (NO)
Rated thermal current I_{th} ($\theta \leq 55^\circ\text{C}$)	(A)		18	20	22	22	32
Maximum operational current (up to 690 V)	$\theta \leq 40^\circ\text{C}$	(A)	18	20	22	22	32
	$\theta \leq 55^\circ\text{C}$	(A)	18	20	22	22	32
	$\theta \leq 70^\circ\text{C}$	(A)	14.4	16	17.6	17.6	25.6
Maximum operational power $\theta \leq 55^\circ\text{C}$ 3-phase resistors	220 / 230 V	(kW)	6.8	7.5	8.3	8.3	12
	380 / 400 V	(kW)	11.5	13	14.5	14.5	21
	415 / 440 V	(kW)	13	14.5	16	16	23
	500 V	(kW)	14.8	16.5	18	18	26
Current values for connection of	2 poles in parallel		$I_e \times 1.7$				
	3 poles in parallel		$I_e \times 2.4$				
	4 poles in parallel		$I_e \times 3.2$				
Percentage of the max. operational current at	600 ops./h	(%)	100				
	1,200 ops./h	(%)					
	3,000 ops./h	(%)					
Maximum operational power $\theta \leq 55^\circ\text{C}$ (resistive load)			2P (NO/NC) or 4P (2NO + 2NC)				2P (NO/NC)
	220 / 230 V	(kW)	3.9	4.4	4.8	4.8	6.6
	380 / 400 V	(kW)	6.8	7.6	8.4	8.4	11.4
	415 / 440 V	(kW)	7.5	8.4	9.2	9.2	12.5
	500 V	(kW)	8.6	9.5	10.5	10.5	14.5
660 / 690 V	(kW)	11.8	13.1	14.4	14.4	19.5	

UL Power Ratings

Catalog Number			CWC07	CWC09	CWC012	CWC016	CWC025
General purpose current	(600 V)	(A)	18	20	22	22	30
1-phase	110 / 120 V	(HP)	1/3	1/3	1/2	1	1 1/2
	208 V	(HP)	3/4	1/2	1/2	2	3
	220 / 240 V	(HP)	3/4	1/2	2	2	3
3-phase	110 / 120 V	(HP)	3/4	1	1 1/2	2	3
	200 V	(HP)	1 1/2	2	3	3	5
	220 / 240 V	(HP)	1 1/2	3	3	5	7 1/2
	440 / 480 V	(HP)	5	5	7 1/2	10	15
	550 / 600 V	(HP)	5	7 1/2	7 1/2	10	15

Built-In Auxiliary Contacts

Catalog Number			CWC07...16		CWCA0
Standards			IEC 60947-5-1, IEC 60947-4-1		
Rated insulation voltage U_i (pollution degree 3)	IEC, VDE 0660	(V)	690		
	UL, CSA	(V)	600		
Rated operational voltage U_e	IEC, VDE 0660	(V)	690		
	UL, CSA	(V)	600		
Rated thermal current I_{th} ($\theta \leq 55^\circ\text{C}$)		(A)	10		
Rated operational current I_e					
AC-15 (IEC 60947-5-1)	$U_e \leq 240\text{ V}$	(A)	10		
	380-400 V	(A)	6		
	415-440 V	(A)	5		
	500 V	(A)	4		
	660-690 V	(A)	2		
UL, CSA			A600		
DC-13 (IEC 60947-5-1)	24 V	(A)	6		
	48 V	(A)	4		
	110 V	(A)	2		
	220 V	(A)	0.7		
UL, CSA			Q600		
Making capacity (rms)	$U_e \leq 400\text{ V } 50/60\text{ Hz - AC-15}$	(A)	$10 \times I_e$ (AC-15)		
Breaking capacity (rms)	$U_e \leq 400\text{ V } 50/60\text{ Hz - AC-15}$	(A)	$10 \times I_e$ (AC-15)		
Max.fuse class gL-gG without welding (short-circuit protection) gL/gG		(A)	10		
Control circuit reliability	(V / mA)		17 / 5		
Electrical endurance	(millions operations)		1		
Mechanical endurance	(millions operations)		10		

Technical Data

Auxiliary Contacts

Catalog Number		BFC0 / BFC025	
Standards		IEC 60947-5-1, IEC 60947-4-1	
Rated insulation voltage U_i (pollution degree 3)	IEC, VDE 0660 (V)	1,000	
	UL, CSA ¹⁾ (V)	600	
Rated operational voltage U_e	IEC, VDE 0660 (V)	690	
	UL, CSA ¹⁾ (V)	600	
Rated thermal current I_{th} ($\theta \leq 55$ °C) (A)		10	
Rated operational current I_e			
AC-15 (IEC 60947-5-1)	$U_e \leq 240$ V (A)	10	
	380-400 V (A)	6	
	415-440 V (A)	6	
	500 V (A)	4	
	660-690 V (A)	-	
UL, CSA ¹⁾		A600	
DC-13 (IEC 60947-5-1)	24 V (A)	1.5	
	60 V (A)	0.5	
	110 V (A)	0.4	
	220-240 V (A)	0.4	
UL, CSA ¹⁾		Q600	
Making capacity (rms)	$U_e \leq 400$ V 50/60 Hz - AC-15 (A)	30	
Breaking capacity (rms)	$U_e \leq 400$ V 50/60 Hz - AC-15 (A)	3	
Max.fuse class gL-gG without welding (short-circuit protection) (A)		10	
Control circuit reliability	(V / mA)	17 / 5	
Electrical endurance	(millions operations)	1	
Mechanical endurance	(millions operations)	10	

Timing relay

Rated insulation voltage (U_i)	V	300	
Supply voltage (U_e)	1 - 2 terminals	24...240 V dc/ V ac 50/60 Hz (TECO)	
		24...60 V dc/ V ac 50/60 Hz (TDCO)	
		100...240 V dc/ V ac 50/60 Hz (TDCO)	
		220-240 V ac 50/60 Hz (TETCO)	
		110-130 V ac 50/60 Hz (TETCO)	
		24-28 V ac 50/60 Hz (TETCO)	
Control voltage (U_c) only TDCO - pag A25	2 - B1 terminals	24...60 V dc/ V ac 50/60 Hz (TDCO)	
		100...240 V dc/ V ac 50/60 Hz (TDCO)	
Voltage operational limits		0.85...1.1 x U_c (V ac)	
		0.8...1.25 x U_c (V dc)	
Consumption	mA	≤ 5	
Minimum time for reset (recovery time)	ms	650	
Minimum control time (only TDCO)	ms	50	
Setting accuracy (% of the full scale value)	%	+/-5	
Repeat accuracy	%	+/-1	
Changeover time $Y - \Delta$	ms	50	

Contactors

CWC Series - Miniature Contactors

Technical Data

Terminal Capacity and Tightening Torque - Power and Built-In Auxiliary Terminals

Catalog Number	CWC07...CWC016 / CWCA0			CWC025		
Screw type	M3x 8 Flat / Phillips			M3.5x 9 Flat / Phillips		
Power terminal and built-in auxiliary terminal ¹⁾	Finely stranded with end sleeve	Stranded and finely stranded without end sleeve	Solid	Finely stranded with end sleeve	Stranded and finely stranded without end sleeve	Solid
mm ²	1x 0.5...2.5 2x 0.5...1.5	1x 0.75...2.5 2x 0.75...2.5	1x 0.5...2.5 2x 0.5...2.5	1x 1...6 2x 1...2.5 2x 2.5...4	1x 1...6 2x 1...2.5 2x 2.5...6	1x 1...6 2x 1...2.5 2x 2.5...6
AWG (UL)	18...12			18...10		
Tightening torque (N.m)	1.1			1.5		
Tightening torque (lb.in) (UL)	10			13		

Note: 1) Built-in auxiliary terminals not available for CWC025.

Terminal Capacity and Tightening Torque - Coil Terminals

Catalog Number	CWC07...CWC025 / CWCA0		
Screw type	M3.5x 8 Flat / Phillips		
Coil terminals	Finely stranded with end sleeve	Stranded and finely stranded without end sleeve	Solid
mm ²	1x 0.5...2.5 2x 0.5...1.5	1x 0.75...2.5 2x 0.75...2.5	1x 0.5...2.5 2x 0.5...2.5
AWG (UL)	22...12		
Tightening torque (N.m)	1.1		
Tightening torque (lb.in) (UL)	10		

Terminal Capacity and Tightening Torque - Auxiliary Contact Blocks

Catalog Number	BFC0 / BFCA / BFC4 / BFC025		
Screw type	M3.5x9 Flat / Phillips		
Auxiliary contact block	Finely stranded with end sleeve	Stranded and finely stranded without end sleeve	Solid
mm ²	1x 0.5...2.5 2x 0.5...1.5	1x 0.75...4 2x 0.75...2.5	1x 0.5...4 2x 0.5...2.5
AWG (UL)	22...14		
Tightening torque (N.m)	1.1		
Tightening torque (lb.in) (UL)	10		

Terminal Capacity - Power, Coil and Auxiliary Contact Blocks

Catalog Number	CWC07_S... CWC012_S / CWCA0_S		BFC0_S / BFCA_S / BFC4_S
Terminal type	Spring terminal		
Power terminal	Finely stranded with end sleeve	Solid	
mm ²	2x 1...1.5	2x 1...1.5	
Auxiliary contact block / built-in auxiliary terminal / or coil terminal	Finely stranded with end sleeve	Solid	Solid or finely stranded with end sleeve
mm ²	2x 0.5...1.5	2x 0.5...1.5	2x 0.5...1.5
AWG	18...12		22...16

Technical Data

Utilization Category DC-1, DC-3 and DC-5
DC-1(L/R ≤ 1ms)

U _e	Catalog Number	CWC07	CWC09	CWC012	CWC016	CWC025
	Serie poles	Rated operational current I _e (A)				
≤ 24 V	1	10	10	16	16	18
	2	15	15	20	20	25
	3	15	15	22	22	25
	4	15	15	22	22	-
≤ 48 V	1	10	10	13	13	16
	2	15	15	20	20	25
	3	15	15	22	22	25
	4	15	15	22	22	-
≤ 60 V	1	8	8	10	10	13
	2	15	15	18	18	25
	3	15	15	22	22	25
	4	15	15	22	22	-
≤ 125 V	1	4	4	5	5	6
	2	8	8	10	10	13
	3	12	12	16	16	18
	4	15	15	19	19	-
≤ 220 V	1	0.6	0.6	0.7	0.7	1
	2	5	5	6	6	8
	3	9	9	10	10	14
	4	12	12	15	15	-
≤ 440 V	1	0.2	0.2	0.3	0.3	0.4
	2	0.6	0.6	0.7	0.7	1.5
	3	3.5	3.5	4	4	5
	4	8	8	9	9	-
≤ 600 V	1	-	-	-	-	-
	2	0.2	0.2	0.3	0.3	0.6
	3	1	1	1.5	1.5	2
	4	2	2	4	4	-

DC-3(L/R ≤ 2.5ms)

U _e	Catalog Number	CWC07	CWC09	CWC012	CWC016	CWC025
	Serie poles	Rated operational current I _e (A)				
≤ 24 V	1	9	9	9	9	10
	2	12	12	12	12	15
	3	15	15	15	15	18
	4	15	15	15	15	-
≤ 48 V	1	8	8	8	8	10
	2	12	12	12	12	15
	3	15	15	15	15	18
	4	15	15	15	15	-
≤ 60 V	1	5	5	5	5	8
	2	10	10	10	10	13
	3	14	14	14	14	18
	4	15	15	15	15	-
≤ 125 V	1	1.5	1.5	1.5	1.5	2
	2	5.5	5.5	5.5	5.5	7
	3	10	10	10	10	13
	4	14	14	14	14	-
≤ 220 V	1	0.4	0.4	0.4	0.4	0.6
	2	1.5	1.5	1.5	1.5	2
	3	7	7	7	7	8
	4	11	11	11	11	-
≤ 440 V	1	-	-	-	-	-
	2	0.2	0.2	0.2	0.2	0.3
	3	1	1	1	1	1.5
	4	3	3	3	3	-
≤ 600 V	1	-	-	-	-	-
	2	-	-	-	-	-
	3	0.6	0.6	0.6	0.6	0.8
	4	1.5	1.5	1.5	1.5	-

DC-5(L/R ≤ 15ms)

U _e	Catalog Number	CWC07	CWC09	CWC012	CWC016	CWC025
	Serie poles	Rated operational current I _e (A)				
≤ 24 V	1	1.5	8	8	8	10
	2	2.5	12	12	12	14
	3	3	15	15	15	18
	4	3	15	15	15	-
≤ 48 V	1	1.5	8	8	8	9
	2	2.5	12	12	12	14
	3	3	15	15	15	18
	4	3	15	15	15	-
≤ 60 V	1	1.2	5	5	5	7
	2	2.5	10	10	10	12
	3	3	14	14	14	18
	4	3	15	15	15	-
≤ 125 V	1	0.7	1.5	1.5	1.5	0.8
	2	1.5	5.5	5.5	5.5	5
	3	2.5	9	9	9	12
	4	3	14	14	14	-
≤ 220 V	1	0.1	0.4	0.4	0.4	-
	2	0.5	0.7	0.7	0.7	0.8
	3	1.5	2.5	2.5	3	3
	4	2.2	9	9	9	-
≤ 440 V	1	-	-	-	-	-
	2	-	-	-	-	-
	3	0.1	0.3	0.3	0.3	0.5
	4	0.3	0.7	0.7	0.7	-
≤ 600 V	1	-	-	-	-	-
	2	-	-	-	-	-
	3	-	-	-	-	-
	4	-	0.2	0.2	0.2	-

1 serie pole



2 serie poles

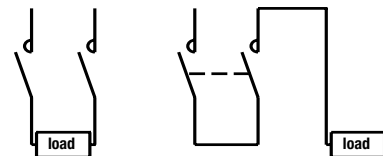

3 serie poles

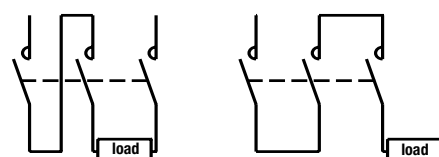

4 serie poles

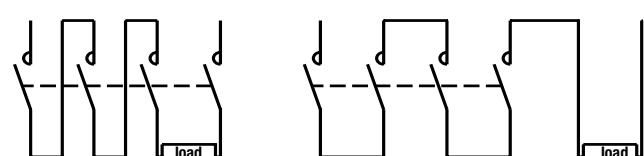

Contactors

CWC Series - Miniature Contactors

Technical Data

Timing relay

Rated insulation voltage (U _i)	V	300
Supply voltage (U _e)	1 - 2 terminals	24...240 V dc/ V ac 50/60 Hz (TECO)
		24...60 V dc/ V ac 50/60 Hz (TDC0)
		100...240 V dc/ V ac 50/60 Hz (TDC0)
		220-240 V ac 50/60 Hz (TETCO)
		110-130 V ac 50/60 Hz (TETCO)
Control voltage (U _c) only TDC0 - pg A25	2 - B1 terminals	24...60 V dc/ V ac 50/60 Hz (TDC0)
		100...240 V dc/ V ac 50/60 Hz (TDC0)
Voltage operational limits		0.85...1.1 x U _c (V ac)
		0.8...1.25 x U _c (V dc)
Consumption	mA	≤ 5
Minimum time for reset (recovery time)	ms	650
Minimum control time (only TDC0)	ms	50
Setting accuracy (% of the full scale value)	%	+/-5
Repeat accuracy	%	+/-1
Changeover time Y - Δ	ms	50

Operation Description of Latch Block RMC0 or Miniature Contactors CWCH0

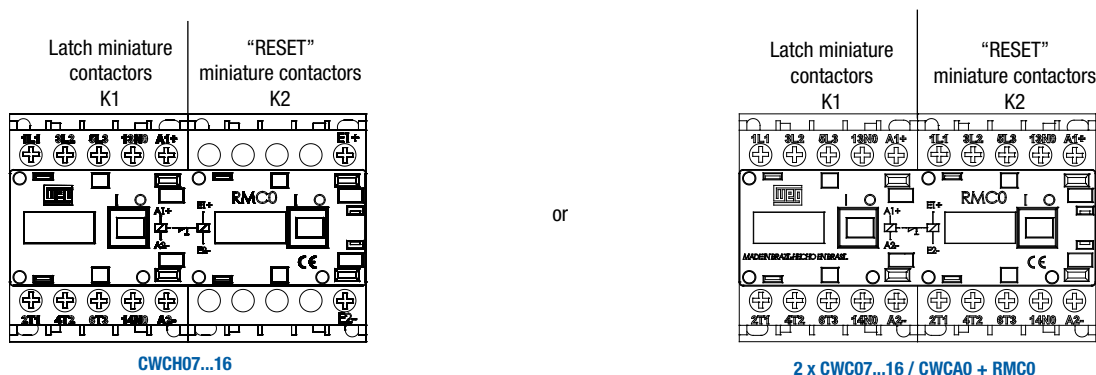

Functional Diagram

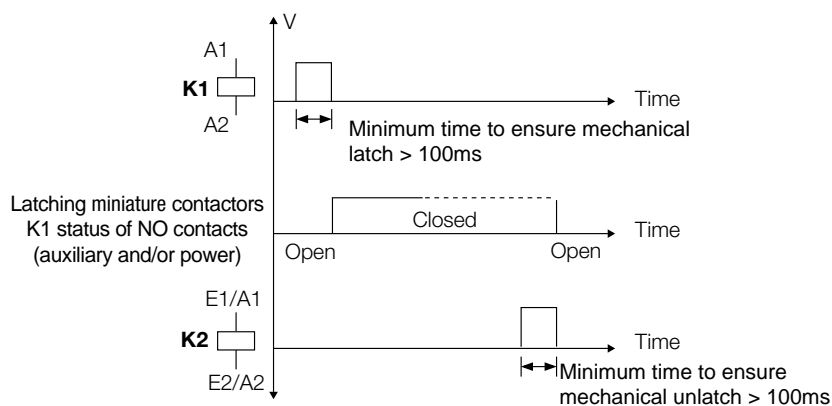

- After a minimum pulse of 100ms on miniature contactors coil (K1), the RMC0 will keep K1 contacts switched on
- The miniature contactors K1 will only return to rest position after miniature contactors coil (K2) be energized by a releasing pulse
- The mechanical latch will always and only happen on miniature contactors (K1).

Note: if RESET miniature contactors coil (K2) remains energized, the latching of miniature contactors (K1) is not enabled.

Technical Data

Electrical Lifespan

AC-3 ($U_e \leq 415 \text{ V ac}$ e $U_e \leq 440 \text{ V ac}$)

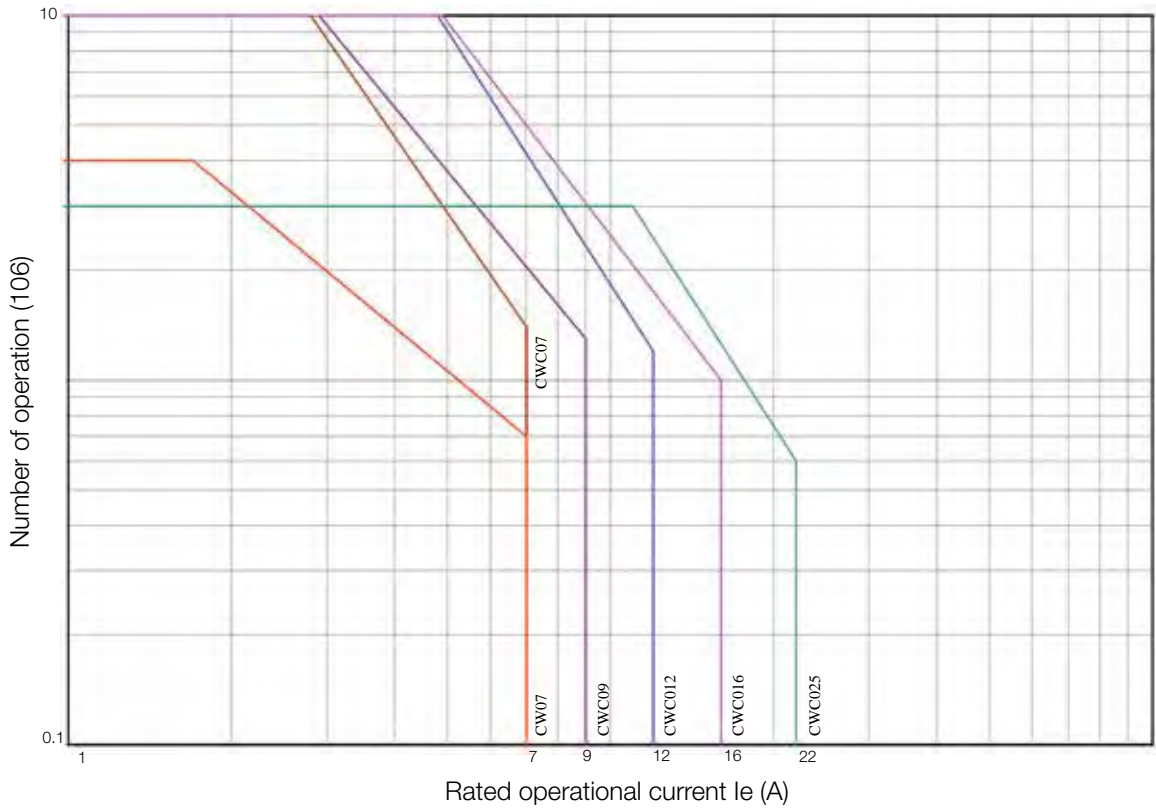

AC-4 ($U_e \leq 440 \text{ V ac}$)

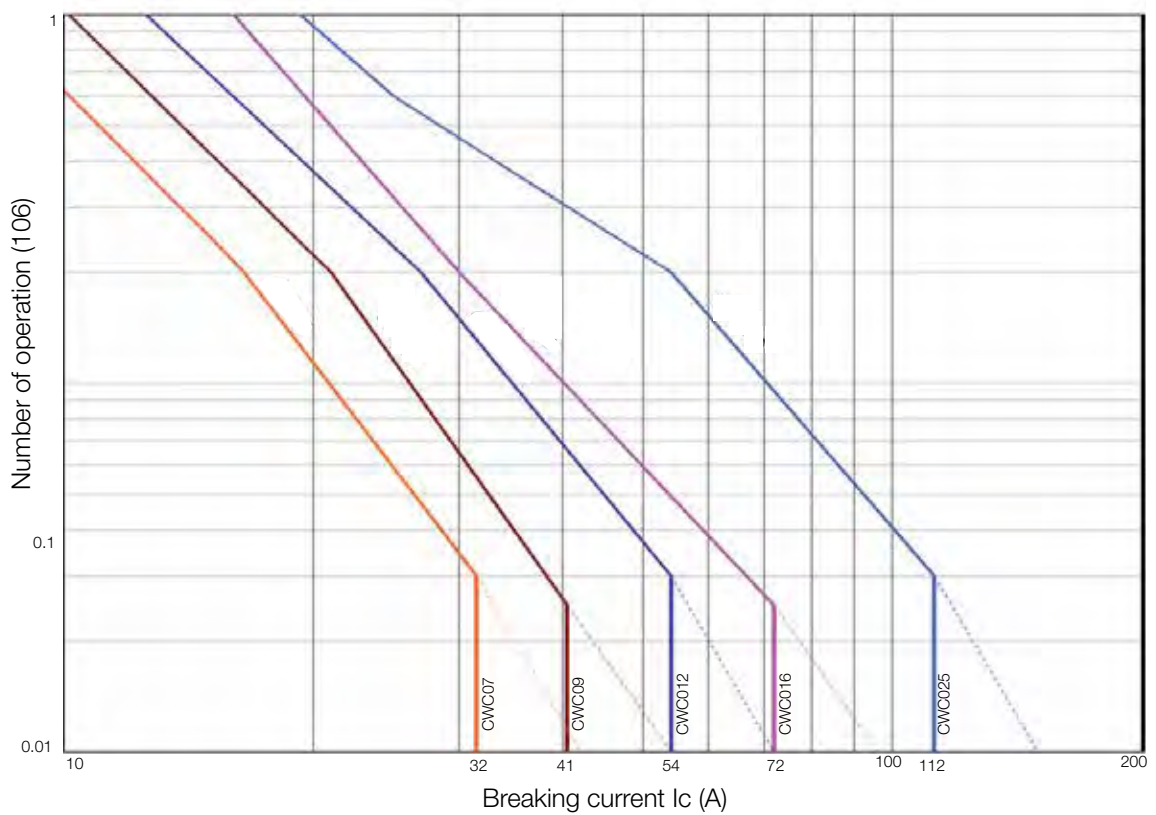

Contactors

CWC Series - Miniature Contactors

Dimensions mm (in)

CWC07...016 AND CWCA0

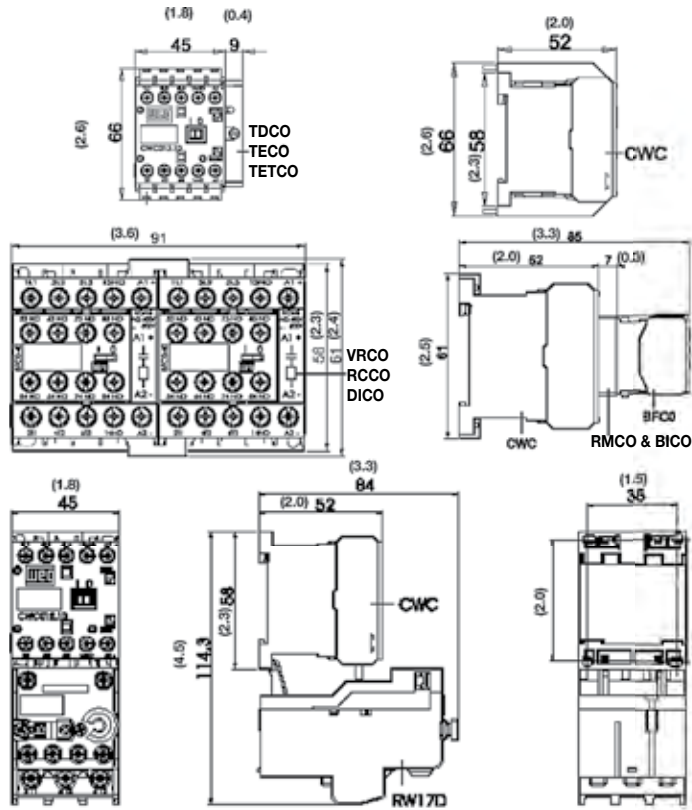

CWC025

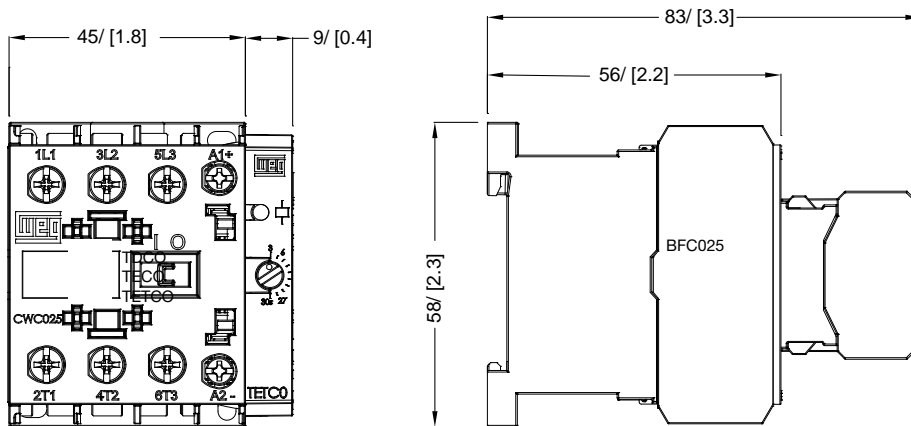

General Information

Circuit Protection

Disconnect Switches

Motor Protectors

Contactors

Overloads

Enclosed Starters

Relays

Pushbuttons and Pilot Lights

Terminal Blocks

Power Factor Correction

Appendix A

Appendix B

CWB Line

Developed according to IEC 60947 and UL 508 international standards, the new WEG CWB line of contactors meets the requirements of a wide range of industrial applications. The CWBs are designed with the visual pattern and identity of WEG, a brand recognized worldwide for its quality.

Standard Features:

- “Zero-Width” Mechanical Interlock
- Simple and Compact Mounting of Surge Suppressor Blocks
- Contactor Coil Operated on AC or DC
- Simple and Organized Control Circuits
- Additional Contact Blocks
- Easy Access Power and Control Terminals



UL File No. E202315

CWB Contactor Catalog Number Sequence

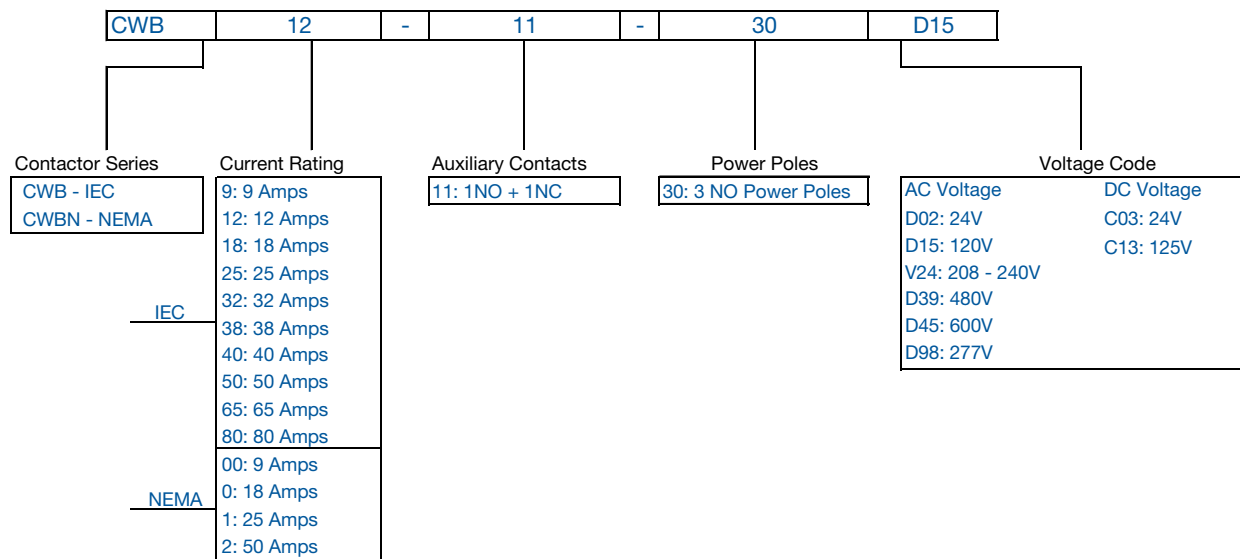

Table intended as reference only and not to create part numbers.

- General Information
- Circuit Protection
- Disconnect Switches
- Motor Protectors
- Contactors
- Overloads
- Enclosed Starters
- Relays
- Pushbuttons and Pilot Lights
- Terminal Blocks
- Power Factor Correction
- Appendix A
- Appendix B

CWB Series

Selection Table

Three-Pole CWB Contactors from 9 A to 80 A (AC-3)

le máx. (Ue ≤440 V)	Maximum UL Horsepower						Built-in auxiliary contacts per contactor		Catalog Number	List Price AC Coil	List Price DC Coil	Multiplier
	Single Phase		Three Phase									
	115V	230V	200V	230V	480V	575V						
AC-3 A												
9	3/4	1.5	3	3	5	7 1/2	1	1	CWB9-11-30*	\$84.50	\$88	Z1
12	3/4	2	3	3	7 1/2	10	1	1	CWB12-11-30*	\$89	\$103	
18	1	3	5	5	10	15	1	1	CWB18-11-30*	\$103	\$123.50	
25	2	5	7 1/2	7 1/2	15	15	1	1	CWB25-11-30*	\$118	\$128	
32	3	5	10	10	20	25	1	1	CWB32-11-30*	\$140	\$180	
38	3	7.5	10	10	25	25	1	1	CWB38-11-30*	\$164	\$198	
40	3	7 1/2	10	15	30	30	1	1	CWB40-11-30*	\$164	\$215	
50	3	10	15	15	40	40	1	1	CWB50-11-30*	\$225	\$310	
65	5	10	20	20	50	50	1	1	CWB65-11-30*	\$255	\$350	
80	7 1/2	15	20	25	50	60	1	1	CWB80-11-30*	\$270	\$417	

Three-Pole CWB NEMA Rated Sizes 00 - 2

NEMA Size	Maximum UL Horsepower						Built-in auxiliary contacts per contactor		Catalog Number	List Price AC Coil	List Price DC Coil	Multiplier
	Single Phase		Three Phase									
	115V	230V	200V	230V	480V	575V						
00	1/3	1	1.5	1.5	2	2	1	1	CWBN00-11-30*	\$103	\$150	Z1
0	1	2	3	3	5	5	1	1	CWBN0-11-30*	\$118	\$177	
1	2	3	7 1/2	7 1/2	10	10	1	1	CWBN1-11-30*	\$164	\$220	
2	3	7.5	10	15	25	25	1	1	CWBN2-11-30*	\$233	\$330	

Replace "*" by the appropriate coil voltage code.

Alternating Current

Code	D02	D15	V24	D39	D45	D98
V (50/60 Hz)	24	120	180-208V 50Hz 208-240V 60Hz	480	600	277

Direct Current

Code	C03	C07	C13
V dc	24	48	125

Notes:

1) Other voltages on request

Accessories and Spare Parts

Front Mounted Auxiliary Contact Blocks⁴⁾

	For use with	Max. n° of additional contacts / contactor	Auxiliary contacts		Catalog Number	List Price	Multiplier
			NO	NC			
 .063 kg	CWB9...80 CWBN00-2	4 / CWB9...38 4 / CWB40...80 4 / CWBN00...2	1	1	BFB-11 ¹⁾	\$20	Z1
			2	0	BFB-20	\$20	
			0	2	BFB-02 ¹⁾	\$20	
			2	2	BFB-22 ¹⁾	\$32	
			2	2	BFB-22 EL ³⁾	\$32	
			4	0	BFB-40	\$32	
			0	4	BFB-04 ¹⁾	\$32	
			3	1	BFB-31 ¹⁾	\$32	
			1	3	BFB-13 ¹⁾	\$32	

Side Mounted Auxiliary Contact Blocks⁴⁾

	For use with	Max. n° of additional contacts / contactor	Auxiliary contacts		Catalog Number	List Price	Multiplier
			NO	NC			
 .034 kg	CWB9...80 CWBN00-2	4 / CWB9...38 4 / CWB40...80 4 / CWBN00...2	1	1	BLB-11 ¹⁾	\$22	Z1
			2	0	BLB-20		
			0	2	BLB-02 ¹⁾		
			1	1	BLRB-11 ¹⁾²⁾		
			2	0	BLRB-20 ²⁾		
			0	2	BLRB-02 ¹⁾²⁾		

Plug-In Surge Suppressors

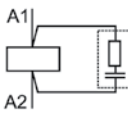
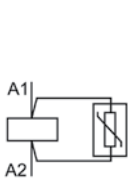
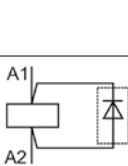
	For use with	Voltage	Diagram	Catalog Number	List Price	Multiplier
 .008 kg	CWB9...80 CWBN00...2	24...48 V 50/60 Hz		RCB D53	\$30	Z1
		50...127 V 50/60 Hz		RCB D55		
		130...250 V 50/60 Hz		RCB D63		
		12-48VAC / 12-60VDC		VRB E49		
		50-127VAC / 60-180VDC		VRB E34		
		130-250VAC / 180-300VDC		VRB E50		
		277-380VAC / 300-510VDC		VRB E41		
		400...510 V 50/60 Hz		VRB D73		
		12...600 V dc		DIB C33		
		12...250 V dc		DIZB C26		

Notes: 1) The arrangement of the contacts meets IEC 60947-4-1 Annex F (Mirror Contact) and IEC 60947-5-1 Annex L (Mechanically Linked Contact) requirements.
 2) For combination of 2 side-mounted auxiliary contact blocks at the same side of the contactor.
 3) BFB-22-EL: besides the regular contacts NO and NC, there are two special contacts: early make and late break.
 4) The maximum number of auxiliary contacts assembled on the contactor are 4.

CWB Series

Accessories and Spare Parts

Mechanical Interlock

Image	For use with	Description	Catalog Number	List Price	Multiplier
	CWB9...38 CWBN00...1	Mounting set for interlocking two contactors with the same frame type. Fitting through snaps without tools.	IM1	\$12	Z1
	CWB40...80 CWBN2		IM2	\$15	

Easy-Connection Setting of the Power Terminals for Reversing Starters

Image	For use with		Orientative rated operational power for reversing starters (AC-4 duty) for three-phase 4-pole motors - 60 Hz - 1,800 rpm		Catalog Number	List Price	Multiplier
	K1=K2		230 V kW / cv	400 V kW / cv			
	CWB9/CWBN00		1.5 / 2.0	2.2 / 2.9	EC-R1	\$60	Z1
	CWB12		1.5 / 2.0	3.7 / 5.0			
	CWB18/CWBN0		2.2 / 2.9	4 / 5.4			
	CWB25/CWBN1		3 / 4.0	5.5 / 7.4			
	CWB32		4 / 5.4	7.5 / 10.1			
	CWB38		4 / 5.4	7.5 / 10.1			
	CWB40		4.5 / 6.0	9.2 / 12.3	EC-R2	\$75	
	CWB50/CWBN2		5.5 / 7.4	11 / 14.7			
	CWB65		7.5 / 10.1	15 / 20.1			
	CWB80		11 / 14.7	18.5 / 24.8			

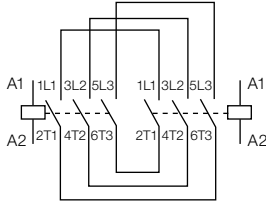
Electric diagram

Power Terminal Easy-Connection Set for Star-Delta Starters

Image	For use with		Orientative rated operational power in AC-3 Three-phase motor - IV poles - 1,800 rpm		Catalog Number	List Price	Multiplier
	K1=K2	K3	230 V kW / cv	400 V kW / cv			
	CWB9	CWB9	4 / 5.4	7.5 / 10	EC-SD1	\$75	Z1
	CWB12	CWB9	5.5 / 7.5	11 / 15			
	CWB18	CWB12	9.2 / 12.5	15 / 20			
	CWB25	CWB18	11 / 15	22 / 30			
	CWB32	CWB18	15 / 20	-			
	CWB38	CWB25	18.5 / 25	30 / 40			
	CWB50	CWB40	22 / 30	45 / 61	EC-SD2	\$90	
	CWB65	CWB40	30 / 40	55 / 75			
	CWB80	CWB50	45 / 61	75 / 102			

Electric diagram

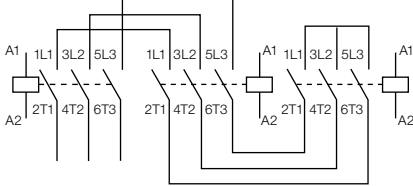
Accessories and Spare Parts

Spare Coils for Contactors¹⁾

Image	For use with	Control type	Reference to fill in with the control voltage	List Price	Multiplier
	CWB9...38 CWBN00...1	AC	BRB-38◆	\$22	
	CWB40...80 CWBN2	AC	BRB-80◆	\$40	Z1
	CWB40...80 CWBN2	DC	BRB-80◆	\$110	

Replace “◆” by the appropriate coil voltage code.

To complete the Part Number, replace “◆” by the appropriate coil voltage code.

Alternating Current

Coil voltage code	D02	D15	V24	D39	D45	D98
V (50/60 Hz)	24	120	180-208V 50Hz / 208-240V 60Hz	480	600	277

Note: other coil voltages available upon request.

Direct Current

Code	C03	C13
V dc	24	125

Note: 1) Spare coil in direct current (DC) only for CWB40...80 A.

General Information

Circuit Protection

Disconnect Switches

Motor Protectors

Contactors

Overloads

Enclosed Starters

Relays

Pushbuttons and Pilot Lights

Terminal Blocks

Power Factor Correction

Appendix A

Appendix B

CWB Series

Technical Data Terminal Markings According to IEC/EN 60947

	Diagram	Configuration	Auxiliary contacts		Reference code
			NO	NC	
3-poles contactors with built-in auxiliary contacts					
General Information		11	1	1	CWB9-11-30◆ CWB12-11-30◆ CWB18-11-30◆ CWB25-11-30◆ CWB32-11-30◆ CWB38-11-30◆ CWB40-11-30◆ CWB50-11-30◆ CWB65-11-30◆ CWB80-11-30◆
Front mounted auxiliary contact blocks					
Motor Protectors		20	2	0	BFB-20
Contactors		11	1	1	BFB-11
Overloads		02	0	2	BFB-02
Enclosed Starters		40	4	0	BFB-40
		22	2	2	BFB-22
Relays		22	2	2	BFB-22 EL
		04	0	4	BFB-04
Pushbuttons and Pilot Lights		31	3	1	BFB-31
		13	1	3	BFB-13
Side mounted auxiliary contact blocks					
Terminal Blocks		11	1	1	BLB11
Power Factor Correction		20	2	0	BLB20
		02	2	0	BLB02
Appendix A		11	1	1	BLRB11
Appendix B		20	2	0	BLRB20
		02	2	0	BLRB02

Technical Data

Terminal Markings According to EN 50012

Diagram	Configuration	Auxiliary contacts		Reference code
		NO	NC	
Front mounting auxiliary contact blocks				
	20	2	0	BFB-20 EN
	11	1	1	BFB-11 EN
	02	0	2	BFB-02 EN
	40	4	0	BFB-40 EN
	22	2	2	BFB-22 EN
	04	0	4	BFB-04 EN
	31	3	1	BFB-31EN
	13	1	3	BFB-13 EN

General Information

Circuit Protection

Disconnect Switches

Motor Protectors

Contactors

Overloads

Enclosed Starters

Relays

Pushbuttons and Pilot Lights

Terminal Blocks

Power Factor Correction

Appendix A

Appendix B

CWB Series

General Information

Technical Data

Circuit Protection

General Data

Reference code	CWB9	CWB12	CWB18	CWB25	CWB32	CWB38	CWB40	CWB50	CWB65	CWB80
Compliance with the standards	IEC/EN 60947-1, IEC/EN 60947-4-1, IEC/EN 60947-5-1, UL 508									
Rated insulation voltage U_i (pollution degree 3)	IEC/EN 60947-4-1 (V)		690 V				1,000 V			
	UL, CSA (V)		600 V							
Rated impulse-withstand voltage U_{imp}	IEC/EN 60947-1 (kV)		6 kV							
Frequency limits			25...400 (Hz)							
Mechanical lifespan	AC coil (million cycles)		10				6			
	DC coil (million cycles)		10				6			
Electrical lifespan	I_e AC-3 (million cycles)		2.0	2.0	1.8	1.6	1.6	1.2	1.6	1.2
Degree of protection (IEC/EN 60529)	Main terminals		IP10 (front)							
	Coil and auxiliary contacts		IP20 (front)							
Mounting	By screws or DIN 35 mm rail (EN 50022)									
Coil connection points	Contactors with AC coil		2							
	Contactors with DC coil		2							
Vibration resistance (IEC/EN 60068-2-6)	Open contactor (g)		4							
	Closed contactor (g)		4							
Resistance to mechanical shocks ($\frac{1}{2}$ sine wave = 11 ms - IEC/EN 60068-2-27)	Open contactor (g)		10							
	Closed contactor (g)		15							
Ambient temperature	Operating		-25 °C...+55 °C							
	Storage		-55 °C...+80 °C							
Maximum operation altitude without modification in the rated values ¹⁾	3,000 m									

Disconnect Switches

Motor Protectors

Contactors

Overloads

Control Circuit - Alternating Current (AC)

Reference code	CWB9...38	CWB40...80			
Rated insulation voltage U_i (pollution degree 3)	IEC/EN 60947-4-1 (V)	690	1,000		
	UL, CSA (V)	600	600		
Standard voltages at 50/60 Hz	(V)	12...600	24...600		
Coil operating limits	(xUs)	0.8...1.1	0.8...1.1		
Coil 50/60 Hz	Pick up (xUs)	0.5...0.8	0.5...0.8		
	Drop out (xUs)	0.2...0.6	0.2...0.6		
Average consumption	Operating at 60 Hz	Operating at 50 Hz	Operating at 60 Hz	Operating at 50 Hz	
	Magnetic circuit closed (VA)	7.5	9	17.2	27
Coil 50/60 Hz	Power factor switching on (cos ϕ)	0.7	0.8	0.55	0.56
	Power factor switched on	0.27	0.24	0.28	0.25
	Thermal power dissipation (W)	5...7	5...7	3.7...6.3	3.7...6.3
	Closing of the magnetic circuit (VA)	75	90	185	202
Operation average time	Closing of the NO contacts (ms)	15...25		10...15	
	Opening of the NO contacts (ms)	8...12			

Enclosed Starters

Relays

Pushbuttons and Pilot Lights

Control Circuit - Direct Current (DC)

Reference code	CWB9...38	CWB40...80			
Rated insulation voltage U_i (pollution degree 3)	IEC/EN 60947-4-1 (V)	690	1,000		
	UL, CSA (V)	600	600		
Standard voltages	(V)	12...500	12...500		
Coil operating limits	(xUs)	0.8...1.1	0.8...1.1		
	Pick up (xUs)	0.5...0.8	0.5...0.8		
	Drop out (xUs)	0.1...0.4	0.1...0.4		
Average consumption	1.0 x use the coil cold		1.0 x use the coil cold		
	Magnetic circuit closed (W)	5.8	5.8	14.5	
	Closing of the magnetic circuit (W)	5.8	5.8	105	
Operation average time	Closing of the NO contacts (ms)	35...45		20...30	
	Opening of the NO contacts (ms)	8...12		4...8	
Thermal power dissipation	(W)	5...7	5...7	12...16	

Terminal Blocks

Power Factor Correction

Appendix A

Appendix B

Note: 1) For altitudes of 3,000...4,000 m ($0.90 \times I_e$ and $0.80 \times U_i$) and of 4,000...5,000 m ($0.80 \times I_e$ and $0.75 \times U_i$).

Technical Data

Main Contacts

Reference code			CWB9	CWB12	CWB18	CWB25	CWB32	CWB38	CWB40	CWB50	CWB65	CWB80	
Rated operational current I_e	AC-3 ($U_e \leq 440$ V)	(A)	9	12	18	25	32	38	40	50	65	80	
	AC-4 ($U_e \leq 440$ V)	(A)	4.4	5.8	8.5	10.4	13.7	13.7	18.5	18.5	26	32	
	AC-1 ($\theta \leq 55$ °C, $U_e \leq 690$ V)	(A)	25	25	32	40	50	50	60	90	110	110	
Rated operational voltage U_e	IEC/EN 60947-4-1	(V)	690 V					1,000 V					
	UL, CSA	(V)	600 V										
Conventional thermal current I_m ($\theta \leq 55$ °C)		(A)	25	25	32	40	50	50	60	90	110	110	
Making capacity - IEC/EN 60947		(A)	250	250	300	450	550	550	550	1,000	1,000	1,000	
Breaking capacity IEC/EN 60947	($U_e \leq 400$ V)	(A)	250	250	300	450	550	550	550	1,000	1,000	1,000	
	($U_e = 500$ V)	(A)	220	220	250	350	450	450	480	880	880	880	
	($U_e = 690$ V)	(A)	150	150	180	250	350	350	350	640	640	640	
Acceptable short-time current (no current flowing during re-recovery time of 15min and $\theta \leq 40$ °C)	1s	(A)	210	210	240	380	400	430	720	820	900	900	
	10s	(A)	105	105	145	240	260	310	320	400	520	640	
	1min	(A)	60	60	80	120	130	150	165	230	340	360	
	10min	(A)	30	30	40	50	60	60	85	110	130	130	
Short circuit protection of the main contacts	@600 V - UL/CSA	(kA)	5										
	Coordination type 1	(A)	25	40	50	63	63	63	80	100	125	160	
Fuse (gL/gG)	Coordination type 2	(A)	20	20	25	35	50	50	63	80	100	125	
Impedance per pole		(m Ω)	2.5	2.5	2.5	2	2	2	1.6	1.6	1.6	1.6	
Average power dissipation per pole	AC-1	(W)	1.5	1.5	2.5	3.2	5	5	6	13	19	19	
	AC-3	(W)	0.2	0.4	0.8	1.2	2	3	3	4	7	10	
Utilization category AC-3													
Rated operational current I_e ($\theta \leq 55$ °C)	$U_e \leq 440$ V	(A)	9	12	18	25	32	38	40	50	65	80	
	$U_e \leq 500$ V	(A)	9	12	15.8	23	28.5	28.5	35	45	55	75	
	$U_e \leq 690$ V	(A)	7	9	12.8	16.5	21	21	32	35	40	50	
Orientative rated operational power Three-phase induction motors (50/60 Hz) IV poles - 1,800 rpm	220/240 V	(kW)	2.2	3	4.5	6.5	7.5	9.2	11	15	18.5	22	
		(cv)	3	4	6	8.7	10	12.5	15	20	25	29	
	380/400 V	(kW)	4	5.5	7.5	12.5	15	18.5	18.5	22	30	37	
		(cv)	5.5	7.5	10	16.8	20	25	25	29	40	50	
	415/440 V	(kW)	4.5	6.5	9.2	12.5	15	18.5	22	30	37	45	
		(cv)	6	8.7	12.5	16.8	20	25	29	40	50	60	
	500 V	(kW)	5.5	7.5	10	15	18.5	18.5	22	30	37	55	
		(cv)	7.5	10	13.4	20	25	25	29	40	50	74	
	660/690 V	(kW)	5.5	7.5	11	15	18.5	18.5	30	33	37	45	
		(cv)	7.5	10	15	20	25	25	40	44	50	60	
	Maximum percentage	600 ops./h	(%)	100	100	100	100	100	100	100	100	100	100
	Utilization category AC-4												
Rated operational current I_e	($U_e \leq 440$ V)	(A)	4.4	5.8	8.5	10.4	13.7	13.7	18.5	18.5	26	32	
	($U_e \leq 500$ V)	(A)	3.9	5.1	7.5	12	13.9	13.9	17.5	23.5	28.5	33	
	($U_e \leq 690$ V)	(A)	2.8	3.7	5.4	12	12.8	12.8	14	18	22	26	
Orientative rated operational power Three-phase induction motors (50/60 Hz) IV poles - 1,800 rpm (200,000 operations)	220/240 V	(kW)	1.5	1.5	2.2	3	4	4	4.5	5.5	7.5	11	
		(cv)	2.0	2.0	2.9	4.0	5.4	5.4	6.0	7.4	10.1	14.7	
	380/400 V	(kW)	2.2	3.7	4	5.5	7.5	7.5	9.2	11	15	18.5	
		(cv)	2.9	5.0	5.4	7.4	10.1	10.1	12.3	14.7	20.1	24.8	
	415/440 V	(kW)	2.2	3	3.7	5.5	7.5	7.5	11	11	15	22	
		(cv)	2.9	4.0	5.0	7.4	10.1	10.1	14.7	14.7	20.1	29.5	
	500 V	(kW)	2.2	3	5	7.5	9	9	11	15	18.5	22	
		(cv)	2.9	4.0	6.7	10.1	12.1	12.1	14.7	20.1	24.8	29.5	
	660/690 V	(kW)	2.2	3	5	10	11	11	12.5	15	20	25	
		(cv)	2.9	4.0	6.7	13.4	14.7	14.7	16.8	20.1	26.8	33.5	

CWB Series

Technical Data

General Information

Circuit Protection

Disconnect Switches

Motor Protectors

Contactors

Overloads

Enclosed Starters

Relays

Pushbuttons and Pilot Lights

Terminal Blocks

Power Factor Correction

Appendix A

Appendix B

Main Contacts

Reference code			CWB9	CWB12	CWB18	CWB25	CWB32	CWB38	CWB40	CWB50	CWB65	CWB80
Utilization category AC-1												
3P (NO)												
Conventional thermal current I _{th} (θ ≤ 55 °C)	(A)		25	25	32	40	50	50	60	90	110	110
Maximum orientative operational current according to the ambient temperature	θ ≤ 60 °C (U _e ≤ 690 V)	(A)	25	25	32	40	50	50	60	90	110	110
Max. operational power θ ≤ 55 °C (three-phase resistors)	220/230 V	(kW)	9.5	9.5	12	15	19	19	22.5	34	42	42
	380/400 V	(kW)	16.5	16.5	21	26	33	33	39.5	59	72.5	72.5
	415/440 V	(kW)	19	19	24.5	30.5	38	38	45.5	68.5	84	84
	500 V	(kW)	21.5	21.5	27.5	34.5	43	43	52	77	95	95
	660/690 V	(kW)	28.5	28.5	36.5	45.5	57	57	66	100	125	125
Current values for connection	2 poles in parallel		I _e x 1.7									
	3 poles in parallel		I _e x 2.4									
	4 poles in parallel		-									
Percentage of maximum operational current	600 ops./h	(%)	100	100	100	100	100	100	100	100	100	100

Auxiliary Contacts

Reference code			CWB9...38 (built-in)	BFB (front mounted)	BLB (side mounted)
Compliance with the standards			IEC/EN 60947-5-1		
Rated insulation voltage U _i (pollution degree 3)	IEC/EN 60947-4-1, VDE 0660	(V)	690		
	UL, CSA	(V)	600		
Rated operational voltage U _e	IEC/EN 60947-4-1, VDE 0660	(V)	690		
	UL, CSA	(V)	600		
Conventional thermal current I _{th} (θ ≤ 55 °C)		(A)	10		
Rated operational current I _e					
AC-15 (IEC/EN 60947-5-1)	220/230 V	(A)	10		
	380/440 V	(A)	4		
	500 V	(A)	2.5		
	660/690 V	(A)	1.5		
DC-13 (IEC/EN 60947-5-1)	24 V	(A)	4		
	48 V	(A)	2		
	110 V	(A)	0.7		
	220 V	(A)	0.3		
	440 V	(A)	0.15		
Making capacity	U _e ≤ 690 V 50/60 Hz - AC-15	(A)	10 x I _e		
Breaking capacity	U _e ≤ 400 V 50/60 Hz - AC-15	(A)	1 x I _e		
Short circuit protection with fuse	(gL/gG)	(A)	10		
Control circuit reliability	(V / mA)		17 / 5		
Electrical lifespan	(million cycles)		1		
Mechanical lifespan	(million cycles)		10		
Non-overlapping time between NO and NC contacts		(ms)	1.5		
Impedance of the contacts		(mΩ)	2.5		

Technical Data

Terminal Capacity and Tightening Torque

			Conductor cross-section		
			Power circuit		
Model			CWB9...18	CWB25...38	CWB40...80
Mounting system screw type			Phillips number 2	Phillips number 2	ALLEN 4 mm
Flexible conductor without terminal	AWG		1 x 16-10 2 x 16-10	1 x 16-10 2 x 16-10	1 x 14-3 2 x 14-3
Flexible conductor with terminal	AWG		1 x 16-10 2 x 16-12	1 x 16-8 2 x 16-10	1 x 14-3 2 x 14-3
Solid wire	AWG		1 x 16-10 2 x 16-10	1 x 14-18 2 x 14-18	1 x 14-3 2 x 14-3
Tightening torque	(Nm)		1.7	2.5	5.0
Control and auxiliary circuit					
Models			CWB9...38	CWB40...80	
Mounting system screw type			Phillips number 2	Phillips number 2	
Flexible conductor without terminal	AWG		1 x 16-12 2 x 16-12	1 x 16-12 2 x 16-12	
Flexible conductor with terminal	AWG		1 x 16-12 2 x 16-14	1 x 16-12 2 x 16-14	
Solid wire	AWG		1 x 16-12 2 x 16-12	1 x 16-12 2 x 16-12	
Tightening torque	(Nm)		1.0	1.0	
Auxiliary contact blocks					
Models			BFB (front)	BLB (side)	
Mounting system screw type			Phillips number 2		
Conductor cross-section					
Flexible conductor without terminal	AWG		1 x 16-14 2 x 16-14		
Flexible conductor with terminal	AWG		1 x 16-14 2 x 16-14		
Solid wire	AWG		1 x 16-14 2 x 16-14		
Tightening torque	(Nm)		1.0		

General Information

Circuit Protection

Disconnect Switches

Motor Protectors

Contactors

Overloads

Enclosed Starters

Relays

Pushbuttons and Pilot Lights

Terminal Blocks

Power Factor Correction

Appendix A

Appendix B

CWBN Technical Data

Reference code			CWBN00	CWBN0	CWBN1	CWBN2
Compliance with the standards			IEC/EN 60947-1, IEC/EN 60947-4-1, IEC/EN 60947-5-1, UL 508			
Rated insulation voltage U_i (pollution degree 3)	IEC/EN 60947-4-1	(V)	690 V			1,000 V
	UL, CSA	(V)	600 V			
Rated impulse-withstand voltage U_{imp}	IEC/EN 60947-1	(kV)	6 kV			
Frequency limits		(Hz)	25...400			
Mechanical lifespan	AC coil	(million cycles)	10			6
	DC coil	(million cycles)	10			6
Electrical lifespan	1e AC-3	(million cycles)	2.0	1.8	1.6	1.6
Degree of protection (IEC/EN 60529)	Main terminals		IP10 (front)			
	Coil and auxiliary contacts		IP20 (front)			
Mounting	By screws or DIN 35 mm rail (EN 50022)					
Coil connection points	Contactors with AC coil		2			
	Contactors with DC coil		2			
Vibration resistance (IEC/EN 60068-2-6)	Open contactor	(g)	4			
	Closed contactor	(g)	4			
Resistance to mechanical shocks (½ sine wave = 11ms - IEC/EN 60068-2-27)	Open contactor	(g)	10			
	Closed contactor	(g)	15			
Ambient temperature	Operating		-25 °C...+55 °C			
	Storage		-55 °C...+80 °C			
Maximum operation altitude without modification in the rated values1)			3,000 m			

Control Circuit - Alternating Current (AC)

Reference code			CWBN00...1	CWBN2		
Rated insulation voltage U_i (pollution degree 3)	IEC/EN 60947-4-1	(V)	690	1,000		
	UL, CSA	(V)	600	600		
Standard voltages at 50/60 Hz		(V)	12...600	24...600		
Coil operating limits		(xUs)	0.8...1.1	0.8...1.1		
Coil 50/60 Hz	Pick up	(xUs)	0.5...0.8	0.5...0.8		
	Drop out	(xUs)	0.2...0.6	0.2...0.6		
Average consumption			Operating at 60 Hz	Operating at 50 Hz	Operating at 60 Hz	Operating at 50 Hz
Coil 50/60 Hz	Magnetic circuit closed	(VA)	7.5	9	17.2	27
	Power factor switching on	(cos ϕ)	0.7	0.8	0.55	0.56
	Power factor switched on		0.27	0.24	0.28	0.25
	Thermal power dissipation	(W)	5...7	5...7	3.7...6.3	3.7...6.3
	Closing of the magnetic circuit	(VA)	75	90	185	202
Operation average time	Closing of the NO contacts	(ms)	15...25		10...15	
	Opening of the NO contacts	(ms)	8...12			

Control Circuit - Direct Current (DC)

Reference code			CWBN00...1	CWBN2
Rated insulation voltage U_i (pollution degree 3)	IEC/EN 60947-4-1	(V)	690	1,000
	UL, CSA	(V)	600	600
Standard voltages		(V)	12...500	12...500
Coil operating limits		(xUs)	0.8...1.1	0.8...1.1
	Pick up	(xUs)	0.5...0.8	0.5...0.8
	Drop out	(xUs)	0.1...0.4	0.1...0.4
Average consumption			1.0 x use the coil cold	1.0 x use the coil cold
Operation average time	Magnetic circuit closed	(W)	5.8	14.5
	Closing of the magnetic circuit	(W)	5.8	105
	Closing of the NO contacts	(ms)	35...45	20...30
	Opening of the NO contacts	(ms)	8...12	4...8
Thermal power dissipation		(W)	5...7	12...16

Note: 1) For altitudes of 3,000...4,000 m (0.90 x I_e and 0.80 x U_i) and of 4,000...5,000 m (0.80 x I_e and 0.75 x U_i).

Technical Data Main Contacts

Reference code			CWBN00	CWBN0	CWBN1	CWBN2	
Rated operational current Ie	AC-3 (Ue ≤440 V)	(A)	9	18	25	50	
	AC-4 (Ue ≤440 V)	(A)	4.4	8.5	10.4	18.5	
	AC-1 (0 ≤55 °C, Ue ≤690 V)	(A)	25	32	40	90	
Rated operational voltage Ue	IEC/EN 60947-4-1	(V)	690 V			1,000 V	
	UL, CSA	(V)	600 V				
Conventional thermal current Ith (0≤55 °C)		(A)	25	32	40	90	
Making capacity - IEC/EN 60947		(A)	250	300	450	1,000	
Breaking capacity IEC/EN 60947	(Ue ≤400 V)	(A)	250	300	450	1,000	
	(Ue = 500 V)	(A)	220	250	350	880	
	(Ue = 690 V)	(A)	150	180	250	640	
Acceptable short-time current (no current flowing during recovery time of 15min and 0 ≤40 °C)	1s	(A)	210	240	380	820	
	10s	(A)	105	145	240	400	
	1min	(A)	60	80	120	230	
	10min	(A)	30	40	50	110	
Short circuit protection of the main contacts Fuse (gL/gG)	@600 V - UL/CSA	(kA)	5				
	Coordination type 1	(A)	25	50	63	100	
	Coordination type 2	(A)	20	25	35	80	
Impedance per pole		(m)	2.5	2.5	2	1.6	
Average power dissipation per pole	AC-1	(W)	1.5	2.5	3.2	13	
	AC-3	(W)	0.2	0.8	1.2	4	
Utilization category AC-3							
Rated operational current Ie (0 ≤55 °C)	Ue ≤440 V	(A)	9	18	25	50	
	Ue ≤500 V	(A)	9	15.8	23	45	
	Ue ≤690 V	(A)	7	12.8	16.5	35	
Orientative rated operational power Three-phase induction motors (50/60 Hz) IV poles - 1,800 rpm	220/240 V	(kW)	2.2	4.5	6.5	15	
		(cv)	3	6	8.7	20	
	380/400 V	(kW)	4	7.5	12.5	22	
		(cv)	5.5	10	16.8	29	
	415/440 V	(kW)	4.5	9.2	12.5	30	
		(cv)	6	12.5	16.8	40	
	500 V	(kW)	5.5	10	15	30	
		(cv)	7.5	13.4	20	40	
	660/690 V	(kW)	5.5	11	15	33	
		(cv)	7.5	15	20	44	
	Maximum percentage	600 ops./h	(%)	100	100	100	100
	Utilization category AC-4						
Rated operational current Ie	(Ue ≤440 V)	(A)	4.4	8.5	10.4	18.5	
	(Ue ≤500 V)	(A)	3.9	7.5	12	23.5	
	(Ue ≤690 V)	(A)	2.8	5.4	12	18	
Orientative rated operational power Three-phase induction motors (50/60 Hz) IV poles - 1,800 rpm (200,000 operations)	220/240 V	(kW)	1.5	2.2	3	5.5	
		(cv)	2.0	2.9	4.0	7.4	
	380/400 V	(kW)	2.2	4	5.5	11	
		(cv)	2.9	5.4	7.4	14.7	
	415/440 V	(kW)	2.2	3.7	5.5	11	
		(cv)	2.9	5.0	7.4	14.7	
	500 V	(kW)	2.2	5	7.5	15	
		(cv)	2.9	6.7	10.1	20.1	
	660/690 V	(kW)	2.2	5	10	15	
		(cv)	2.9	6.7	13.4	20.1	

CWBN

Technical Data

Main Contacts

Reference code			CWBN00	CWBN0	CWBN1	CWBN2
Utilization category AC-1						
3P (NO)						
Conventional thermal current I _{th} (0 ≤ 55 °C)	(A)		25	32	40	90
Maximum orientative operational current according to the ambient temperature 0 ≤ 60 °C (U _e ≤ 690 V)	(A)		25	32	40	90
Max. operational power 0 ≤ 55 °C (three-phase resistors)	220/230 V	(kW)	9.5	12	15	34
	380/400 V	(kW)	16.5	21	26	59
	415/440 V	(kW)	19	24.5	30.5	68.5
	500 V	(kW)	21.5	27.5	34.5	77
Current values for connection	2 poles in parallel		I _e x 1.7			
	3 poles in parallel		I _e x 2.4			
	4 poles in parallel		-			
Percentage of maximum current	600 ops./h operational	(%)	100	100	100	100

Auxiliary Contacts

Reference code			CWBN00 (built-in)	BFB (front mounted)	BLB (side mounted)
Compliance with the standards			IEC/EN 60947-5-1		
Rated insulation voltage U _i (pollution degree 3)	IEC/EN 60947-4-1, VDE 0660	(V)	690		
	UL, CSA	(V)	600		
Rated operational voltage U _e	IEC/EN 60947-4-1, VDE 0660	(V)	690		
	UL, CSA	(V)	600		
Conventional thermal current I _{th} (0 ≤ 55 °C)		(A)	10		

Rated operational current I_e

AC-15 (IEC/EN 60947-5-1)	220/230 V	(A)	10		
	380/440 V	(A)	4		
	500 V	(A)	2.5		
	660/690 V	(A)	1.5		
DC-13 (IEC/EN 60947-5-1)	24 V	(A)	4		
	48 V	(A)	2		
	110 V	(A)	0.7		
	220 V	(A)	0.3		
	440 V	(A)	0.15		
Making capacity	U _e ≤ 690 V 50/60 Hz - AC-15	(A)	10 x I _e		
Breaking capacity	U _e ≤ 400 V 50/60 Hz - AC-15	(A)	1 x I _e		
Short circuit protection with fuse (gL/gG)		(A)	10		
Control circuit reliability (V / mA)			17 / 5		
Electrical lifespan (million cycles)			1		
Mechanical lifespan (million cycles)			10		
Non-overlapping time between NO and NC contacts		(ms)	1.5		
Impedance of the contacts		(mΩ)	2.5		

General Information

Circuit Protection

Disconnect Switches

Motor Protectors

Contactors

Overloads

Enclosed Starters

Relays

Pushbuttons and Pilot Lights

Terminal Blocks

Power Factor Correction

Appendix A

Appendix B

Technical Data

Terminal Capacity and Tightening Torque

		Conductor cross-section		
Power circuit				
Model		CWBN00/CWBNO	CWBN1	CWBN2
Mounting system screw type		Phillips number 2	Phillips number 2	ALLEN 4 mm
Flexible conductor without terminal		1 x 1...6 mm ² / 16...10 AWG 2 x 1...6 mm ² / 16...10 AWG	1 x 2.5...10 mm ² / 14...8 AWG 2 x 2.5...10 mm ² / 14...8 AWG	1 x 2.5...35 mm ² / 14...2 AWG 2 x 2.5...35 mm ² / 14...2 AWG
Flexible conductor with terminal		1 x 1...6 mm ² / 16...10 AWG 2 x 1...4 mm ² / 16...12 AWG	1 x 1.5...10 mm ² / 16...8 AWG 2 x 1.5...6 mm ² / 16...10 AWG	1 x 2.5...35 mm ² / 14...2 AWG 2 x 2.5...35 mm ² / 14...2 AWG
Solid wire		1 x 1...6 mm ² / 16...10 AWG 2 x 1...6 mm ² / 16...10 AWG	1 x 2.5...10 mm ² / 14...8 AWG 2 x 2.5...10 mm ² / 14...8 AWG	1 x 2.5...35 mm ² / 14...2 AWG 2 x 2.5...35 mm ² / 14...2 AWG
Tightening torque		1.7 Nm / 15 lb.in	2.5 Nm / 22 lb.in	5.0 Nm / 60 lb.in

Control and auxiliary circuit

Models		CWBN00..1	CWBN2
Mounting system screw type		Phillips number 2	Phillips number 2
Flexible conductor without terminal		1 x 1...4 mm ² / 16...12 AWG 2 x 1...4 mm ² / 16...12 AWG	1 x 1...4 mm ² / 16...12 AWG 2 x 1...4 mm ² / 16...12 AWG
Flexible conductor with terminal		1 x 1...4 mm ² / 16...12 AWG 2 x 1...2.5 mm ² / 16...14 AWG	1 x 1...4 mm ² / 16...12 AWG 2 x 1...2.5 mm ² / 16...14 AWG
Solid wire		1 x 1...4 mm ² / 16...12 AWG 2 x 1...4 mm ² / 16...12 AWG	1 x 1...4 mm ² / 16...12 AWG 2 x 1...4 mm ² / 16...12 AWG
Tightening torque		1.0 Nm / 8.8 lb.in	1.0 Nm / 8.8 lb.in

Auxiliary contact blocks

Models		BFB (front)	BLB (side)
Mounting system screw type		Phillips number 2	
Conductor cross-section			
Flexible conductor without terminal		1 x 1...2.5 mm ² / 16...14 AWG 2 x 1...2.5 mm ² / 16...14 AWG	1 x 1...2.5 mm ² / 16...14 AWG 2 x 1...2.5 mm ² / 16...14 AWG
Flexible conductor with terminal		1 x 1...2.5 mm ² / 16...14 AWG 2 x 1...2.5 mm ² / 16...14 AWG	1 x 1...2.5 mm ² / 16...14 AWG 2 x 1...2.5 mm ² / 16...14 AWG
Solid wire		1 x 1...2.5 mm ² / 16...14 AWG 2 x 1...2.5 mm ² / 16...14 AWG	1 x 1...2.5 mm ² / 16...14 AWG 2 x 1...2.5 mm ² / 1...1.5/16 AWG
Tightening torque		1.0 Nm / 8.8 lb.in	

- General Information
- Circuit Protection
- Disconnect Switches
- Motor Protectors
- Contactors
- Overloads
- Enclosed Starters
- Relays
- Pushbuttons and Pilot Lights
- Terminal Blocks
- Power Factor Correction
- Appendix A
- Appendix B

Contactors

General Information

CWB Series

Dimensions (mm)

CWB9...18, CWB25...38, CWBN00...1

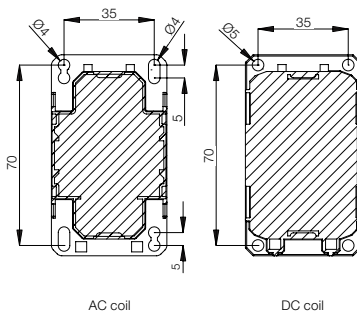
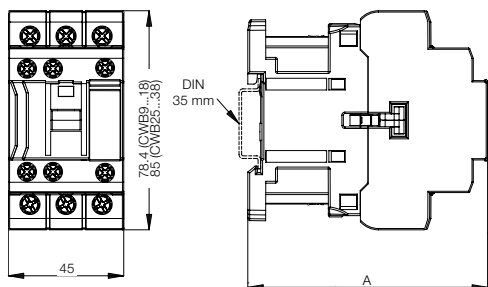

Models	A	
	AC coil	DC coil
CWB9...18 CWBNO0...0	89.5	98.5
CWB25...38 CWBNI	93	102.2

Circuit Protection

Disconnect Switches

Motor Protectors

CWB40...80, CWBN2

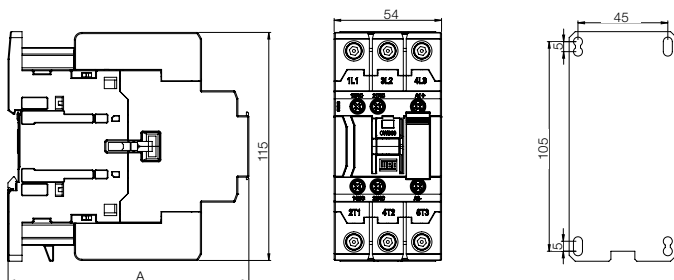

Models	A	
	AC coil	DC coil
CWB40...80 CWBNI	120.6	120.6

Mounting Position

CWB9...80

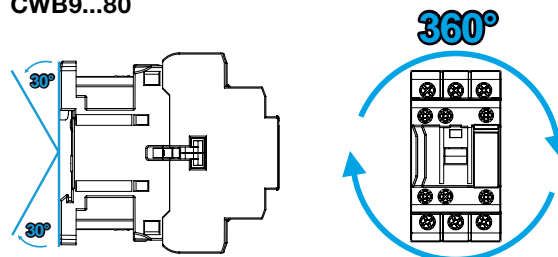

Contactors

Overloads

Enclosed Starters

CWB9...18, CWB25...38, CWB40...80 + FBF
(Front Mounted Auxiliary Contact Block)

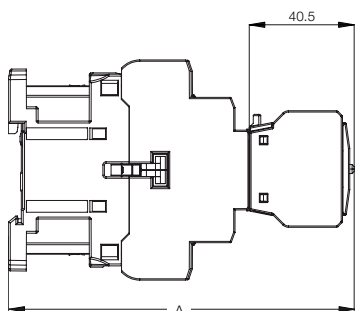

Models	A	
	AC coil	DC coil
CWB9...18	130	136.2
CWB25...38	133.4	142.6
CWB40...80	161.1	161.1

CWB9...18, CWB25...38 + BLB
(Side Mounted Auxiliary Contact Block)

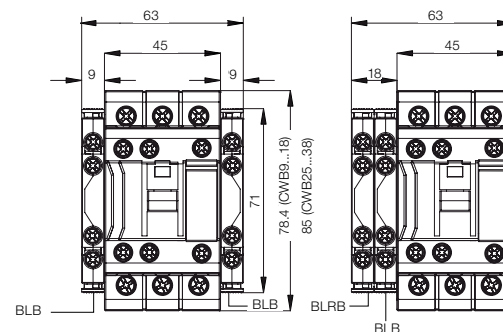

Relays

Pushbuttons and Pilot Lights

Terminal Blocks

2 x CWB9...38 + IM1 (Mechanical Interlock)
2 x CWB40...80 + IM2 (Mechanical Interlock)

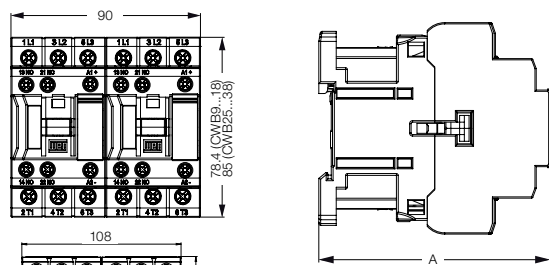

Models	A	
	AC coil	DC coil
CWB9...18	89.5	98.5
CWB25...38	93	102.2
CWB40...80	120.6	120.6

CWB40...80 + BLB
(Side-Mounted Contact Block)

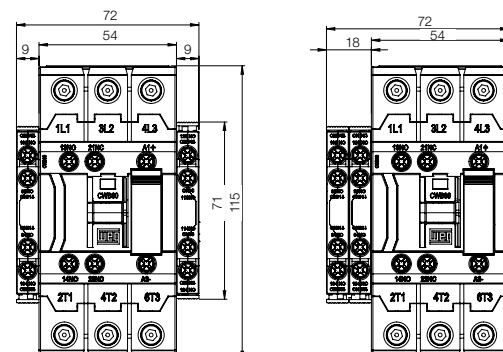

Power Factor Correction

Appendix A
Appendix B

Dimensions (mm)

CWB9...38 + Easy Connection Busbars

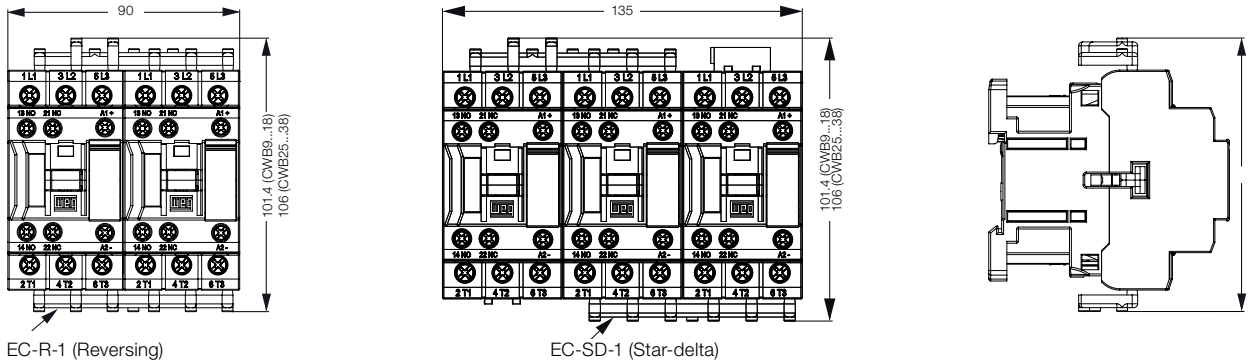

CWB40...80 + Easy Connection Busbars

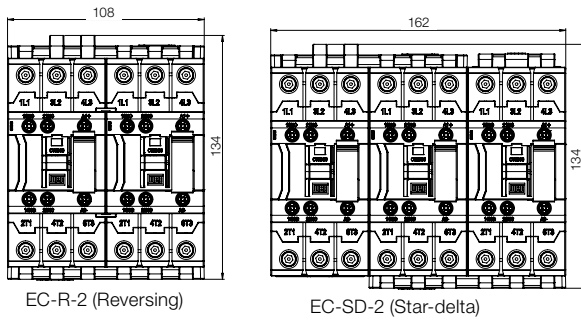

CWB9...38 + RW27-2D (Overload Relay)

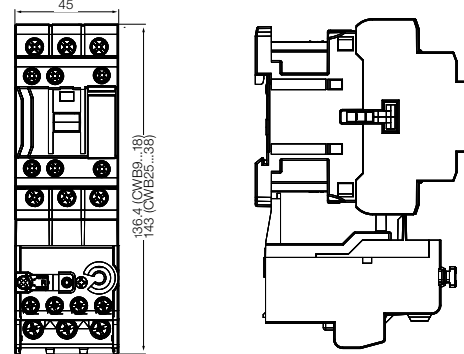

CWB9...38 + MPW16/18 (Manual Motor Protector)

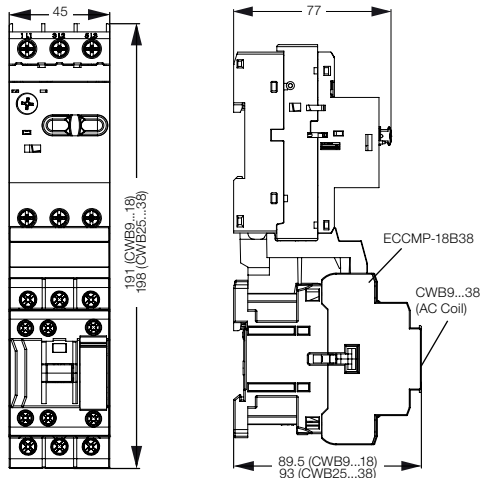

CWB9...38 + MPW25/40 (Manual Motor Protector)

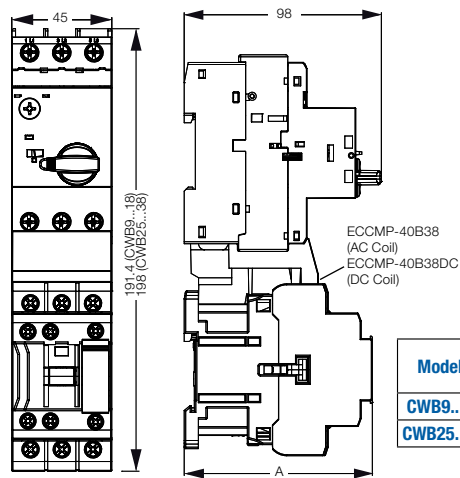

Models	A	
	AC coil	DC coil
CWB9...18	89.5	98.5
CWB25...38	93	102.2

CWB40 + RW67-5D (Overload Relay)

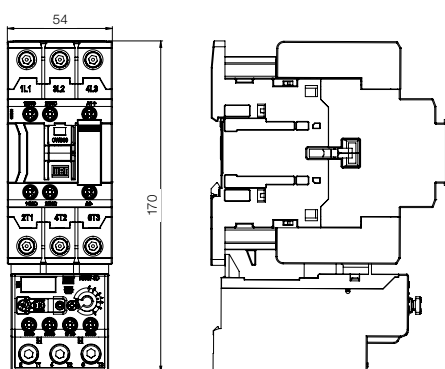

CWB40...80 + MPW80 (Manual Motor Protector)

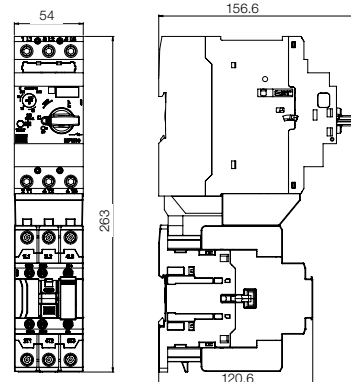

CWBS Safety Contactors

CWBS line of contactors for safety applications (from 9 A to 80 A in AC-3) was developed in compliance with IEC and UL standards, featuring mechanically linked contacts (IEC/EN 60947-5-1) and mirror contacts (IEC/EN 60947-4-1), which provide proper operation of safety circuits of machines and equipment that must operate in compliance with international safety standards.



Standard Features:

- Mechanically linked Contact and Mirror Contacts
- Easy Access Power and Control Terminals
- Protection against inadvertent operation
- High Visibility Color (Safety Yellow)
- Surface or Din Rail Mount

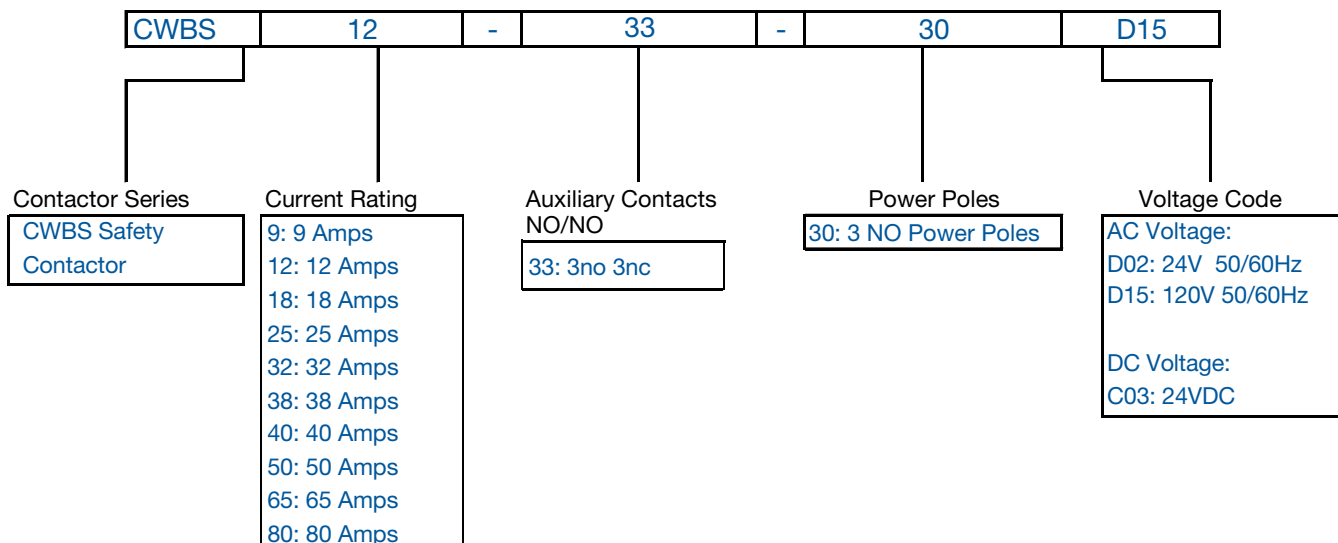

CWBS Contactor Catalog Number Sequence



Power Contactors for Safety Applications Three-Pole from 9 A to 80 A (AC-3)

Selection Table

Three-Pole CWBS Contactors from 9 A to 80 A (AC-3)

Ie máx. (Ue ≤440 V)	Maximum UL Horsepower						Built-in auxiliary contacts per contactor		Catalog Number	List Price AC Coil	List Price DC Coil	Multiplier
	Single Phase		Three Phase				 *3 NO	 *1 NC				
	115V	230V	200V	230V	480V	575V						
9	3/4	1.5	3	3	5	7 1/2	3	3	CWBS9-33-30*	\$205	\$232	Z1
12	3/4	2	3	3	7 1/2	10	3	3	CWBS12-33-30*	\$227	\$259	
18	1	3	5	5	10	15	3	3	CWBS18-33-30*	\$259	\$296	
25	2	5	7 1/2	7 1/2	15	15	3	3	CWBS25-33-30*	\$290	\$329	
32	3	5	10	10	20	25	3	3	CWBS32-33-30*	\$338	\$387	
38	3	7.5	10	10	25	25	3	3	CWBS38-33-30*	\$378	\$434	
40	3	7 1/2	10	15	30	30	3	3	CWBS40-33-30*	\$425	\$506	
50	3	10	15	15	40	40	3	3	CWBS50-33-30*	\$478	\$550	
65	5	10	20	20	50	50	3	3	CWBS65-33-30*	\$577	\$641	
80	7 1/2	15	20	25	50	60	3	3	CWBS80-33-30*	\$652	\$713	

Replace “*” by the appropriate coil voltage code.

Alternating Current

Code	D02	D15
V (50/60 Hz)	24	120

Direct Current

Code	C03
V dc	24

Notes:

1) Other voltages on request

General Information

Circuit Protection

Disconnect Switches

Motor Protectors

Contactors

Overloads

Enclosed Starters

Relays

Pushbuttons and Pilot Lights

Terminal Blocks

Power Factor Correction

Appendix A

Appendix B

CWBS

Technical Data

Use of Contactors in Direct Current Circuits¹⁾

Utilization Category DC-5 (L/R <15ms)

Models		CWBS9	CWBS12	CWBS18	CWBS25	CWBS32	CWBS38	CWBS40	CWBS50	CWBS65	CWBS80
U _e	Poles in series	Rated operational current I _e (A)									
≤24 V	1	12	12	12	18	25	32	36	45	55	55
	2	18	18	18	25	40	40	36	45	55	55
	3	18	18	18	25	40	40	36	45	55	55
≤48 V	1	9	9	9	12	18	20	36	45	55	55
	2	18	18	18	25	40	40	36	45	55	55
	3	18	18	18	25	40	40	36	45	55	55
≤60 V	1	7.5	7.5	7.5	10	15	15	36	45	55	55
	2	18	18	18	25	40	40	36	45	55	55
	3	18	18	18	25	40	40	36	45	55	55
≤125 V	1	0.8	0.8	0.8	0.8	1.2	1.2	5	5	5	5
	2	5	5	5	5	5	5	36	45	50	50
	3	15	15	15	20	25	32	36	54	55	55
≤220 V	1	-	-	-	-	-	-	1	1	1	1
	2	0.8	0.8	0.8	0.8	0.8	0.8	5	5	5	5
	3	3	3	3	3	3	3	36	45	50	50
≤440 V	1	-	-	-	-	-	-	-	-	-	-
	2	-	-	-	-	-	-	1	1	1	1
	3	0.4	0.5	0.5	0.5	0.7	0.7	5	5	5	5
≤600 V	1	-	-	-	-	-	-	-	-	-	-
	2	-	-	-	-	-	-	-	-	-	-
	3	-	-	-	-	-	-	-	-	-	-

Wiring Diagrams

1 Pole in Series



3 Poles in Series

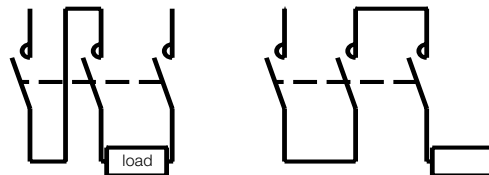

2 Poles in Series

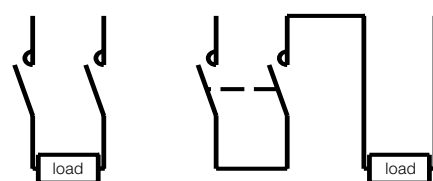

Notes: 1) Service duty according to IEC/EN 60947-4-1:

DC-1 (non-inductive or slightly inductive loads, resistive furnaces);

DC-3 (shunt-motors: starting, plugging and inching. Dynamic braking of DC motors);

DC-5 (series-motors: starting, plugging and inching. Dynamic braking of DC motors).

Contact Numbering According to IEC/EN 60947

Diagram	Configuration	Auxiliary contacts		Reference
		NO	NC	
Three-pole power contactors with built-in auxiliary contact				CWBS9...80 A
	33	3	3	CWBSxx.33.30

Basic Data

Models	CAWBS CWBS9 CWBS12 CWBS18 CWBS25 CWBS32 CWBS38 CWBS40 CWBS50 CWBS65 CWBS80												
Compliance with the standards	IEC/EN 60947-1, IEC/EN 60947-4-1, IEC/EN 60947-5-1, UL 508												
Rated insulation voltage U_i (pollution degree 3)	IEC/EN 60947-4-1 (V)	690 V						1,000 V					
	UL, CSA (V)	600 V											
Rated impulse withstand voltage U_{imp}	IEC/EN 60947-1 (kV)	6 kV											
Frequency limits	(Hz)	25...400											
Mechanical life	AC coil (millions of operations)	10						6					
	DC coil (millions of operations)	10											
Electrical life	I_e AC-3 (millions of operations)	-	2.0	2.0	1.8	1.6	1.6	1.2	1.6	1.6	1.6	1.2	
Degree of protection (IEC 60529)	Main terminals	IP10 (front)											
	Coil and auxiliary contacts	IP20 (front)											
Mounting		Screws or DIN rail 35 mm (EN 50022)											
Coil connection points	Contactors with AC coil	2											
	Contactors with DC coil	2											
Resistance to vibrations (IEC 60068-2-6)	Open contactor (g)	4											
	Closed contactor (g)	4											
Resistance to mechanical shocks (½ sine wave = 11ms - IEC 60068-2-27)	Open contactor (g)	10											
	Closed contactor (g)	15											
Ambient temperature	Operation	-25 °C...+55 °C											
	Storage	-55 °C...+80 °C											
Maximum operation altitude without modification in the rated values ¹⁾		3,000 m											

Control Circuit - Alternating Current (AC)

Models	CWBS9...38, CAWBS		CWBS40...80	
Rated insulation voltage U_i (pollution degree 3)	IEC/EN 60947-4-1 (V)	690	1,000	
	UL, CSA (V)	600	600	
Standard voltages at 50/60 Hz	(V)	12...600	24...600	
Coil operation limits	(xUs)	0.8...1.1	0.8...1.1	
Coil 50/60 Hz	Pick up (xUs)	0.5...0.8	0.5...0.8	
	Drop out (xUs)	0.2...0.6	0.2...0.6	
Average coil consumption 50/60 Hz	Closed magnetic circuit (VA)	7.5	17.5	
	Power factor switched on (cos φ)	0.27	0.28	
	Thermal power dissipation (W)	1.5...2.5	4...5.5	
	Closing of the magnetic circuit (VA)	75	185	
	Power factor switching on (cos φ)	0.7	0.55	
Average commute time	Closing of the NO contacts (ms)	15...25	10...15	
	Opening of the NO contacts (ms)	8...12	8...12	

Control Circuit - Direct Current (DC)

Models	CWBS9...38		CWBS40...80	
Rated insulation voltage U_i (pollution degree 3)	IEC/EN 60947-4-1 (V)	690	1,000	
	UL, CSA (V)	600	600	
Standard voltages	(V)	12...500	12...500	
Coil operation limits	(xUs)	0.8...1.1	0.8...1.1	
Average DC coil consumption	Pick up (xUs)	0.5...0.8	0.5...0.8	
	Drop out (xUs)	0.1...0.4	0.1...0.4	
Average DC coil consumption	Closed magnetic circuit (W)	5.8	10.6	
	Closing of the magnetic circuit (W)	5.8	105.5	
Average commute time	Closing of the NO contacts (ms)	35...45	20...30	
	Opening of the NO contacts (ms)	8...12	4...8	

Note: 1) For altitudes of 3,000...4,000 m ($0.90xI_e$ and $0.80xU_i$) and of 4,000...5,000 m ($0.80xI_e$ and $0.75xU_i$).

Technical Data

Main Contacts

Models		CWBS9	CWBS12	CWBS18	CWBS25	CWBS32	CWBS38	CWBS40	CWBS50	CWBS65	CWBS80		
Rated operational current I_e	AC-3 ($U_e \leq 440$ V)	(A)	9	12	18	25	32	38	40	50	65	80	
	AC-4 ($U_e \leq 440$ V)	(A)	4.4	5.8	8.5	10.4	13.7	13.7	18.5	18.5	26	32	
Rated operational voltage U_e	AC-1 ($\theta \leq 55$ °C, $U_e \leq 690$ V)	(A)	25	25	32	40	50	50	60	90	110	110	
	IEC/EN 60947-4-1	(V)	690						1,000 V				
	UL, CSA	(V)	600										
Conventional thermal current I_{th}	($\theta \leq 55$ °C)	(A)	25	25	32	40	50	50	60	90	110	110	
Making capacity - IEC/EN 60947		(A)	250	250	300	450	550	550	550	1,000	1,000	1,000	
Breaking capacity IEC 60947	($U_e \leq 400$ V)	(A)	250	250	300	450	550	550	550	1,000	1,000	1,000	
	($U_e = 500$ V)	(A)	220	220	250	350	450	450	480	880	880	880	
	($U_e = 690$ V)	(A)	150	150	180	250	350	350	350	640	640	640	
Acceptable short-time current (no current flowing during recovery time of 15min and $\theta \leq 40$ °C)	1s	(A)	210	210	240	380	400	430	720	820	900	900	
	10s	(A)	105	105	145	240	260	310	320	400	520	640	
	1min	(A)	61	61	84	120	138	150	165	230	340	360	
	10min	(A)	30	30	40	50	60	60	85	110	130	130	
Short circuit protection of the main contacts	@600 V - UL/CSA	(kA)	5										
	Coordination type 1	(A)	25	40	50	63	63	63	80	100	125	160	
Fuse (gL/gG)	Coordination type 2	(A)	20	25	35	40	63	63	63	80	100	125	
Average impedance per pole		(m Ω)	2.5	2.5	2.5	2	2	2	1.6	1.6	1.6	1.6	
Average power dissipation per pole	AC-1	(W)	1.5	1.5	2.5	3.2	5	5	6	13	19	19	
	AC-3	(W)	0.2	0.4	0.8	1.2	2	3	3	4	7	10	
Reliability ¹⁾	(V/mA)		50/100										
Utilization category AC-3													
Rated operational current I_e	$U_e \leq 440$ V	(A)	9	12	18	25	32	38	40	50	65	80	
	$U_e \leq 500$ V	(A)	9	12	15.8	23	28.5	28.5	35	45	55	75	
	$U_e \leq 690$ V	(A)	7	9	12.8	16.5	21	21	32	35	40	50	
Orientative rated operational power Three-phase induction motors (50/60 Hz) IV poles - 1,800 rpm	220/230 V	(kW)	2.2	3	4.5	6.5	7.5	9.2	11	15	18.5	22	
		(cv)	3	4	6	8.7	10	12.5	15	20	25	29	
	380/400 V	(kW)	4	5.5	7.5	12.5	15	18.5	18.5	22	30	37	
		(cv)	5.5	7.5	10	16.8	20	25	25	29	40	50	
	415/440 V	(kW)	4.5	6.5	9.2	12.5	15	18.5	22	30	37	45	
		(cv)	6	8.7	12.5	16.8	20	25	29	40	50	60	
500 V	(kW)	5.5	7.5	10	15	18.5	18.5	22	30	37	55		
	(cv)	7.5	10	13.4	20	25	25	29	40	50	74		
660/690 V	(kW)	5.5	7.5	11	15	18.5	18.5	30	33	37	45		
	(cv)	7.5	10	15	20	25	25	40	44	50	60		
Maximum percentage	600 ops./h	(%)	100	100	100	100	100	100	100	100	100	100	
Utilization category AC-4													
Rated operational current I_e	($U_e \leq 440$ V)	(A)	4.4	5.8	8.5	10.4	13.7	13.7	18.5	18.5	26	32	
	($U_e \leq 500$ V)	(A)	3.9	5.1	7.5	12	13.9	13.9	17.5	23.5	28.5	33	
	($U_e \leq 690$ V)	(A)	2.8	3.7	5.4	12	12.8	12.8	14	18	22	26	
Orientative rated operational power Three-phase induction motors (50/60 Hz) IV poles - 1,800 rpm (200,000 operations)	220/240 V	(kW)	1.5	1.5	2.2	3	4	4	4.5	5.5	7.5	11	
		(cv)	2.0	2.0	2.9	4.0	5.4	5.4	6.0	7.4	10.1	14.7	
	380/400 V	(kW)	2.2	3.7	4	5.5	7.5	7.5	9.2	11	15	18.5	
		(cv)	2.9	5.0	5.4	7.4	10.1	10.1	12.3	14.7	20.1	24.8	
	415/440 V	(kW)	2.2	3	3.7	5.5	7.5	7.5	11	11	15	22	
		(cv)	2.9	4.0	5.0	7.4	10.1	10.1	14.7	14.7	20.1	29.5	
500 V	(kW)	2.2	3	5	7.5	9	9	11	15	18.5	22		
	(cv)	2.9	4.0	6.7	10.1	12.1	12.1	14.7	20.1	24.8	29.5		
660/690 V	(kW)	2.2	3	5	10	11	11	12.5	15	20	25		
	(cv)	2.9	4.0	6.7	13.4	14.7	14.7	16.8	20.1	26.8	33.5		

Note: 1) In order to achieve acceptable reliability for application and/or continuity test on the power contacts, a minimum voltage and current of 50 V and 100 mA, respectively, must be used. For lower values, the auxiliary contacts must be used.

Main Contacts

Models	Utilization category AC-1										
	CWBS9	CWBS12	CWBS18	CWBS25	CWBS32	CWBS38	CWBS40	CWBS50	CWBS65	CWBS80	
	3P (NO)										
Conventional thermal current I_{th} ($\theta \leq 55^\circ\text{C}$) (A)	25	25	32	40	50	50	60	90	110	110	
Maximum orientative operational current according to the ambient temperature $\theta \leq 60^\circ\text{C}$ ($U_e \leq 690\text{V}$) (A)	25	25	32	40	50	50	60	90	110	110	
Maximum operational power $\theta \leq 55^\circ\text{C}$ (three-phase resistors)	220/230 V (kW)	9.5	9.5	12	15	19	19	22.5	34	42	42
	380/400 V (kW)	16.5	16.5	21	26	33	33	39.5	59	72.5	72.5
	415/440 V (kW)	19	19	24.5	30.5	38	38	45.5	68.5	84	84
	500 V (kW)	21.5	21.5	27.5	34.5	43	43	52	77	95	95
Actual values for connections	2 poles in parallel	$I_e \times 1.7$									
	3 poles in parallel	$I_e \times 2.4$									
Percentage of maximum operational current	600 ops./h (%)	100	100	100	100	100	100	100	100	100	100

Auxiliary Contacts

Models	CWBS9...80 (built-in)		BFBS (Front mounted blocks)	
Compliance with the standards	IEC 60947-5-1			
Rated insulation voltage U_i (pollution degree 3)	IEC/EN 60947-4-1, VDE 0660 (V)	690		
	UL, CSA (V)	600		
Rated operational voltage U_e	IEC/EN 60947-4-1, VDE 0660 (V)	690		
	UL, CSA (V)	600		
Conventional thermal current I_{th} ($\theta \leq 55^\circ\text{C}$) (A)	10			
Rated operational current I_e	220/230 V (A)	10		
	380/440 V (A)	4		
	500 V (A)	2.5		
	660/690 V (A)	1.5		
DC-13 (IEC/EN 60947-5-1)	24 V (A)	4		
	48 V (A)	2		
	110 V (A)	0.7		
	220 V (A)	0.3		
	440 V (A)	0.15		
Making capacity $U_e \leq 690\text{V}$ 50/60 Hz - AC-15 (A)	$10 \times I_e$			
Breaking capacity $U_e \leq 400\text{V}$ 50/60 Hz - AC-15 (A)	$1 \times I_e$			
Short circuit protection with fuse (gL/gG) (A)	10			
Control circuit reliability (V / mA)	17 / 5			
Electrical life (millions of operations)	1			
Mechanical life (millions of operations)	10			
Non-overlapping time between NO and NC contacts (ms)	1.5			
Impedance of the contacts (m Ω)	2.5			

CWBS

Technical Data

Terminal Capacity and Tightening Torque

			Conductor cross-section			
			Power circuit			
Model			CWBS9...18	CWBS25...38	CWBS40...80	
Mounting system screw type			Phillips number 2	Phillips number 2	ALLEN 4 mm	
Flexible conductor without terminal	AWG		1 x 16-10 2 x 16-10	1 x 16-10 2 x 16-10	1 x 14-3 2 x 14-3	
Flexible conductor with terminal	AWG		1 x 16-10 2 x 16-12	1 x 16-8 2 x 16-10	1 x 14-3 2 x 14-3	
Solid wire	AWG		1 x 16-10 2 x 16-10	1 x 14-18 2 x 14-18	1 x 14-3 2 x 14-3	
Tightening torque	(Nm)		1.7	2.5	5.0	
Control and auxiliary circuit						
Models			CWBS9...38	CWBS40...80		
Mounting system screw type			Phillips number 2	Phillips number 2		
Flexible conductor without terminal	AWG		1 x 16-12 2 x 16-12	1 x 16-12 2 x 16-12		
Flexible conductor with terminal	AWG		1 x 16-12 2 x 16-14	1 x 16-12 2 x 16-14		
Solid wire	AWG		1 x 16-12 2 x 16-12	1 x 16-12 2 x 16-12		
Tightening torque	(Nm)		1.0	1.0		
Auxiliary contact blocks				BFB (front)	BLB (side)	
Models			Phillips number 2			
Mounting system screw type			Phillips number 2			
Conductor cross-section						
Flexible conductor without terminal	AWG		1 x 16-14 2 x 16-14			
Flexible conductor with terminal	AWG		1 x 16-14 2 x 16-14			
Solid wire	AWG		1 x 16-14 2 x 16-14			
Tightening torque	(Nm)		1.0			



Dimensions (mm)

CWBS9...38 Safety Contactors

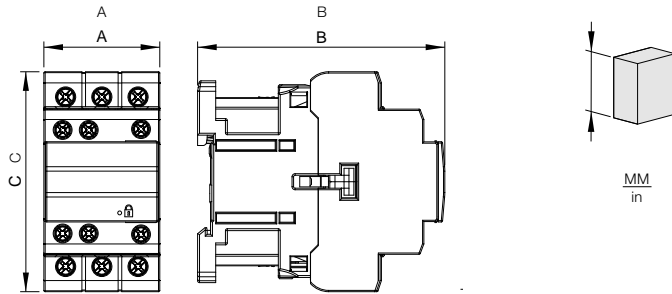

mm in	CWBS9-18 AC	CWBS9-18 DC	CWBS25-38 AC + cover	CWBS25-38 DC + cover
	AC (~)	DC (—)	AC (~)	DC (—)
A	45 1,772			
B	89.5 3,524	98.3 3,870	95.6 3,764	104.8 4,126
C	78.4 3,087		85 3,346	

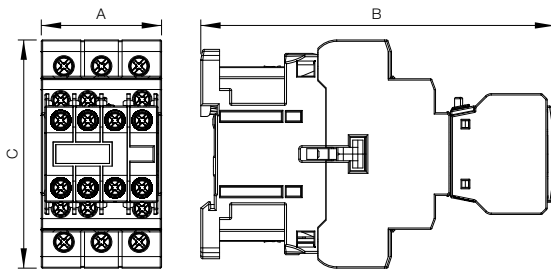
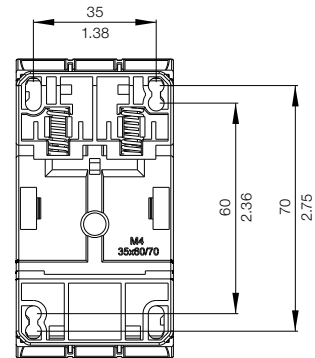

mm in	(CWBS9-18 AC) + BFBS	(CWBS9-18 DC) + BFBS	CWBS25-38 AC + BFBS	CWBS25-38 DC + BFBS
	AC (~)	DC (—)	AC (~)	DC (—)
A	45 1,772			
B	125.8 4,953	134.6 5,299	131.9 5,193	141.1 5,555
C	78.4 3,087		85 3,346	

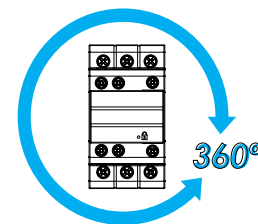
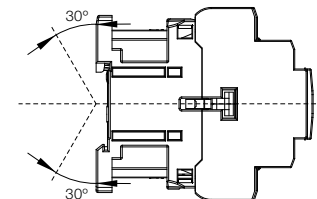

General Information

Circuit Protection

Disconnect Switches

Motor Protectors

Contactors

Overloads

Enclosed Starters

Relays

Pushbuttons and Pilot Lights

Terminal Blocks

Power Factor Correction

Appendix A

Appendix B

Contactors

CWBS

Dimensions (mm)

CWBS40...80 Safety Contactors

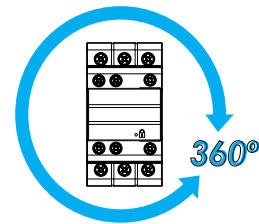
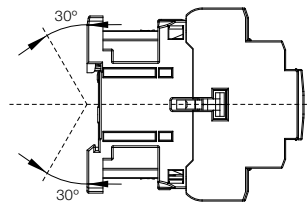
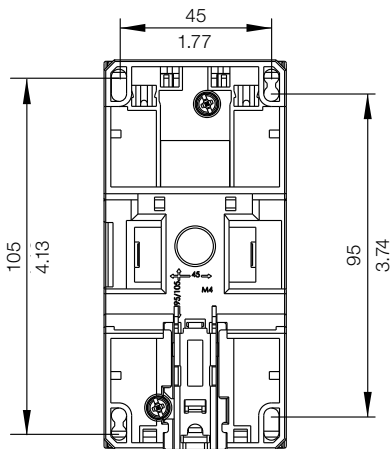
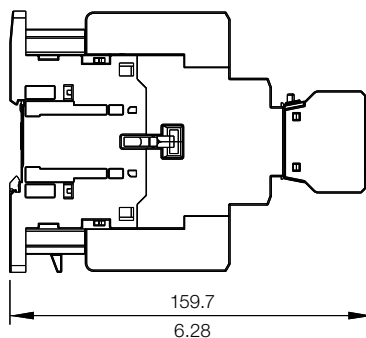
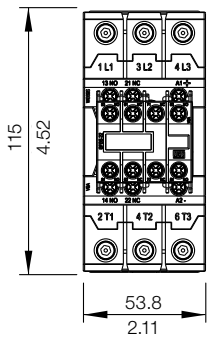
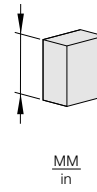
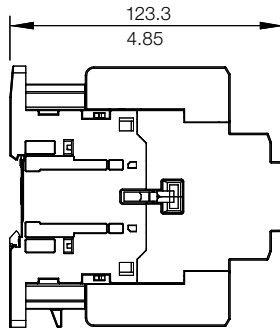
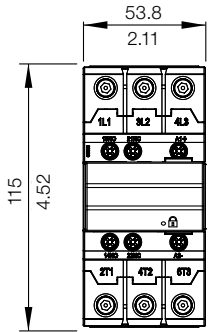

General Information

Circuit Protection

Disconnect Switches

Motor Protectors

Contactors

Overloads

Enclosed Starters

Relays

Pushbuttons and Pilot Lights

Terminal Blocks

Power Factor Correction

Appendix A

Appendix B

CWM Series

The CWM Series IEC Contactor was designed as a general purpose contactor taking into consideration the heavy demands and need for high reliability in modern industry. They are rated for inductive loads up to 800 AMPS @ 460V. CWM Contactors are compact in frame size allowing for optimization of valuable internal space within electrical enclosures. Reducing inventory is a “Snap” away with the CWM Series’ common accessories.

Standard Features

- Panel mountable or 35mm DIN Rail up to the CWM105 Series
- Front and Side Mounting Auxiliary Contacts
- Finger-Touch IP20 Protection
- Wide Coil Voltage Protection AC or DC
- Mirror Contacts for “Safety-Related” Applications
- Mechanically linked Auxiliary Contacts



UL File No. E202315

CWM Catalog Number Sequence

CWM 18 - 10 - 30 V18

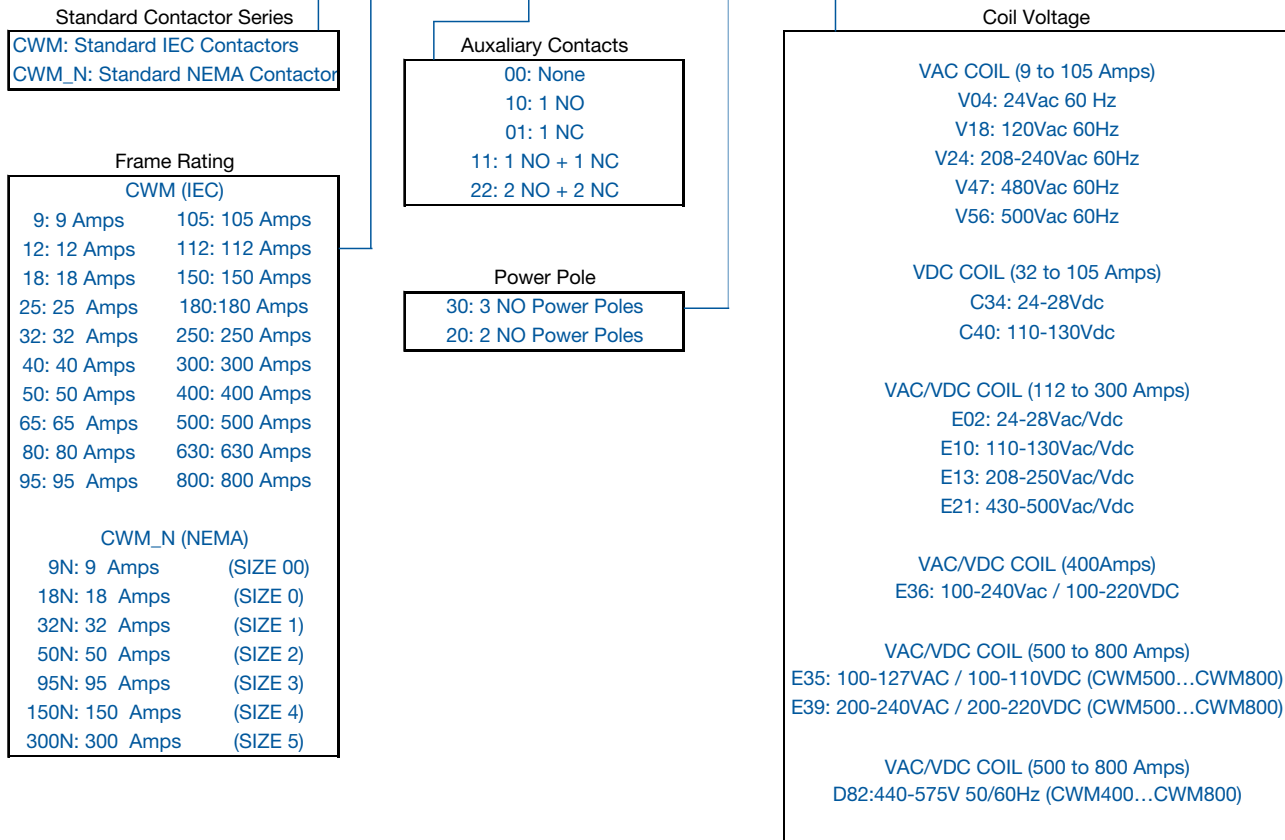

- General Information
- Circuit Protection
- Disconnect Switches
- Motor Protectors
- Contactors
- Overloads
- Enclosed Starters
- Relays
- Pushbuttons and Pilot Lights
- Terminal Blocks
- Power Factor Correction
- Appendix A
- Appendix B

CWM Series - IEC Standard Contactors

General Information

Circuit Protection

Disconnect Switches

Motor Protectors

Contactors

Overloads

Enclosed Starters

Relays

Pushbuttons and Pilot Lights

Terminal Blocks

Power Factor Correction

Appendix A
Appendix B



Catalog Number	CWM9	CWM12	CWM18	CWM25	CWM32	CWM40	CWM50	CWM65	CWM80	CWM95	CWM105
----------------	------	-------	-------	-------	-------	-------	-------	-------	-------	-------	--------

Rated operational power Single-phase

115Vac	Hp	1/2	3/4	1	2	3	3	3	5	7 1/2	7 1/2	10
230Vac	Hp	1 1/2	2	3	5	5	5	7 1/2	10	15	15	20

Three-phase

230Vac	Hp	3	3	5	7 1/2	10	15	15	20	25	30	40
460Vac	Hp	5	7 1/2	10	15	20	30	40	50	50	60	75
575Vac	Hp	7 1/2	10	15	15	25	25	40	50	60	75	75

General Purpose A Rating (AC-1)

Inductive Motor Switching (AC-3)

Overload relays	RW27-1D	0.28...0.4 0.4...0.63 0.56...0.8 0.8...1.2 1.2...1.8 1.8...2.8 2.8...4 4...6.3	5.6...8 7...10 8...12.5 10...15 11...17 15...23 22...32	RW67-1D	25...40 32...50	RW67-2D	40...57 50...63 57...70 63...80	RW117-1D	63...80 75...97 90...112
-----------------	---------	---	---	---------	--------------------	---------	--	----------	--------------------------------

Auxiliary contact blocks



BCXMF10 (1NO)
BCXMF01 (1NC)



BCXML 11 (1NO+1NC)
BCXML 20 (2NO)
BCXMR 11 (1NO+1NC)
BCXMR 20 (2NO)

Mechanical interlock



BLIM9-105
BLIM.02 9-105 (2NC)

Electronic Relays



Timing Relays - RTW Series
(Please refer to Electronic Relays Section)

Surge Suppressor



RC block:
BAMRC4 D53 24-48 V 50/60Hz
BAMRC5 D55 50-127 V 50/60Hz
BAMRC6 D63 130-250 V 50/60Hz

Varistor block:
BAMV1 D68 270-380 V 50/60Hz
BAMV2 D73 400-510 V 50/60Hz



RC block:
BAMRC7 D53 24-48 V 50/60Hz
BAMRC8 D55 50-127 V 50/60Hz
BAMRC9 D63 130-250 V 50/60Hz

Varistor block:
BAMV1 D68 270-380 V 50/60Hz
BAMV2 D73 400-510 V 50/60Hz

CWM Series - IEC Standard Contactors



Catalog Number	3 Poles	CWM112	CWM150	CWM180	CWM250	CWM300
----------------	---------	--------	--------	--------	--------	--------

Rated operational power

Single-phase

115Vac	Hp	-	-	-	-	-
230Vac	Hp	-	-	-	-	-

Three-phase

230Vac	Hp	50	60	75	100	125
460Vac	Hp	100	125	150	200	250
575Vac	Hp	100	150	200	250	350

General Purpose Rating	A	180	225	225	350	410
------------------------	---	-----	-----	-----	-----	-----

Inductive/Motor Switching (AC3)		112	150	180	250	300
---------------------------------	--	-----	-----	-----	-----	-----

Overload relays	RW117-2D		75...97 90...112	RW317-1D		100...150 140...215 200...310 275...420
-----------------	----------	--	---------------------	----------	---	--

Auxiliary contact blocks		BCXML11 (1NO+1NC) BCXML20 (2NO) BCXMRL11 (1NO+1NC) BCXMRL20 (2NO)
--------------------------	---	--

Mechanical interlock		BLIM112-300
----------------------	--	-------------

Surge suppressor	built-in with electronic module					
------------------	---------------------------------	--	--	--	--	--

General Information

Circuit Protection

Disconnect Switches

Motor Protectors

Contactors

Overloads

Enclosed Starters

Relays

Pushbuttons and Pilot Lights

Terminal Blocks

Power Factor Correction

Appendix A

Appendix B

CWM Series - IEC Standard Contactors

General Information

Circuit Protection

Disconnect Switches

Motor Protectors

Contactors

Overloads

Enclosed Starters

Relays

Pushbuttons and Pilot Lights

Terminal Blocks

Power Factor Correction

Appendix A

Appendix B



Catalog Number		CWM400	CWM630	CWM800
Rated Optional Power				
Single-phase				
220/230Vac	Hp	-	-	-
380Vac	Hp	-	-	-
Three-phase				
230Vac	Hp	150	250	300
460Vac	Hp	300	500	600
575Vac	Hp	300	500	600
General Purpose Rating	A	450	660	900
Inductive/Motor Switching AC-3		400	630	800

Overload relays	A	RW407-1D		400...600 560...840
-----------------	---	-----------------	--	------------------------

Auxiliary contact blocks			BCXML11 CWM800 (1NO+1NC) BCXMRL11 CWM800 (1NO+1NC)
--------------------------	--	--	---

Mechanical interlock				BLIM CWM400 BLIM CWM800
----------------------	--	--	--	----------------------------

Surge suppressor		(Built-in with electronic module)		
------------------	--	-----------------------------------	--	--

3 pole contactors with AC coil



Maximum UL Horsepower						Auxiliary Contacts		Current Rating Amps	Catalog Number ¹	List Price	Multiplier
Single Phase		Three Phase				N.O.	N.C.				
115V	230V	200V	230V	460V	575V						
1/2	1 1/2	3	3	5	7 1/2	1	0	9	CWM9-10-30*	\$72	Z1
						0	1		CWM9-01-30*		
3/4	2	3	3	7 1/2	10	1	0	12	CWM12-10-30*	\$89	
						0	1		CWM12-01-30*		
1	3	5	5	10	15	1	0	18	CWM18-10-30*	\$103	
						0	1		CWM18-01-30*		
2	5	7 1/2	7 1/2	15	15	0	0	25	CWM25-00-30*	\$118	
3	5	10	10	20	25	0	0	32	CWM32-00-30*	\$140	
3	7 1/2	10	15	30	25	0	0	40	CWM40-00-30*	\$164	
3	10	15	15	40	40	0	0	50	CWM50-00-30*	\$225	
5	10	20	20	50	50	0	0	65	CWM65-00-30*	\$255	
7 1/2	15	20	25	50	60	0	0	80	CWM80-00-30*	\$270	
7 1/2	15	25	30	60	75	0	0	95	CWM95-00-30*	\$365	
10	20	30	40	75	75	0	0	105	CWM105-00-30*	\$393	

Note:

1) For other auxiliary contact configurations, please refer to page 193.

To complete the selection

- Replace "*" with desired coil voltage from Coil Voltage Code Table

* AC COIL VOLTAGE CODE SELECTION FOR CONTACTORS CWM9...CWM105						
60 Hz	24V	48V	120V	208-240V	480V	600V
CODE	V04	V10	V18	V24	V47	V56
50 Hz	20V	42V	110V	180-208	400-415V	500V

- Other coil voltages available upon request

The Flexible Line from 5 to 75HP

The 5 to 75HP @ 460V range is differentiated by five frame sizes and only 4 varying widths, with the choice of either screw or DIN rail mounting. WEG offers one of the most compact 75HP @ 460V contactors in the market.

Coil Technology

WEG Contactor AC coils have 4 terminals up to 30HP @ 460V, which allows an easy connection no matter the complexity of the application and wiring. From 32A up to 105A the contactors are equipped with an electronic circuit that provides an unmatched space saving solution, making the 50A through 105A contactors depth the same size.

- General Information
- Circuit Protection
- Disconnect Switches
- Motor Protectors
- Contactors**
- Overloads
- Enclosed Starters
- Relays
- Pushbuttons and Pilot Lights
- Terminal Blocks
- Power Factor Correction
- Appendix A
- Appendix B

CWM Series - IEC Standard Contactors

3 pole contactors with DC coil



Maximum UL Horsepower						Auxiliary Contacts		Current Rating Amps	Catalog Number	List Price	Multiplier
Single Phase		Three Phase				N.O.	N.C.				
115V	230V	200V	230V	460V	575V						
3	5	10	10	20	25	0	0	32	CWM32-00-30+	\$220	Z1
3	7 1/2	10	15	30	25	0	0	40	CWM40-00-30+	\$282	
3	10	15	15	40	40	0	0	50	CWM50-00-30+	\$310	
5	10	20	20	50	50	0	0	65	CWM65-00-30+	\$350	
7 1/2	15	20	25	50	60	0	0	80	CWM80-00-30+	\$417	
7 1/2	15	25	30	60	75	0	0	95	CWM95-00-30+	\$450	
10	20	30	40	75	75	0	0	105	CWM105-00-30+	\$540	

- For other auxiliary contact configurations please refer to page 193.

To complete the selection

- Replace "+" with desired coil voltage from Coil Voltage Code Table

+ DC COIL VOLTAGE CODE SELECTION FOR CONTACTORS CWM32...105

FOR CONTACTORS CWM32...CWM105

Voltage	24-28V	110-130V
CODE	C34	C40

General Information

Circuit Protection

Disconnect Switches

Motor Protectors

Contactors

Overloads

Enclosed Starters

Relays

Pushbuttons and Pilot Lights

Terminal Blocks

Power Factor Correction

Appendix A

Appendix B

3 pole contactors with AC/DC electronic module coil



Maximum UL Horsepower						Auxiliary Contacts		Current Rating Amps	Catalog Number	List Price	Multiplier
Single Phase		Three Phase									
115V	230V	200V	230V	460V	575V	N.O.	N.C.				
-	-	40	50	100	100	2	2	112	CWM112-22-30#	\$865	Z1
-	-	50	60	125	150	2	2	150	CWM150-22-30#	\$960	
-	-	60	75	150	200	2	2	180	CWM180-22-30#	\$1,350	
-	-	75	100	200	250	2	2	250	CWM250-22-30#	\$1,920	
-	-	100	125	250	300	2	2	300	CWM300-22-30#	\$2,150	
-	-	125	150	300	300	2	2	400	CWM400-22-30^	\$2,950	
-	-	200	250	500	500	2	2	630	CWM630-22-30^	\$4,460	
-	-	200	300	600	600	2	2	800	CWM800-22-30^	\$6,530	

- For different auxiliary contact configurations please refer to page 193.

To complete the selection

- Replace “#” or “^” with desired coil voltage from Coil Voltage Code Table

AC/DC COIL VOLTAGE CODE SELECTION FOR CONTACTORS CWM112, 150, 180, 250, 300

Voltage (50/60Hz)	24-28Vac/Vdc	110-130Vac/Vdc	208-250Vac/Vdc	430-500Vac/Vdc
CODE	E02	E10	E13	E21
Mounting on	CWM112-CWM300	CWM112-CWM300	CWM112-CWM300	CWM112-CWM300

^ AC/DC COIL VOLTAGE CODE SELECTION FOR CONTACTORS CWM400...800

Voltage	100-240Vac/100-220Vdc	100-127Vac/100-110Vdc	200-240Vac/200-220Vdc	440-575V 50/60 Hz
CODE	E36	E35	E39	D82
Mounting on	CWM400	CWM630-CWM800	CWM630-CWM800	CWM400-CWM800

The Tough Line from 100 to 600HP

With reliability as our goal, WEG contactors are modern and very compact, but they are also one of the most rugged line of contactors in the range from 100 to 600HP, assuring an extended life under the most challenging conditions of today’s industry.

Accessories

Side mounted auxiliary contact blocks are common for all CWM contactors, from 5 to 250HP @ 460V.

Electronic Module

From 100 to 600HP @ 460V, WEG offers contactors with electronic module for AC/DC Coil Applications. Such coils provide a smoother switching, therefore enhancing contactor’s performance. Built-in surge suppressor is also standard.

- General Information
- Circuit Protection
- Disconnect Switches
- Motor Protectors
- Contactors
- Overloads
- Enclosed Starters
- Relays
- Pushbuttons and Pilot Lights
- Terminal Blocks
- Power Factor Correction
- Appendix A
- Appendix B

CWM Series - IEC Standard Contactors

2 pole contactors with AC coil

Circuit Protection	Maximum UL Horsepower		Auxiliary Contacts		Current Rating Amps	Catalog Number	List Price	Multiplier	
	Single Phase		N.O.	N.C.					
	115V	230V							
Disconnect Switches	1/2	1 1/2	0	0	9	CWM9-00-20*	\$65	Z1	
	3/4	2	0	0	12	CWM12-00-20*	\$68		
	1	3	0	0	18	CWM18-00-20*	\$73		
	2	5	0	0	25	CWM25-00-20*	\$99		
	3	5	0	0	32	CWM32-00-20*	\$126		
Motor Protectors	3	7 1/2	0	0	40	CWM40-00-20*	\$160		Z1
	3	10	0	0	50	CWM50-00-20*	\$174		
	5	10	0	0	65	CWM65-00-20*	\$200		
	7 1/2	15	0	0	80	CWM80-00-20*	\$231		
	7 1/2	15	0	0	95	CWM95-00-20*	\$300		
Contactors	10	20	0	0	105	CWM105-00-20*	\$321	Z1	

- For other auxiliary contact configurations please refer to page 193

To complete the selection

- Replace "*" with desired coil voltage from Coil Voltage Code Table

FOR CONTACTORS CWM9...CWM105

* AC COIL VOLTAGE CODE SELECTION

60 Hz	24V	120V	208-240V
CODE	V04	V18	V24
50 Hz	20	110V	180-208

General Information

Circuit Protection

Disconnect Switches

Motor Protectors

Contactors

Overloads

Enclosed Starters

Relays

Pushbuttons and Pilot Lights

Terminal Blocks

Power Factor Correction

Appendix A

Appendix B

CWM-N Series - NEMA Rated Standard Contactor

The WEG CWM_N series NEMA rated contactor line has been designed for industrial duty and with reliability in mind. Rated for inductive loads up to 300 Amps or 200 Hp @ 460V, WEG can offer the suitable contactor for your application.

Customers who are used to specifying contactors (and starters), by a particular NEMA Size (size 00, 0, 1, 2, 3, 4, 5), now can use the WEG CWM_N series, NEMA rated contactors. Customers get the ease of choosing the product, the reliability of WEG quality, and still get the sophisticated arc quenching techniques to reduce excess heat on the contacts.

Given their compact footprints, CWM_N contactors allow total panel space optimization, with only a few compact frame sizes from 5 to 200 Hp @ 460 V. Reducing inventory is a “snap” with CWM’s common accessories. For example, side mounted auxiliary contact blocks are the same from 5 to 200 Hp @ 460 V.



UL File No. E202315

Standard Features:

- Ease of choosing product
- Compact footprint
- Arc Quenching technique
- Reduced inventory with common accessories
- Adjustable thermal overload relay for motor protection
- Reliable WEG Quality

NEMA Size	NEMA Continuous Amp rating	WEG Continuous Amp rating	HP @ 230 V	HP @ 460 V
00	9	9	1.5	2
0	18	18	3	5
1	27	32	7.5	10
2	45	50	15	25
3	90	95	30	50
4	135	150	50	100
5	270	300	100	200

- General Information
- Circuit Protection
- Disconnect Switches
- Motor Protectors
- Contactors
- Overloads
- Enclosed Starters
- Relays
- Pushbuttons and Pilot Lights
- Terminal Blocks
- Power Factor Correction
- Appendix A
- Appendix B

CWM-N Series - NEMA Rated Standard Contactor

General Information

Circuit Protection

Disconnect Switches

Motor Protectors

Contactors

Overloads

Enclosed Starters

Relays

Pushbuttons and Pilot Lights

Terminal Blocks

Power Factor Correction

Appendix A
Appendix B

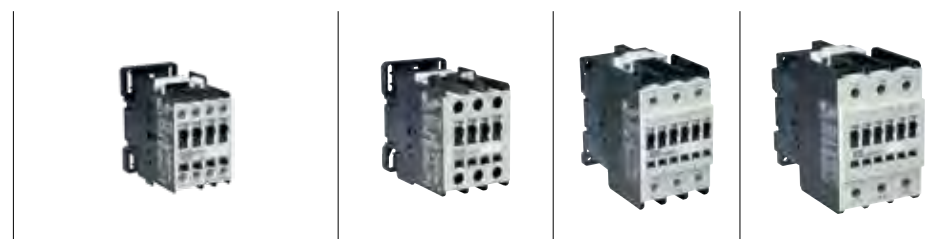

Catalog Number	CWM9N	CWM18N	CWM32N	CWM50N	CWM95N
NEMA Size	00	0	1	2	3
Rated operational power ¹					
Single-phase					
115Vac Hp	1/3	1	3	3	7 1/2
230Vac Hp	1	3	5	7 1/2	15
Three-phase					
230Vac Hp	1 1/2	3	7 1/2	15	30
460Vac Hp	2	5	10	25	50
575Vac Hp	2	5	10	25	50
General Purpose A Rating	25	32	60	90	140

Overload Relays	RWM40E	<p>0.4 ... 2.0 1.6 ... 8.0 5 ... 25 8 ... 40</p>	RWM112E	<p>14 ... 56 28 ... 112</p>
------------------------	---------------	--	----------------	---------------------------------





Auxiliary contact blocks	<p>BCXMF10 (1NO) BCXMF01 (1NC)</p>	<p>BCXML 11 (1NO+1NC) BCXML 20 (2NO) BCXMR 11 (1NO+1NC) BCXMR 20 (2NO)</p>
---------------------------------	--	--

Mechanical interlock	<p>BLIM9-105 BLIM.02 9-105 (2NC)</p>
-----------------------------	--

Electronic Relays	<p>Timing Relays - RTW Series (Please refer to page 264)</p>
--------------------------	---

Surge suppressor	<p>RC block: BAMRC4 D53 24-48 V 50/60Hz BAMRC5 D55 50-127 V 50/60Hz BAMRC6 D63 130-250 V 50/60Hz</p> <p>Varistor block: BAMV1 D68 270-380 V 50/60Hz BAMV2 D73 400-510 V 50/60Hz</p>	<p>RC block: BAMRC7 D53 24-48 V 50/60Hz BAMRC8 D55 50-127 V 50/60Hz BAMRC9 D63 130-250 V 50/60Hz</p> <p>Varistor block: BAMV1 D68 270-380 V 50/60Hz BAMV2 D73 400-510 V 50/60Hz</p>
-------------------------	---	---

CWM-N Series - NEMA Rated Standard Contactor

			
Catalog Number	3 Poles	CWM150N	CWM300N
NEMA Sizes		4	5
Rated operational power¹⁾			
Single-phase			
115Vac	Hp	-	-
230Vac	Hp	-	-
Three Phase			
230Vac	Hp	50	100
460Vac	Hp	100	200
575Vac	Hp	100	200
General Purpose Rating	A	225	410
Solid State Overload relays	A	RWM420E  50...250 85...420	
Auxiliary contact blocks		 BCXML11 (1NO+1NC) BCXML20 (2NO) BCXMR11 (1NO+1NC) BCXMR20 (2NO)	
Mechanical interlock		 BLIM112-300	
Surge suppressor		built-in with electronic module	

1) Note: Some motors characteristics may vary according to each manufacturer.

General Information

Circuit Protection

Disconnect Switches

Motor Protectors

Contactors

Overloads

Enclosed Starters

Relays

Pushbuttons and Pilot Lights

Terminal Blocks

Power Factor Correction

Appendix A

Appendix B

CWM-N Series - NEMA Rated Standard Contactor

3 POLE NEMA CONTACTORS WITH AC COIL



NEMA Size	Maximum UL Horsepower						Auxiliary Contacts		Current Rating Amps	Catalog Number	List Price	Multiplier
	Single Phase		Three Phase				N.O.	N.C.				
	115V	230V	200V	230V	460V	575V						
00	1/3	1	1.5	1.5	2	2	1	0	9	CWM9N-10-30*	\$103	Z1
							0	1		CWM9N-01-30*		
0	1	2	3	3	5	5	1	0	18	CWM18N-10-30*	\$118	
							0	1		CWM18N-01-30*		
1	2	3	7.5	7.5	10	10	0	0	32	CWM32N-00-30*	\$164	
2	3	7.5	10	15	25	25	0	0	50	CWM50N-00-30*	\$233	
3	7.5	15	25	30	50	50	0	0	95	CWM95N-00-30*	\$384	
4	-	-	40	50	100	100	2	2	150	CWM150N-22-30#	\$1,350	
5	-	-	75	100	200	200	2	2	300	CWM300N-22-30#	\$2,300	

- For additional auxiliary contacts, see page 193.

* AC COIL VOLTAGE CODE SELECTION

FOR CONTACTORS CWM9N...CWM95N

60 Hz	24V	120V	208-240V	480V	600V
CODE	V04	V18	V24	V47	V56
50 Hz	20V	110V	180-208V	400-415V	500V

AC / DC COIL VOLTAGE CODE SELECTION

FOR CONTACTORS: CWM150N, CWM300N



Voltage (50/60Hz)	24-28 Vac/Vdc	110-130 Vac/Vdc	208-250 Vac/Vdc	430-500 VAC/VDC
CODE	E02	E10	E13	E21

Notes:



- 1) CWM_N Series - 9 to 95 A - AC COIL
- 2) CWM_N Series - 150 to 300 A - AC/DC Coil with Electronic Module

CWM-N Series - NEMA Rated Standard Contactor

Accessories

Auxiliary Contacts Block							
Location/Description	Mounting on Contactors	Auxiliary Contacts		Catalog Number	List Price	Multiplier	
		N.O.	N.C.				
	Front Mounting	CWM9...105	1	0	BCXMF10	\$10	Z1
		CWM9N...95N	0	1	BCXMF01	\$10	
	Side Mounting	CWM9...CWM300 CWM9N...300N	1	1	BCXML11	\$22	
			2	0	BCXML20	\$22	
Side Mounting, Second Block			1	1	BCXMRL11	\$22	
			2	0	BCXMRL20	\$22	
Side Mounting		CWM400...CWM800	1	1	BCXML11 CWM800	\$65	
			1	1	BCXMRL11 CWM800	\$65	

Maximum # of added auxiliary contacts per contactor frame size: Note that side mountable version has 2 aux. contacts per block. CWM9...25 = 4 aux. contacts; CWM32...40 = 6 aux. contacts; CWM50...300E = 8 aux. contacts.

Mechanical Interlock Block							
Location/Description	Mounting on Contactors	Auxiliary Contacts		Catalog Number	List Price	Multiplier	
		N.O.	N.C.				
	Side mounted between two contactors	CWM9...105 CWM9N...95N	0	0	BLIM 9-105	\$29	Z1
			0	2	BLIM.02 9-105	\$40	
		CWM112...300 1CWM150N CWM300N	0	0	BLIM 112-300	\$77	
			0	0	BLIM CWM400	\$63	
	Bottom mounted	CWM630...CWM800	0	0	BLIM CWM800	\$1,850	

Notes: For CWM9...CWM105 the mechanical interlock can be used to interlock different frame sizes. For CWM112...CWM300, the mechanical interlock has to be used with contactors that have the same mechanical frame size.

For BLIM CWM800, a metal mount base is provided with this accessory for an accurate assembling of the contactors.

Surge Suppressors						
Description	Mounting on Contactors	Voltage Range	Catalog Number	List Price	Multiplier	
	Limits switching transients from contactor pick-up	CWM9...40 CWM9N...32N	24...48Vac	BAMRC4 D53	\$30	Z1
			50...127Vac	BAMRC5 D55	\$30	
			130...250Vac	BAMRC6 D63	\$30	
		CWM50...105 CWM50N...95N	24...48Vac	BAMRC7 D53	\$30	
			50...127Vac	BAMRC8 D55	\$30	
			130...250Vac	BAMRC9 D63	\$30	
		CWM9...105 CWM9N...95N	270 - 380Vac	BAMV1 D68	\$30	
			400 - 510Vac	BAMV2 D73	\$30	

Note: CWM112...300 with Electronic Module and CWM400...800 already have the surge suppressor built-in on the electronic module

- General Information
- Circuit Protection
- Disconnect Switches
- Motor Protectors
- Contactor's
- Overloads
- Enclosed Starters
- Relays
- Pushbuttons and Pilot Lights
- Terminal Blocks
- Power Factor Correction
- Appendix A
- Appendix B

CWM Series - IEC Standard Contactors

Accessories

Terminal Cover for CWM_E Contactor Series

Location/Description	Mounting on Contactors	Catalog Number	List Price	Multiplier
 Protection for contactor terminals (2 covers per package)	CWM150	BMP CWM150	\$125	Z1
	CWM180	BMP CWM180	\$125	
	CWM300	BMP CWM300	\$125	
	CWM400	BMP CWM400	\$60	
	CWM630...CWM800	BMP CWM800	\$110	

Lugs for CWM Contactor Series (3 units per package)

Description / Wire Range	Mounting on Contactors	Catalog Number	List Price	Multiplier
 300 MCM...6 AWG 300 MCM...6 AWG 600 MCM...4 AWG (2) 3-4/0 AWG (2) 3/0-600 MCM	CWM112...150	LW1-S300	\$52	Z1
	CWM180	LW2-S300	\$52	
	CWM250...CWM300	LW1-S600	\$110	
	CWM400	BMJ CWM400	\$98	
	CWM630...CWM800	BMJ CWM800	\$158	

Connector links (3 per package)

Description	Contactor	Overload Relay	Catalog Number	List Price	Multiplier
 Link connectors for easier CWM contactors and RW overload relays assembly	CWM112	RW117-2D3	GA117D	\$41	Z2
	CWM150	RW317-1D3	GA317-1D	\$68	
	CWM180	RW317-1D3	GA317-2D	\$70	
	CWM250 / CWM300	RW317-1D3	GA317-3D	\$118	
	CWM400	RW317-1D3	GA317-10D	\$118	

Contact Set

Description	Part Number	Mounting On	List Price	Multiplier
One set consists of all parts required to rebuild one 3 pole contactor.	JC CWM112-3P	CWM112	\$335.00	Z1
	JC CWM150E-3P	CWM150	\$376.00	
	JC CWM180-3P	CWM180	\$525.00	
	JC CWM250-3P	CWM250	\$1,120.00	
	JC CWM300E-3P	CWM300	\$1,190.00	
	JC CWM400-3P	CWM400	\$908.00	
	JC CWM630-3P	CWM630	\$946.00	
JC CWM800-3P	CWM800	\$983.00		

Replacement Coil

Description		Mounting on Contactors	Catalog Number	List Price	Multiplier	
	Coil voltage code is required to complete part number	AC COIL				
		CWM9...25 CWM9N...18N	BCA4-25*	\$28	Z1	
		CWM32...40 CWM32N	BCA4-40*	\$35		
		CWM50...105 CWM50N...95N	BCA-105*	\$44		
		DC COIL²				
		CWM32...40	BECC4-40+	\$100	Z1	
		CWM50...105	BECC-105+	\$60		
		AC/DC ELECTRONIC MODULE & COIL¹				
		CWM112...150 CWM150N	BCE-150# ME-300#	\$90 \$215	Z1	
		CWM180	BCE-215# ME-300#	\$118 \$260		
		CWM250...300 CWM300N	BCE-300# ME-300#	\$146 \$260		
		CWM400	BCE-400 ^	\$700		
		CWM630...800	BCE-800 ^	\$850		

1) Module (ME-) & Coil (BCE-) must be used together for a proper contactor operation.

2) DC Option does not include NEMA Rated Contactors

* AC COIL VOLTAGE CODE SELECTION FOR CONTACTORS CWM9...CWM105, CWM150N, CWM300N, CWM9N...95

60 Hz	24V	48V	120V	208-240V	277V	480V	600V
CODE	V04	V10	V18	V24	V37	V47	V56
50 Hz	20V	42V	110V	180-208V	230-240V	400-415V	500V

+ DC COIL VOLTAGE CODE SELECTION³⁾

FOR CONTACTORS CWM32...CWM105

Voltage	24-28V	110-130V
CODE	C34	C40

AC/DC COIL VOLTAGE CODE SELECTION - Electronic Contactor Required

FOR CONTACTORS CWM112, 150, 180, 250, 300, CWM150N, CWM300N

Voltage (50/60Hz)	24-28Vac/Vdc	110-130Vac/Vdc	208-250Vac/Vdc	430-500Vac/Vdc
CODE	E02	E10	E13	E21
Mounting on	CWM112-CWM300	CWM112-CWM300	CWM112-CWM300	CWM112-CWM300

^ AC/DC COIL VOLTAGE CODE SELECTION - Electronic Contactor Required

FOR CONTACTORS CWM400, 630, 800

Voltage	100-240Vac/100-220Vdc	100-127Vac/100-110Vdc	200-240Vac/200-220Vdc	440-575V 50/60Hz
CODE	E36	E35	E39	D82
Mounting on	CWM400	CWM630-CWM800	CWM630-CWM800	CWM400-CWM800

3) DC coils cannot be used in AC coil contactors due to difference in size of coil housing.

General Information

Circuit Protection

Disconnect Switches

Motor Protectors

Contactors

Overloads

Enclosed Starters

Relays

Pushbuttons and Pilot Lights

Terminal Blocks

Power Factor Correction

Appendix A

Appendix B

Contactors

Contactors for Capacitor Switching

General Information

Circuit Protection

Disconnect Switches

Motor Protectors

Contactors

Overloads

Enclosed Starters

Relays

Pushbuttons and Pilot Lights

Terminal Blocks

Power Factor Correction

Appendix A

Appendix B

Switching of power factor correction capacitors

WEG's special CWMC contactors series for switching of capacitors is designed according to UL 508 and IEC 60947-1, and provides the best solution for the switching of power factor correction capacitors.

No more in-rush

When switching on a capacitor bank, the capacitors are uncharged and the system sees them as a short circuit for a quick period of time.

The in-rush current is the result of this little short circuit and usually lasts for some milliseconds. It may reach 100 times the rated current which one of the main reasons for the short life of a capacitor.

The CWMC contactor is assembled with damping resistors which limit the high in-rush current when the capacitors are switched on. They are assembled with an early-make contact block which is switched on before the main contacts thus, limiting the in-rush current.

However, the damping resistors don't influence the final load, since they are switched off after 5 milliseconds leaving only the capacitors in parallel with their inductive load providing the proper power factor correction. This process increases the lifetime of the capacitors and also prevents line distortions.

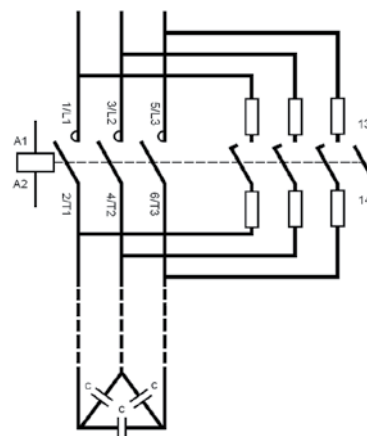

Current on the contacts, without damping resistors

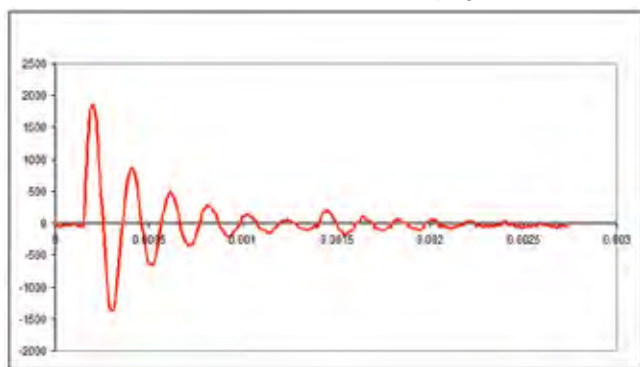

I_u (A) with standard contactors

Current on the contacts, with damping resistors installed

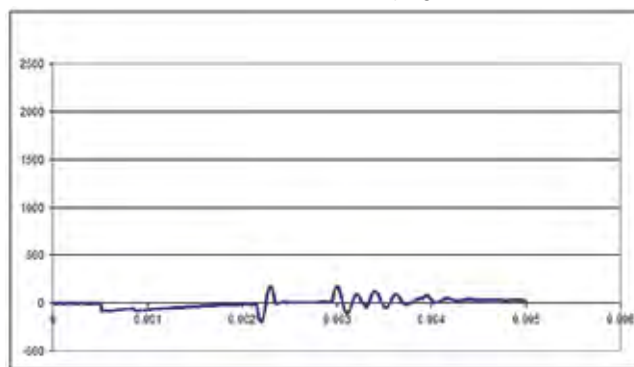

I_u (A) with WEG CWMC contactor

Certifications



Modular design

For 35 mm DIN rail or screw assembly.

Damping resistors

Avoids high in-rush current

Contactor data and certifications

Shows all necessary information of CMMC.

Early make contact block

Connects damping resistors and switches off after 5 ms

Auxiliary Contact

CMMC allows use of standard NO or NC contact blocks, the same used with WEG CWM contactors series

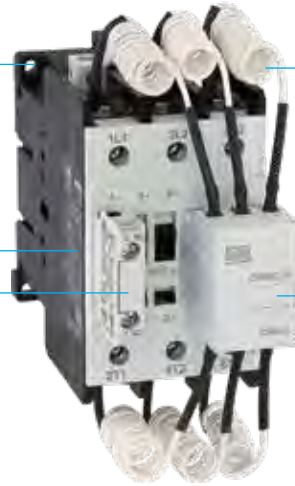

New models

CMMC contactors are available in 5 different models in 3 different frames. All contactors are available with AC coils with a large variety of voltage ranges for 50 or 60 Hz. For DC coils and further information, please contact a WEG representative.

CMMC contactor for switching of capacitors (AC-6b)

Catalog Number	Rated current AC-6b In (A)	Reactive power (kVAr)			List Price	Multiplier
		220-230 Vac	480 Vac	660/690 Vac		
CWMC25-10-30**	30	11	25	34	\$225	Z1
CWMC32-10-30**	40	15	33	45	\$237	Z1
CWMC50-10-30**	60	25	50	65	\$284	Z1
CWMC65-10-30**	77	30	65	87	\$312	Z1
CWMC80-10-30**	93	35	77	106	\$500	Z1

To complete catalog number, replace ** with appropriate coil voltage code

** Complete with the voltage code

X18	X23	X30	X47
120V60Hz	208V60Hz	240V60Hz	480V60Hz

Technical Characteristics

AC COIL		CWMC25	CWMC32	CWMC50	CWMC65
Reactive Power AC-6b @ 55 °C	220 - 230 V	11	15	25	30
	380 - 415 V	20	25	40	50
	440 V	23	30	45	60
	480 V	25	33	50	65
	660 - 690 V	34	45	65	87
AC-6b Current (Ie)	(131°F)	30	40	60	77
Thermal Current (Ith)	(131°F)	45	60	90	110
AC-6b Current (Ie)	(158°F)	22	34	50	62
Max Fuse (gL/gG)		50	63	100	125
Max Fuse Acc. to UL/CSA (J Type)		45	60	100	125
Cable cross section	mm2	2 x 10	2 x 16	2 x 35	2 x 35
	AWG	2 x 8	2 x 6	2 x 2	2 x 2
Tightening torque	Lb-in	14...26	22...35	35...53	35...53
Max. operation per hour	ops/h.	120			
Max. Number of Auxiliary contacts		1	3	5	
Electrical Lifespan	Ops x 103	100	100	100	100
Coil consumption (AC) Pick-up/Sealing	VA	75/9.3	123/12.5	308/25	308/25

CWM Series - IEC Standard Contactors

Control circuit ratings - AC Coil

TYPE	CWM9	CWM12	CWM18	CWM25	CWM32	CWM40	CWM50	CWM65	CWM80	CWM95	CWM105	
Rated Insulation Voltage Ui												
Acc. IEC; VDE 0660 [V]						1000						
Acc. UL; CSA [V]						600						
Rated Operating Voltage Ue												
Acc. IEC; VDE 0660 [V]						690						
Acc. UL; CSA [V]						600						
Standard Voltages 60Hz [V]						24...600						
Coil Operating limits												
Monofrequency coils xUc [V]						0.85...1.1						
Pick-up xUc [V]	0.4...0.76					0.5...0.76		0.5...0.76				
Drop-out xUc [V]	0.25...0.65					0.3...0.65		0.25...0.6				
Operating Time												
Coil energization - N.O. [ms]	8...20					10...19		15...30				
Coil de-energization - N.O. [ms]	6...13					5...25		9...15				
Coil Consumption												
Single coils												
Sealed [VA]	4...7.2					6.6...12.5		13.1...19.1				
Inrush [VA]	70					98		255				
Thermal Power Dissipation												
60Hz [W]	2.6					4.3		8.0				
Power Factor												
Closed Cos phi	0.28					0.34		0.32				
Opened Cos phi	0.85					0.69		0.54				
Stranded / Solid (UL / CSA) [AWG]	2x12-10	2x12-10	2x12-10	2x12-10	2x12-10	2x12-10	2x12-10	2x12-10	2x12-10	2x12-10	2x12-10	

Control circuit ratings - DC Coil

TYPE	CWM9	CWM12	CWM18	CWM25	CWM32	CWM40	CWM50	CWM65	CWM80	CWM95	CWM105	
Rated Insulation Voltage Ui												
Acc. IEC; VDE 0660 [V]						1000						
Acc. UL; CSA [V]						600						
Standard Voltages [V]	12...440					24...240		24...240				
Coil Operating limits												
Pick-up xUc [V]						0.85...1.1						
Drop-out xUc [V]	0.4...0.7 0.15...0.4					0.45...0.75 0.15...0.45		0.7...0.8 0.4...0.6				
Operating Time												
Coil energization - N.O. [ms]	35...45					40...55		50...60				
Coil de-energization - N.O. [ms]	7...12					30...65		55...60				
Coil Consumption												
Sealed [W]	3.8...9.0					6		6.5				
Inrush [W]	3.8...9.0					240		340				
Stranded / Solid (UL / CSA) [AWG]	2x12-10	2x12-10	2x12-10	2x12-10	2x12-10	2x12-10	2x12-10	2x12-10	2x12-10	2x12-10	2x12-10	

CWM Series - IEC Standard Contactors

IEC Contactors - CWM Series

TYPE		CWM112	CWM150	CWM180	CWM250	CWM300	CWM400	CWM630	CWM800	
Rated Insulation Voltage Ui										
Acc. IEC; VDE 0660	[V]				1000					
Acc. UL; CSA	[V]				600					
Rated Operating Voltage Ue										
Acc. IEC; VDE 0660	[V]				690					
Acc. UL; CSA	[V]				600					
Standard Voltages 50Hz; 60Hz; DC	[V]				24...600					
Coil Operating limits										
xUc	[V]	0.8...1.1			0.85...1.1					
Pick-up xUc	[V]	0.6...0.75			0.77...0.83					
Drop-out xUc	[V]	0.40...0.60			0.48...0.53					
Operating Time										
Coil energization - N.O.	[ms]	60...70	60...70	60...70	60...70	60...70	64...68	66...70	66...70	
Coil de-energization - N.O.	[ms]	13...17	13...17	13...17	13...17	13...17	43...47	45...49	45...49	
Coil Consumption										
Sealed AC	[VA]	16.3	16.3	21.5	35.2	35.2	14	17	29	
Inrush AC	[VA]	322	322	426	518	518	571	1000	1000	
Sealed DC	[VA]	11.0	11.0	14.3	24.2	24.2	14	17	29	
Inrush DC	[VA]	403	403	529	644	644	571	1000	1000	
Thermal Power Dissipation										
AC	[W]	3.9	3.9	3.8	3.7	3.7	4.7	4.9	5.3	
DC	[W]	2.4	2.4	2.4	2.5	2.5	5.0	6.3	7.8	

General Information

Circuit Protection

Disconnect Switches

Motor Protectors

Contactors

Overloads

Enclosed Starters

Relays

Pushbuttons and Pilot Lights

Terminal Blocks

Power Factor Correction

Appendix A

Appendix B

CWM Series - IEC Standard Contactors

Power Contacts

TYPE		CWM9	CWM12	CWM18	CWM25	CWM32	CWM40	CWM50	CWM65	CWM80	CWM95	CWM105	
Standard UL/CSA Ratings													
Rated Operating Voltage	[V]	600											
AC-1 (General Purpose)	[A]	25	25	32	32	60	60	90	110	110	140	140	
Switching Motor Loads													
Full Voltage - 50/60Hz													
1-phase	115V	[A]	9.8	13.8	16	24	34	34	56	56	80	80	100
	230V	[A]	10	12	17	28	28	28	40	50	68	68	88
	115V	[HP]	1/2	3/4	1	2	3	3	5	5	7-1/2	7-1/2	10
	230V	[HP]	1-1/2	2	3	5	5	7 1/2	10	10	15	15	20
3-phase	200V	[A]	11	11	17.5	25	32.2	32.2	48.3	62.1	62.1	78.2	92
	230V	[A]	9.6	9.6	15.2	22	28	42	42	54	68	80	104
	460V	[A]	7.6	11	14	21	27	40	52	65	65	77	96
	575V	[A]	9	11	17	17	27	27	41	52	62	77	77
	200V	[HP]	3	3	5	7-1/2	10	10	15	20	20	25	30
	230V	[HP]	3	3	5	7-1/2	10	15	15	20	25	30	40
	460V	[HP]	5	7-1/2	10	15	20	30	40	50	50	60	75
575V	[HP]	7-1/2	10	15	15	25	25	40	50	60	75	75	
Short Circuit Rating	600V [kA]	5	5	5	5	5	5	10	10	10	10	10	
Standard IEC Ratings (IEC EN 60947)													
Rated Operating Voltage	[V]	690						1000					
Rated Thermal Current I _{th}	[A]	25	25	32	45	60	60	90	110	110	140	140	
Switching Motor Loads													
AC-3 - 50/60Hz													
3-phase	220-240V	[A]	9	12	18	25	32	40	50	65	80	95	105
	380-400V	[A]	9	12	18	25	32	40	50	65	80	95	105
	415-440V	[A]	9	12	18	25	32	40	50	65	80	95	105
	500V	[A]	7.5	10.5	14	19	24	32	38	55	63	79	85
	660-690V	[A]	7	9	13	15	22	25	34	44	48	60	80
	220-240V	[kW]	2.2	3	4	7.5	9	11	15	18.5	22	25	30
	380-400V	[kW]	4	5.5	7.5	11	15	18.5	22	30	37	45	55
	415-440V	[kW]	4	5.5	7.5	11	15	22	25	37	45	50	55
	500V	[kW]	5.5	7.5	10	15	18.5	25	30	40	45	55	65
660-690V	[kW]	5.5	7.5	10	15	18.5	30	35	45	45	55	65	
Maximum Switching Rate													
AC-1	[ops/hr]	1,200	1,200	1,200	1,200	1,200	1,200	1,200	1,200	1,200	1,200	1,200	
AC-3	[ops/hr]	1,200	1,200	1,200	1,200	1,200	1,200	1,200	1,200	1,200	600	600	
no load	[ops/hr]	9,000	9,000	9,000	9,000	9,000	9,000	9,000	5,000	5,000	5,000	5,000	
AC-4													
200,000 operations; 50/60Hz	<= 690V [A]	5	7	8	12	16	18.5	23	30	37	44	50	
	220-230V [kW]	1.1	1.5	1.5	3	4	4.5	5.5	7.5	9.2	11	12.5	
	[HP]	1.5	2	2	4	5.4	6	7.5	10	12.5	15	17	
	380-400V [kW]	2.2	3	3.7	5.5	7.5	9.2	11	15	18.5	22	22	
	[HP]	3	4	5	7.5	10	12.5	15	20	25	30	30	
	415-440V [kW]	2.2	3.7	4.5	5.5	9.2	11	11	15	22	22	30	
	[HP]	3	5	6	7.5	12.5	15	15	20	30	30	40	
	500V [kW]	3	4	5.5	7.5	10	11	15	18.5	22	25	30	
	[HP]	4	5.4	7.5	10	13	15	20	25	30	33	40	
	660-690V [kW]	3	4.5	5.5	7.5	11	12.5	15	20	25	30	33	
	[HP]	4	6	7.5	10	15	17	20	27	33	40	45	

Power Contacts continued

Power Contacts cont.

Type			CWM9	CWM12	CWM18	CWM25	CWM32	CWM40	CWM50	CWM65	CWM80	CWM95	CWM105
Breaking Capacity	Ue=400V	[A]	250	250	250	450	450	920	920	920	920	1050	1050
	Ue=500V	[A]	250	250	250	320	450	920	920	920	920	1050	1050
	Ue=690V	[A]	130	130	130	170	205	780	780	780	780	950	950
Impedance per Pole		[mW]	2.41	2.41	2.35	1.65	1.28	0.95	0.85	0.86	0.86	0.76	0.76
Power Dissipation per Pole													
	AC-1	[W]	1.47	1.47	2.46	3.34	4.6	3.42	6.86	10.40	10.40	14.89	14.89
	AC-3	[W]	0.19	0.34	0.78	1.03	1.31	1.52	2.12	3.63	5.5	6.86	8.37
Short Time Current Icw													
	1 sec.	[A]	455	455	570	630	1010	1265	1580	2530	2530	3300	3300
	5 sec.	[A]	205	205	254	280	450	450	710	1130	1130	1485	1485
	10 sec.	[A]	144	144	180	200	320	400	500	800	800	1050	1050
	30 sec.	[A]	85	85	104	115	185	230	290	460	460	600	600
	1 min.	[A]	60	60	74	80	130	165	205	325	325	430	430
	3 min.	[A]	35	35	46	50	90	100	120	185	185	250	250
	Rec. time	[min.]	10	10	10	10	10	10	10	10	10	10	10
Short Circuit Coordination													
Acc. to IEC													
Coordination Type "1"	gL/gG	[A]	50	50	63	63	100	125	200	200	200	250	250
Coordination Type "2"	gL/gG	[A]	25	35	35	50	63	80	100	125	125	160	200
Acc. to UL/CSA	J Type	[A]	25	35	40	45	60	70	100	125	125	150	200

Built-in Auxiliary Contacts

TYPE		CWM9	CWM12	CWM18
Rated Insulation Voltage Ui				
Acc. IEC; VDE 0660		[V]	1000	
Acc. UL; CSA		[V]	600	
Rated Operating Voltage Ue				
Acc. IEC; VDE 0660		[V]	690	
Acc. UL; CSA		[V]	600	
Rated Thermal Current Ith <=55°C		[A]	20	
Rated Operating Current Ie				
Acc. IEC 60947-5-1 / AC-15	110-127V	[A]	10	
	220-240V	[A]	10	
	380-400V	[A]	6	
	415-450V	[A]	5	
	500V	[A]	4	
	660-690V	[A]	2	
Acc. UL; CSA			A600	
Rated Operating Current Ie				
Acc. IEC 60947-5-1 / DC-13	24V	[A]	6	
	48V	[A]	4	
	110V	[A]	2	
	220V	[A]	0.7	
	440V	[A]	0.7	
Acc. UL; CSA			P600	
Making Capacity Im				
AC-15 / AC-11	Ue <= 690V 50/60Hz	[A]	250	
DC-13 / DC-11	Ue <= 440Vdc	[A]	250	
Breaking Capacity Ic				
AC-15 / AC-11	Ue <= 400V 50/60Hz	[A]	250	
DC-13 / DC-11	Ue <=220Vdc	[A]	2	
Short Circuit Protection with Fuses				
Acc. IEC 60947-5-1 - gL/gG		[A]	10	
Minimum Switching Capacity		[V/mA]	17/5	
Electrical Endurance		Million ops.	1	
Mechanical Endurance		Million ops.	10	
Guaranteed Non-Overlap Time		[ms]	1.5	
Insulation Resistance		[MOhm]	>10	

CWM Series - IEC Standard Contactors

Power Contacts cont.

TYPE	Units		CWM112	CWM150	CWM180	CWM250	CWM300	CWM400	CWM630	CWM800
NEMA Ratings										
Rated Operating Voltage		[V]	600							
AC-1 (General Purpose)		[A]	170	170	200	300	400	450	660	900
Switching Motor Loads										
Full Voltage - 50/60Hz										
1-phase	115V	[A]	-	-	-	-	-	-	-	-
	230V	[A]	-	-	-	-	-	-	-	-
	115V	[HP]	-	-	-	-	-	-	-	-
	230V	[HP]	-	-	-	-	-	-	-	-
3-phase	200V	[A]	120	150	177	221	285	359	414	552
	230V	[A]	130	154	192	248	312	360	480	772
	460V	[A]	124	156	180	240	302	361	477	-
	575V	[A]	99	144	192	242	336	289	382	-
	200V	[HP]	40	50	60	75	100	125	150	200
	230V	[HP]	50	60	75	100	125	150	200	300
	460V	[HP]	100	125	150	200	250	300	400	600
	575V	[HP]	100	150	200	250	350	300	400	600
Short Circuit Rating	600V	[kA]	10	10	10	18	18	18	30	30
Standard IEC Ratings (IEC/EN 60947)										
Rated Operating Voltage		[V]	1000							
Rated Thermal Current I _{th}		[A]	180	225	225	350	350	450	660	900
Switching Motor Loads										
AC-3 - 50/60Hz										
3-phase	220-240V	[A]	112	150	180	250	300	400	630	800
	380-400V	[A]	112	150	180	250	300	400	630	800
	415-440V	[A]	112	150	180	250	300	400	630	800
	500V	[A]	95	130	155	220	265	350	500	720
	660-690V	[A]	82	110	135	185	220	300	420	630
	220-240V	[kW]	30	45	55	75	90	110	185	220
	380-400V	[kW]	55	75	90	132	160	220	330	450
	415-440V	[kW]	55	90	110	150	185	220	370	500
500V	[kW]	55	90	110	160	200	220	330	500	
660-690V	[kW]	75	110	110	160	200	260	400	560	
Maximum Switching Rate										
AC-1	[ops/hr]	600	600	600	600	600	500	500	500	
AC-3	[ops/hr]	600	600	600	600	600	500	500	500	
no load	[ops/hr]	1,000	1,000	1,000	1,000	1,000	1,000	1,000	1,000	

Power Contact cont.

TYPE			CWM112	CWM150	CWM180	CWM250	CWM300	CWM400	CWM500	CWM630	CWM800
AC-4	Voltage	Units									
200,000 operations; 50/60Hz	<= 690V	[A]	50	55	58	100	130	-	-	-	-
	220-230V	[kW]	18.5	20	22	37	45	90	-	110	185
		[HP]	25	27	30	50	60	125	-	150	250
	380-400V	[kW]	30	33	37	55	75	150	-	220	330
		[HP]	40	44	50	75	100	200	-	300	450
	415-440V	[kW]	37	40	45	63	80	185	-	220	370
		[HP]	50	54	60	84	107	250	-	300	500
	500V	[kW]	40	45	50	75	90	-	-	-	-
		[HP]	54	60	67	100	121	-	-	-	-
660-690V	[kW]	45	50	55	90	100	-	-	-	-	
	[HP]	600	67	75	121	133	-	-	-	-	
Maximum Switching Rate	[ops/hr]	150	150	150	150	150	-	-	-	-	
Making Capacity		[A]	1430	1820	2100	2600	3000	-	-	-	-
Breaking Capacity											
	Ue<=400V	[A]	1290	1350	1400	2000	-	4000	-	6300	8000
	Ue=500V	[A]	1290	1350	1400	2000	-	4000	-	6300	8000
Impedance per pole		[mW]	0.5	0.5	0.45	0.3	0.3	-	-	-	-
Power Dissipation per Pole											
	AC-1	[W]	16	25	21.6	35	45.7	-	-	-	-
	AC-3	[W]	6.2	11.1	13.8	17.9	25.7	-	-	-	-
Short Time Current Icw											
0° ≤ 104°F	1 sec.	[A]	3165	3763	4649	4427	-	-	-	-	-
	5 sec.	[A]	1820	2164	2673	2546	-	-	-	-	-
	10 sec.	[A]	1430	1700	2100	2000	-	-	-	-	-
	30 sec.	[A]	826	980	1212	1155	-	-	-	-	-
	1 min.	[A]	584	694	857	816	-	-	-	-	-
	3 min.	[A]	337	401	495	471	-	-	-	-	-
	Recovery time	[min.]	10	10	10	10	10	-	-	-	-
Short Circuit Coordination											
Acc. to IEC											
Coordination type "1"	gL/gG	[A]	315	355	355	500	630	630	-	800	1000
Coordination type "2"	gL/gG	[A]	224	250	250	400	500	-	-	-	-
Acc. to UL/CSA	J Type	[A]	250	350	400	500	700	700	-	900	1100

- General Information
- Circuit Protection
- Disconnect Switches
- Motor Protectors
- Contactors
- Overloads
- Enclosed Starters
- Relays
- Pushbuttons and Pilot Lights
- Terminal Blocks
- Power Factor Correction
- Appendix A
- Appendix B

CWM Series - IEC Standard Contactors

General Ratings

TYPE	CWM9	CWM12	CWM18	CWM25	CWM32	CWM40	CWM50	CWM65	CWM80	CWM95	CWM105		
Standards	Units: Devices according to International Standards IEC 60947-1 / 60947-4-1, European Standards EN 60947-1 / 60947-4-1, Underwriters Laboratories - UL 508; CSA C.22.2/14; VDE 0660/102												
Rated Insulation Voltage Ui													
Acc. IEC; VDE 0660	[V]	1000											
Acc. UL; CSA	[V]	600											
Rated Impulse Voltage Uimp													
Acc. IEC60947-1	[kV]	6								8			
Rated Operating Frequency	[Hz]	25...400											
Degree of Protection													
Main terminals		IP20					Protection against direct contact Acc. VDE 0160 - Part. 100						
Coil terminals							IP10						
Auxiliary terminals													
Ambient Temperature													
Storage		-55 to +80oC (-67 to +176oF)											
Operating		-25 to +55oC (-13 to +131oF)											
Altitude													
Up to 1,500m		Nominal values											
		See graphic on page 194											
Pollution Degree		3											
Climatic Withstand		According to IEC 60680-2											
Mounting		35mm rail Acc. DIN EN 50 022											
Vibration Resistance (5 to 200 Hz)													
Contactors open	[g]	3	3	3	7.5	8	8	4.5	4.5	4.5	5	5	
Contactors closed at Uc	[g]	6	6	6	8	12	12	9	9	9	7	7	
Mechanical Endurance													
AC Coil	Million ops.	10											
Electrical Endurance AC-3	Million ops.	1.8	1.6	1.2	1.2	1.2	1.2	1.1	1.1	1.1	1.1	1.1	
Shock Resistance (1/2 sin wave = 11ms)													
Contactors open	[g]	8	8	8	8	7	7	6	6	6	6	6	
Contactors closed at Uc	[g]	12	12	12	12	12	12	10	10	10	10	10	
Weight	[kg]	0.30	0.30	0.30	0.30	0.52	0.54	1.11	1.12	1.13	1.45	1.47	
AC Coil	[lb]	0.65	0.65	0.65	0.65	1.15	1.19	2.44	2.47	2.49	3.20	3.24	
Terminal Capacity													
Cross/Slotted Combination													
Allen Head													
Fine - Stranded with sleeve	Top [mm2]												
	Bottom [mm2]	2x0.5-2.5	2x0.5-2.5	2x0.5-2.5	2x1-2.5	0.75-16	0.75-16	1-35	1-35	1-35	1.5-50	1.5-50	
Coarse - Stranded / Solid	Top [mm2]	2x1-2.5	2x1-2.5	2x1-2.5	2x1-2.5	1-16	1-16	1.5-35	1.5-35	1.5-35	2.5-50	2.5-50	
	Bottom [mm2]	or 2x2.5-6	or 2x2.5-6	or 2x2.5-6	or 2x2.5-10	1.5-16	1.5-16	6-35	6-35	6-35	6-35	6-35	
Stranded / Solid (UL / CSA)	Top [AWG]	2x20-12	2x20-12	2x20-12	2x18-12	18-6	18-6	16-2	16-2	16-2	16-1	16-1	
	Bottom [AWG]	or 2x12-10	or 2x12-10	or 2x12-10	or 2x12-8	16-6	16-6	14-2	14-2	14-2	10-2	10-2	
Drive Size		Screwdriver - Philips #2					5/32" (4mm.)						
Tightening Torque	lb-in (Nm)	8.9...15 (1...1.7)	8.9...15 (1...1.7)	8.9...15 (1...1.7)	14.2...26.6 (1.6...3)	22.1...35.4 (2.5...4)	22.1...35.4 (2.5...4)	35.4...53.1 (4...6)	35.4...53.1 (4...6)	35.4...53.1 (4...6)	44.3...57.5 (5...6.5)	44.3...57.5 (5...6.5)	

General Ratings

TYPE	CWM112	CWM150	CWM180	CWM250	CWM300	CWM400	CWM630	CWM800		
Standards Units	Devices according to International Standards IEC 60947-1 / 60947-4-1, European Standards EN 60947-1 / 60947-4-1, Underwriters Laboratories - UL 508; CSA C.22.2/14; VDE 0660/102									
Rated Insulation Voltage Ui										
Acc. IEC; VDE 0660	[V]	1000								
Acc. UL; CSA	[V]	600								
Rated Impulse Voltage Uimp										
Acc. IEC60947-1	[kV]	8								
Rated Operating Frequency	[Hz]	25...400								
Degree of protection		Protection against direct contact acc. VDE 0160 - Part. 100								
Main terminals		IP00								
Coil terminals		IP20								
Auxiliary terminals		IP20								
Ambient Temperature										
Storage		-55 to +80°C (-67 to +176°F)								
Operating		-25 to +55°C (-13 to +131°F)								
Altitude										
Up to 1,500m		Nominal values								
Other altitudes		See graphic on page 194					up to 2000m			
Pollution Degree		3								
Climatic withstand		According to IEC 68-2								
Mounting		Screw to panel								
Vibration Resistance (5 to 200 Hz)										
Contactors open	[g]	4								
Contactors closed at Uc	[g]	4								
Mechanical Endurance										
AC Coil	Million ops.	10					5			
Electrical Endurance AC-3	Million ops.	1.1	1.1	1.0	1.0	1.0	0.5			
Shock Resistance (1/2 sin wave = 11ms)										
Contactors open	[g]	3								
Contactors closed at Uc	[g]	3								
Weight										
AC/DC Coil	[kg]	2.54	2.54	4.04	6.14	6.14	9.2	22.4	22.4	
	[lb]	5.60	5.60	8.91	13.54	13.54	20	49	49	
Terminal Capacity										
Fine - Stranded with sleeve	[mm ²]	2 x (25-70)		2 x (50-120)		2 x (50-150)		1 x 150	1 x 240	1 x 240
AWG wires with end sleeve		1 x 300 or 2 x 107			1 x 500 or 2 x 300		Nº2 30x5	Nº2 50x5	Nº2 60x5	
Busbars	[mm]	2 x (15 x 3)		2 x (20 x 3)		2 x (30 x 5)		-	-	-
Tightening Torque	lb-in (Nm)	47.8-53.1(5.4-6)		123.9-141.6(14-16)		203.6-230.1(23-26)		203.6(23)	504.5(57)	504.5(57)

Contactors

CWM Series - IEC Standard Contactors Auxiliary contact block ratings

TYPE	BCXMF	BCXML	BCXMRL	BLIM.02
Rated Insulation Voltage Ui				
Acc. IEC; VDE 0660	[V]			1000
Acc. UL; CSA	[V]			600
Rated Operating Voltage Ue				
Acc. IEC; VDE 0660	[V]			690
Acc. UL; CSA	[V]			600
Rated Thermal Current Ith <=55°C	[A]			10
Rated Operating Current Ie				
Acc. IEC 60947-5-1 / AC-15	110-127V	[A]		6
	220-240V	[A]		6
	380-400V	[A]		4
	415-450V	[A]		3.5
	500V	[A]		2.5
	660-690V	[A]		1.5
Acc. UL; CSA				A600
Rated Operating Current Ie				
Acc. IEC 60947-5-1 / DC-13	24V	[A]		4
	48V	[A]		2
	110V	[A]		0.7
	220V	[A]		0.3
	440V	[A]		0.15
Acc. UL; CSA				Q600
Making Capacity Im				
AC-15 / AC-11	Ue <= 400V 50/60Hz	[A]		90
DC-13 / DC-11	Ue <= 220Vdc	[A]		90
Breaking Capacity Ic				
AC-15 / AC-11	Ue <= 400V 50/60Hz	[A]		60
DC-13 / DC-11	Ue <= 220Vdc	[A]		0.95
Short Circuit Protection with Fuses				
Acc. IEC 60947-5-1 - gL/gG		[A]		10
Minimum Switching Capacity		[V/mA]		17/5
Electrical Endurance		Million ops.		1
Mechanical Endurance		Million ops.		10
Guaranteed Non-Overlap Time		[ms]		1.5
Insulation Resistance		[MΩ]		>10

Graphic Altitude

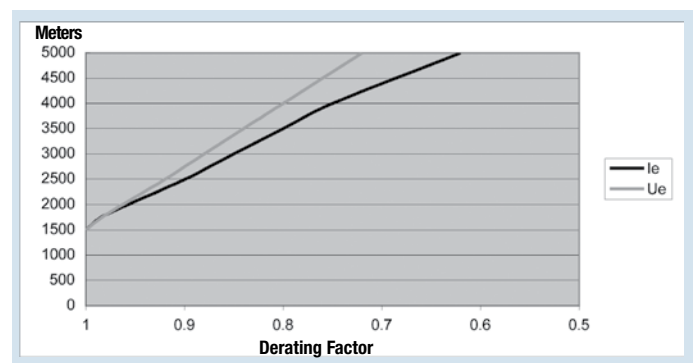

NOTE:

Altitude compensation in CWM Series contactors, considers a factor according to which the rated power must be reduced.

The derating of the permissible operating power for installation altitudes above 1,500 m (5,000 ft) is calculated according to:

$$\text{Total derating} = \text{Derating}_{\text{current}} \times \text{Derating}_{\text{voltage}}$$

Example: Altitude: 3,000 m (10,000 ft):

Derating current K1 = 0.85

Derating voltage K2 = 0.88

$$\text{Total derating} = 0.85 \times 0.88 = 0.75 \times \text{HP}$$

Mechanical Drawings mm (in)

CWM9, CWM9N, CWM12, CWM18, and CWM18N

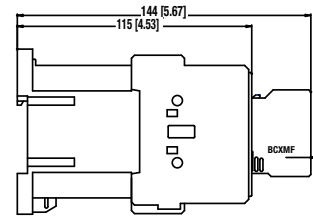
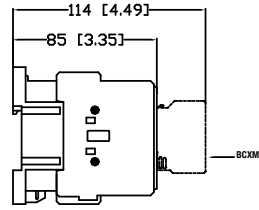
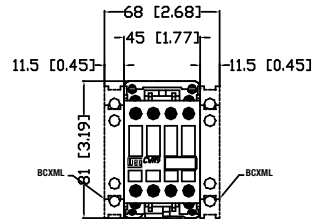
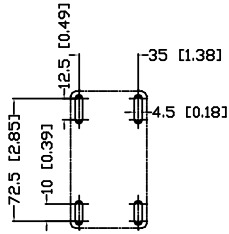

Vac Contactors

Vdc Contactors

CWM25

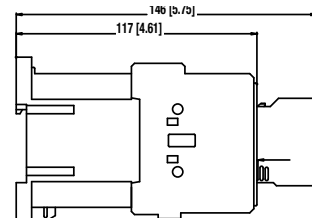
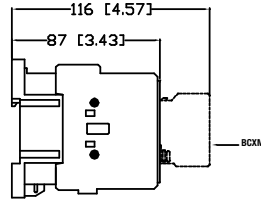
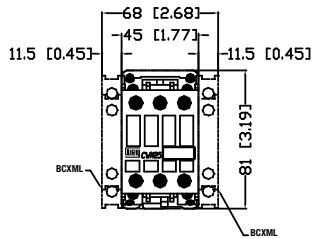
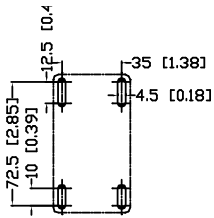

Vac Contactors

Vdc Contactors

CWM32, CWM32N and CWM40

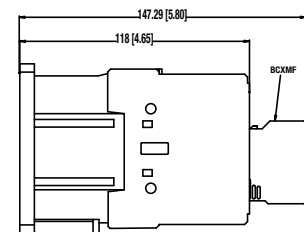
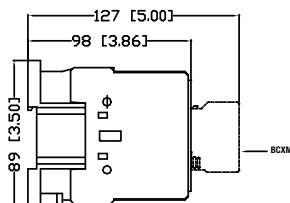
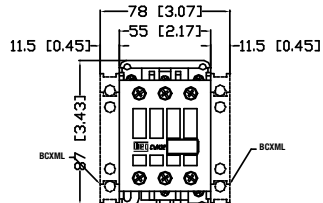
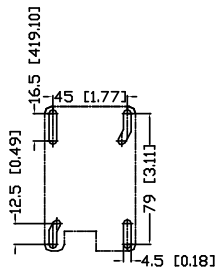

Vac Contactors

Vdc Contactors

Contactors

CWM-N Series - NEMA Rated Standard Contactor

Mechanical Drawings mm (in)

CWM50, CWM50N, CWM65 and CWM80

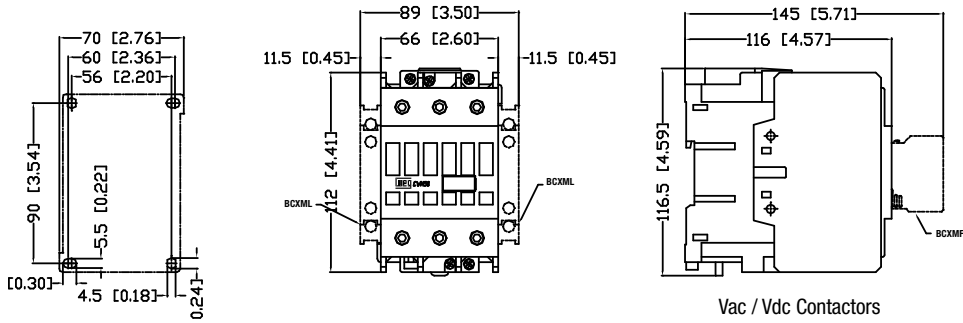

CWM95, CWM95N, and CWM105

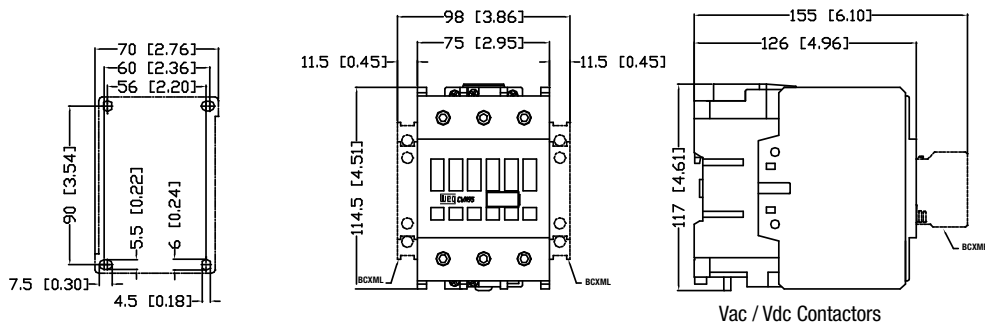

General Information

Circuit Protection

Disconnect Switches

Motor Protectors

Contactors

Overloads

Enclosed Starters

Relays

Pushbuttons and Pilot Lights

Terminal Blocks

Power Factor Correction

Appendix A

Appendix B

Mechanical Drawings mm (in)

CWM112, CWM150 and CWM150N

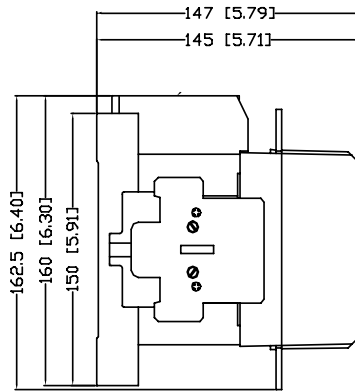
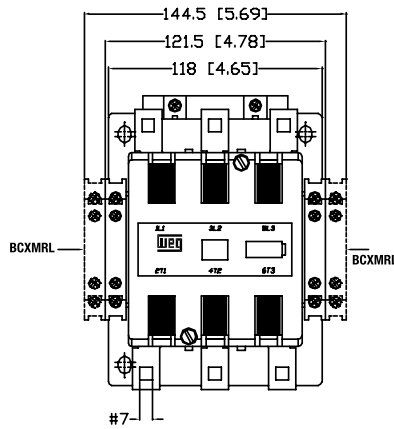
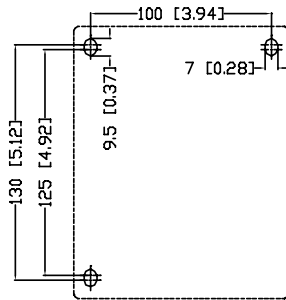

CWM180

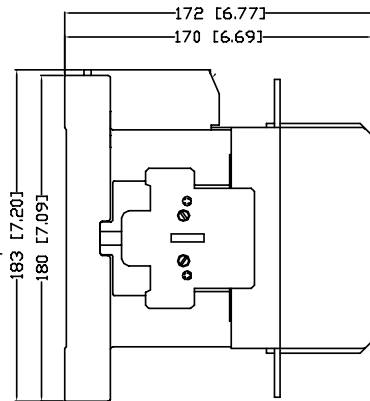
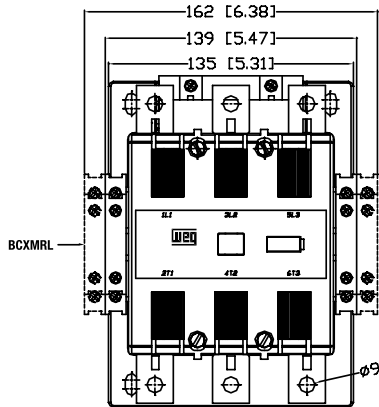
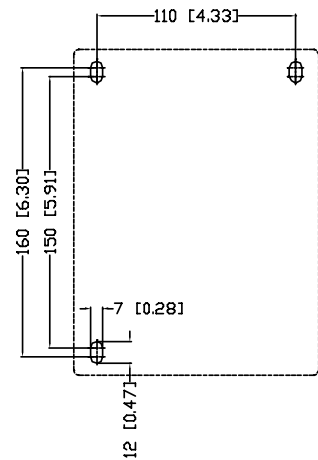

CWM250, CWM300 and CWM300N

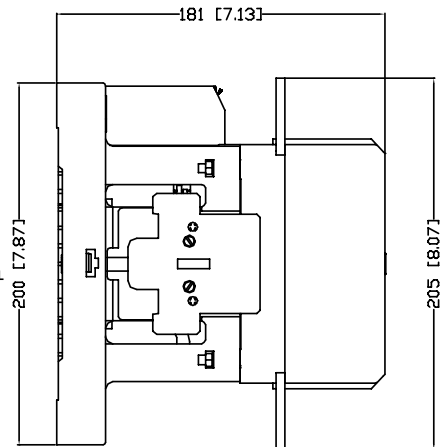
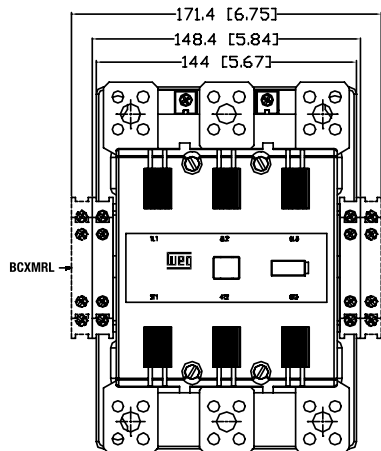
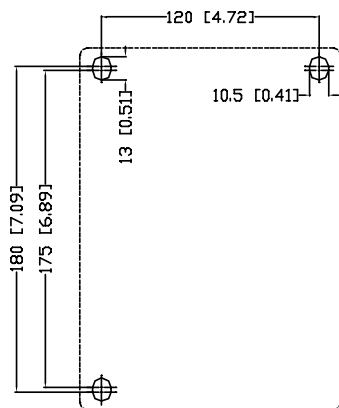

General Information

Circuit Protection

Disconnect Switches

Motor Protectors

Contactors

Overloads

Enclosed Starters

Relays

Pushbuttons and Pilot Lights

Terminal Blocks

Power Factor Correction

Appendix A

Appendix B

CWM Series - IEC Standard Contactors

Mechanical Drawings mm (in)

CWM400

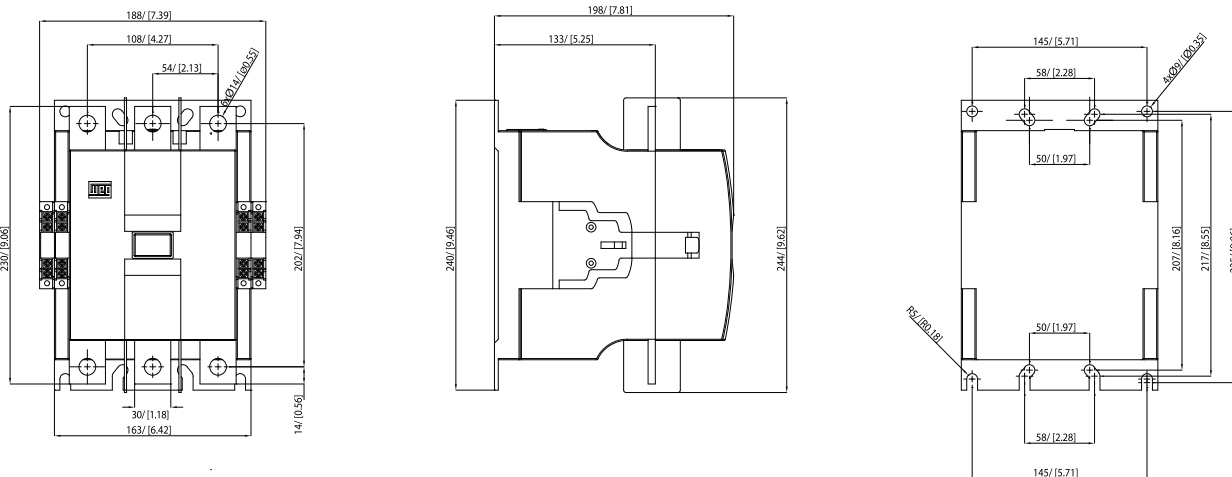

CWM630 and CWM800

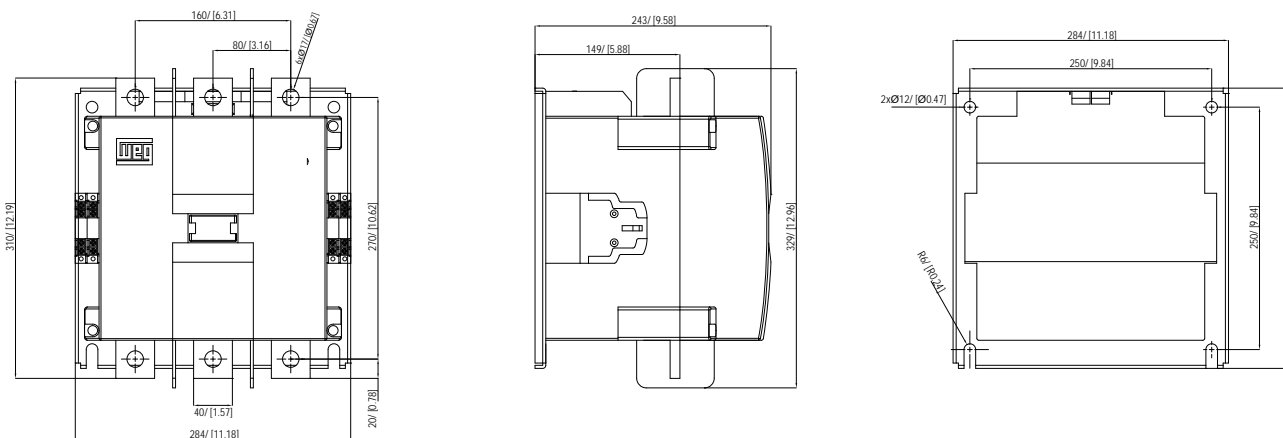

Mechanical Drawings mm (in)

CWM112 - CWM150 + LW1-S300 (contactor with lugs)

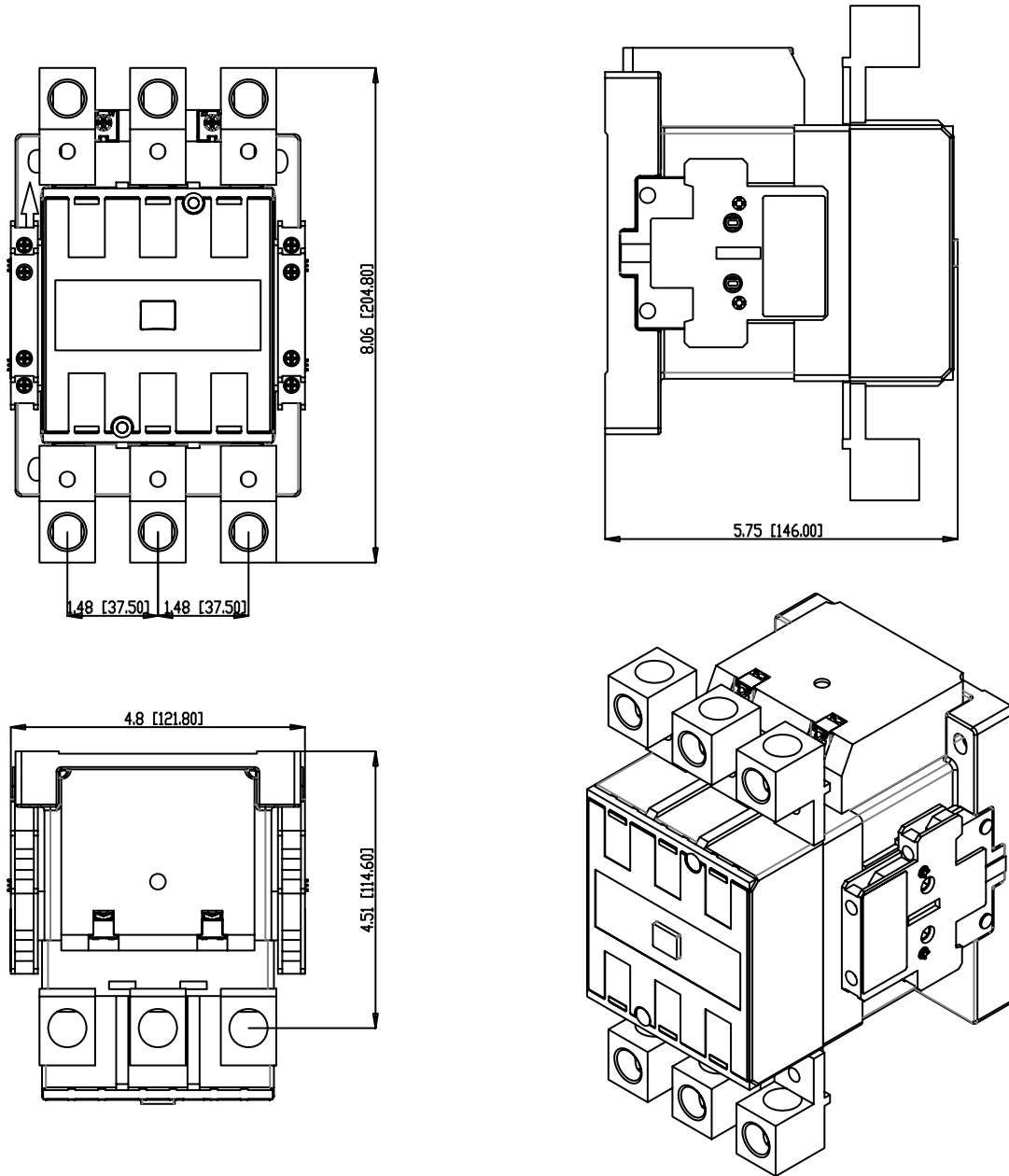

General Information

Circuit Protection

Disconnect Switches

Motor Protectors

Contactors

Overloads

Enclosed Starters

Relays

Pushbuttons and Pilot Lights

Terminal Blocks

Power Factor Correction

Appendix A

Appendix B

CWM Series - IEC Standard Contactors

Mechanical Drawings mm (in)

CWM180 + LW2-S300 (contactor with lugs)

General Information

Circuit Protection

Disconnect Switches

Motor Protectors

Contactors

Overloads

Enclosed Starters

Relays

Pushbuttons and Pilot Lights

Terminal Blocks

Power Factor Correction

Appendix A

Appendix B

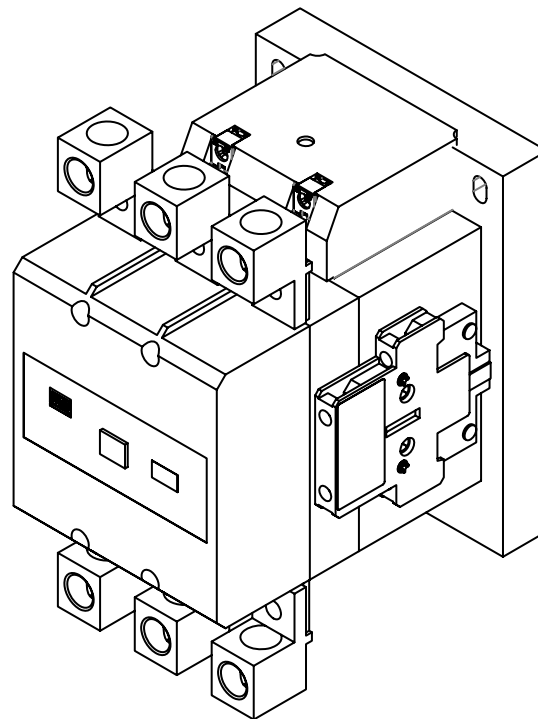
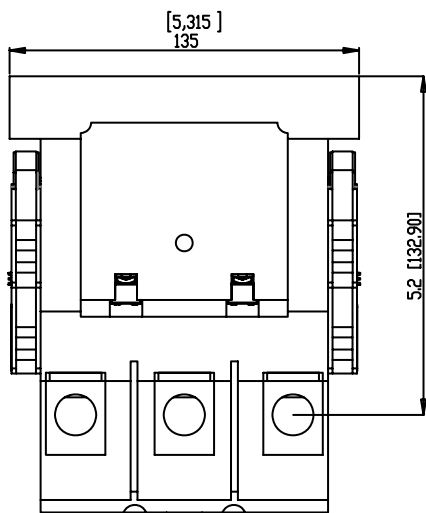
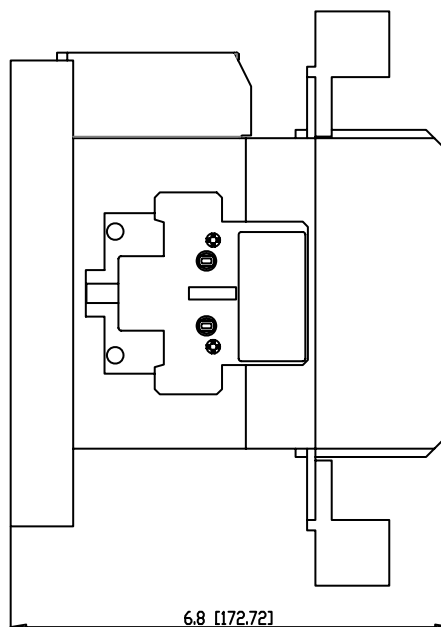
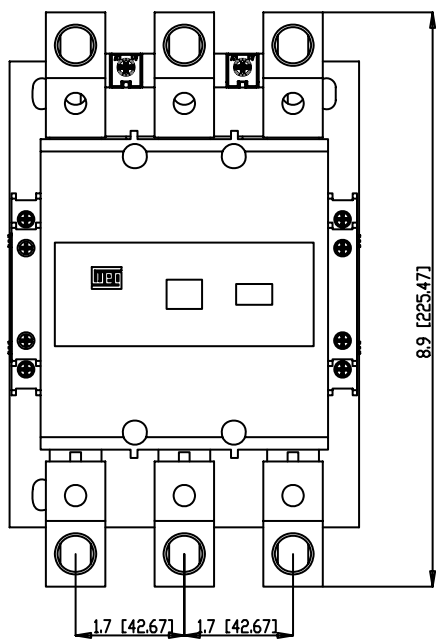

Mechanical Drawings mm (in)

CWM250 + LW1-S600 (contactor with lugs)

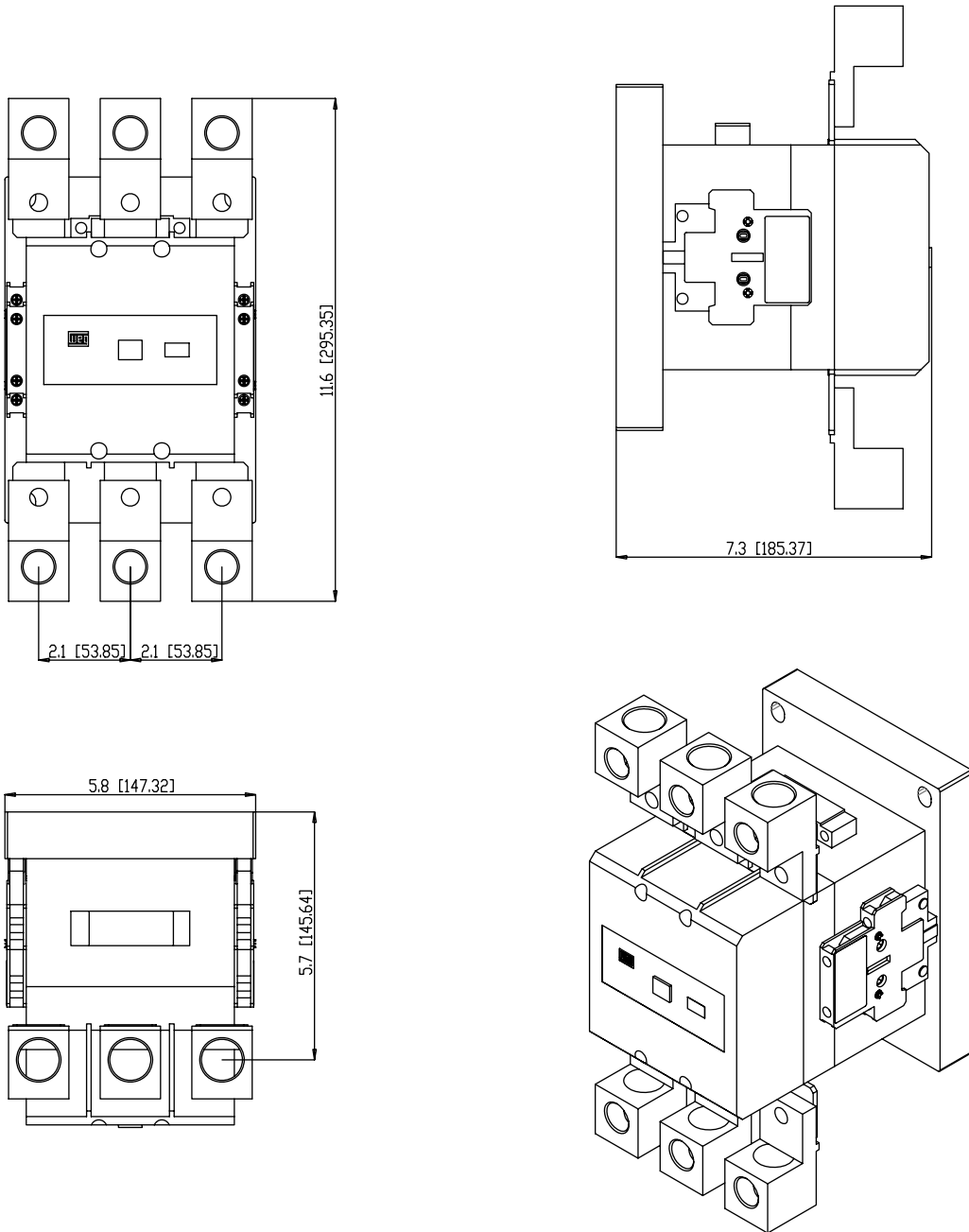

General Information

Circuit Protection

Disconnect Switches

Motor Protectors

Contactors

Overloads

Enclosed Starters

Relays

Pushbuttons and Pilot Lights

Terminal Blocks

Power Factor Correction

Appendix A

Appendix B

CWM Series - IEC Standard Contactors

Mechanical Drawings mm (in)

CWM400 + BMJ (contactor with lugs)

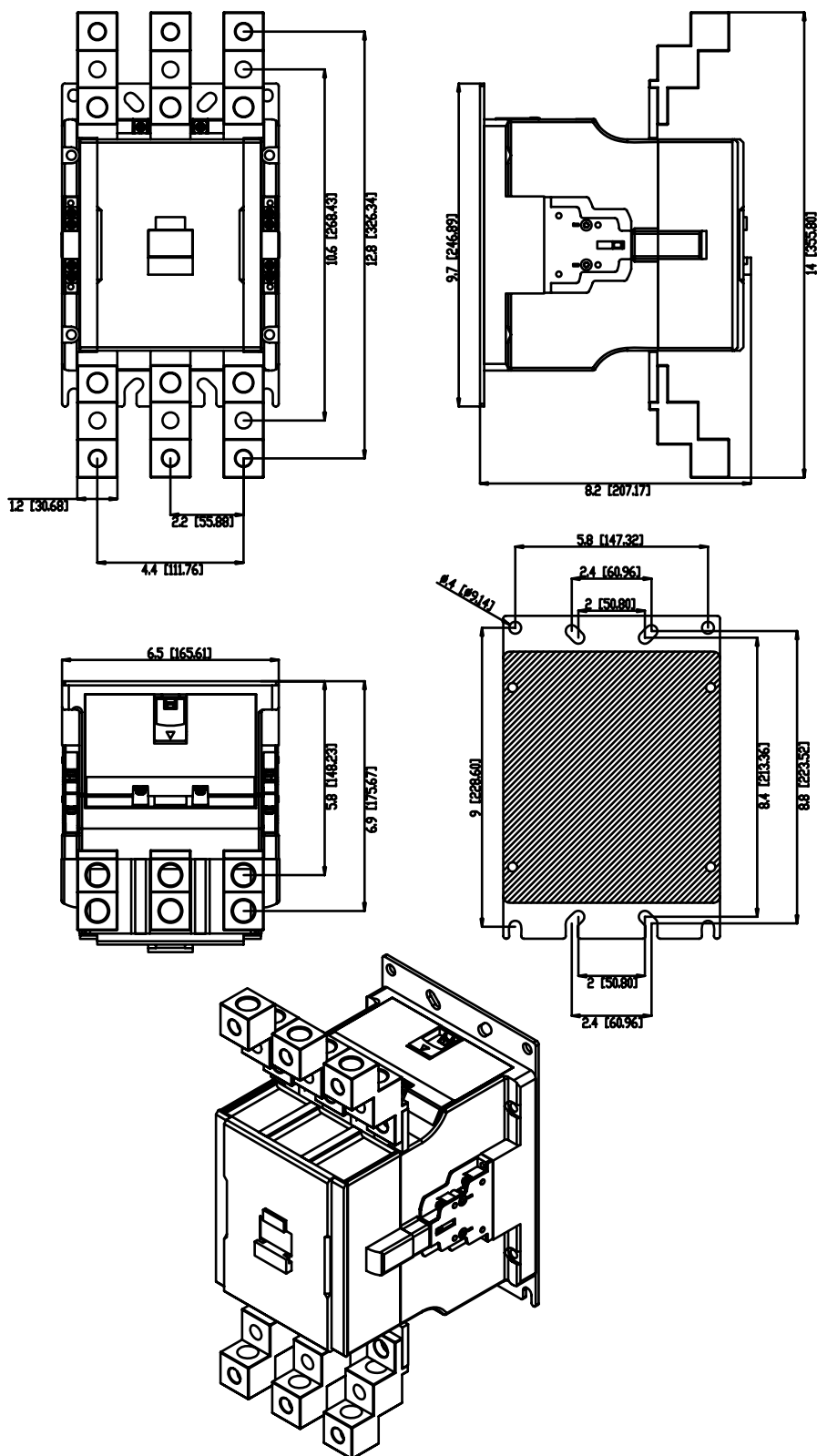

Mechanical Drawings mm (in)

CWM630-CWM800 + BMJ (contactor with lugs)

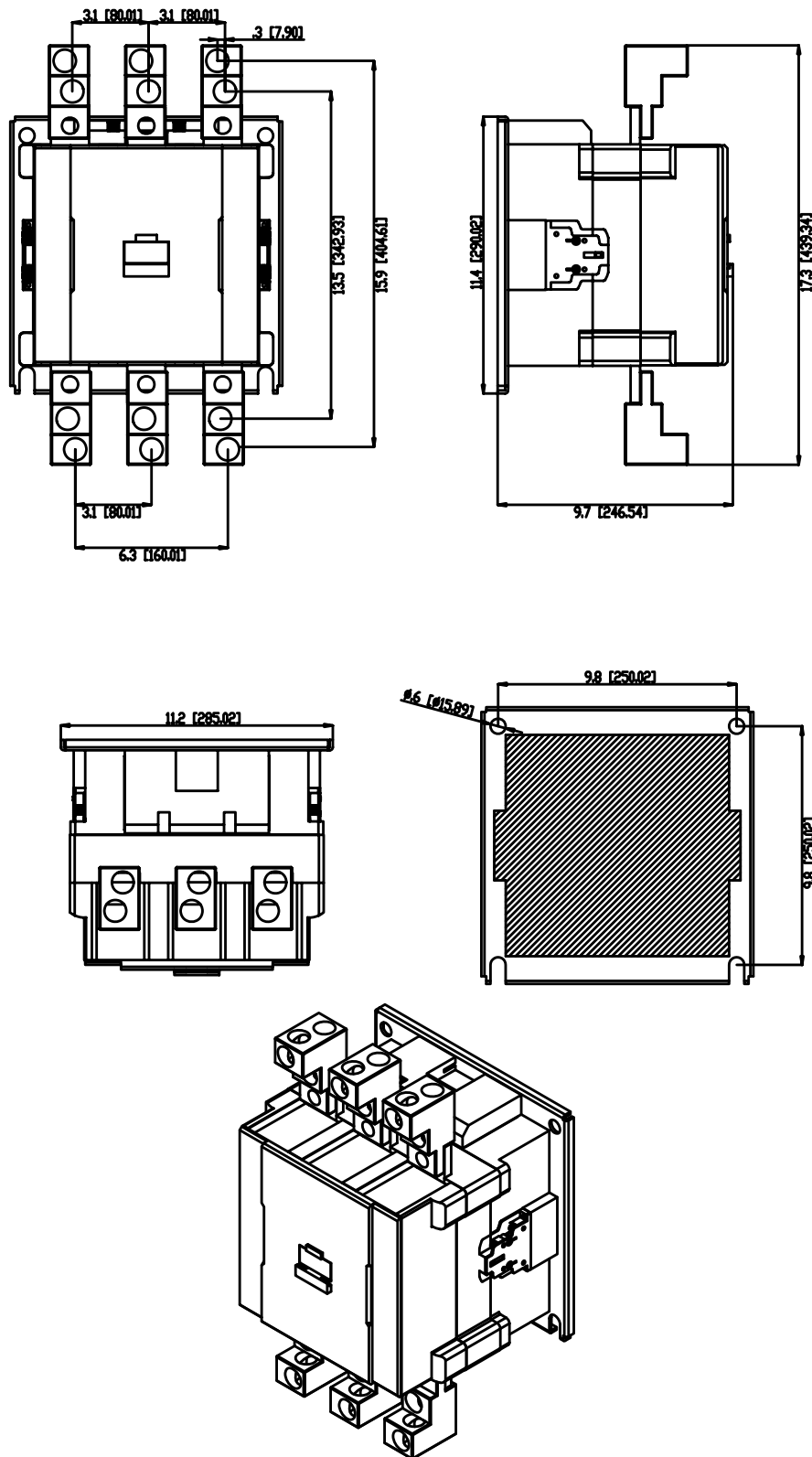

General Information

Circuit Protection

Disconnect Switches

Motor Protectors

Contactors

Overloads

Enclosed Starters

Relays

Pushbuttons and Pilot Lights

Terminal Blocks

Power Factor Correction

Appendix A

Appendix B

Contactors

CWM Series - IEC Standard Contactors

Reversing Contactors mm (in)

BLIM9-105

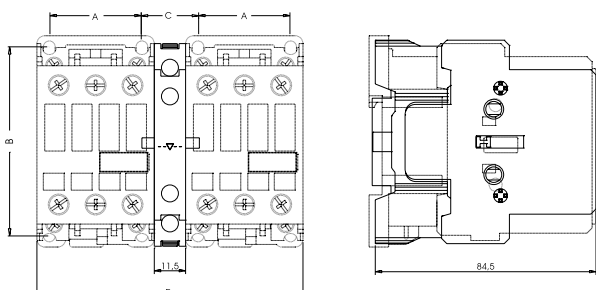

Models	A	B	C	D
CWM9...25	35 (1,4)	72,5 (2,9)	22 (0,9)	102 (4)
CWM32...40	45 (1,8)	79 (3,1)	22 (0,9)	122 (4,8)
CWM50...80	57 (2,2)	90 (3,5)	21 (0,8)	144 (5,7)
CWM95...105	57 (2,2)	90 (3,5)	29,8 (1,2)	153 (6)

BLIM112-300

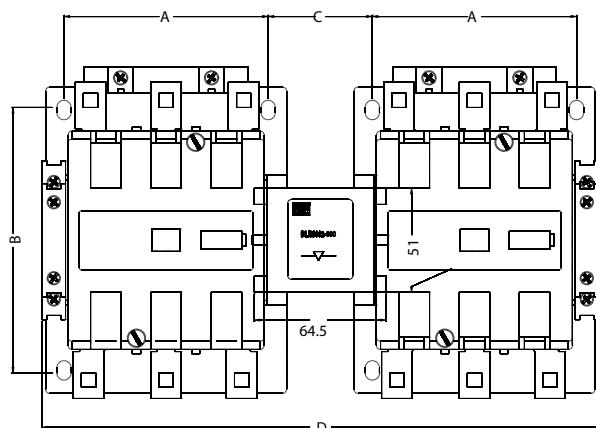

Models	A	B	C	D
CWM112...150	100 (3,9)	130 (5,1)	51 (2)	272,5 (10,7)
CWM180	110 (4,3)	160 (6,3)	58,5 (2,3)	303,5 (11,9)
CWM250...300	120 (4,7)	180 (7,1)	57 (2,2)	325,4 (12,8)

BLIM CWM400

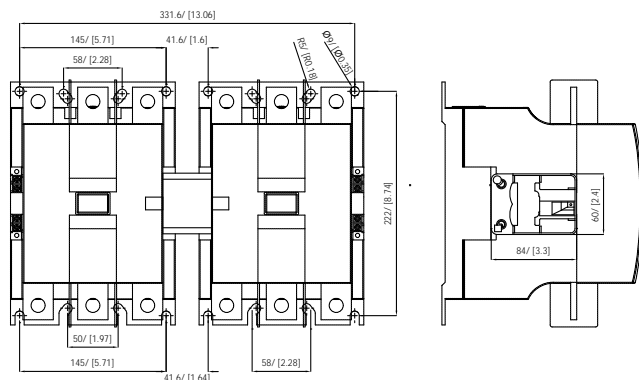

BLIM CWM800

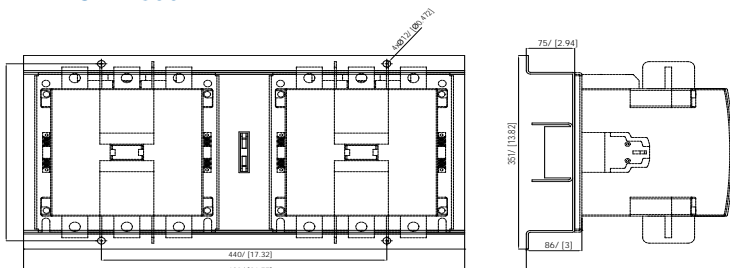

General Information

Circuit Protection

Disconnect Switches

Motor Protectors

Contactors

Overloads

Enclosed Starters

Relays

Pushbuttons and Pilot Lights

Terminal Blocks

Power Factor Correction

Appendix A

Appendix B

Mounting position¹

CWM9...105

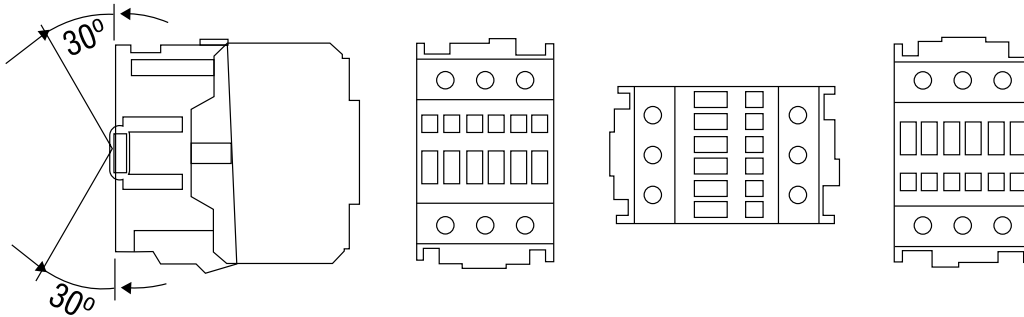

CWM112...300

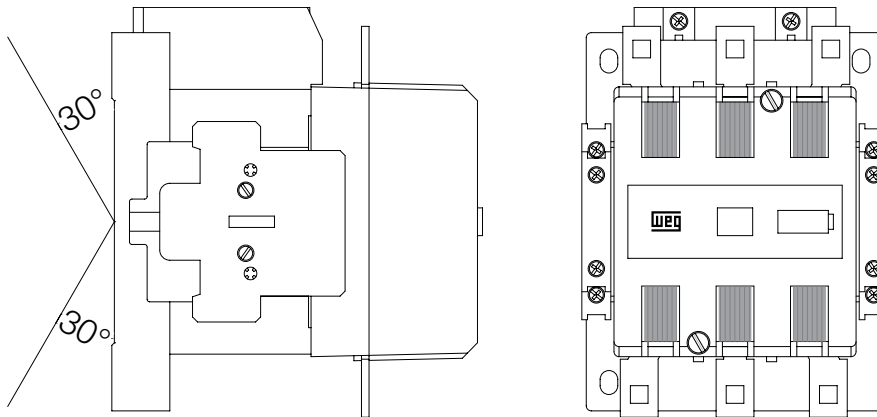

CWM400...800

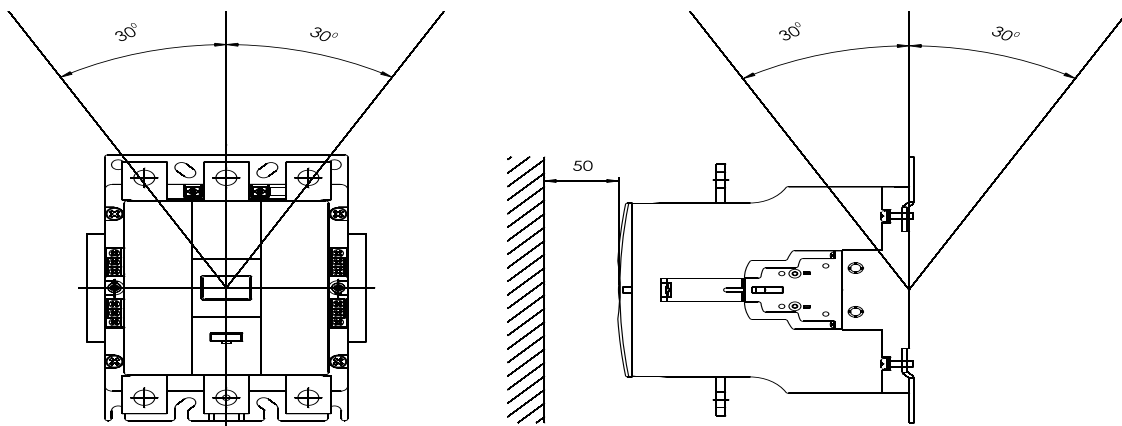

Note: 1) Consult WEG if application requires a different mounting position

General Information

Circuit Protection

Disconnect Switches

Motor Protectors

Contactors

Overloads

Enclosed Starters

Relays

Pushbuttons and Pilot Lights

Terminal Blocks

Power Factor Correction

Appendix A

Appendix B

Contactors

Contactors for Capacitor Switching

General Information

Circuit Protection

Disconnect Switches

Motor Protectors

Contactors

Overloads

Enclosed Starters

Relays

Pushbuttons and Pilot Lights

Terminal Blocks

Power Factor Correction

Appendix A
Appendix B

Contactors – Dimensions (in)

CWMC25

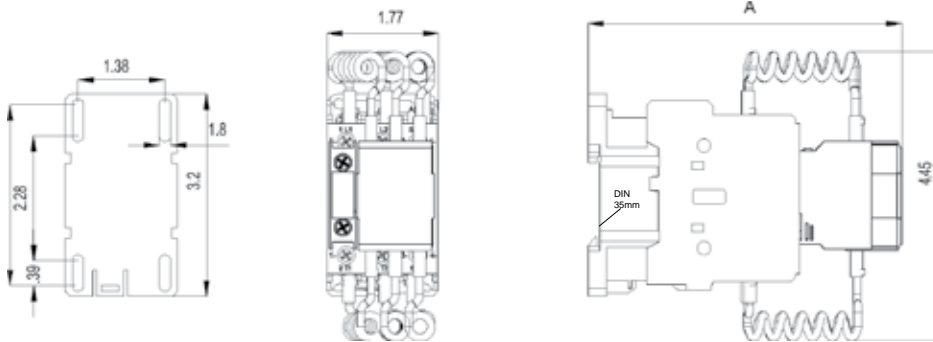

Coil	
AC	DC
A = 5.08	A = 6.26

CWMC32

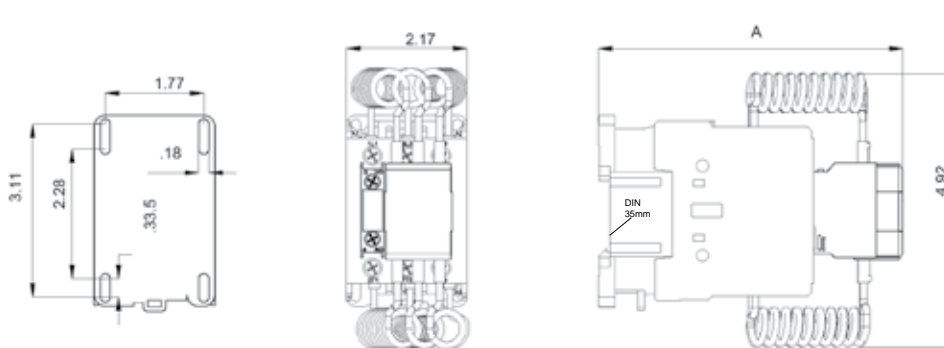

Coil	
AC	DC
A = 5.5	A = 6.3

CWMC50 and CWMC65

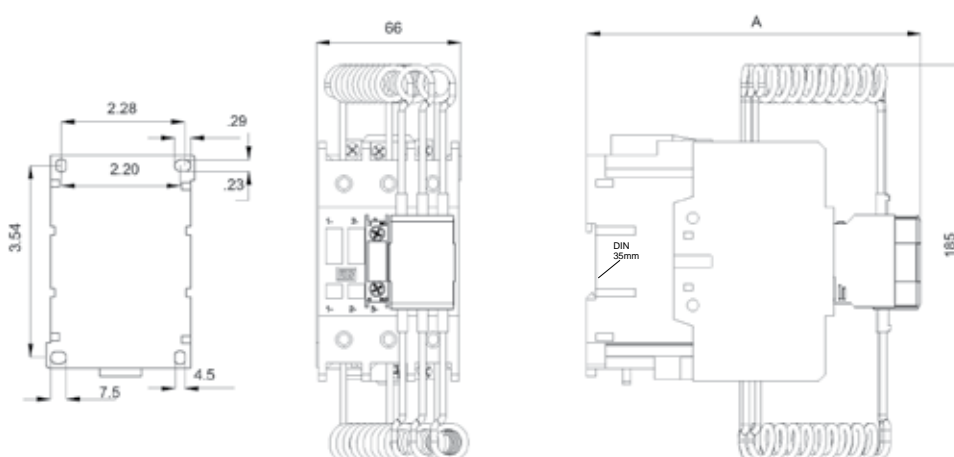

Coil	
AC	DC
A = 6.22	A = 6.22