

Low Voltage Industrial Controls

CWB and RW27-2D

IEC Contactors and Thermal Overload Relays

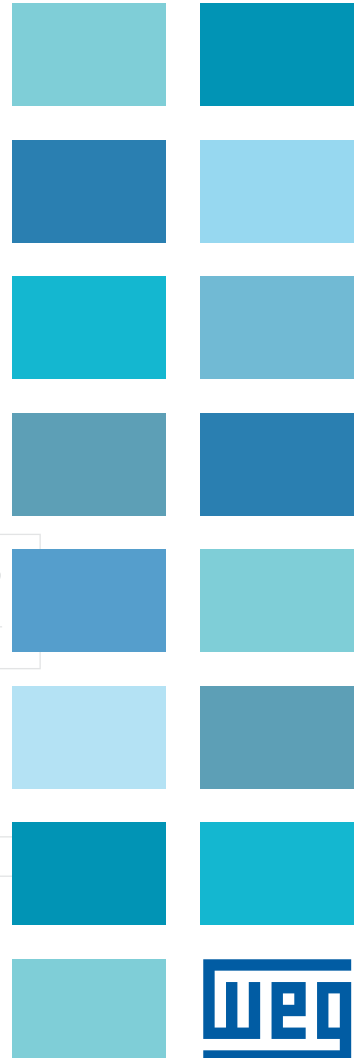

Contactors

CWB

CWB Features	A-4
Catalog Number Format	A-7
Accessories Overview	A-8
Part Number List and Pricing	A-9
Accessories and Spare Parts	A-10
Technical Data	A-13
Dimensions	A-21



CWB Features

Contactors

The traditional methods of starting electric motors such as DOL (reversing/non-reversing), and Wye-Delta remain among the safest and most cost effective solutions to provide control of and protection for low voltage electric motors. Up to at least 75Hp(55kW), contactors are the most widely accepted and used starting methods, worldwide.

Low Consumption Coils

The new CWB contactors, currently up to 38A, were designed with low consumption coils as the standard that allow for safe and reliable operation with minimum energy consumption (up to 6W/DC, up to 7.5VA/AC). The efficiency of the CWB coils also result in a reduction of the demand put on control power transformers; allowing the option to use smaller vA transformer capacities.

DC Coils with no Inrush Pick-Up Current

DC coils allow direct control of CWB contactors via PLC or digital outputs of devices such as VFDs or Soft-Starters without the need of interposing relays.

Eco Friendly

The CWB line uses only nontoxic and eco-friendly materials that are safe and sustainable.

Certifications

Developed according to

- UL 508
- IEC 60947 international standards

The new WEG CWB line of contactors meets the requirements of a wide range of industrial applications world wide.



Compact Solution

Because they are compact, 45 mm wide and available in up to 38 A (18.5 kW @ 380 / 415 V AC-3 and 25 HP @ 480 V UL 3-ph), CWB contactors lead to an overall reduction in size of control panels if compared to traditional solutions of contactors with the same ratings.

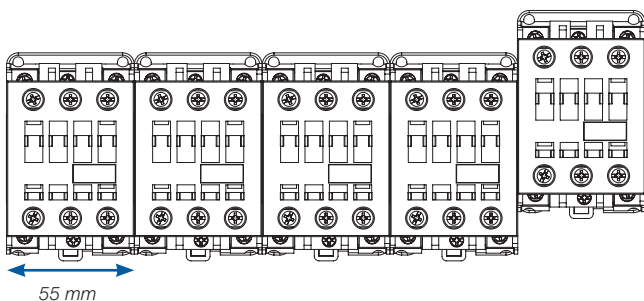
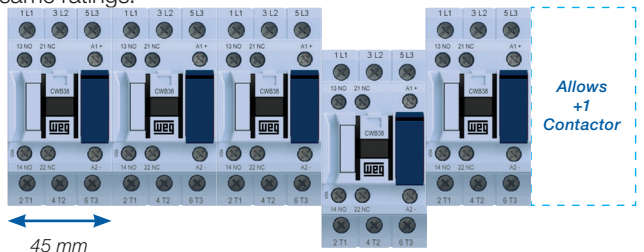

Built-In Auxiliary Contacts 1NO + 1NC

The configuration of two built-in auxiliary contacts (1NO + 1NC) makes the application of CWB contactors more flexible in most automation systems, contributing to the optimization of space within your panel.

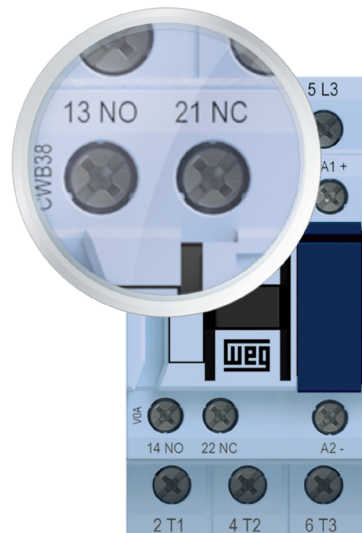

“Zero-Width” Mechanical Interlock

For applications which require mechanical interlock between contactors, WEG has developed a new mechanical system that ensures compact and easy mounting without the need of any tools. WEG’s new mechanical interlock system allows the mechanical interlock between two contactors of the CWB line with “zero” additional side space and it is possible to assemble 90 mm wide reversing starters of up to 38 A.



Simple and Compact Mounting of Surge Suppressor Blocks

The coils of CWB contactors operate smoothly with almost no disturbance in the control circuits. However, in order to reduce voltage surges due to the coil switching even further, WEG has developed surge suppressor blocks especially for the CWB line of contactors, which ensure the limitation or even complete elimination the undesired interferences. Surge suppressor blocks are easily mounted on CWB contactors without the need of any tools and without increasing volume.

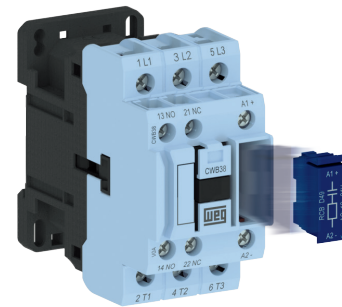

Contactor Coil Operated on AC or DC

Wide range of voltages available in only two coil versions (one for AC and another for DC) to fit the whole range of contactors from 9 to 38 A. Easy AC coil replacement and visual coil voltage indication.



Contactor with AC coil

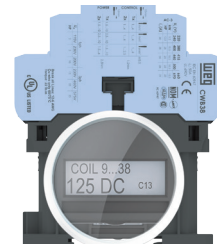

Contactor with DC coil

Simple and Organized Control Circuits

In order to optimize space in electric panels even more, the WEG CWB contactor line has a front channel for the passage of control cables. This could reduce or eliminate the need of control cable passage through the side or front part of contactors providing a “cleaner” and more organized assembly of the control circuit.

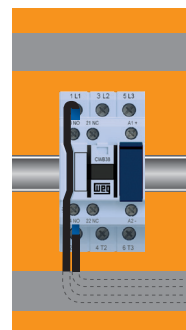

CWB Line

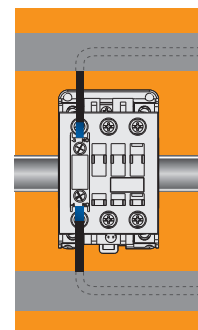

Standard Contactors

Easy Access Power and Control Terminals

All power terminals, auxiliary contacts and coils are designed to provide users with fast front access, facilitating installation, measurements and interventions for preventive and corrective maintenance of starters.

Additional Contact Blocks

Besides the 1NO + 1NC built-in auxiliary contacts, in order to meet the most complex control needs, WEG has also developed auxiliary high performance contact blocks which can be easily mounted on the front or side of CWB contactors, allowing the combination of up to six auxiliary contacts per contactor up to 38 A.

An important characteristic of the side auxiliary contact blocks of the CWB line is the small dimension (only 9 mm wide) which meets the requirements of modularity, allowing more compact combinations of motor starters with motor protective circuit breakers when easy-connection busbars are used.

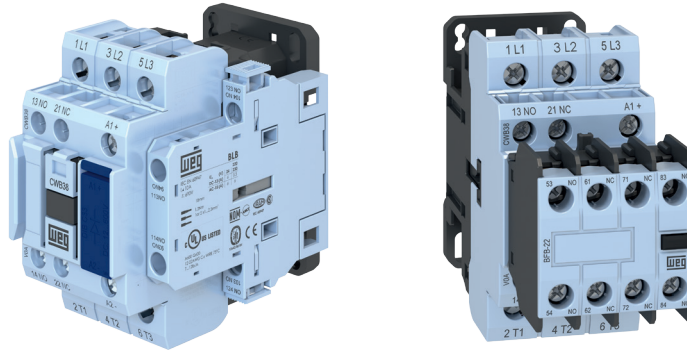

Safety Against Accidental Contact

All power and control terminals of CWB contactors have IP20 degree of protection, increasing safety against accidental frontal contact.

Safety-Related Applications

In automation systems of machines and equipment, it is common to use special contactors in combination with specific safety relays. The new WEG CWB contactors allow this combination due to the arrangement of the contacts which meets IEC 60947-4-1 Annex F (Mirror Contact) and IEC 60947-5-1 Annex L (Mechanically Linked Contact) requirements.



IEC 60947-5-1
Mechanically linked
contacts



IEC 60947-4-1
Mirror contacts

CWB Contactor Catalog Number Format

*For Reference only. Not intended to create part numbers.

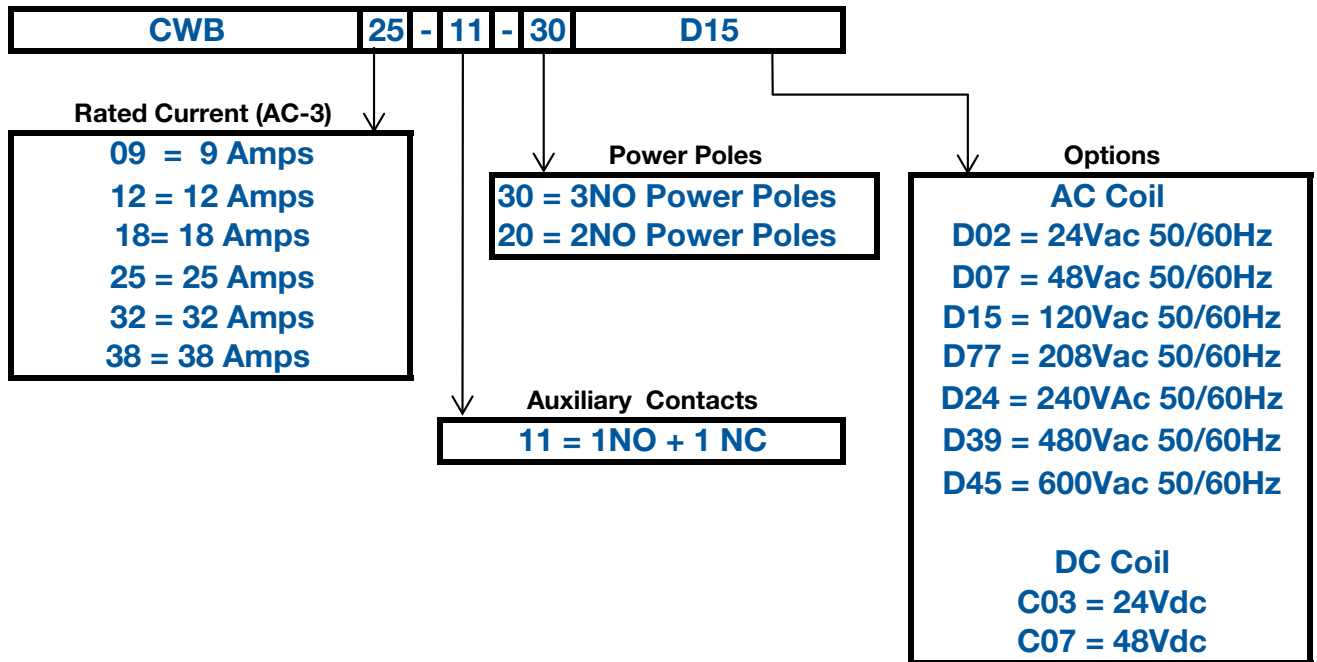

Accessories Overview

Contactors

Overload Relays

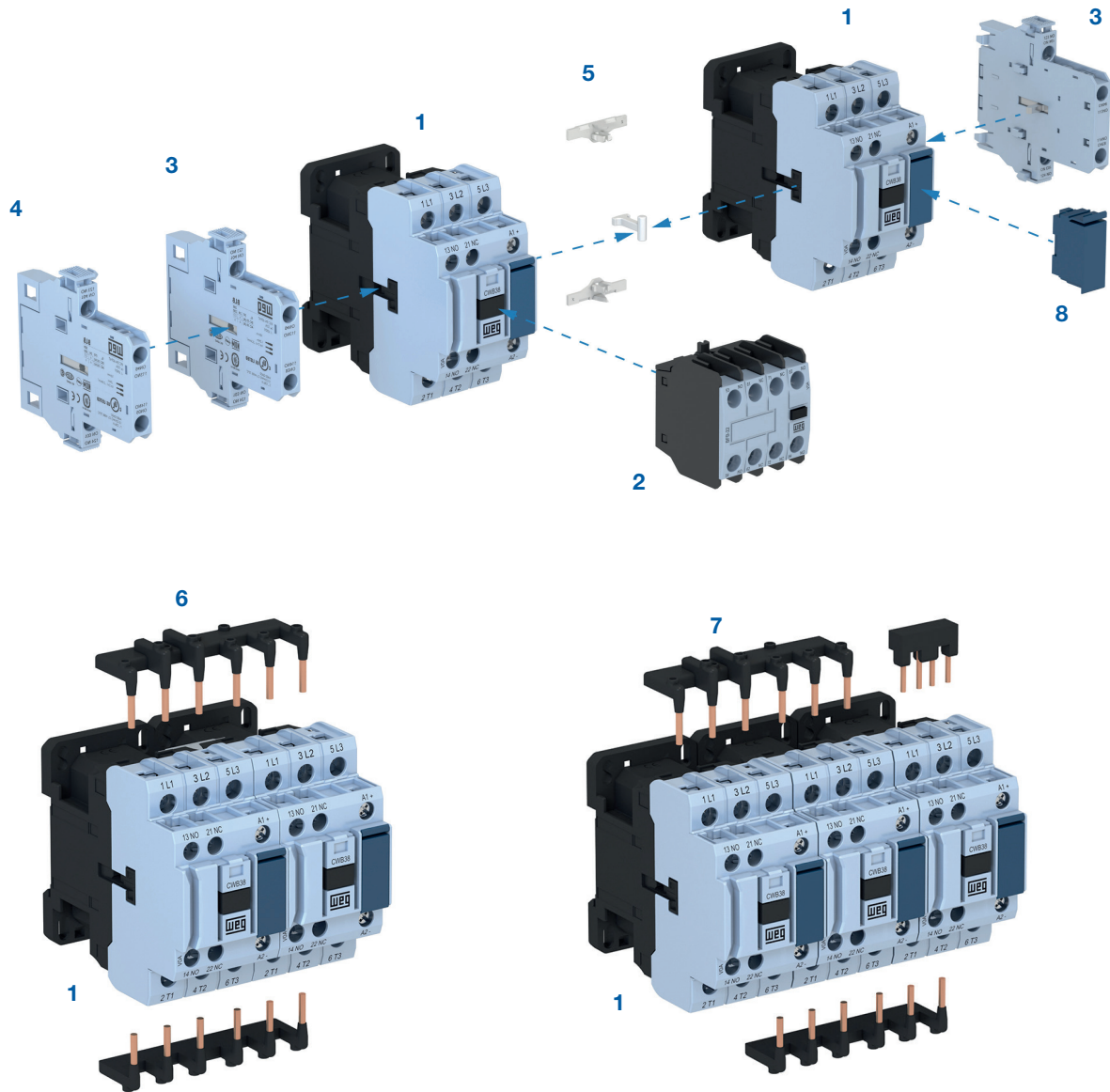

- 1** - Contactors CWB9...38
- 2** - Front mounted auxiliary contact blocks BFB
- 3** - Side mounted auxiliary contact blocks BLB
- 4** - Side mounted auxiliary contact blocks BLRB
- 5** - Mechanical interlock kit IM1
- 6** - Easy connection for reversing starters EC-R1¹
- 7** - Easy connection for star-delta starters EC-SD1¹
- 8** - Surge suppressor blocks RCB, VRB, DIB and DIZB

Notes:

¹UL certification pending

3 POLE CONTACTORS WITH AC COIL

Maximum UL Horsepower						Auxiliary Contacts		Current Rating Amps	Catalog Number	List Price	Multiplier Symbol
Single Phase		Three Phase				N.O.	N.C.				
115V	230V	200V	230V	460V	575V						
3/4	1.5	3	3	5	7 1/2	1	1	9	CWB9-11-30*	\$65	Z1
3/4	2	3	3	7 1/2	10	1	1	12	CWB12-11-30*	\$80	Z1
1	3	5	5	10	15	1	1	18	CWB18-11-30*	\$93	Z1
2	5	7 1/2	7 1/2	15	15	1	1	25	CWB25-11-30*	\$106	Z1 Z1
3	5	10	10	20	25	1	1	32	CWB32-11-30*	\$126	Z1 Z1
3	7.5	10	10	25	25	1	1	38	CWB38-11-30*	\$148	Z1 Z1

*AC COIL VOLTAGE CODE SELECTION FOR CONTACTORS CWB9...CWB38

50/60 Hz	24V	48V	120V	208V	240V	480V	600V
CODE	D02	D07	D15	D77	D25	D39	D45



3 POLE CONTACTORS WITH DC COIL

Maximum UL Horsepower						Auxiliary Contacts		Current Rating Amps	Catalog Number	List Price	Multiplier Symbol
Single Phase		Three Phase				N.O.	N.C.				
115V	230V	200V	230V	460V	575V						
3/4	1.5	3	3	5	7 1/2	1	1	9	CWB9-11-30+	\$93	Z1
3/4	2	3	3	7 1/2	10	1	1	12	CWB12-11-30+	\$111	Z1
1	3	5	5	10	15	1	1	18	CWB18-11-30+	\$125	Z1
2	5	7 1/2	7 1/2	15	15	1	1	25	CWB25-11-30+	\$141	Z1 Z1
3	5	10	10	20	25	1	1	32	CWB32-11-30+	\$180	Z1 Z1
3	7.5	10	10	25	25	1	1	38	CWB38-11-30+	\$230	Z1 Z1

+DC COIL VOLTAGE CODE SELECTION FOR CONTACTORS CWB9...CWB38

Voltage	24V	48V
CODE	C03	C07



Accessories and Spare Parts

Contactors

Overload Relays

Front Mounted Auxiliary Contact Blocks

	For use with	Max. # of additional contacts / contactor	Auxiliary contacts		Catalog #	List Price
			NO	NC		
				CWB9...38		
2	0	BFB-20				
0	2	BFB-02 ¹⁾				
2	2	BFB-22 ¹⁾	\$32.00			
4	0	BFB-40				
0	4	BFB-04 ¹⁾				
3	1	BFB-31 ¹⁾				
1	3	BFB-13 ¹⁾				

Side Mounted Auxiliary Contact Blocks

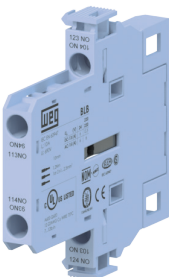
	For use with	Max. # of additional contacts / contactor	Auxiliary contacts		Catalog #	List Price
			NO	NC		
				CWB9...38		
2	0	BLB20				
0	2	BLB02 ¹⁾				
1	1	BLRB11 ^{1,2)}				
2	0	BLRB20 ²⁾				
0	2	BLRB02 ^{1,2)}				

Plug-In Surge Suppressors

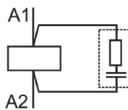
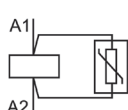
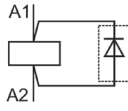
	For use with	Protection Type	Voltage	Diagram	Catalog Number	List Price
	CWB9...38	RC	24...48 V 50/60 Hz		RCB-D53	\$30.00
			50...127 V 50/60 Hz		RCB-D55	
			130...250 V 50/60 Hz		RCB-D63	
		Varistor	12...48 V 50/60 Hz / 12...60 V dc		VRB-E49	
			50...127 V 50/60 Hz / 60...180 V dc		VRB-E34	
			130...250 V 50/60 Hz / 180...300 V dc		VRB-E50	
			277...380 V 50/60 Hz / 300...510 V dc		VRB-E41	
		400...510 V 50/60 Hz	VRB-D73			
		Diode	12...600 V dc		DIB-C33	

Notes: 1) The arrangement of the contacts meets IEC 60947-4-1 Annex F (Mirror Contact) and IEC 60947-5-1 Annex L (Mechanically Linked Contact) requirements.

2) For combination of 2 side-mounted auxiliary contact blocks at the same side of the contactor.

3) The maximum number of auxiliary contacts assembled on the contactor are 4.

Mechanical Interlock Kit

	For use with	Description	Catalog #	List Price
	CWB9...38	Kit for mechanical interlock between two contactors of the CWB line with no additional side space. Contains: 1 interlock unit + 2 fixing clips. <i>Note: Due to differences in physical size, a contactor with AC coil cannot be interlocked to a contactor with DC coil.</i>	IM1	\$12.00

Easy Connection Busbars for Reversing Starters

	For use with	Maximum rated operational power (AC-3) 3-phase motors - IV-poles - 50/60 Hz - 1800 rpm			Catalog #	List Price
	K1 = K2	220 / 240 V kW / HP	380 / 400 V kW / HP	415 / 440 V kW / HP		
	CWB9	2.2 / 3	3.7 / 5	4.5 / 6	EC-R1 ¹	\$49.00
	CWB12	3 / 4	5.5 / 7.5	5.5 / 7.5		
	CWB18	4.5 / 6	7.5 / 10	9.2 / 12.5		
	CWB25	5.5 / 7.5	11 / 15	11 / 15		
	CWB32	7.5 / 10	15 / 20	15 / 20		
CWB38	9.2 / 12.5	18.5 / 25	18.5 / 25			

¹ UL Certification pending

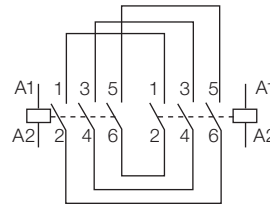
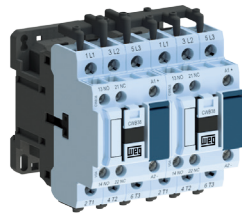

Circuit diagram

Easy Connection Busbars for Star-Delta Starters

	For use with		Maximum rated operational power (AC-3) 3-phase motors - IV-poles - 50/60 Hz - 1800 rpm			Catalog #	List Price
	K1 = K2	K3	220 / 240 V kW / HP	380 / 400 V kW / HP	415 / 440 V kW / HP		
	CWB9	CWB9	3.7 / 5	7.5 / 10	7.5 / 10	EC-SD1 ¹	\$65.00
	CWB12	CWB9	5.5 / 7.5	9.2 / 12.5	11 / 15		
	CWB18	CWB9	7.5 / 10	11 / 15	11 / 15		
	CWB18	CWB12	9.2 / 12.5	15 / 20	15 / 20		
	CWB25	CWB18	11 / 15	22 / 30	22 / 30		
	CWB32	CWB18	15 / 20	22 / 30	30 / 40		
CWB38	CWB25	18.5 / 25	30 / 40	37 / 50			

¹ UL Certification pending

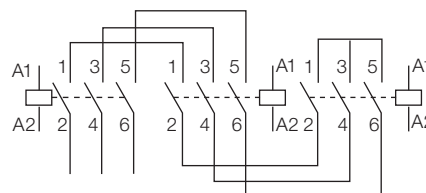
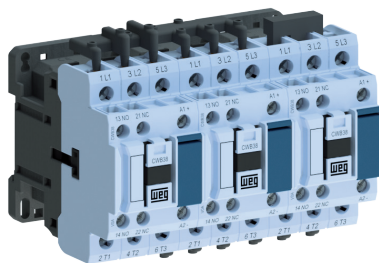

Circuit diagram

Accessories and Spare Parts

Contactors

Overload Relays

Individual Spare Coil for Contactors¹⁾

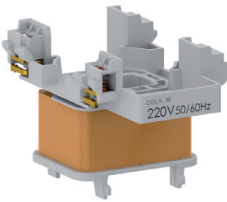
	For use with	Control	Catalog #	List Price
	CWB9...38	AC 50/60 Hz	BRB-38 ♦	\$22.00

Note: 1) Spare DC coils not available.

To complete the reference code, replace “♦” by the appropriate coil voltage code.

Alternating Current

Coil voltage code	D02	D15	D77	D25	D39	D45
V (50/60 Hz)	24	120	208	240	480	600

Note: other AC coil voltages may be available upon request.

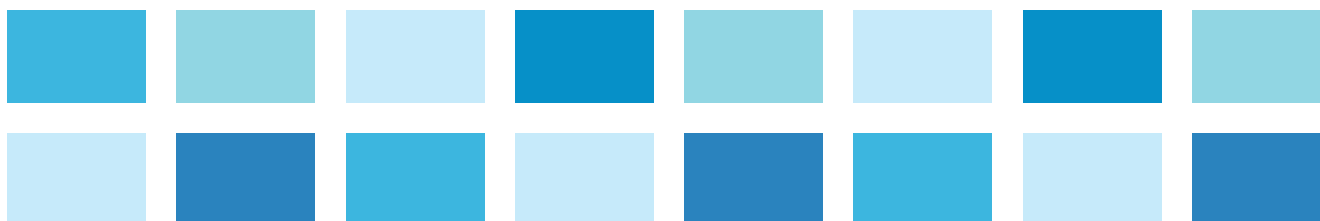

Contactors - Technical Data

Terminal Markings According to EN 50005 and EN 50012

Diagram	Aux Contact Type	NO	NC	Catalog Number
3-pole contactors with built-in auxiliary contacts				
	11	1	1	CWB9...CWB38
Front mounted auxiliary contact blocks				
	20	2	0	BFB-20
	11	1	1	BFB-11
	02	0	2	BFB-02
	40	4	0	BFB-40
	22	2	2	BFB-22
	04	0	4	BFB-04
	31	3	1	BFB-31
	13	1	3	BFB-13

Contactors - Technical Data

Contactors

Overload Relays

Diagram	Aux Contact Type	NO	NC	Catalog Number
Side mounted auxiliary contact blocks				
	11	1	1	BLB-11
	20	2	0	BLB-20
	02	2	0	BLB-02
	11	1	1	BLRB-11
	20	2	0	BLRB-20
	02	2	0	BLRB-02



Contactors - Technical Data

General Data

Reference code		CWB9	CWB12	CWB18	CWB25	CWB32	CWB38
Standards		IEC 60947-1, IEC 60947-4-1, IEC 60947-5-1, UL 508					
Rated insulation voltage U_i (pollution degree 3)	IEC 60947-4-1	(V)			690 V		
	UL, CSA	(V)			600 V		
Rated impulse withstand voltage U_{imp}	IEC 60947-1	(kV)			6 kV		
Rated operational frequency		(Hz)			25...400		
Mechanical lifespan	AC coil	(million cycles)			10		
	DC coil	(million cycles)			10		
Electrical lifespan	le AC-3	1.5	1.5	1.2	1.2	1.2	1.2
Degree of protection (IEC 60529)	Main circuit	IP20 (front)					
	Control circuit and auxiliary contacts	IP20 (front)					
Mounting		By screws or DIN 35 mm rail (EN 50022)					
Number of coil terminals	AC operated contactors	2					
	DC operated contactors	2					
Vibration resistance (IEC 60068-2-6)	Open contactor	(g)			4		
	Closed contactor at U_c	(g)			4		
Shock resistance (½ sine wave = 11 ms - IEC 60068-2-27)	Open contactor	(g)			10		
	Closed contactor at U_c	(g)			15		
Ambient temperature	Operating	-25 °C...+55 °C					
	Storage	-55 °C...+80 °C					
Altitude - rated values up to ¹⁾		3000 m					

Control Circuit - Alternating Current (AC)

Reference code		CWB9...38					
Rated insulation voltage U_i (pollution degree 3)	IEC 60947-4-1	(V)			1000		
	UL, CSA	(V)			600		
Standard coil voltages 50/60 Hz		(V)			12...600		
Coil operating limits							
Coil 50/60 Hz	Pick up	(xUs)			up to 0.8 for 50 Hz / up to 0.85 for 60 Hz		
	Drop out	(xUs)			0.3...0.6		
Power consumption		60 Hz operation			50 Hz operation		
	Sealing	(VA)			7.5		
Coil 50/60 Hz	Power factor	(cos φ)			0.75		
	Pick up	(VA)			75		
					90		
Operation time	(Normally open) contact closing	(ms)			15...25		
	(Normally open) contact opening	(ms)			8...12		
Thermal power dissipation 50/60 Hz		(W)			5...7		

Control Circuit - Direct Current (DC)

Reference code		CWB9...38					
Rated insulation voltage U_i (pollution degree 3)	IEC 60947-4-1	(V)			1000		
	UL, CSA	(V)			600		
Standard coil voltages 50/60 Hz		(V)			12...500		
Coil operating limits							
	Pick up	(xUs)			up to 0.8		
	Drop out	(xUs)			0.2...0.6		
Power consumption		For 1.0 x Us and cold coil					
	Sealing	(W)			5.8		
	Pick up	(W)			5.8		
Operation time	(Normally open) contact closing	(ms)			35...45		
	(Normally open) contact opening	(ms)			8...12		
Average thermal power dissipation		(W)			5.8		

Note: 1) For site altitudes of 3000 to 4000 m, the adjustment factors are (0.90 x I_e and 0.80 x U_i) and for site altitudes of 4000 to 5000 m, the adjustment factors are (0.80 x I_e and 0.75 x U_i).

Contactors - Technical Data

Main Contacts

Reference code		CWB9	CWB12	CWB18	CWB25	CWB32	CWB38	
Rated operational current Ie	AC-3 (Ue ≤440 V)	(A)	9	12	18	25	32	38
	AC-4 (Ue ≤440 V)	(A)	4.4	5.8	8.5	10.4	13.7	13.7
	AC-1 (θ ≤55 °C, Ue ≤690 V)	(A)	25	25	32	40	50	50
Rated operational voltage Ue	IEC 60947-4-1	(V)	690					
	UL, CSA	(V)	600					
Rated thermal current Ith (θ ≤55 °C)		(A)	25	25	32	40	50	50
Making capacity - IEC 60947		(A)	250	250	300	450	550	550
Breaking capacity IEC 60947	Ue ≤440 V	(A)	250	250	300	450	550	550
	Ue = 500 V	(A)	220	220	250	350	450	450
	Ue = 690 V	(A)	150	150	180	250	350	350
Short-time current (no current flowing during recovery time of 15min and θ ≤40 °C)	1s	(A)	210	210	240	380	400	430
	10s	(A)	105	105	145	240	260	310
	1min	(A)	61	61	84	120	138	150
	10min	(A)	30	30	40	50	60	60
Protection against short-circuits with fuses (gL/gG)	@600 V - UL/CSA	(kA)	5					
	Coordination type 1	(A)	20	25	35	40	63	63
Impedance per pole		(mΩ)	2.5	2.5	2.5	2	2	2
Power dissipation per pole	AC-1	(W)	1.5	1.5	2.5	3.2	5	5
	AC-3	(W)	0.2	0.4	0.8	1.2	2	3
Utilization category AC-3								
Rated operational current Ie AC-3	Ue ≤440 V	(A)	9	12	18	25	32	38
	Ue ≤500 V	(A)	7.9	11	15.8	23	28.5	28.5
	Ue ≤690 V	(A)	7	9	12	16.5	21	21
Orientative rated operational power of three-phase motors 50/60 Hz IV poles - 1800 rpm	220 / 240 V	(kW)	2.2	3	4.5	5.5	7.5	9.2
		(HP)	3	4	6	7.5	10	12.5
	380 / 400 V	(kW)	3.7	5.5	7.5	11	15	18.5
		(HP)	5	7.5	10	15	20	25
	415 / 440 V	(kW)	4.5	5.5	9.2	11	15	18.5
		(HP)	6	7.5	12.5	15	20	25
	500 V	(kW)	5.5	7.5	9.2	15	18.5	18.5
		(HP)	7.5	10	12.5	20	25	25
	660 / 690 V	(kW)	5.5	7.5	11	15	18.5	18.5
		(HP)	7.5	10	15	20	25	25
	Utilization category AC-4							
	Rated operational current Ie AC-4	Ue ≤440 V	(A)	4.4	5.8	8.5	10.4	13.7
Ue ≤500 V		(A)	3.9	5.1	7.5	12	13.9	13.9
Ue ≤690 V		(A)	2.8	3.7	5.4	12	12.8	12.8
Orientative rated operational power of three-phase motors 50/60 Hz IV poles - 1800 rpm (200000 cycles)	220 / 240 V	(kW)	1.5	1.5	2.2	3	3.7	3.7
		(HP)	2	2	3	4	5	5
	380 / 400 V	(kW)	2.2	3.7	3.7	5.5	7.5	7.5
		(HP)	3	5	5	7.5	10	10
	415 / 440 V	(kW)	2.2	3	3.7	5.5	7.5	7.5
		(HP)	3	4	5	7.5	10	10
	500 V	(kW)	2.2	3	5.5	7.5	9.2	9.2
		(HP)	3	4	7.5	10	12.5	12.5
	660 / 690 V	(kW)	2.2	3	5.5	9.2	11	11
		(HP)	3	4	7.5	12.5	15	15

Main Contacts

Reference code		CWB9	CWB12	CWB18	CWB25	CWB32	CWB38	
Utilization category AC-1								
Conventional thermal current I _{th} (θ ≤ 55 °C)	(A)	25	25	32	40	50	50	
Rated operational current	θ ≤ 60 °C (U _e ≤ 690 V)	(A)	25	25	32	40	50	
Max. operational power θ ≤ 55 °C (three-phase resistors)	220 / 240 V	(kW)	9.5	9.5	12	15	19	
	380 / 400 V	(kW)	16.5	16.5	21	26	33	
	415 / 440 V	(kW)	19	19	24.5	30.5	38	
	500 V	(kW)	21.5	21.5	27.5	34.5	43	
Current values for connection of	660 / 690 V	(kW)	28.5	28.5	36.5	45.5	57	
	2 poles in parallel		I _e x 1.7					
	3 poles in parallel		I _e x 2.4					
Percentage of maximum operational current	4 poles in parallel		I _e x 3.2					
	600 ops./h	(%)	100	100	100	100	100	

Auxiliary Contacts

Reference code		CWB9...38 (built-in)	BFB (front mounted)	BLB (side mounted)
Standards		IEC 60947-5-1		
Rated insulation voltage U _i (pollution degree 3)	IEC 60947-4-1	(V)	1000	
	UL, CSA	(V)	600	
Rated operational voltage U _e	IEC 60947-4-1	(V)	690	
	UL, CSA	(V)	600	
Conventional thermal current I _{th} (θ ≤ 55 °C)	(A)	10		
Rated operational current I _e				
AC-15 (IEC 60947-5-1)	220 / 230 V	(A)	10	
	380 / 440 V	(A)	4	
	500 V	(A)	2.5	
	660 / 690 V	(A)	1.5	
DC-13 (IEC 60947-5-1)	24 V	(A)	4	
	48 V	(A)	2	
	110 V	(A)	0.7	
	220 V	(A)	0.3	
	440 V	(A)	0.15	
Making capacity	600 V	(A)	0.1	
	U _e ≤ 690 V 50/60 Hz - AC-15	(A)	10 x I _e	
Breaking capacity	U _e ≤ 400 V 50/60 Hz - AC-15	(A)	1 x I _e	
Short-circuit protection max. fuse (gL/gG)	(A)	10		
Control circuit reliability	(V / mA)	17 / 5		
Electrical lifespan	(million cycles)	1		
Mechanical lifespan	(million cycles)	10		
Non-overlapping time between NO and NC contacts	(ms)	1.5		
Impedance per pole	(mΩ)	2.5		



Contactors - Technical Data

Contactors

Overload Relays

UL Ratings

Reference code			CWB9	CWB12	CWB18	CWB25	CWB32	CWB38
Horse power ~ 1Ø	110-120 V	(HP)	0.75	0.75	1	2	3	3
	220-240 V	(HP)	1.5	2	3	5	5	7.5
Horse power ~ 3Ø	200 V	(HP)	3	3	5	7.5	10	10
	230 V	(HP)	3	3	5	7.5	10	10
	460 V	(HP)	5	7.5	10	15	20	25
	575 V	(HP)	7.5	10	15	15	25	25
Short-circuit rating			5 kA - 600 V					
General purpose for 600 V			25	25	32	40	50	50
Coil ratings			12 V ac to 600 V ac, 50/60 Hz					
			12 - 500 V dc					

NEMA Ratings

Reference code			CWB9	CWB18	CWB32
NEMA size			00	0	1
Horse power ~ 3Ø Normal starting duty ¹⁾	200 V	(HP)	1.5	3	7.5
	230 V	(HP)	1.5	3	7.5
	460 V	(HP)	2	5	10
	575 V	(HP)	2	5	10

Note: 1) When operation requires jogging (inching) or plugging or when normal operation requires continued operation in excess of 5 operations per minute, the Normal Starting Duty horsepower ratings are not applied.

Terminal Capacity and Tightening Torque

Reference code			CWB9 - CWB18		CWB25 - CWB38	
Conductors	Connection	Number of conductors	mm ²	AWG	mm ²	AWG
Control and auxiliary circuits		1	1...4	16...12	1...4	16...12
		2	1...2.5	16...14	1...2.5	16...14
		1	1...4	16...12	1...4	16...12
		2	1...4	16...12	1...4	16...12
		1	1...4	16...12	1...4	16...12
		2	1...4	16...12	1...4	16...12
Terminal screw			M4 Flat/Philips			
Power circuit		1	1...6	16...10	1.5...10	16...8
		2	1...4	16...12	1.5...6	16...10
		1	1...6	16...10	2.5...10	14...8
		2	1...6	16...10	2.5...10	14...8
		1	1...6	16...10	2.5...10	14...8
		2	1...6	16...10	2.5...10	14...8
Terminal screw			M3.5 Flat/Philips			
			Tightening torque (N.m / (lb.in))			
Power circuit			1.7 / (15)		2.5 / (22)	

Reference code			BFB (front mounted)		BLB (side mounted)	
Conductors	Connection	Number of conductors	mm ²	AWG	mm ²	AWG
Auxiliary contact blocks		1	1...2.5	16...14	1...2.5	16...14
		2	1...2.5	16...14	1...2.5	16...14
		1	1...2.5	16...14	1...2.5	16...14
		2	1...2.5	16...14	1...2.5	16...14
		1	1...2.5	16...14	1...2.5	16...14
		2	1...2.5	16...14	1...1.5	16
Terminal screw			M3.5 Flat/Philips			
			Tightening torque (N.m / (lb.in))			
Auxiliary circuit			1 / (8.8)		1 / (8.8)	

Electrical Lifespan

Utilization Category AC-1 ($U_e \leq 690 \text{ V ac}$)

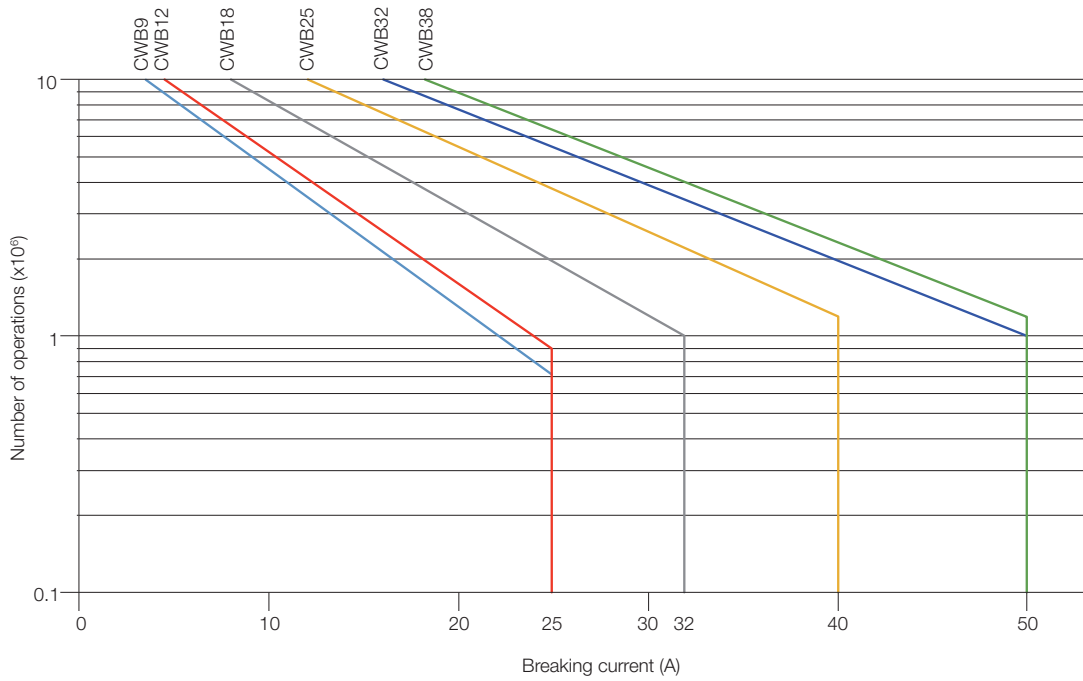

Utilization Category AC-3 ($U_e \leq 440 \text{ V ac}$)

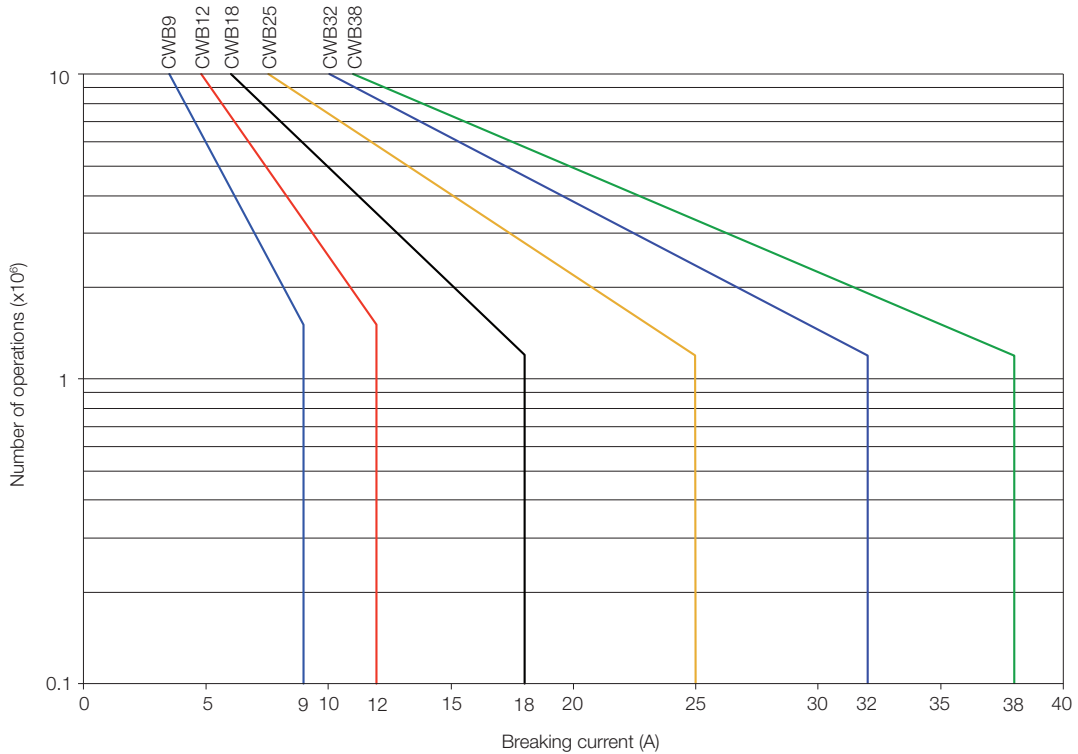

Contactors - Technical Data

Electrical Lifespan

Utilization Category AC-4 ($U_e \leq 440 \text{ V ac}$)

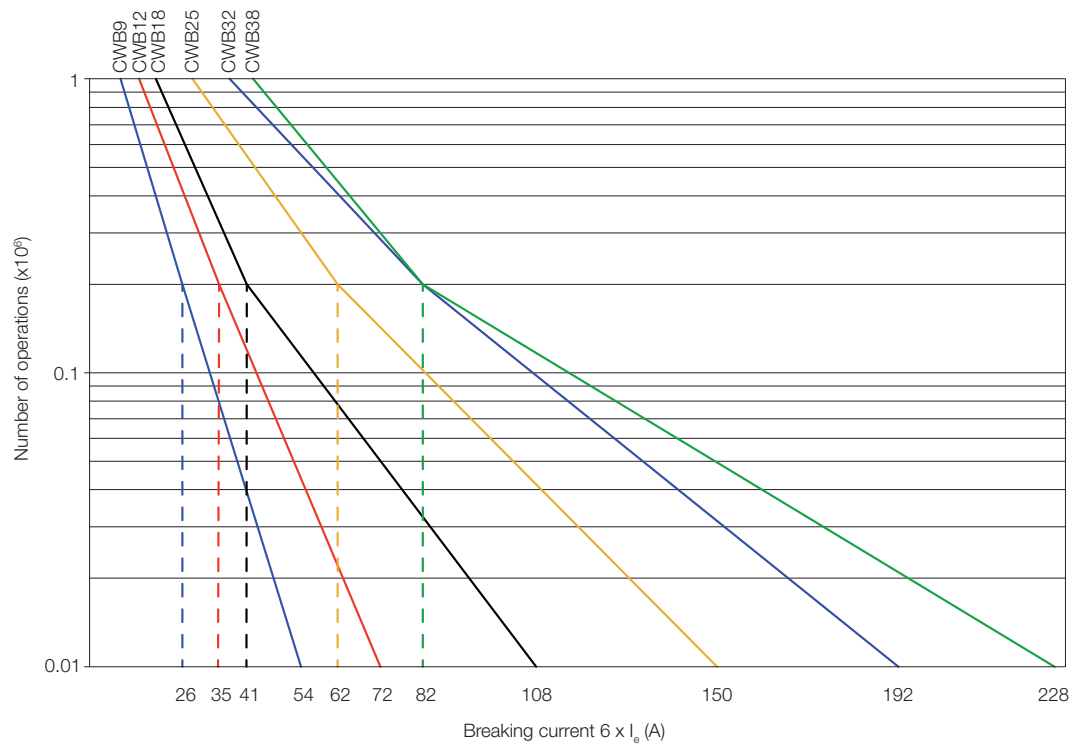

CWB9...18, CWB25...38

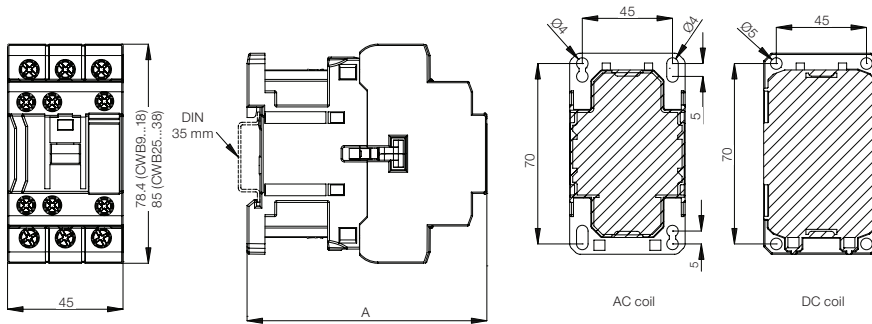

Models	A	
	AC coil	DC coil
CWB9...18	89.5	95.7
CWB25...38	93	102.2

Mounting Position

CWB9...38

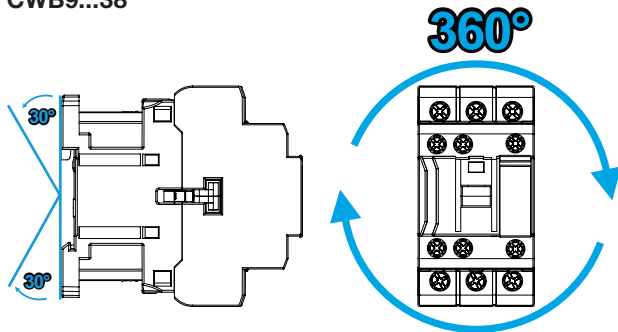

CWB9...18, CWB25...38 + BFB (Front Mounted Auxiliary Contact Block)

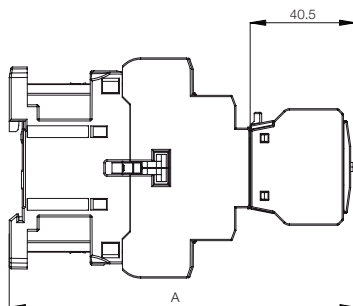

Models	A	
	AC coil	DC coil
CWB9...18	130	136.2
CWB25...38	133.5	142.7

CWB9...18, CWB25...38 + BLB (Side Mounted Auxiliary Contact Block)

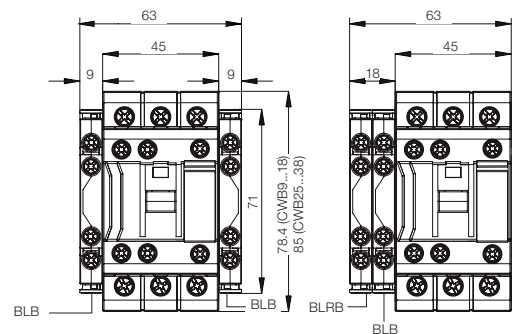

Contactors - Dimensions (mm)

2 x CWB9...38 + IM1 (Mechanically Interlocked)

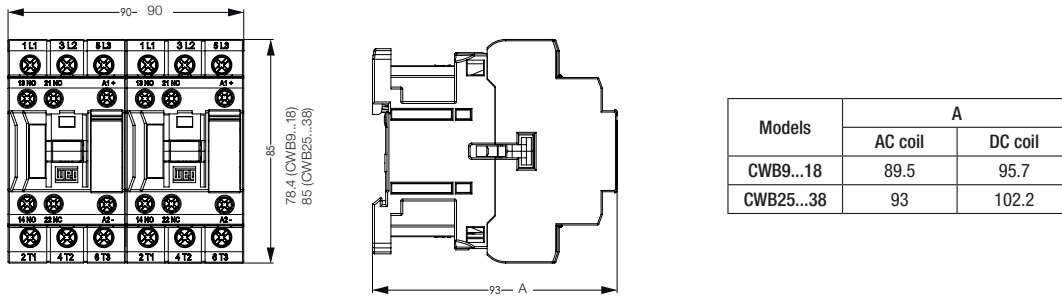

CWB9...18 + Easy Connection Busbars

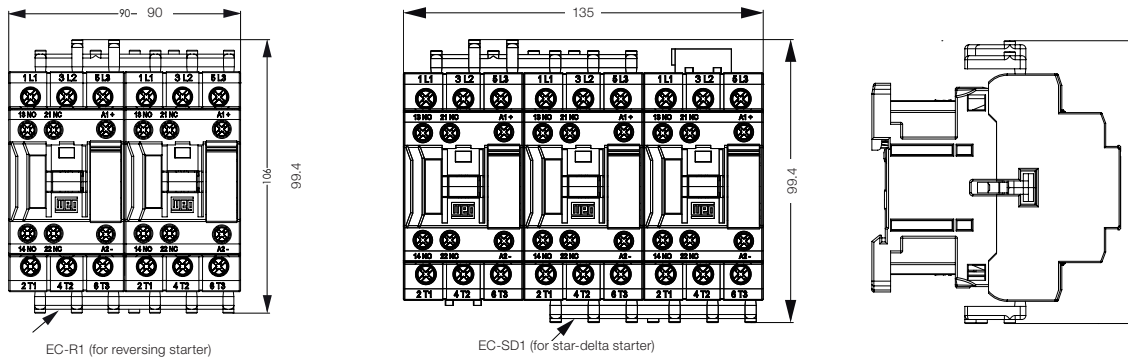

CWB25...38 + Easy Connection Busbars

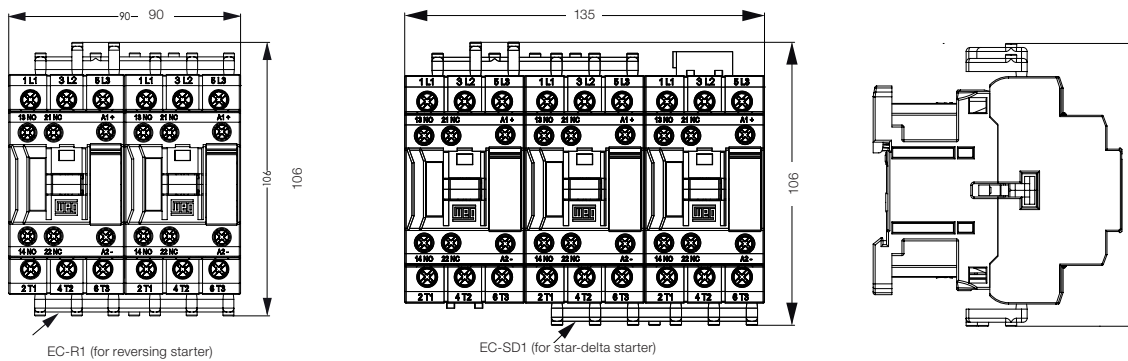



Overload Relays

RW27-2D

RW27-2D Part Number Sequence	B-2
Overload Relay Overview	B-3
Part List and Pricing	B-6
Technical Data	B-7
Dimensions (mm)	B-10

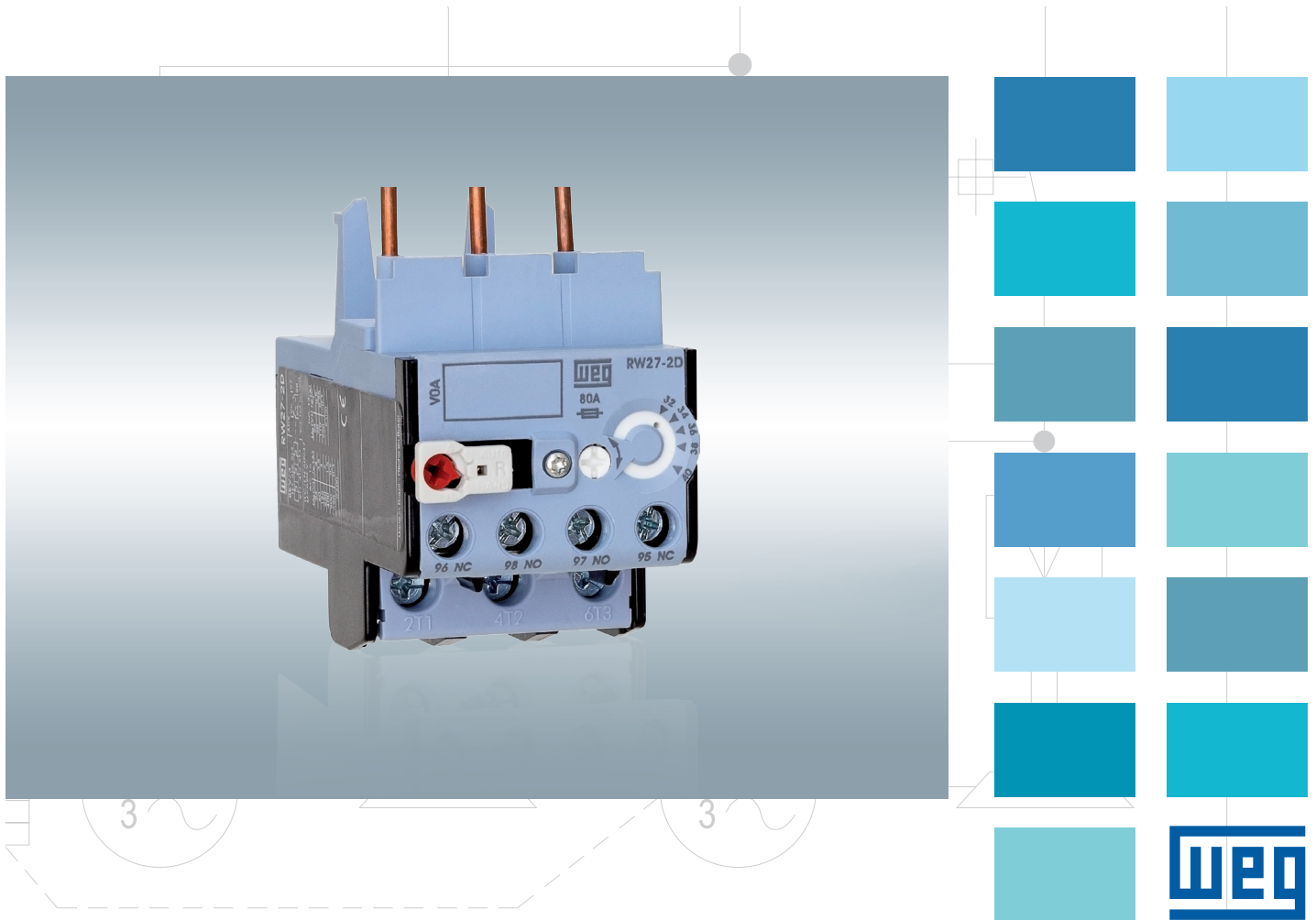

RW27-2D Catalog Number Sequence

RW27 - 2D 3 - U004

Mounts To

CWB9 - CWB38

Power Poles

3 = 3NO Power Poles
2 = 2NO Power Poles

Overload Setting Range

D004 = 0.28 - 0.40 Amps
 C063 = 0.43 - 0.63 Amps
 D008 = 0.56 - 0.80 Amps
 D012 = 0.80 - 1.20 Amps
 D018 = 1.20 - 1.80 Amps
 D028 = 1.80 - 2.80 Amps
 U004 = 2.80 - 4.0 Amps
 D063 = 4.0 - 6.30 Amps
 U008 = 5.60 - 8.0 Amps
 U010 = 7.0 - 0.80 Amps
 D125 = 8.0 - 12.5 Amps
 U015 = 10.0 - 15.0 Amps
 U017 = 11.0 - 17.0 Amps
 U023 = 15.0 - 23.0 Amps
 U032 = 22.0 - 32.0 Amps
 U040 = 32.0 - 40.0 Amps

*For Reference only. Not intended to create part numbers.

Overload Relay

Description

RW27-2D thermal overload relays are designed to be mounted directly with CWB contactors for easy connection to the motor.

Thermal overload relays have no power contacts and cannot disconnect the motor by itself. Motor overloads or phase failures increase the motor current (A), this increase triggers the internal mechanism to trip and simultaneously open the auxiliary contacts, safely disconnecting the motor and protecting it from excessive heating and damage.

The auxiliary contacts, when properly wired in series with the coil of the contactor, will de-energize the coil in the event of a motor overload. Thus, the contactor disconnects the power to the motor and stops its operation.

By design, thermal overload relays have built in thermal memory and once tripped, the relay cannot be reset until the bimetallic strips cool down; thereby allowing the motor to cool before it can be started again.

General Information

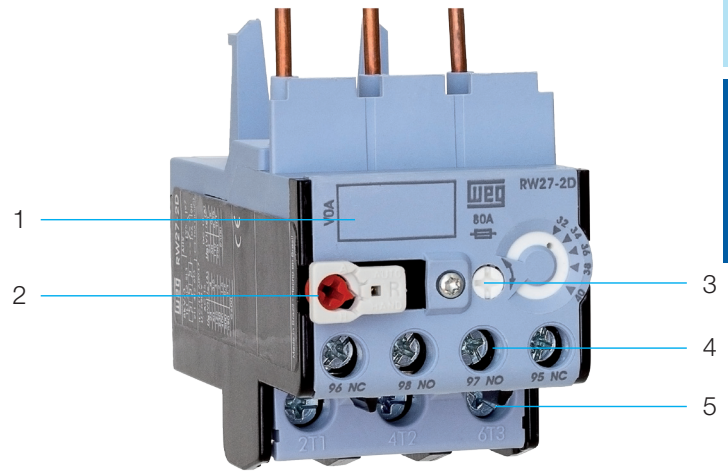

- 1 - Identification tag
- 2 - Multifunction RESET / TEST button
- 3 - Current setting dial
- 4 - Auxiliary contact terminals
- 5 - Main contact terminals

Applications

RW thermal overload relays have been designed to protect three-phase and single-phase AC motors and direct current motors¹⁾. When the RW thermal overload relays are intended to protect single-phase AC loads or DC loads, the connection should be made as shown in the diagrams on page C-9.

RW Thermal Overload Relays in Contactor Assemblies for Wye-Delta Starters

When using thermal overload relays in conjunction with contactor assemblies for wye-delta starters, it should be taken into consideration that only $0.58 (\sqrt{3} / 3)$ x the motor current flows through the main contactor. An overload relay mounted on the main contactor must be set to the same multiple of the motor current.

A second overload relay may be mounted on the wye contactor if it is desired the load to be optimally protected in wye operation. The wye current is 1/3 of the rated motor current. The relay must then be set to this current.

Protection Against Short-Circuit

The RW thermal overload relays must be protected against short-circuits by fuses or circuit breakers.

Ambient Air Temperature Compensation

RW thermal overload relays are temperature compensated. Its trip point is not affected by temperature, and it performs consistently at the same value of current. The time-current characteristics of RWs refer to a stated value of ambient air temperature within the range of -20 °C to +60 °C and are based on no previous loading of the overload relay (i.e. from an initial cold state). For ambient air temperature within the range of +60 °C up +80 °C (maximum ambient air temperature), the current correction factor shown in the table below should be applied:

Ambient air temperature	Current correction factor
65 °C	0.94
70 °C	0.87
75 °C	0.81
80 °C	0.73



Note: 1) Models RW317 and RW407 should be used only with electric motors in alternating current. Data is subject to change without notice.

Overload Relay

Contactors

Site Altitude Compensation

The site altitude and hence the air density play a role with respect to the cooling conditions and dielectric withstand voltage. A site altitude of up to 2000 m is considered as normal in accordance with IEC 60947. For higher altitudes, the current settings on the thermal overload relay should be higher than the motor rated current. On the other hand, the operational voltage must be reduced.

For site altitudes higher than 2000 m, the values for the current and voltage shown in the table below should be applied:

Altitude above sea level (m)	Adjustment factor on the current setting	Maximum operational voltage Ue (V)
2000	$1.00 \times I_n$	690
3000	$1.05 \times I_n$	550
4000	$1.08 \times I_n$	480
5000	$1.12 \times I_n$	420

Overload Relays

Trip Curve Characteristics

Thermal overload relays are designed to mimic the heat actually generated in the motor. As the motor temperature increases, so does the temperature of the overload relay thermal unit.

The motor and relay heating curves have a strong relationship. No matter how high the current drawn by the motor, the thermal overload relay provides protection and yet, does not trip unnecessarily.

Thus, the characteristic tripping curves indicate how the tripping time, starting from the cold state, varies with the current for multiples of the full-load current for three-pole symmetrical loads.

Phase Failure Sensitivity

In order to ensure fast tripping in case of phase loss, protecting the motor and avoiding expensive repairs / corrective maintenance services, RW27-2D thermal overload relays include phase failure sensitivity protection as standard. For this purpose, they have a differential release mechanism that, in the case of phase failure, ensures the de-energized cooled down bimetal strip to generate an additional tripping displacement (simulating an overcurrent that actually doesn't exist). This way, in the event of phase failure, the differential release ensures tripping at a lower current than with a three-phase load (characteristic curve below).

However, for more effective protection against phase failure, specific protective products should be evaluated ensuring that such failure is detected much faster. The curve below shows the tripping time in relation to the rated current. It is also considered average values of the tolerance range and at ambient temperature of 20 °C starting from the cold state.

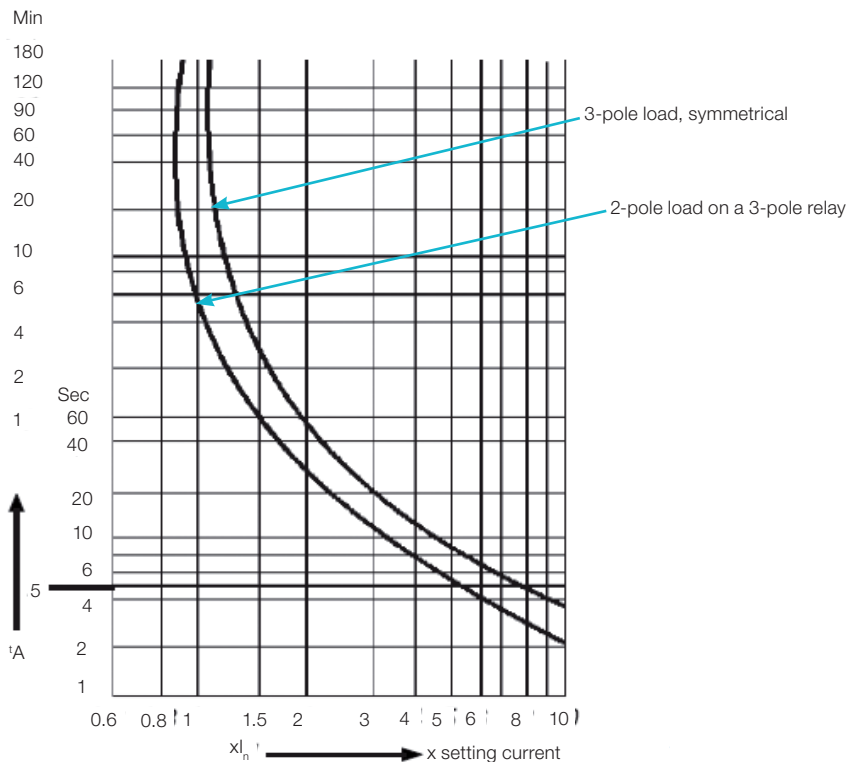

Overload Relay

Multifunction Reset / Test Button

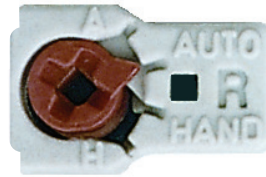

The thermal overload relay has a multifunction **RESET / TEST** button that can be set in four different positions:

- A** - Automatic **RESET** only;
- AUTO** - Automatic **RESET / TEST**;
- HAND** - Manual **RESET / TEST**;
- H** - Manual **RESET** only.

In **HAND** and **AUTO** positions, when **RESET** button is pressed, both NO (97-98) and NC (95-96) contacts change states.

Operation description:

In H (manual RESET only) or A (automatic RESET only) position, the test function is blocked. However in the positions HAND (manual RESET / TEST) or AUTO (automatic RESET / TEST) it is possible to simulate the test and the trip functions by pressing the RESET button.

When set in the H or HAND position the RESET button must be pressed manually to reset the overload relay after a tripping event. On the other hand, when set in A or AUTO position, the overload relay will reset automatically after a tripping event. The H, HAND, AUTO and A function setting is carried out by rotating without pressing the red button and placing it on the desired position of the RESET button.

When changing from HAND to AUTO, the RESET button must be slightly pressed while the red button is rotated.

Functions	H	HAND	AUTO	A
Relay reset	Manual ¹⁾	Manual ¹⁾	Automatic	Automatic
Auxiliary contact trip test 95-96 (NC)	Function is disabled	Test is allowed	Test is allowed	Function is disabled
Auxiliary contact trip test 97-98 (NO)	Function is disabled	Test is allowed	Test is allowed	Function is disabled

Note: 1) A recovery time of a few minutes is necessary before resetting the thermal overload relay.

Recovery Time

The RW thermal overload relays have thermal memory. After tripping due to an overload, the relay requires a certain period of time for the bimetal strips to cool down. This period of time is so-called recovery time. The relay can only be reset once it has cooled down. The recovery time depends on the characteristic tripping curves and the level of the tripping current. After tripping due to overload, the recovery time allows the load to cool down.

Operation in the Output Side of Frequency Inverters

The RW27-2D thermal overload relays are designed for operation on 50/60 Hz up to 400 Hz and the tripping values are related to the heating by currents within this frequency range. Depending on the design of the frequency inverter, the switching frequency can reach several kHz and generate harmonic currents at the output that result in additional temperature rise in the bimetal strips. In such applications, the temperature rise not only depends on the rms value of the current, but on the induction effects of the higher frequency currents in the metal parts of the device (skin effect caused by eddy currents).

Due to these effects, the current settings on the overload relay should be higher than the motor rated current.

RW27-2D Series

Contactors

- Adjustable Trip Current
- Phase Loss Sensitivity
- Trip Class 10
- Built-In Auxiliary Contacts: 1NO + 1NC
- Ambient Temperature Compensation: -4°F to +140°F
- Multi-Function Button: Hand/Auto/Reset



Overload Relays

3 POLE THERMAL OVERLOAD RELAYS - CLASS 10

Matching Contactor	Setting Range [A]		Max. Fuse [A]	Catalog Number	List Price	Multiplier Symbol
	Min.	Max.				
CWB9 - CWB38	0.28	0.40	15	RW27-2D3-D004	\$50	Z2
	0.40	0.63	15	RW27-2D3-C063	\$50	Z2
	0.56	0.80	15	RW27-2D3-D008	\$50	Z2
	0.80	1.20	15	RW27-2D3-D012	\$50	Z2
	1.20	1.80	15	RW27-2D3-D018	\$50	Z2
	1.80	2.80	15	RW27-2D3-D028	\$50	Z2
	2.80	4.00	15	RW27-2D3-U004	\$50	Z2
	4.00	6.30	25	RW27-2D3-D063	\$50	Z2
	5.60	8.00	30	RW27-2D3-U008	\$50	Z2
	7.00	10.0	40	RW27-2D3-U010	\$50	Z2
	8.00	12.5	50	RW27-2D3-D125	\$50	Z2
	10.0	15.0	60	RW27-2D3-U015	\$50	Z2
	11.0	17.0	60	RW27-2D3-U017	\$50	Z2
	15.0	23.0	90	RW27-2D3-U023	\$50	Z2
22.0	32.0	90	RW27-2D3-U032	\$50	Z2	
32.0	40.0	90	RW27-2D3-U040	\$50	Z2	

2 POLE THERMAL OVERLOAD RELAYS - CLASS 10

Matching Contactor	Setting Range [A]		Max. Fuse [A]	Catalog Number	List Price	Multiplier Symbol
	Min.	Max.				
CWB9 - CWB38	0.28	0.40	15	RW27-2D2-D004	\$50	Z2
	0.40	0.63	15	RW27-2D2-C063	\$50	Z2
	0.56	0.80	15	RW27-2D2-D008	\$50	Z2
	0.80	1.20	15	RW27-2D2-D012	\$50	Z2
	1.20	1.80	15	RW27-2D2-D018	\$50	Z2
	1.80	2.80	15	RW27-2D2-D028	\$50	Z2
	2.80	4.00	15	RW27-2D2-U004	\$50	Z2
	4.00	6.30	25	RW27-2D2-D063	\$50	Z2
	5.60	8.00	30	RW27-2D2-U008	\$50	Z2
	7.00	10.0	40	RW27-2D2-U010	\$50	Z2
	8.00	12.5	50	RW27-2D2-D125	\$50	Z2
	10.0	15.0	60	RW27-2D2-U015	\$50	Z2
	11.0	17.0	60	RW27-2D2-U017	\$50	Z2
	15.0	23.0	90	RW27-2D2-U023	\$50	Z2
22.0	32.0	90	RW27-2D2-U032	\$50	Z2	
32.0	40.0	90	RW27-2D2-U040	\$50	Z2	

Technical Data

Contactors

Overload Relays

Main Data

Models			RW27
Standards			IEC 60947-1 and UL 508
Rated insulation voltage U_i (pollution degree 3)	IEC 60947-4-1	(V)	690
	UL, CSA	(V)	600
Rated impulse withstand voltage U_{imp} (IEC 60947-1)		(kV)	6
Rated operational frequency		(Hz)	25...400
Use with direct current			Yes
Maximum operation per hour		(ops./h)	15
Protection degree (IEC 60529)	Main contacts		IP10
	Auxiliary contacts		IP20
	Frontal		IP20
Mounting			Direct on the contactor
Resistance to impact (IEC 60068-2-27 - 1/2 sinusoid)		(g/ms)	10/11
Ambient temperature	Transport and storage		-50 °C...+80 °C
	Operating		-20 °C...+70 °C
	Temperature compensation		-20 °C...+60 °C
Altitude		(m)	2000

Main Contacts

Models			RW27
Rated operational voltage U_e	IEC 60947-4-1	(V)	690
	UL, CSA	(V)	600
Setting current / max fuse (gL/gG) ¹⁾	(A)		0.28...0.4 / 2
			0.43...0.63 / 2
			0.56...0.8 / 2
			0.8...1.2 / 4
			1.2...1.8 / 6
			1.8...2.8 / 6
			2.8...4 / 10
			4...6.3 / 16
			5.6... 8 / 20
			7...10 / 25
			8...12.5 / 25
			10...15 / 35
			11...17 / 40
	15...23 / 50		
	22...32 / 63		
	32...40 / 90		
Average power dissipation per pole		(W)	≤3



Technical Data

Contactors

Auxiliary Circuit

Models			RW27
Standards			IEC 60 947-4-1 and UL 508
Rated insulation voltage U_i (pollution degree 3)	IEC	(V)	690
	UL, CSA	(V)	600
Rated operational voltage U_e	IEC	(V)	690
	UL, CSA	(V)	600
Rated thermal current I_{th} ($\theta \leq 55$ °C)			6
Rated operational current I_e			
AC-14 / AC-15 (IEC 60947-5-1)	24 V	(A)	4
	60 V	(A)	3.5
	125 V	(A)	3
	230 V	(A)	2
	400 V	(A)	1.5
	500 V	(A)	0.5
	690 V	(A)	0.3
UL, CSA			C600
DC-13 / DC-14 (IEC 60947-5-1)	24 V	(A)	1
	60 V	(A)	0.5
	110 V	(A)	0.25
	220 V	(A)	0.1
UL, CSA			R300
Short-circuit protection with fuse (gL/gG)			6
Minimum voltage / admissible current (IEC 60947-5-4)			17 V / 5 mA

Terminal Capacity and Tightening Torque - Main Contacts

Models			RW27
Type of screws			M4 x 10 Phillips
Cable size			
Flexible cable	(mm ²)		1.5...10
Cable with terminal / rigid cable	(mm ²)		1.5...6.0
AWG-wire			14...6
Tightening torque	(N.m)		2.3

Terminal Capacity and Tightening Torque - Auxiliary Contacts

Models			RW27
Type of screws			M3.5 x 10 Phillips
Cable size			
Cable with or without terminal	(mm ²)		2 x 1...2.5
AWG-wire			16...12
Tightening torque	(N.m)		1.5

Diagrams

Motor Protection - Alternating Current

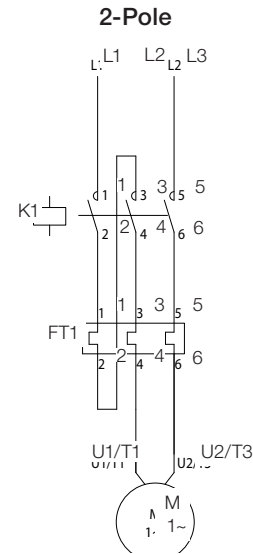
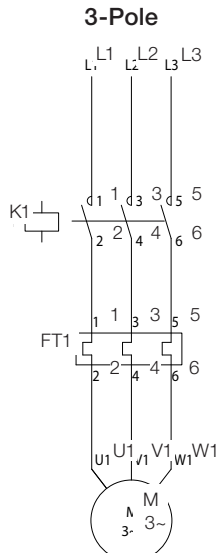

Typical Connection - Contactor + Overload Relay

Direct On Line Starter

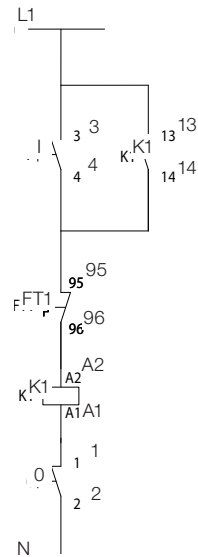

Reversing Direct On Line Starter (2 Directions of Rotation)

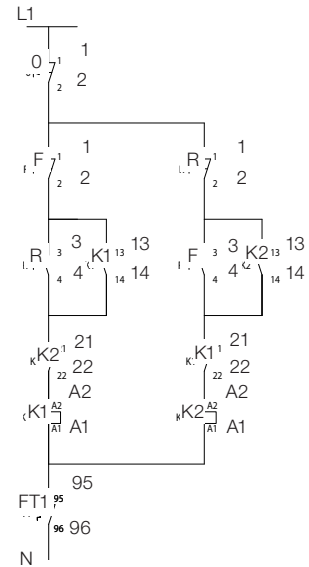

Dimensions (mm)

Contactors

RW27-2D

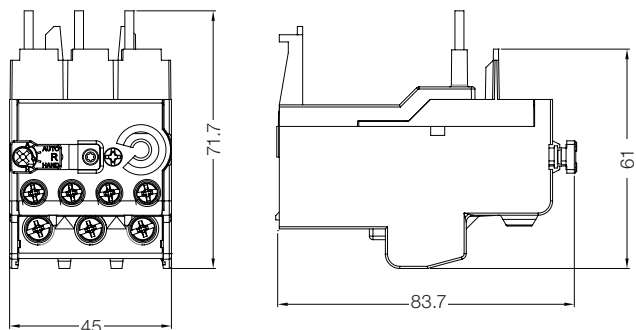

Overload Relays

CWB9...38 + RW27-2D

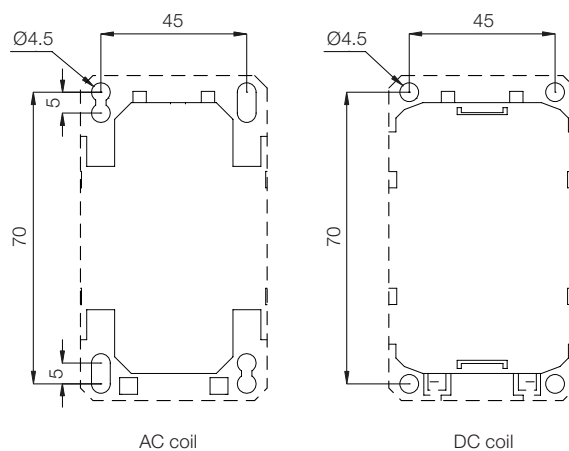
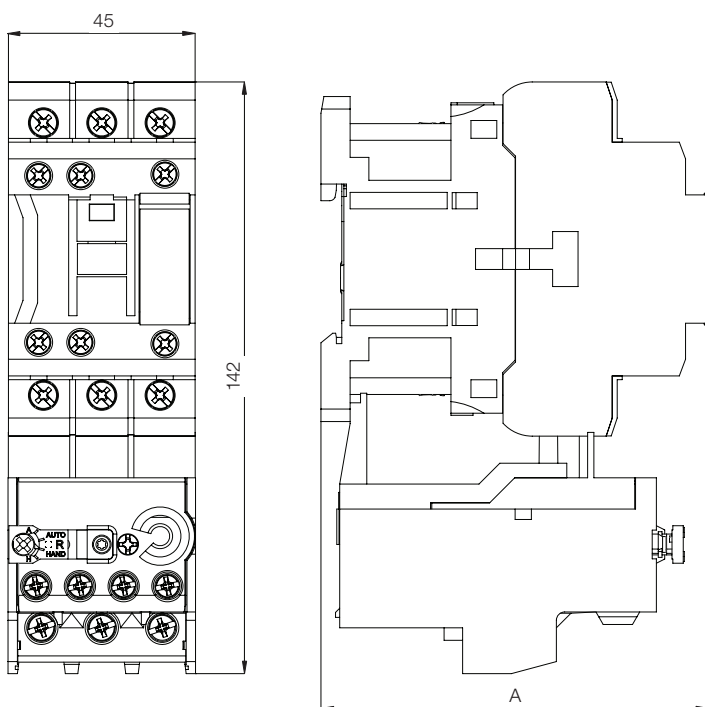

CWB9...18	A	CWB25...38	A
AC coil	89.5	AC coil	93
DC coil	95.7	DC coil	102.2

Mounting Position

RW27-2D

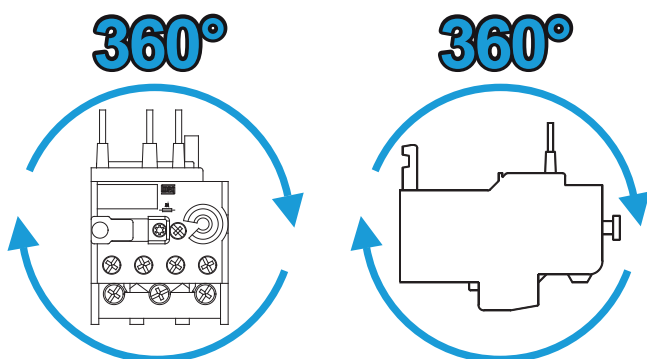





www.weg.net

WEG Electric Corp. offers the following products, and more! With a full range of IEC/NEMA Global Certifications and a full line of products, WEG can supply the right solution for your needs anywhere in the world. To learn more about WEG's products and solutions or to locate a Distributor near you, please call **1-800-ASK-4WEG** or visit **www.weg.net/us**.

**Low Voltage Motors,
Single and 3-Phase, 1/8 – 700HP**

- General Purpose Motors
- Explosion Proof Motors
- Crusher Duty Motors
- IEC Tru-Metric Motors
- Pump Motors including JP/JM
- P-Base Pump Motors
- Oil Well Pumping Motors
- Pool & Spa Motors
- Brake Motors
- Compressor Duty Motors
- Farm Duty Motors
- Poultry Fan Motors
- Auger Drive Motors
- IEEE 841 Motors
- Stainless Steel Wash Down Motors
- Saw Arbor Motors
- Cooling Tower Motors
- Commercial HVAC Motors
- Pad Mounted Motors
- Vector Duty Motors

Large Electric Motors

- Low Voltage 3-phase motors up to 2,500HP
- Motors up to 70,000HP and 13,200V
- Wound Rotor Systems (including starters) up to 70,000HP and 13,200V
- Synchronous Motors up to 70,000HP and 13,200V
- Explosion proof motors (Ex-d) up to 1,500kW and 11kV

Ex-n, Ex-e, Ex-p motors

Variable Frequency Drives

- Low Voltage 1/4 to 2500HP, 230V – 480V
- Medium Voltage 500-8000HP
- Multi-pump systems
- NEMA 4X
- Dynamic braking resistors
- Line and load reactors
- Plug and play technology
- Network communications: Profibus-DP, DeviceNet, Modbus-RTU
- PLC functions integrated
- Complete line of options and accessories

Soft Starters

- 3-1500HP
- Oriented start-up
- Built-in bypass contactor
- Universal source voltage (230-575V, 50/60Hz)
- Network communications: Profibus-DP, DeviceNet, Modbus-RTU
- Complete Line of options and accessories
- MV Soft-starter 3.3kV, 41.6kV: up to 3500HP, Withdrawable Power Stacks, & 8x PT100 Temperature monitoring

Controls

- Mini – Contactors
- IEC Contactors
- Thermal Overload Relays
- Manual Motor Protectors
- Molded Case Circuit Breakers
- Smart Relays
- Enclosed Starters: combination & non-

combination,

- Pushbuttons & Pilot Lights
- Timing & Motor Protection Relays
- Terminal Blocks

Custom Panels

- Custom configured to your specification.
- NEMA 1, 12, 3R, 4 and 4X cabinets
- Quick delivery of preconfigured drives and soft starters
- UL 508 certified
- Low Voltage (230-460)
- Made in the U.S.A.

Generators

- Brushless Synchronous Generators for diesel gen-sets up to 4,200kVA
- Hydro-generators up to 25,000kVA
- Turbo-generators up to 62,500kVA

Power Transformers

- Built and engineered in North America
- Voltages < 500kV
- Ratings 5-300MVA
- Station class, oil filled, round core, copper windings
- Special configurations and designs available!
- Ask your WEG Sales Representative for details.
- Designed, built, and engineered to ANSI standards.

Custom Solution Package Sales

- WEG can package any of its products for ease of sale! Enjoy a single point of contact for the entire package of products and assistance from quote through after-sales support. Ask your WEG Sales Representative for details.

Please contact your authorized distributor:



WEG Electric Corp.
6655 Sugarloaf Parkway
Duluth, GA 30097
Phone: 1-800-ASK-4WEG
www.weg.net

USA Industrial Controls (CWB&RW27-2D)_0315