

# **TAKEX**

# **Takex America Inc Training Manual**

---

**Industrial Automation Group**

**Rayman**

**Rev 1.0**

## Table of contents

1) Sensing Technology .....	3
2) Photoelectric Sensor .....	5
a) Basic components of photo sensor .....	
b) Photoelectric sensor modes of detection .....	6
c) Photoelectric selection sensor question .....	6
d) Photoelectric sensor Types .....	7
i) Thru beam Sensors .....	7
ii) Diffuse .....	9
iii) Background Suppression .....	10
iv) Convergent .....	11
v) Reflex .....	12
vi) Polarized Reflex .....	14
vii) Fiber optics .....	15
viii) Laser .....	16
ix) Color .....	18
x) Mark .....	19
xi) Chemical and Oil resistant .....	21
3) Ultrasonic Sensor .....	22
4) Light Curtains .....	23
5) Hot and Cold Metal Sensor .....	24
6) Terminology .....	26
7) Application Table .....	31

## 1. Sensing Technology in Industrial Automation

A sensor can be thought of as an automatic switch. Sensors have contributed significantly to recent advances in manufacturing technology. Using a sensor makes a process or system more automated and removes the need for a human operator intervention to monitor and control the situation.

In all the major industrial detection applications, sensors are used for detecting presence, absence or distance of parts from or at a reference point. The object to be detected is referred to as a target. When a target is detected the function of the sensor is to change output which in turn will turn a load or turn off the load.

Applications of detection sensor are as follows:



1. Verifying the part have reached a certain position
2. Counting parts
3. Verifying proper placement of parts in the system
4. Making sure edge of part is within the specified position
5. Determining the size of the product
6. Verifying level of liquid or material

The three main categories of sensors used in industrial automation are limit switches, proximity switches( Inductive, Capacitive, photoelectric) sensors, long distance sensing ( Photoelectric, ultrasonic) sensors.

Limit switches use a mechanical actuator requiring the sensor to change its output when object is physically touching the switch. Sensors, such as photoelectric, inductive, capacitive, and ultrasonic, change the output when object is present, but not touching the sensor.

In addition to the advantages and disadvantages of each, sensor technology has been well suited for certain applications. The table on next page elaborates the difference of the sensor technology.

## Takex America Inc Training Manual

Sensor	Advantages	Disadvantages	Application
Limit Switches 	<ul style="list-style-type: none"> <li>• High current capacity</li> <li>• Low cost</li> <li>• Low tech</li> </ul>	<ul style="list-style-type: none"> <li>• Requires physical contact</li> <li>• Very slow response</li> <li>• Contact bounce</li> <li>• Wear and tear</li> </ul>	<ul style="list-style-type: none"> <li>• Interlocking</li> <li>• Basic end of travel</li> </ul>
Inductive 	<ul style="list-style-type: none"> <li>• Resistance to harsh environments</li> <li>• Very predictable</li> <li>• Long life</li> <li>• Easy to install</li> </ul>	<ul style="list-style-type: none"> <li>• Short distance up to 50 mm</li> </ul>	<ul style="list-style-type: none"> <li>• Machine tool industry</li> <li>• Sensing metal objects</li> </ul>
Capacitive 	<ul style="list-style-type: none"> <li>• Detects objects inside container</li> <li>• Can detect non-metallic targets</li> </ul>	<ul style="list-style-type: none"> <li>• Very sensitive to extreme environmental changes</li> </ul>	<ul style="list-style-type: none"> <li>• Level sensing</li> </ul>
Photoelectric 	<ul style="list-style-type: none"> <li>• Senses all kinds of materials</li> <li>• Long life</li> <li>• Longest sensing range</li> <li>• Very fast response time</li> </ul>	<ul style="list-style-type: none"> <li>• Lens subject to contamination</li> <li>• Sensing range affected by color and reflectivity of target object</li> </ul>	<ul style="list-style-type: none"> <li>• Packaging</li> <li>• Material handling</li> <li>• Parts detection</li> </ul>
Ultrasonic 	<ul style="list-style-type: none"> <li>• Senses all materials</li> </ul>	<ul style="list-style-type: none"> <li>• Resolution</li> <li>• Repeatability</li> <li>• Sensitive to temperature changes</li> </ul>	<ul style="list-style-type: none"> <li>• Anti-collision</li> <li>• Doors</li> <li>• Web</li> <li>• Level</li> </ul>

## 2. Photoelectric Sensors

Photoelectric Sensors (PS) use light to detect the presence or absence of an object. All Photo-sensors consist of the sensor, control unit, and output. The source is a light emitting diode that emits a powerful beam of infrared or visible light. The detector is typically a photo diode that senses the presence or absence of light.

### 2a. Basic components of Photo Sensor:

- Source LED
- Photodetector
- Lens (for source and detector)
- Power Circuit ( modulator and demodulator)
- Amplifier
- Output Circuit

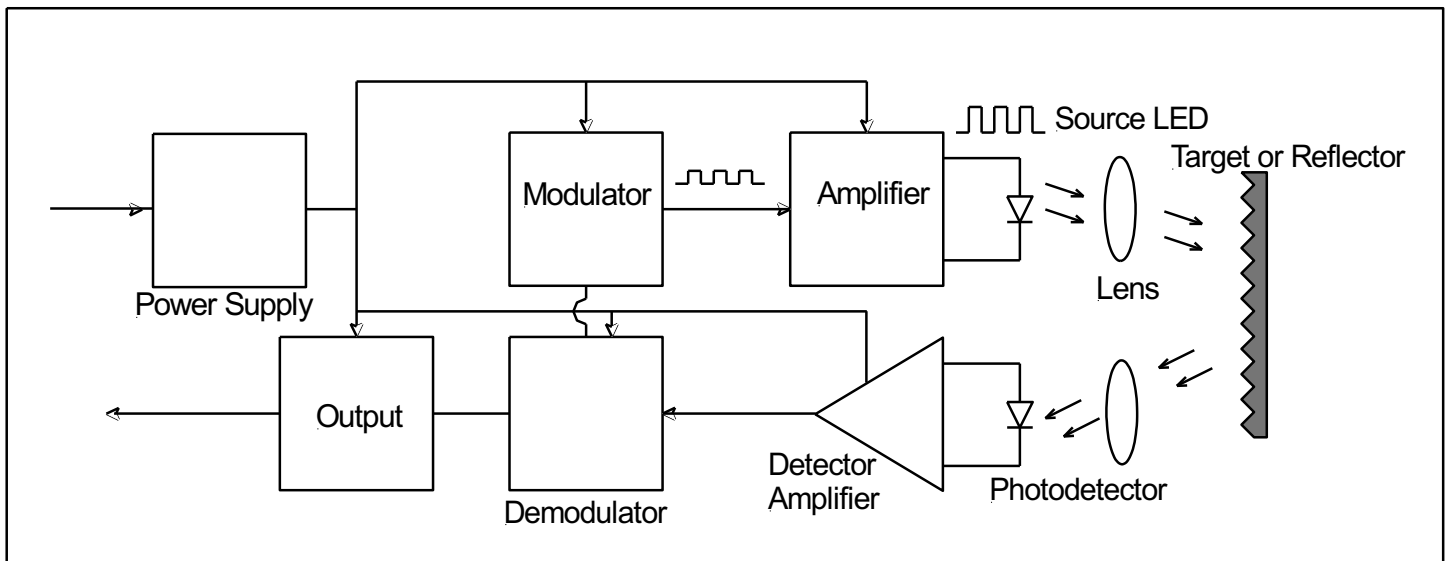

## 2b. Photo Sensor modes of detection:

Thru-beam (Through beam)

Reflex (Retro-reflective / Polarized retro-reflective)

Diffuse (Diffuse reflective)

KEY POINT	CONSIDERATION
Range	How far is the object to be detected?
Environment	How dirty or dark is the environment?
Accessibility	What accessibility is there to both sides of the object to be detected?
Wiring	Is wiring possible to one or both sides of the object.
Size and color	What is the size and the color of the object?
Consistency	Is the object consistent in size, shape, and reflectivity?
Requirements	What are the mechanical and electrical requirements?
Output signal	What kind of output is needed
Logic function	Are logic functions needed at the sensing point?
Integration	Is the system required to be integrated?

## 2c. Photoelectric Selection questions

	Thru-beam, Reflex	Diffuse
Sensing Object	<ol style="list-style-type: none"> <li>1. Size and shape</li> <li>2. Transparency( opaque, translucent, or transparent)</li> <li>3. Speed in ft/s or m/s ( V)</li> </ol>	<ol style="list-style-type: none"> <li>1. Size and shape</li> <li>2. Color</li> <li>3. Material</li> <li>4. Surface(textured or glossy)</li> <li>5. Speed in ft/s or m/s (V)</li> </ol>
Sensor	<ol style="list-style-type: none"> <li>1. Sensing distance (L)</li> <li>2. Restriction of shape or size                             <ol style="list-style-type: none"> <li>a. Sensor</li> <li>b. Retro-reflector</li> </ol> </li> <li>3. Mounting                             <ol style="list-style-type: none"> <li>a. Number of sensors</li> <li>b. mounting pitch</li> </ol> </li> <li>4. Limitation of installation</li> </ol>	<ol style="list-style-type: none"> <li>1. Sensing distance (L)</li> <li>2. Restriction of shape and size</li> <li>3. Mounting                             <ol style="list-style-type: none"> <li>a. Number of sensors</li> <li>b. Pitch</li> </ol> </li> <li>4. Limitation of installation</li> </ol>
Background		<ol style="list-style-type: none"> <li>1. Color</li> <li>2. Material</li> <li>3. Surface</li> </ol>
Environment	<ol style="list-style-type: none"> <li>1. Ambient temperature</li> <li>2. Water, oil or chemicals presence</li> <li>3. Other</li> </ol>	<ol style="list-style-type: none"> <li>1. Ambient temperature</li> <li>2. Water, oil or chemicals presence</li> <li>3. Other</li> </ol>

## 2d. Photoelectric Sensor Types

### Thru-beam Sensing

The thru-beam method requires that the source and detector are positioned opposite each other and the light beam is sent directly from source to detector. When object passes between the emitter and receiver, the beam is broken, signaling detection of object.

Thru-beam detection generally provides the longest range of the three modes and provides higher power at shorter range to penetrate steam, dirt or other contaminants between source and detector.

Alignment of the source and detector must be accurate.

The effective beam area is that of the column of light that travels straight between the lenses.

Because the light from sources is transmitted directly to photo detector, the thru-beam sensing offers the following benefit.

1. Longest range for sensing
2. Highest possible signal strength
3. Greatest light/dark contrast ratio
4. Best trip point repeatability

### Limitation

1. They require wiring of the two components across detection zone
2. It may be difficult to align source and detector
3. If the object detected is smaller than the effective beam diameter, an aperture over the lens may be required

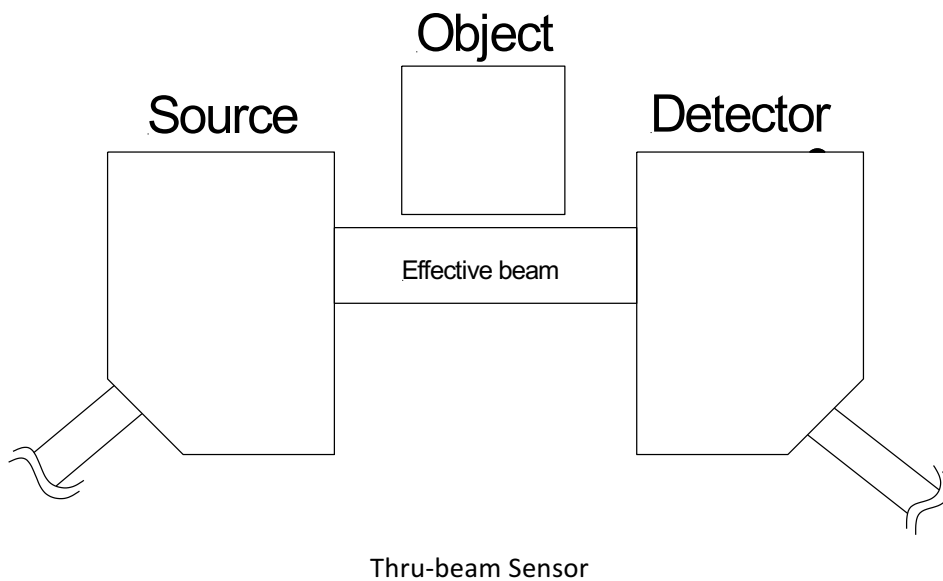

## Application examples:

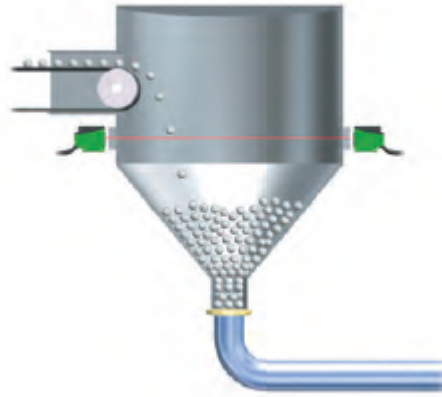
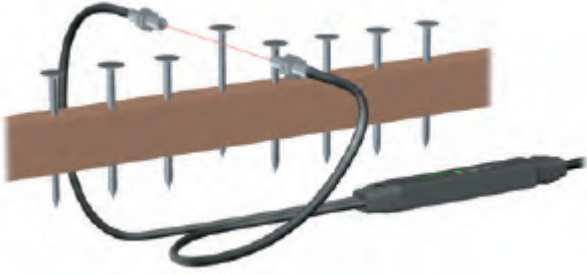



## Diffuse Sensing

The diffuse method requires that the source and detector are installed on the same side of the object to be detected and aimed at a point in front of the sensor. When an object passes in front of the source and detector, light from the source is reflected from the object surface back to the detector, and object is detected.

In general, through beam sensor offers the greatest ranges, followed by reflex, then diffuse sensors.

The optimum range for the diffuse and reflex sensor is more significant than the maximum range. The optimum range is best shown by an excess gain chart.

The detecting zone is controlled by the type, texture, and composition of the object.

Advantages of diffuse sensing:

1. Installation and alignment are simple and involves wiring on one side.
2. It can detect difference in surface reflectivity

Limitation:

1. It has limited sensing range
2. The light/dark contrast sensing range depends on the target object's surface reflectivity.

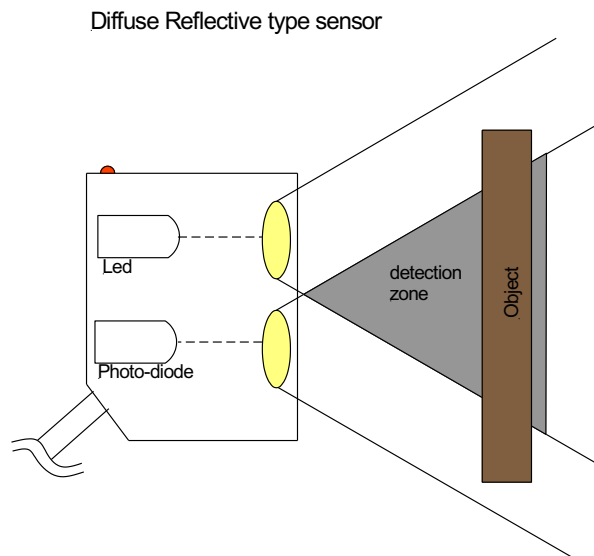

Application example

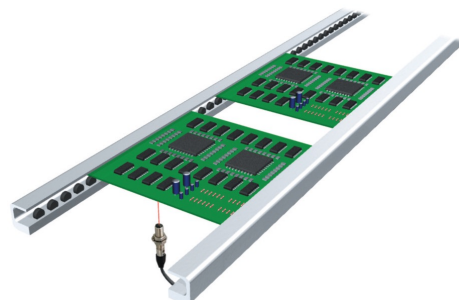

## Background Suppression

Background suppression enables diffuse sensor to have excess gain to a predetermined limit and insufficient excess gain beyond that range where it might pick up objects in motion and yield false detection. By using triangular ranging, sensor developers have created a sensor that emits light that reflects back on the detector from two different target positions. The signal received from the distant target is subtracted from the closer target, providing high excess gain for the closer target.

Background Suppression type sensor

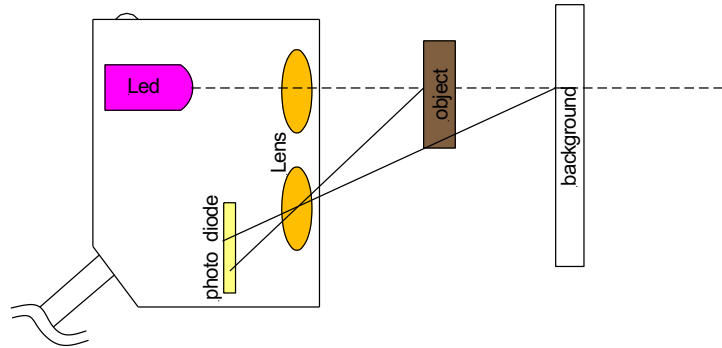

Characteristics of background suppression sensor:

Not affected by Background

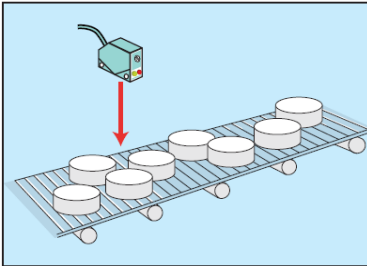

Resistance to soiling of lens

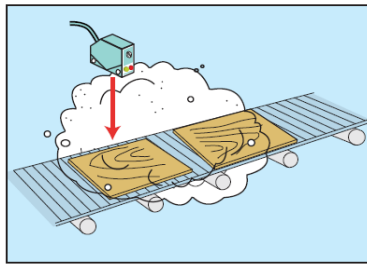

Less influence to color, shape and material of objects

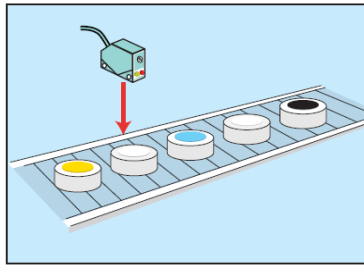

Application examples:

• Detection of bobbins

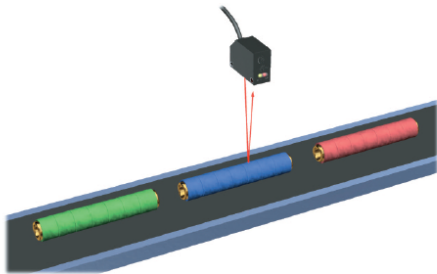

• Detection of tires from a distance

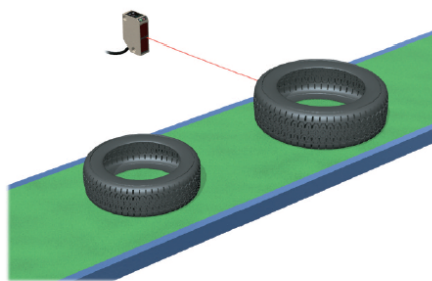

• Prevention of collision of carriage on track

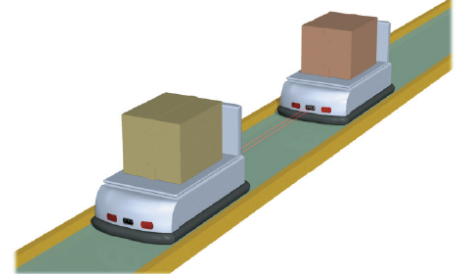

## Convergent Sensing

This is a special variation of diffuse sensing, which uses additional optics to create small, intense and well defined image at a fixed distance in front of the sensor lens. Background objects will not false trigger a convergent reflective sensor since they are cross-eyed and cannot see past a certain point. Convergent sensing is the first choice for sensing transparent materials that remain within sensor's depth of field.

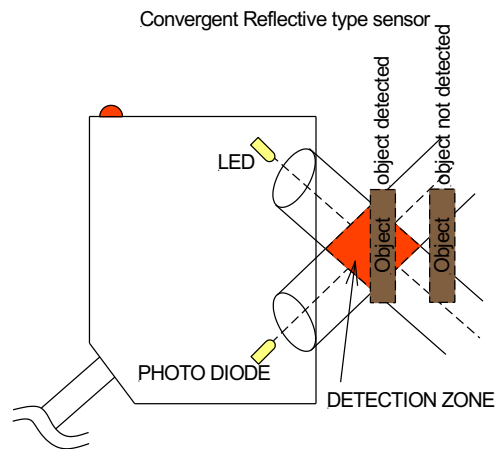

### Application Example

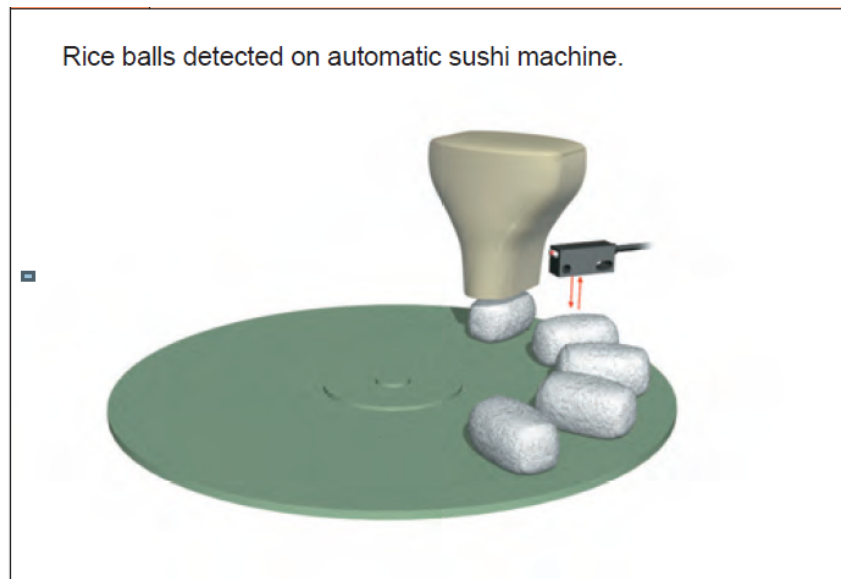

## Reflex Sensing

The reflex method requires that source and detector are installed at the same side of the object to be detected. The light beam is transmitted from the source to a retro-reflector that returns the light to detector. When an object breaks a reflected beam, the object is detected.

The reflex method is widely used because it is flexible and easy to install and provides best cost-performance ratio of three methods. The object to be detected must be less reflective than retro reflector.

Since the light travels in two directions (hence twice the distance), reflex sensors will not sense as far as thru-beam sensors. However reflex sensors offer a powerful sensing system that is easy to mount and does not require that electrical wire being run on both sides of the sensing area. The main limitation of these sensors is that a shiny surface on the target object can trigger false detection.

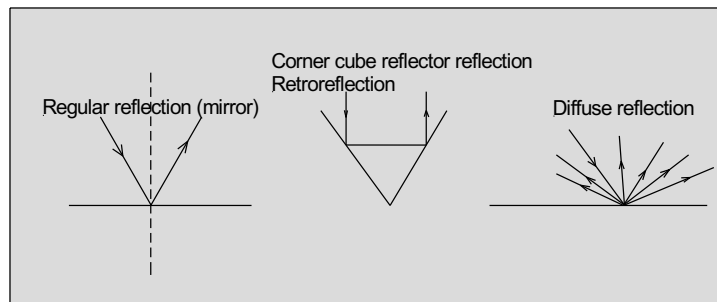

Retro-reflective Reflective type sensor

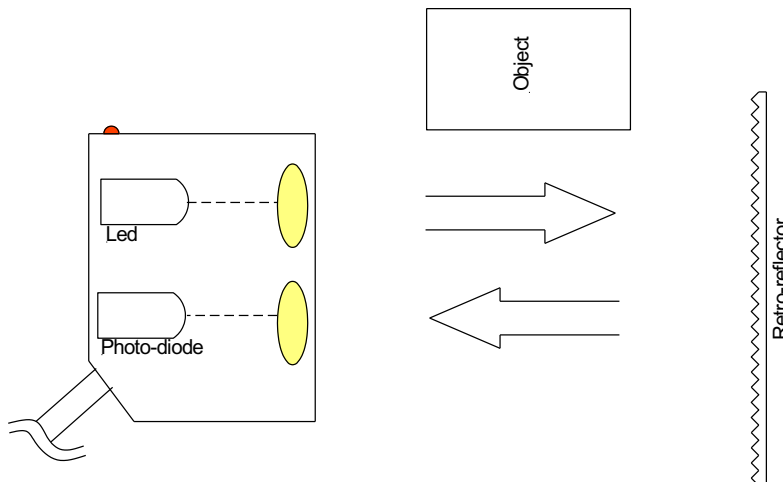

Retro-reflective Application Example:

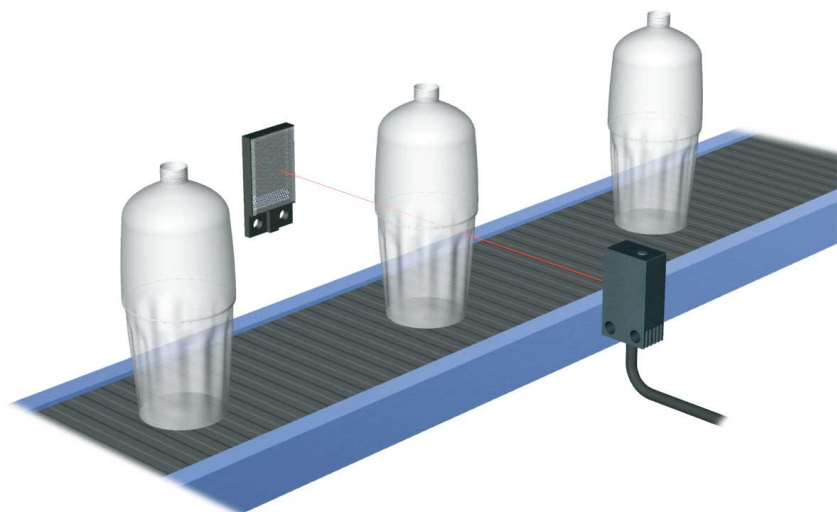
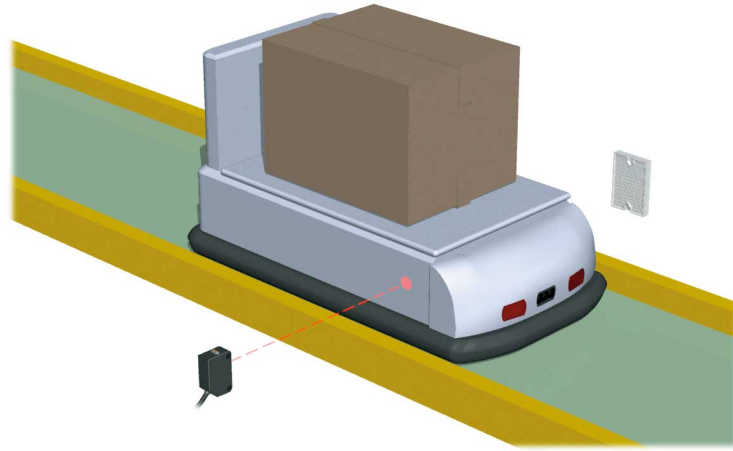

## Polarized reflex

Polarized reflex sensors use a polarizing filter over the source and detector that conditions the light such that the photoelectric control sees only light returned from the reflector. A polarized reflex sensor is used in application where shiny surfaces such metal or shrink wrapped boxes may false trigger the control.

Polarize reflex sensing is achieved by combining some unique properties of polarizer and retro-reflectors. The properties are,

1. Polarizer pass light that is aligned along only one plane
2. Corner –cube reflectors depolarize light as it travels through the face of the retro-reflector

Polarized reflex sensor will not work with reflective tape containing glass beads. Also, shiny object wrapped with clear plastic shrink-wrap will potentially false trigger a polarized reflex control, since under certain conditions these act as corner cube reflector.

The polarized reflex sensor has the following advantages:

1. It is not confused by the first surface reflections from target objects
2. It has a high dark /light contrast ratio
3. It is easily installed and aligned. One side of the sensing only needed be wired

Limitation:

1. Operating range is half that of a non-polarized sensor since much of the signal is lost in the polarizing filters.
2. The sensor can be fooled by shiny objects wrapped with shrink-wrap material.

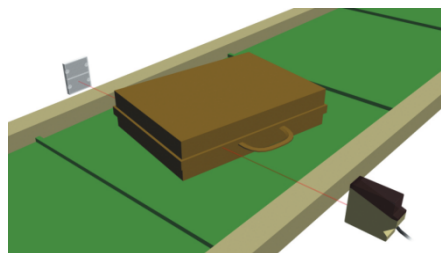
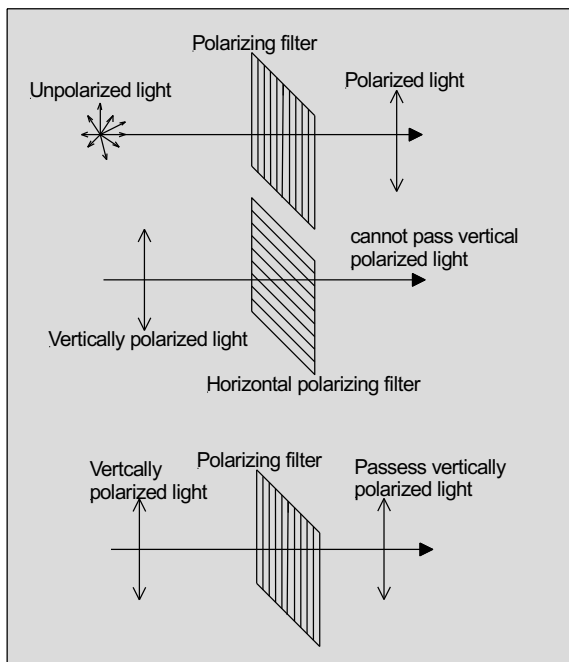

## Fiber Optics Sensing

Fiber optics sensors have largely been applied to application in which their small size has made them convenient replacement for conventional photo electric sensors. The Industry has since discovered that the principle of total internal reflection also applies to small-diameter glass and plastic fibers and this lead to rapid growth. Because optical fibers are small in diameter and flexible, they can bend and twist into confined spaces. Also because they contain no electronics, they can operate in much higher temperatures- as high as 400° F and areas of high vibration. They are limited by sensing distances, which typically are 80 mm diffuse mode and up to 2000 mm in thru-beam mode. Fiber optics can lead to false detection by small drop of water or dirt. There are two basics style fiber optic assemblies, individual fiber optics used by Thru-beam sensor and bifurcated fiber used for diffused sensing.

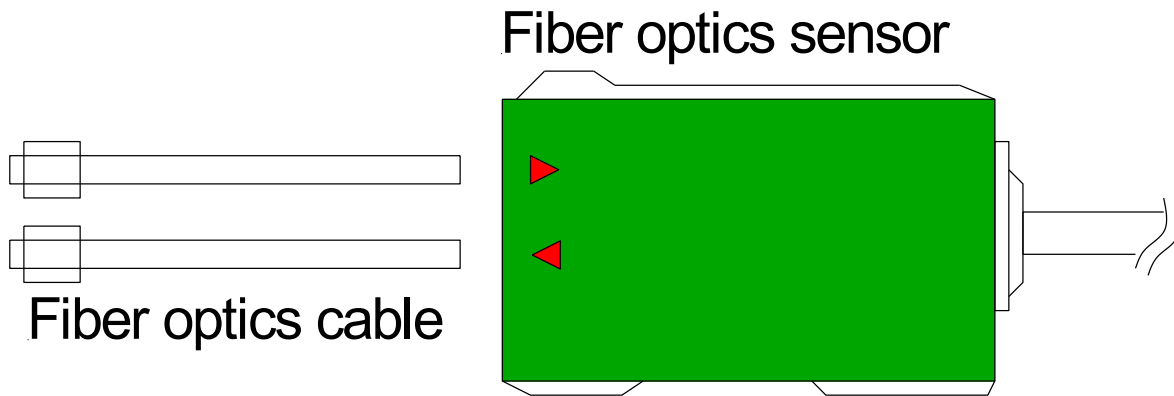

## Application Examples

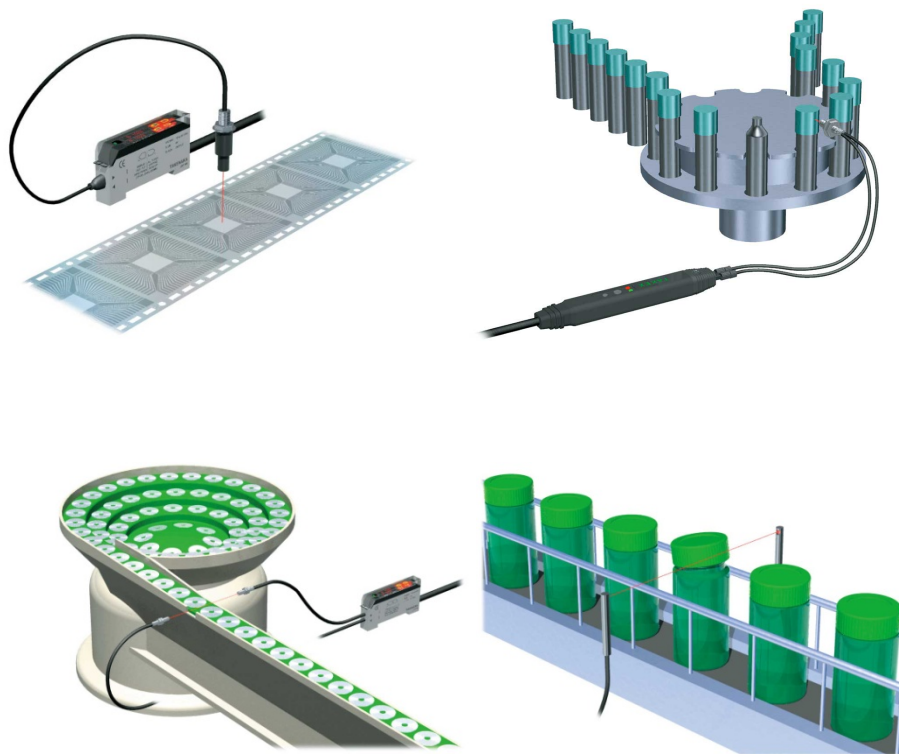

## Laser Sensors

Laser Sensors are especially suited for applications that require high precision.

Laser Sensors combine the alignment advantages of a visible sensing beam with the increased sensing range of a laser. They operate Class 1 and Class 2. These sensors accurately detects small targets and have much longer sensing range compared to standard visible Red and infrared sensors.

When the laser systems are installed, it must be considered, e.g. by correct height of installation, that intentional or accidental looking into the laser beam is prevented. At the place of installation clear warning label are to be applied. Additional protective measures and detailed personnel instructions are necessary. The use of the units at the height of the head or radiation in directions where persons can stay should be avoided. It is obvious that the minimum diameter of the light spot is reached at a defined distance, this distance is given in the data sheet of the respective unit. This distance is determined by the selection of the optical elements. It would be too complicated to make this distance variable. Let us take an analogue example out of the field of photography. A high quality zoom lens is much more complicated and expensive than a lens with fixed focus.

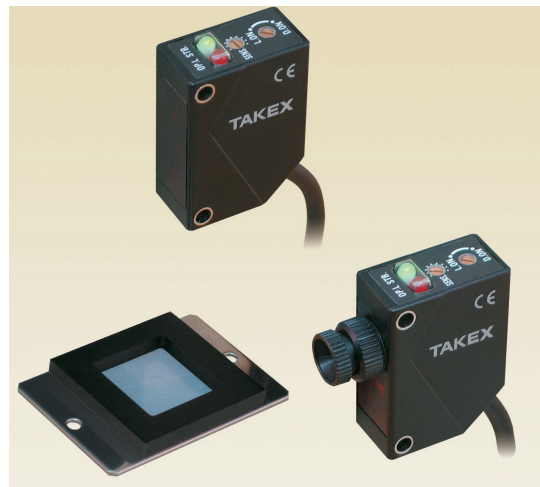

Detecting different cases

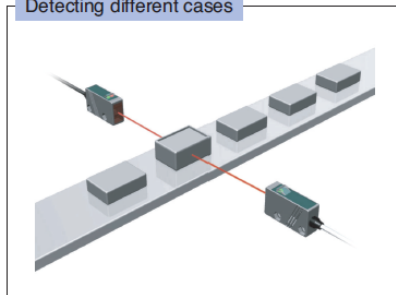

Detecting presence of a board

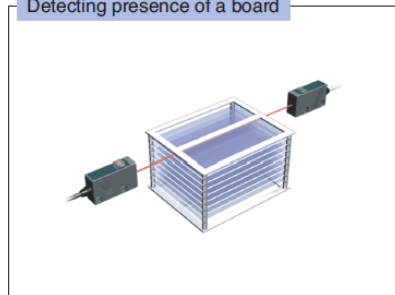

Detecting a mark on a cardboard box from a gap

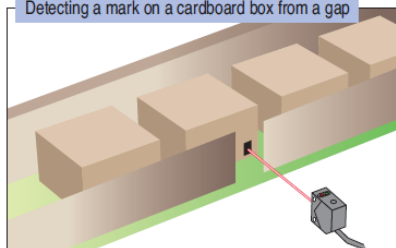

Deciding the location of hybrid board

To decide the location with high precision, using a fine beam.

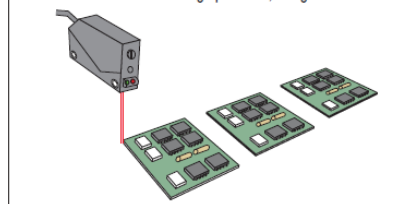



## Color Sensors

Color sensor detects the color of objects without making contact by hue, saturation and brightness. Generally, it judges whether the color of an object is the same with registered color.

The sensors emit light and analyze reflection into three components (RED, GREEN and BLUE) and identify the color according to the proportion of the components. Takex offers two style of color sensor LED and Passive color sensor.

Typical sensing distance -- 13mm ~ 33 mm

Sensor light source:

R: red light G: green light B: blue light

Mark color \ Background color	Black	Blue	Green	Red	Orange	Yellow	White
White	RGB	RGB	RGB	GB	B	B	
Yellow	RGB	RGB	RGB	G	G		B
Orange	RGB	RGB	RGB	GB		G	B
Red	RB	RB	R		GB	G	GB
Green	B	B		R	RGB	RGB	RGB
Blue	B		B	RB	RGB	RGB	RGB
Black		B	B	RB	RGB	RGB	RGB

Detection may not succeed depending on the shading, etc. Be sure to verify operation using samples.



Application examples:

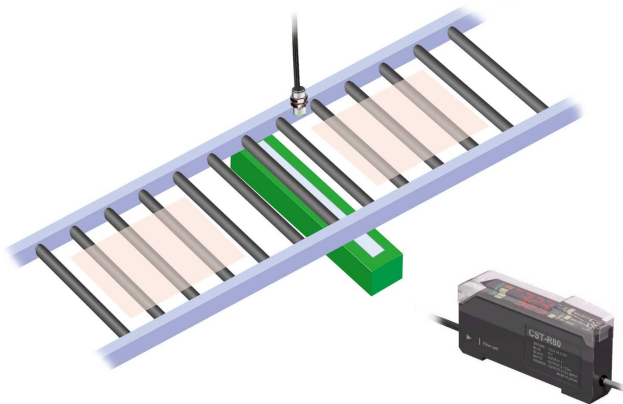

Detecting unevenness in color or brightness of LED illumination modules.

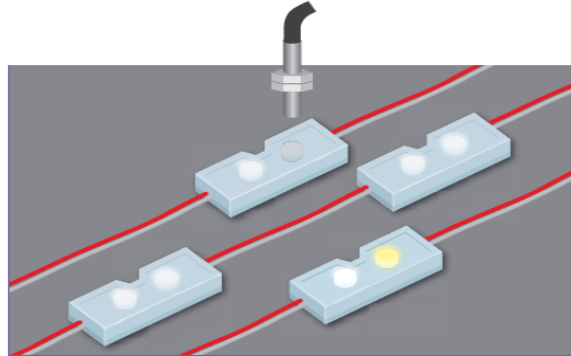

## Mark Sensors

A mark sensor detects the brightness and saturation of color print or paint on objects without making contact with the object. It is mainly used on bag making machines, automatic wrapping machines, printing presses, etc. for various types of control such as detection of register marks in red, blue, yellow, etc. to position for wrapping and cutting. There is a broad range of mark sensors with different applications that also include differentiation between colors where incorrect colors may cause quality control problems and the detection of different levels of reflectance between paint colors on the front and back sides of objects (parts) in a production line checking for the incorrect side facing up. Mark sensors have color variation of light source LED and U-shaped sensor.



## Application examples

Detection of shifted label

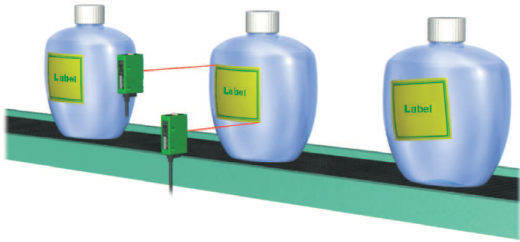

Detection of overlapped label

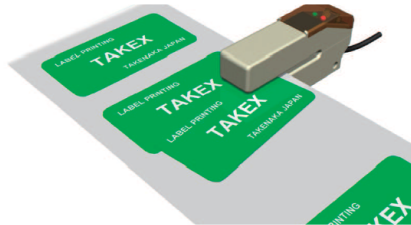

Detection of color registration mark

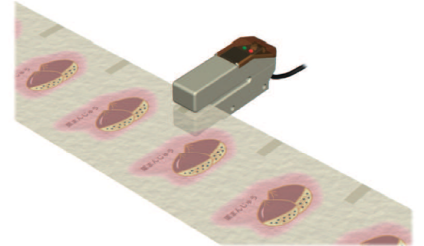

## Oil and Chemical resistant sensors / Sensors for harsh environment

PF series sensors have a protective fluoro-plastic (PFA) covering for enhanced resistance to oils and chemicals. These are capable for immersed applications.



## Application Example

Highly chemical-resistant PFA sensor used for detecting parts in painting department

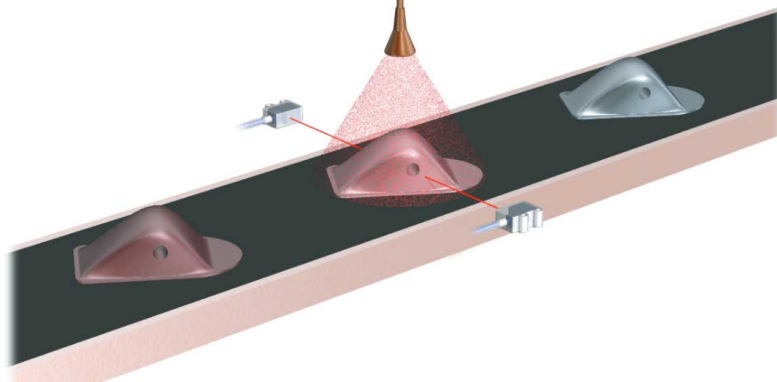

Some of the models have glass lens which can withstand harsh environment compared to ones with a plastic lens. These sensors have a high powered light beam to secure reliable long range detection even in harsh environments.

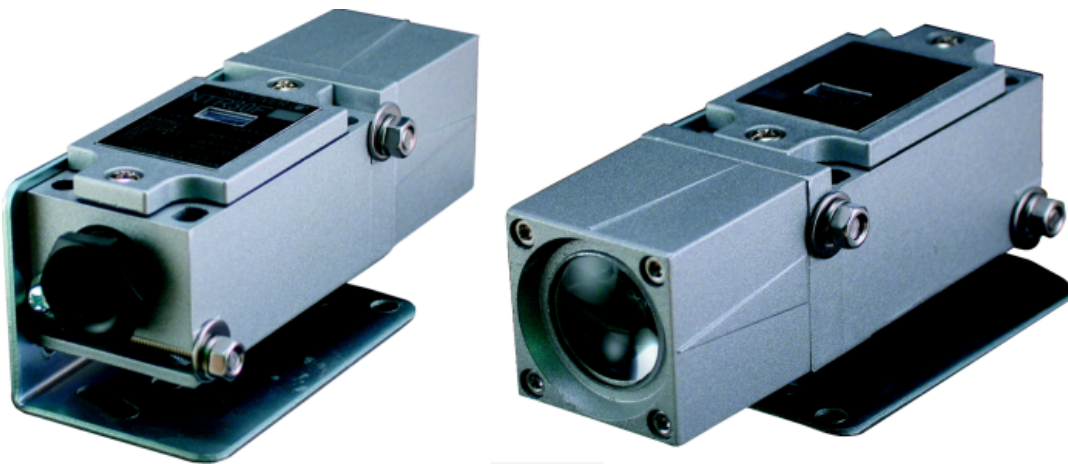

## 3. Ultrasonic Sensors

Ultrasonic sensors detect objects made of various materials regardless of shape, size, color, or surface contours. They operate using high-frequency (100~500kHz) sound waves that are inaudible to human ear. These sensors work well in environments containing dirt, mist, or vapors that cause difficulty for photoelectric sensors.

Typical sensing distance -- 60 mm ~ 6 m



### Application Examples

Controlling liquid level in a pipe



Detecting rolling diameter in a dusty factory

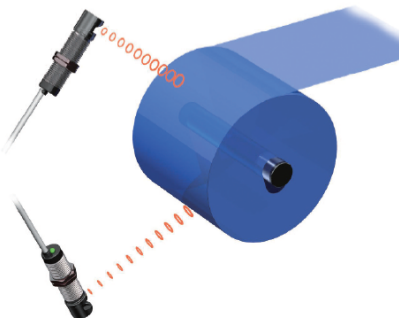

Detect tires regardless of the size

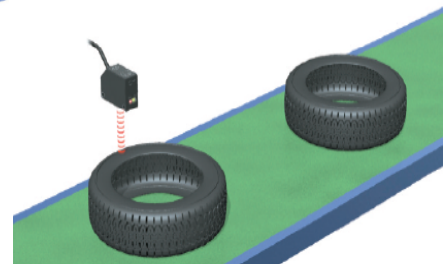

## 4. Light Curtains

Light curtains reliably and cost-effectively protect against access into hazardous points and areas. Light curtains are also used in application to detect falling object from a conveyor. Takex Light curtains are good for various applications but are not safety rated.



Application examples

Robot hand detection

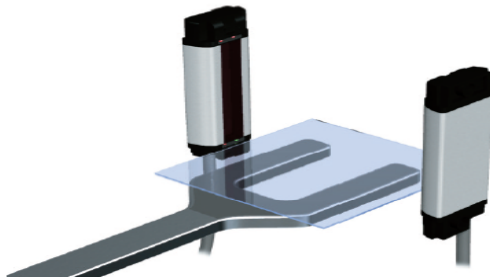

Operation instruction sensor (instruction for bin-picking)

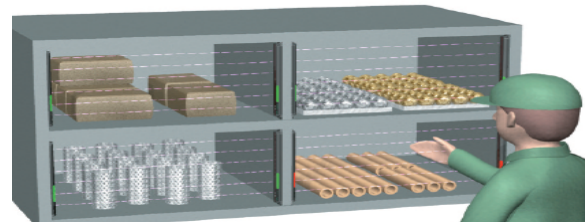

Detection of hole or tear in opaque sheet

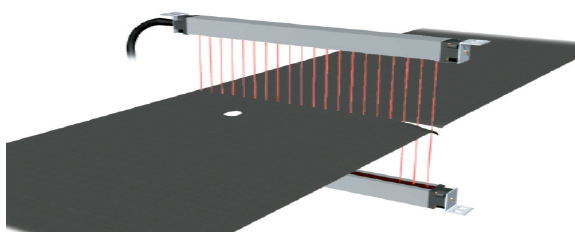

Detection of passage of objects falling at arbitrary points

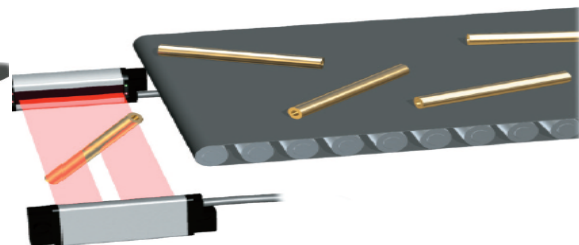

### 5. Hot and Cold Metal Sensors

The HMD (Hot Metal Detector) is used for the detection of hot objects. To do this, the sensor uses the infrared radiation that is emitted by hot materials which is received by an optical system in the sensor. If this radiation exceeds a threshold set in the device (response temperature), the device switches. This happens extremely fast and allows the safe monitoring of rapid processes. Response times of up to 5 ms can be achieved. The principle of the infrared sensor allows the detection of hot objects even at a great distance. Infrared sensors are used wherever inductive sensors cannot be mounted due to the high temperature.

The CMD (Cold Metal Detector) is composed of the transmitter and receiver and has high detection accuracy. It is used even if the object temperature is high and under strong external light.

The punch hall detection sensor (weld point detector) detects the punch hall installed in the welding part of the coil (steel board) that runs continuously between the transmitter and the receiver.

Typical sensing distance -- 250 mm ~ 1 m

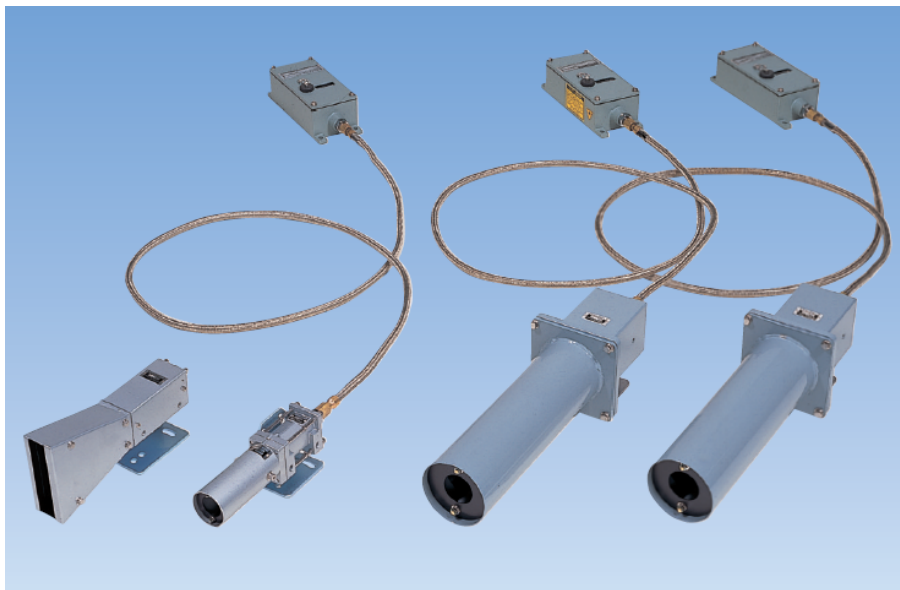



## Application Examples for HMD

Detection of material on forging press

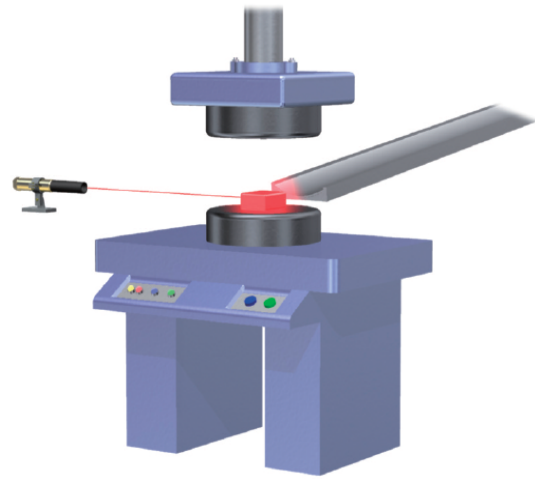
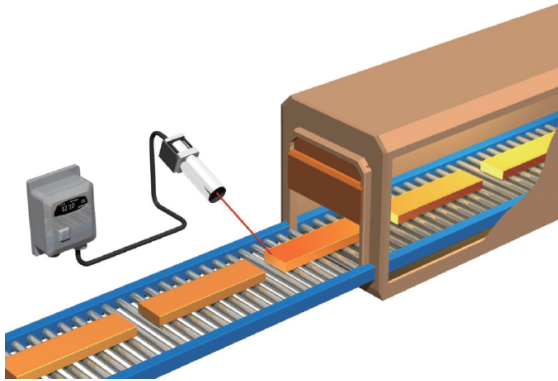

Detection of passage of heated bottles

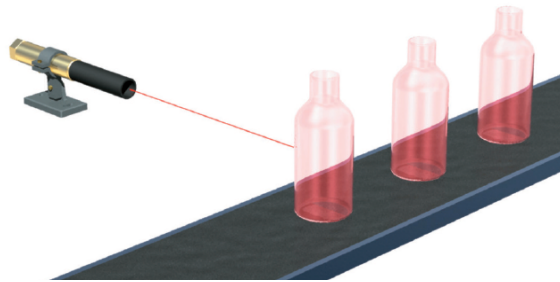

## Application Example for CMD

Detecting the position of material

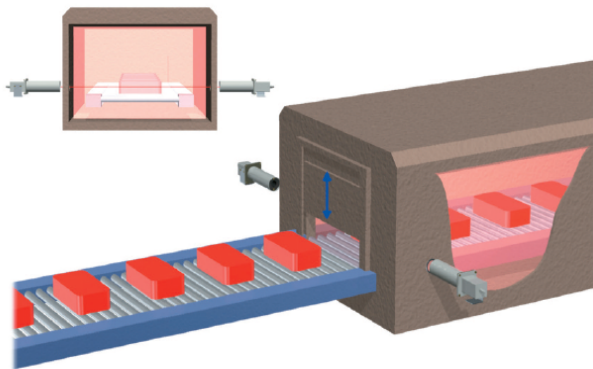

## 6. Terminology

Excess Gain:

Excess Gain is a measure of sensing power available in excess of that required to detect an object. An excess gain of 1 means there is just enough power to detect an object, under best conditions without obstacles placed in the light beam. The distance at which excess gain equals 1 is the maximum range. An excess gain of 100 means there is 100 times the power required to detect an object. Generally more excess gain available at the required range, the more consistently the control will operate. For each distance within range, there is specific excess gain. Through beam controls generally provide the most excess gain, followed by reflex and diffuse.

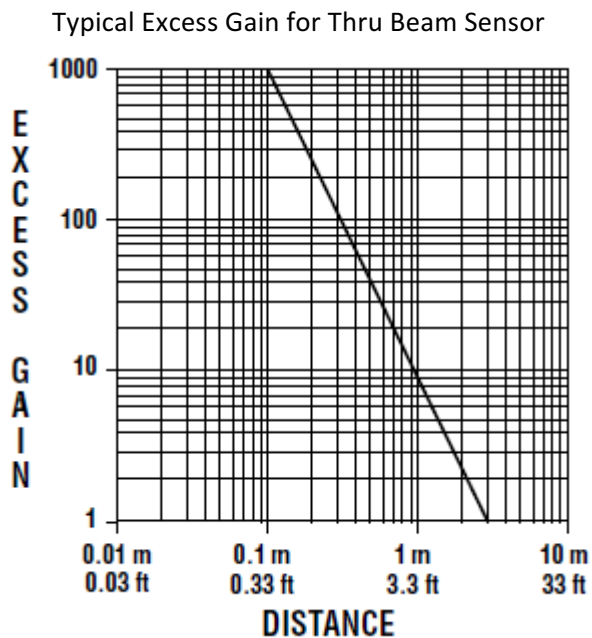

Typical Excess Gain Long Range Diffuse

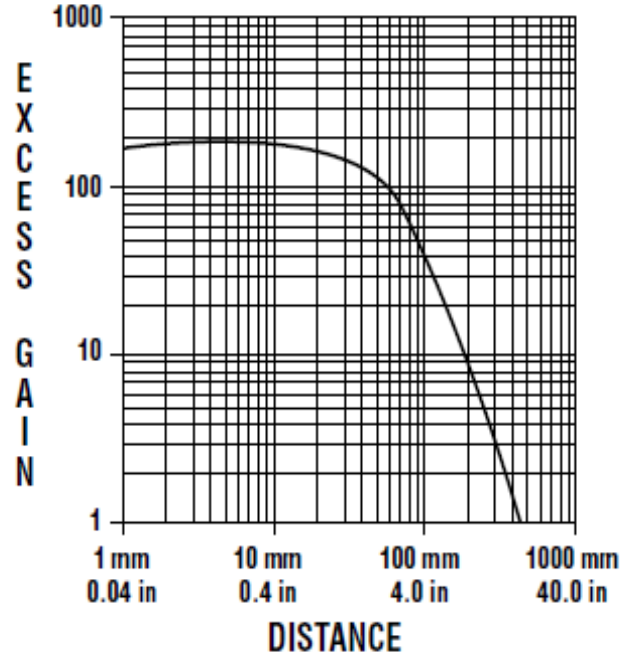

Typical Excess Gain Retro-reflective

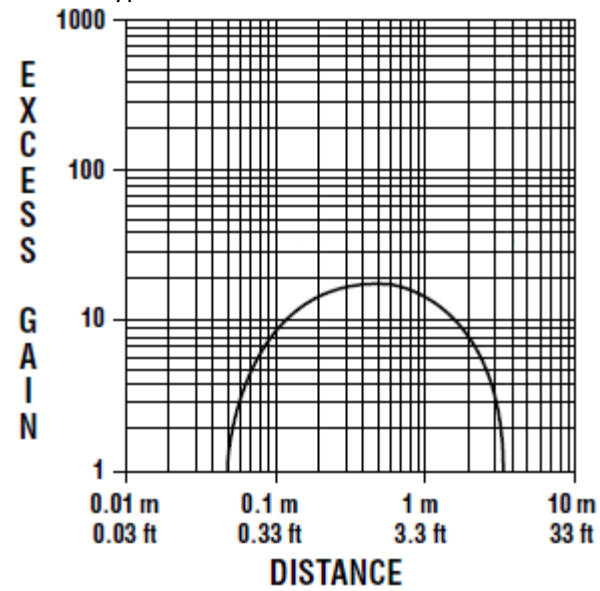

Typical Excess Gain for Background Suppression

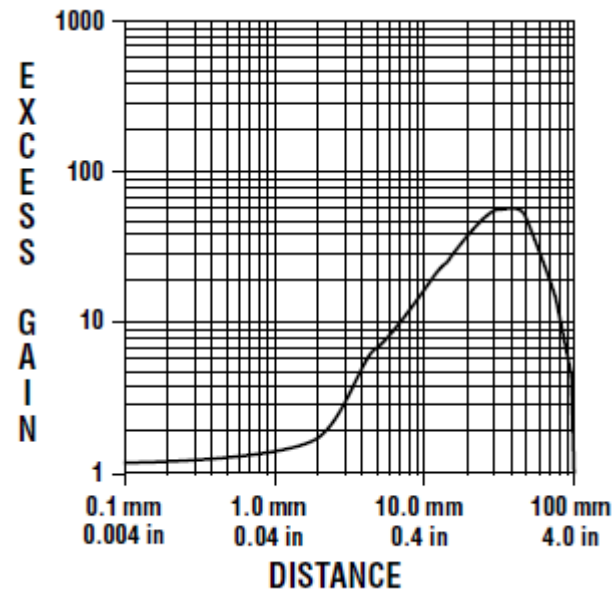

### Typical Excess Gain for Convergent Diffuse Sensor

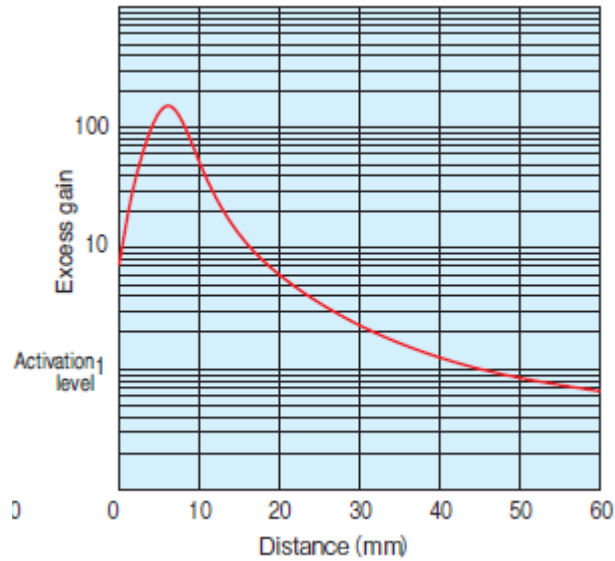

## Beam Pattern

A beam pattern is plotted on a 2-dimensional graph to illustrate how the photoelectric receiver is designed to respond to its emitter. Maximum light energy occurs along the sensor's optical axis. The light energy decreases towards the beam pattern boundaries. The horizontal axis usually shows the range of the sensor.

### Typical Beam Pattern for Thru-Beam sensor

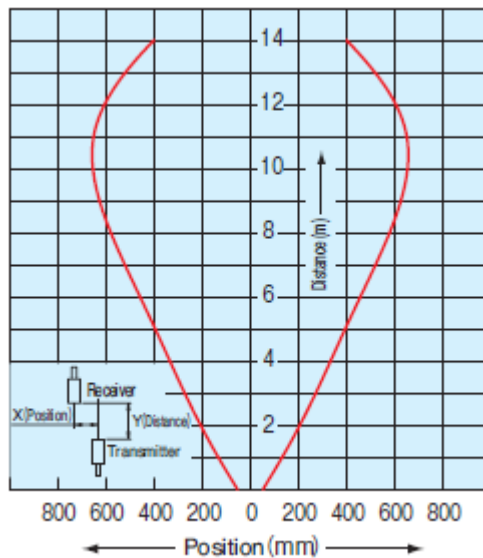

Typical Beam Pattern for Diffuse Reflective sensor

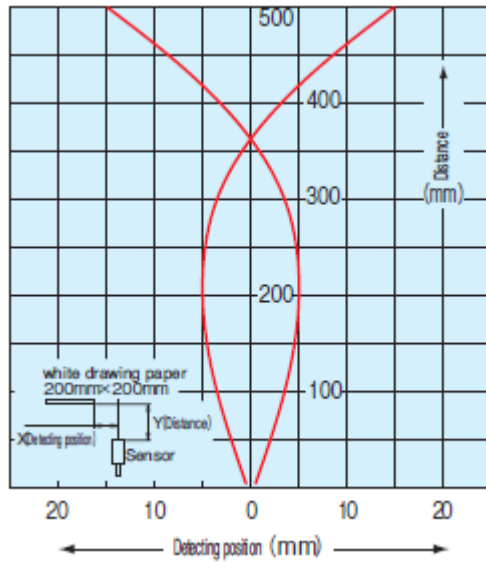

Typical Beam Pattern for Retro Reflective sensor

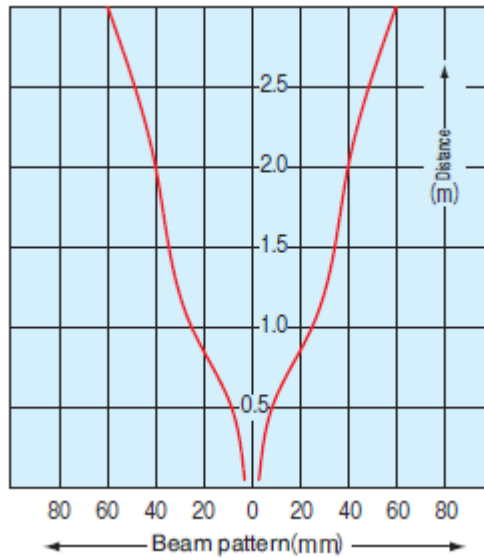

## Contrast ratio:

Contrast measures the ability of photo electric control to detect an object, it is a ratio of a signal strength when detecting an object(light) to a signal strength when there's no object (dark). All other being equal, the sensor that provides the greatest contrast ratio should be selected. For reliable operation a ratio of 10:1 is recommended.

7. Application Table

Sensor	Selection according to industry													
	Delivery/Logistics	Food/packaging/drug	Automated machines	Robot	Semiconductor	Electronic assembly	Steel/heavy Industry	Textile	Chemical/oils	Paper/rubber/plastic	Glass/ceramic	Banking/service	Automobile	
Fiberoptics		●	●	●	●	●				●	●		●	
Embedded amplifier sensor	●	●	●	●	●	●		●	●	●	●	●	●	
Light curtains	●	●		●	●	●	●			●	●		●	
Background suppression	●	●	●	●	●	●	●	●	●	●	●		●	
Ultrasonic Sensors	●	●		●	●	●			●	●	●		●	
AC/DC Power supply sensor	●	●				●						●	●	
Mark Sensors		●	●	●		●				●				
Color Sensors		●	●	●	●	●				●			●	
Image Sensors	●	●		●		●				●				
Photosensor for steel and heavy industries							●				●			
Product specific		●	●		●	●								

Selection according to purpose of detection											
Sensor	Turbidity	Distance	Dimension	Number of rotations	Infrared/temperature	Liquid level	Wafer	Glass substrate	Illuminationcheck	Ignition check	Safety
Fiberoptics	●		●	●		●	●	●	●		
Embedded amplifier sensor	●		●	●		●	●	●			
Light curtains								●			●
Background suppression		●	●	●			●	●			
Ultrasonic Sensors		●				●		●			
AC/DC Power supply sensor											
Mark Sensors	●		●	●							
Color Sensors											
Image Sensors		●	●								
Photosensor for steel and heavy industries					●						
Product specific			●	●		●	●	●	●	●	



Selection according environment							
Sensor	Restricted space	High/low temperature	Dusty	Subject to water splash	Vacuum	Chemical	Explosive environment
Fiberoptics	●	●			●	●	●
Embedded amplifier sensor	●		●	●		●	
Light curtains							
Background suppression	●		●	●			
Ultrasonic Sensors			●	●			
AC/DC Power supply sensor							
Mark Sensors							
Color Sensors							
Image Sensors							
Photosensor for steel and heavy industries			●	●	●		
Product specific					●	●	●

### References:

Sensor Handbook by Dr. Sabine Soloman

Photoelectric Sensors & Controls, selection & application Mr. Scott Juds

Takex 2013 Catalog