

480 Rated Voltage, 600 Max Voltage, High Z, Impedance.								
Part Number	Horsepower (HP)	Motor Amps (A)	Maximum Amps (A)	Inductance (uH)	Weight (LBS)	Losses (W)	Available Lug Kit	Terminal Hole Size (Inches)
KDRS2HE01	700	840	840	37.2	590	1454	SLK16	0.53

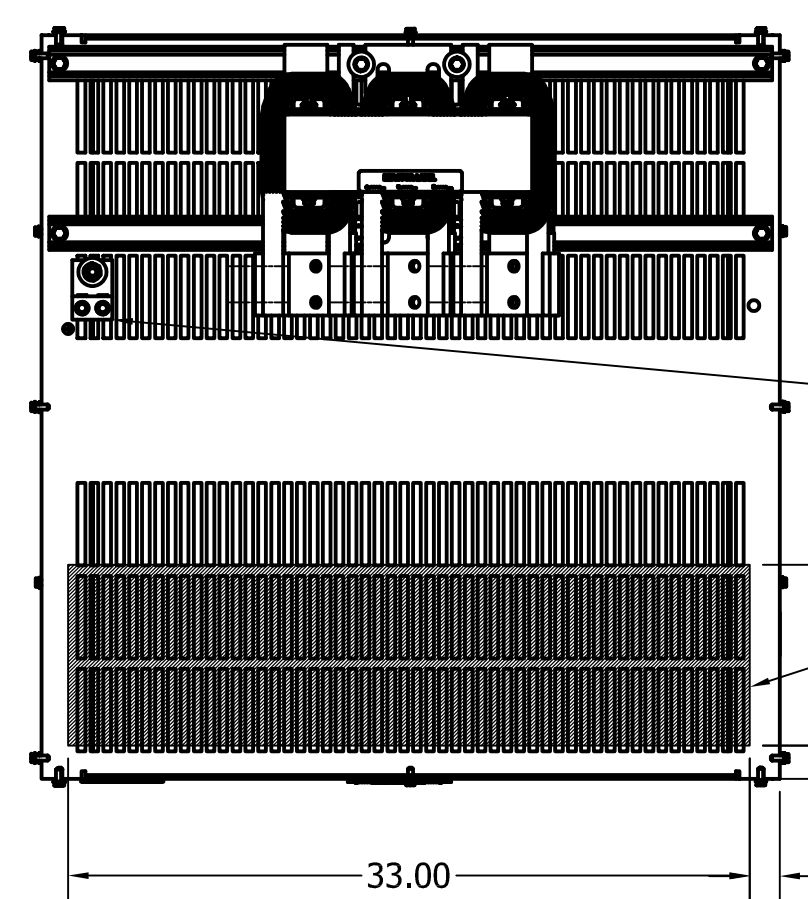
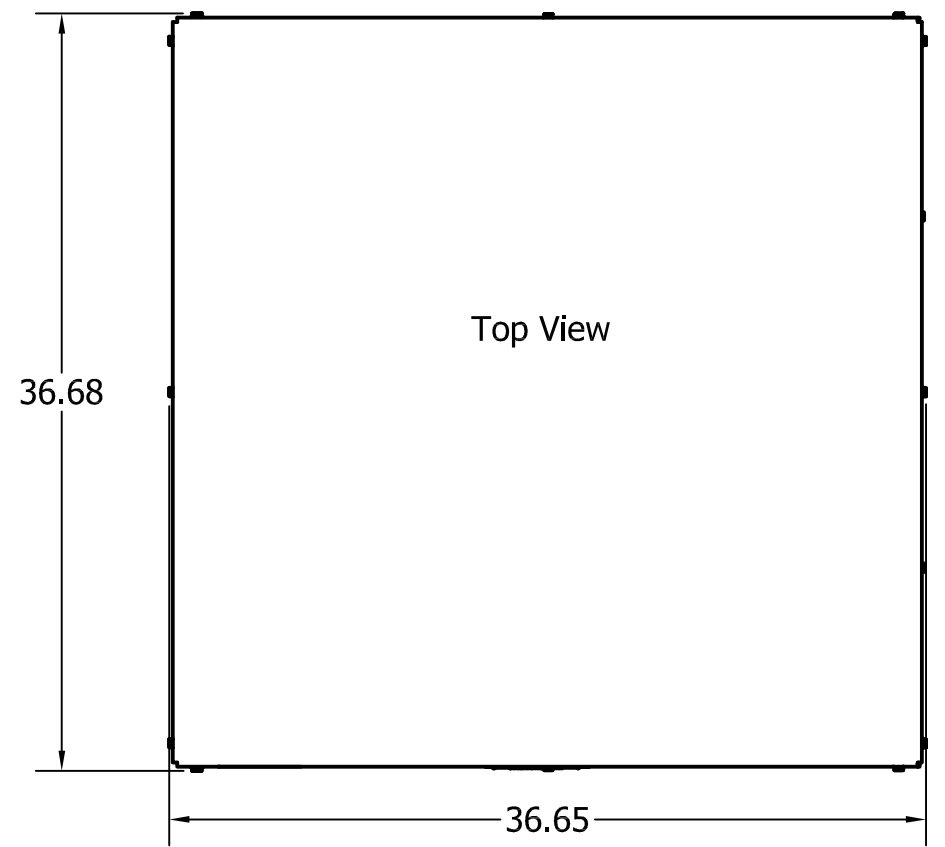

Ground Lug.
See IOM Manual, Part# 30895
Table 2S350, Wire Size And Torque.

Suggested Customer Wire Entrance
Bottom Of Enclosure.
See Note: 8
(Non Removeable Panel)

Suggested Customer Entrance
Either Side Of Enclosure.
See Note: 8
(Non Removeable Panel)

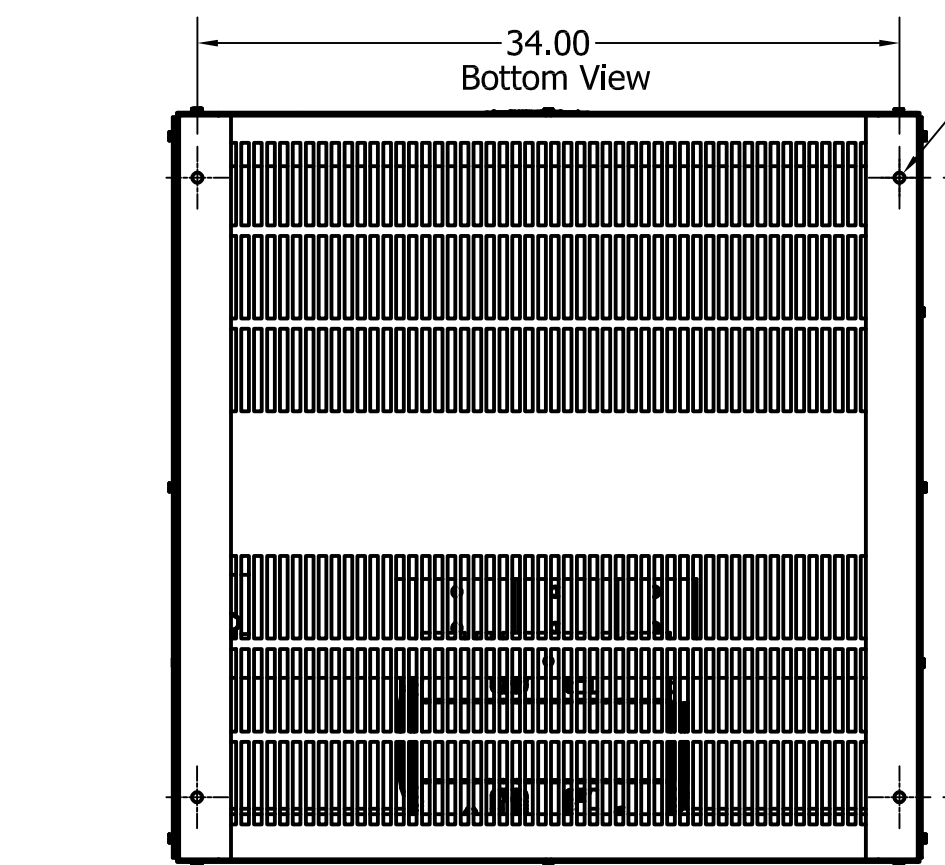
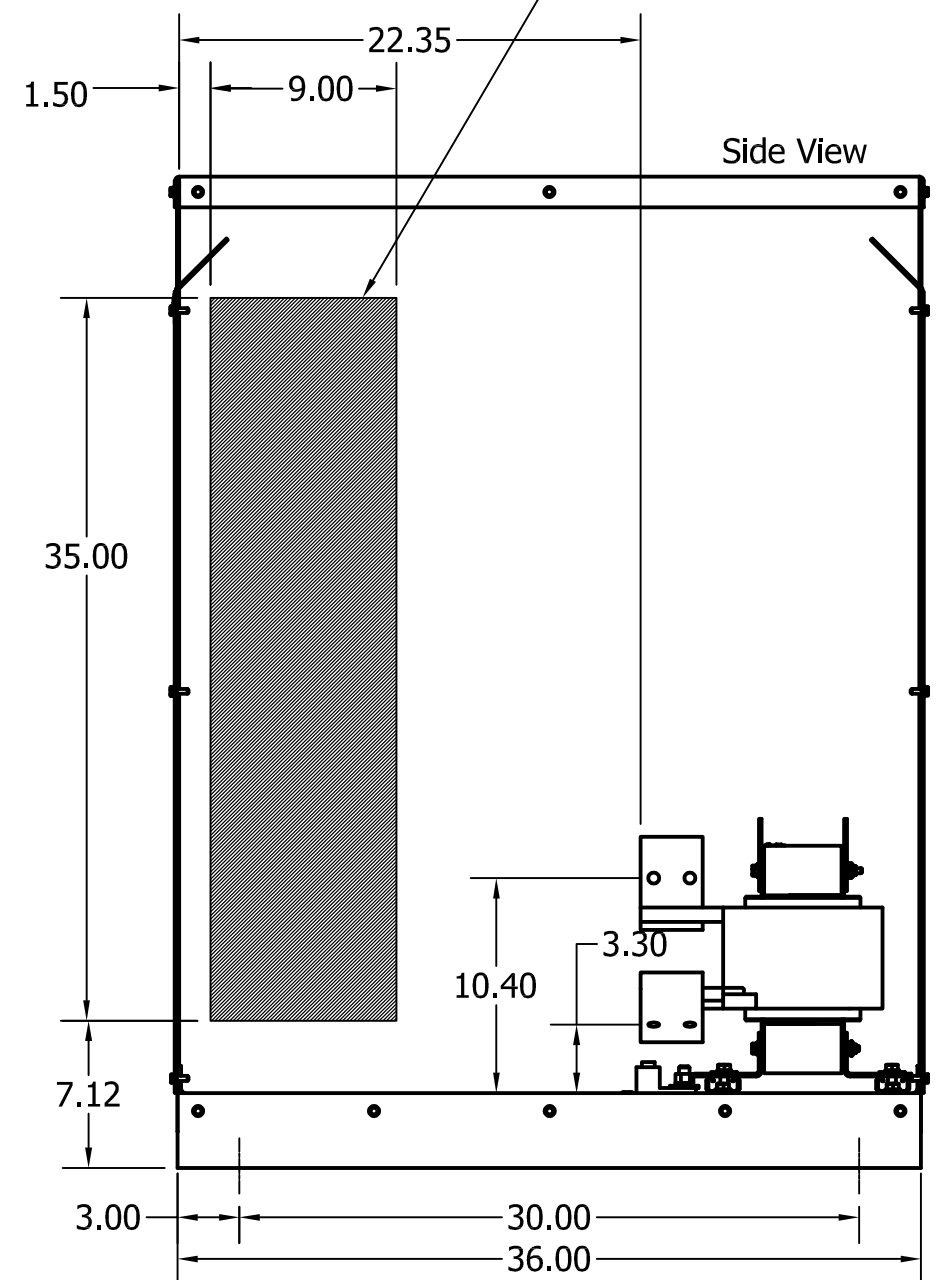
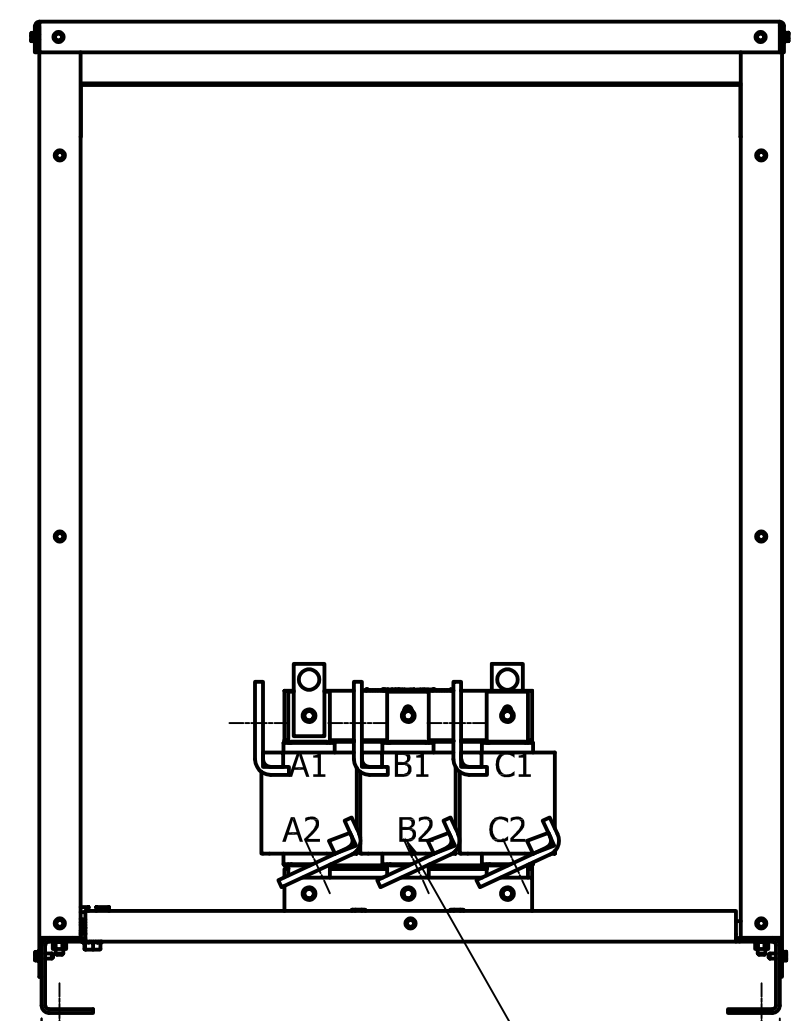
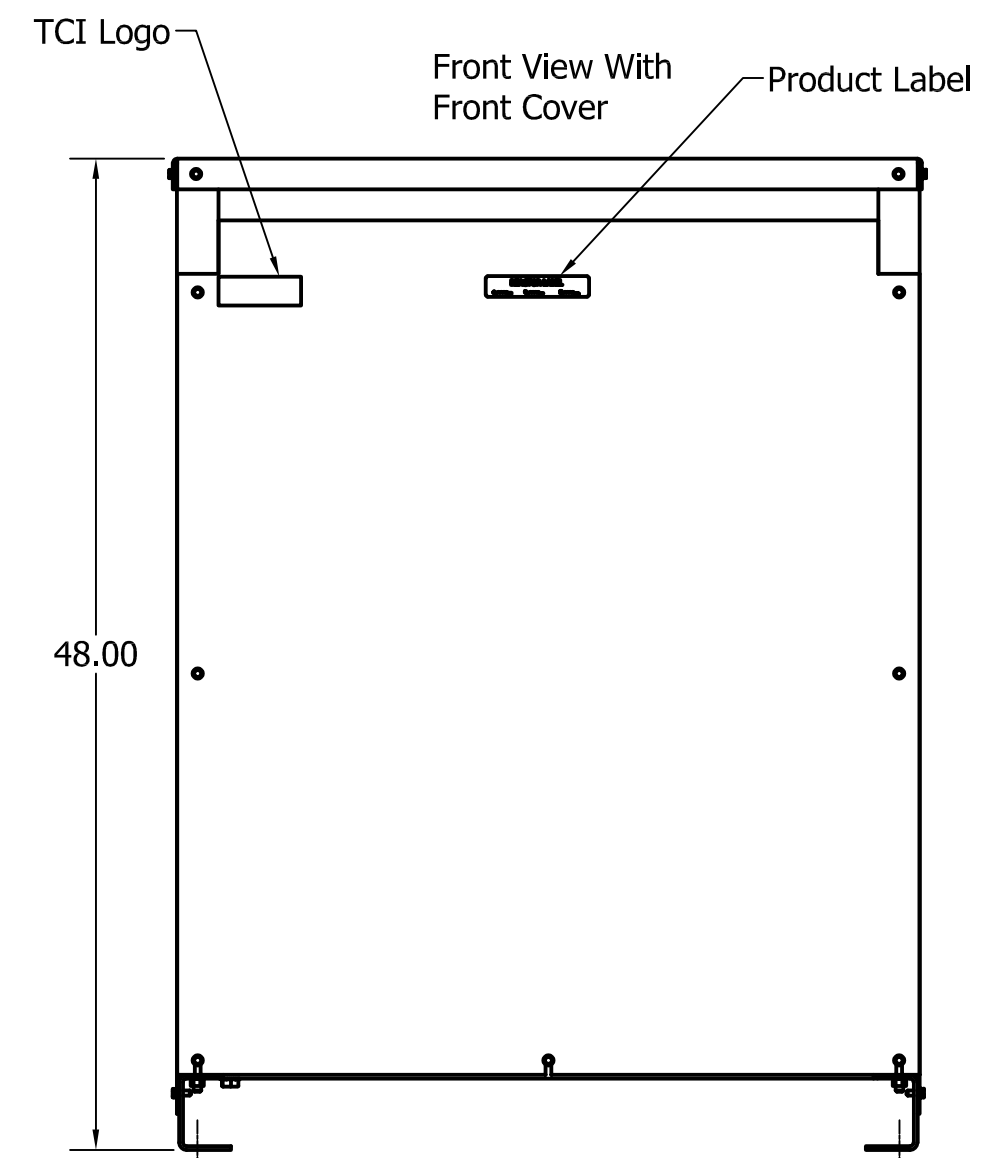

0.50 Dia Mounting Holes
4 Places.

(Customer Connections)
Markings On Coils
For Reference Only.

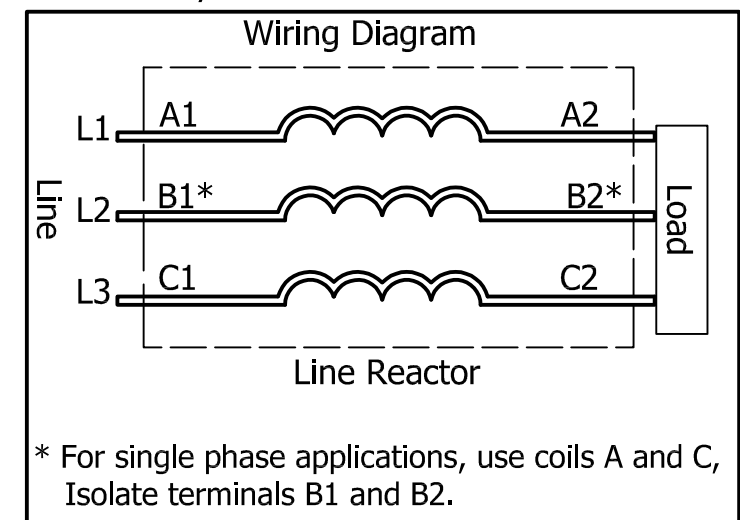

TCI (800) 824-8282 transcoil.com

TCI, LLC
Germantown, WI, USA.
transcoil.com
800-824-8282

KDRUL Drive Reactor
KDR - Motor Amps -
3PH, 50/60Hz, -V Rated, 600V Max, -A Max
40C Amb Max, 155C Min, RoHS
Manual #30895 LUG KIT #SLK-

UL LISTED CE

DATE CODE

- Notes:
1. KDR Lug Kits sold separately. Contact TCI.
 2. For KDRUL Version With Terminal Lugs Attached, See Sheet 8
 3. UL file number: cULus Listed File E116124.
 4. KDR Drive Reactors Comply With The Thermal and Altitude Standards Set Forth by NEMA ST20-1992.
 5. KDR IOM Manual Part Number 30895
 6. NEC Current For 208/240 Volts, Horsepower Based On 208 Volts.
 7. Material(s) Shall be RoHS Compliant
 8. Customer Is Responsible For Installation To Meet All National And Local Electrical Codes.

TCI, LLC CLAIMS PROPRIETARY RIGHTS IN THE MATERIAL HEREIN DISCLOSED. IT IS SUPPLIED WITHOUT PREJUDICE TO ANY PATENT RIGHTS OF TCI AND MAY NOT BE REPRODUCED OR USED TO MANUFACTURE ANYTHING SHOWN THEREIN WITHOUT WRITTEN PERMISSION FROM TCI.

TOLERANCES (EXCEPT AS NOTED)			
DECIMAL			
.XX	± .25		
.XXX	± .10		
FRACTIONAL			
A	As Designed	4/16/18	DSW
ANGULAR			
± 1°			
NO	REVISION	DATE	BY

TCI W132 N10611 Grant Drive
Germantown, WI 53022

KDR S Frame, Copper Bus, Enclosed
Type 1, Reactor Drawing

DRN BY: DSW DATE: 4/16/18 SIZE: 107615DG

SCALE: 1/10 APRVD: C

SHT. 7 OF 8