

480 Rated Voltage, 600 Max Voltage, High Z, Impedance.								
Part Number	Horsepower (HP)	Motor Amps (A)	Maximum Amps (A)	Inductance (uH)	Weight (LBS)	Losses (W)	Available Lug Kit	Terminal Hole Size (Inches)
KDRS1H	600	720	750	43.4	272	1246	SLK15	0.53

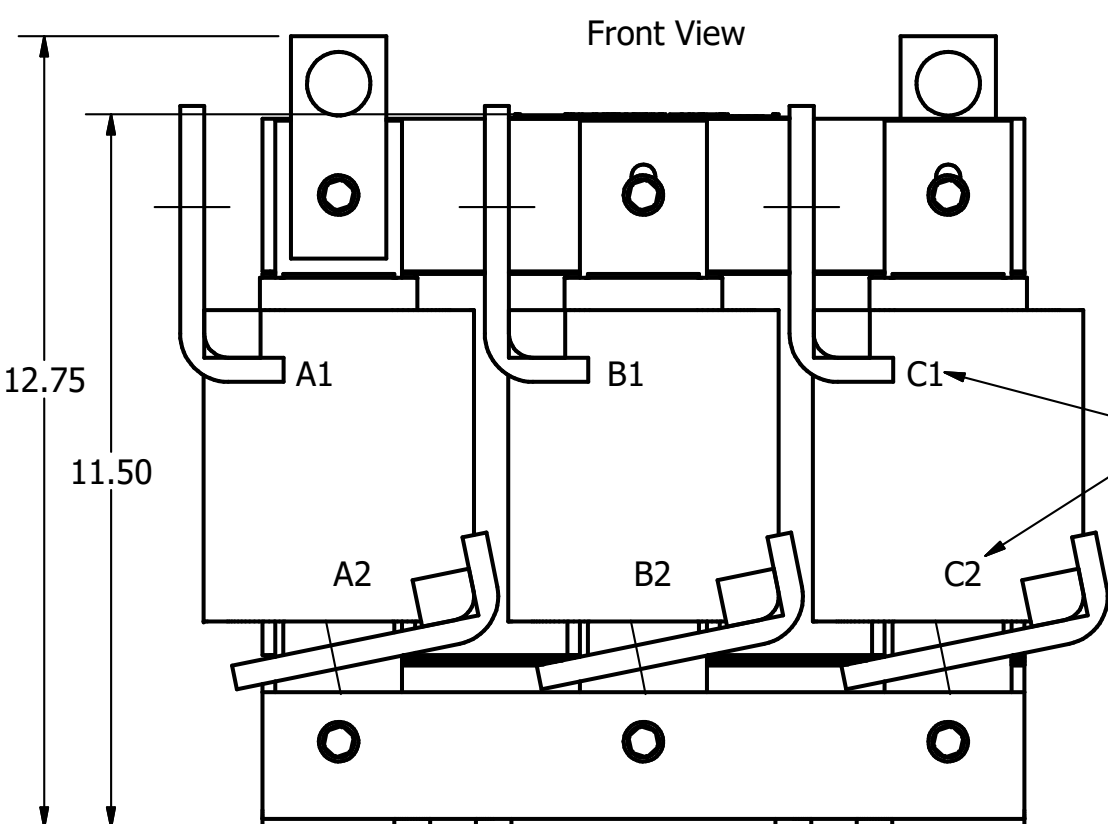

(Customer Connections) Markings On Coils For Reference Only.

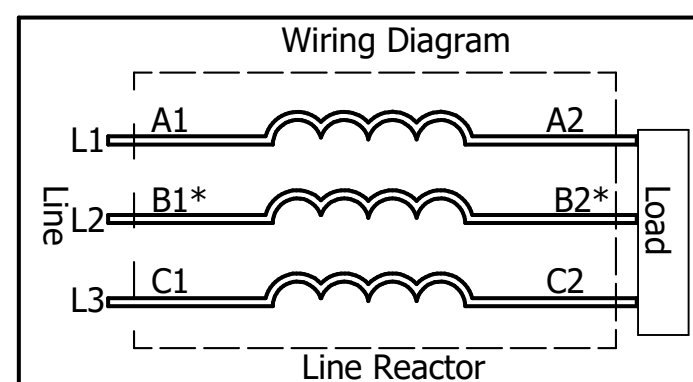
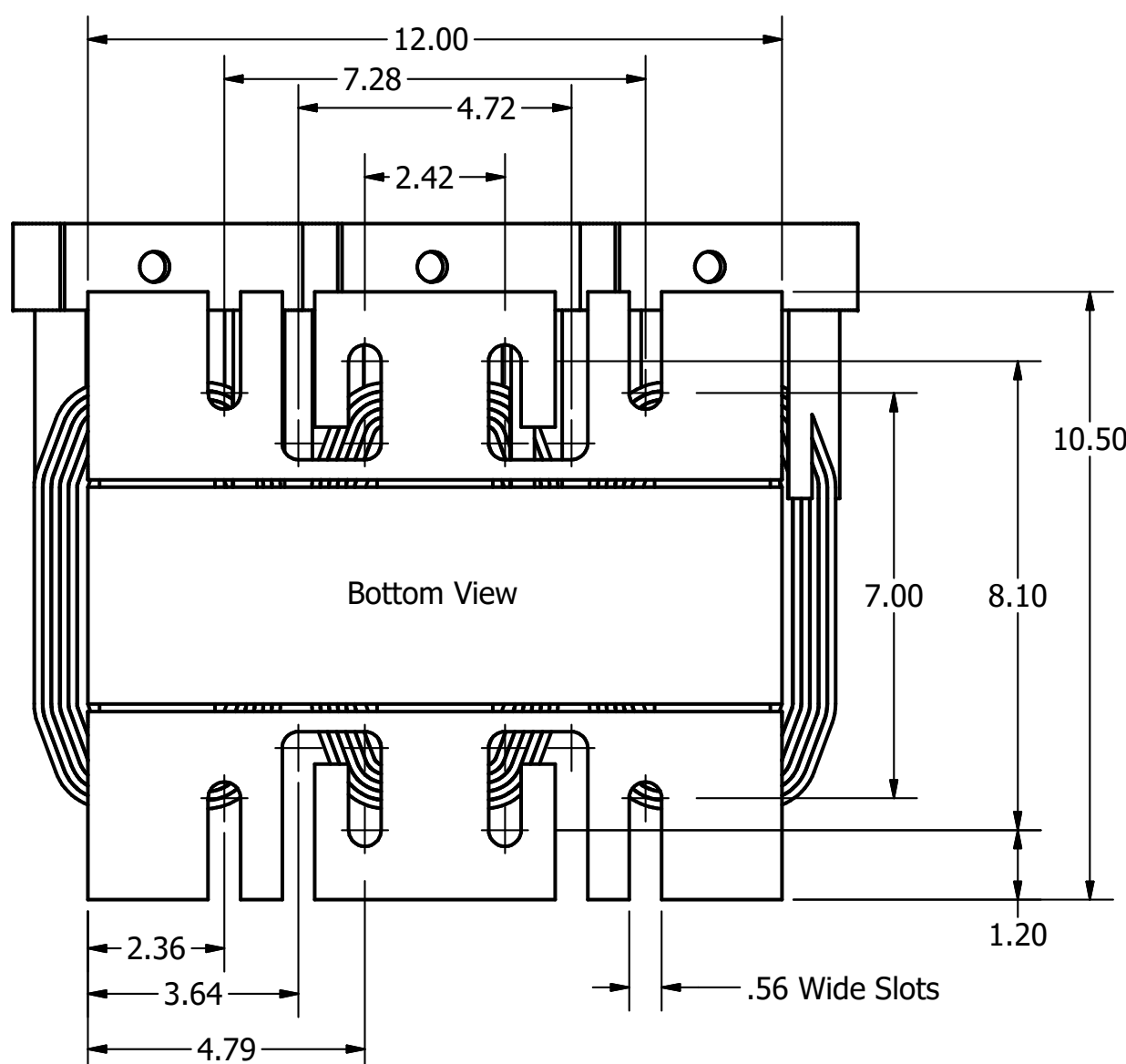
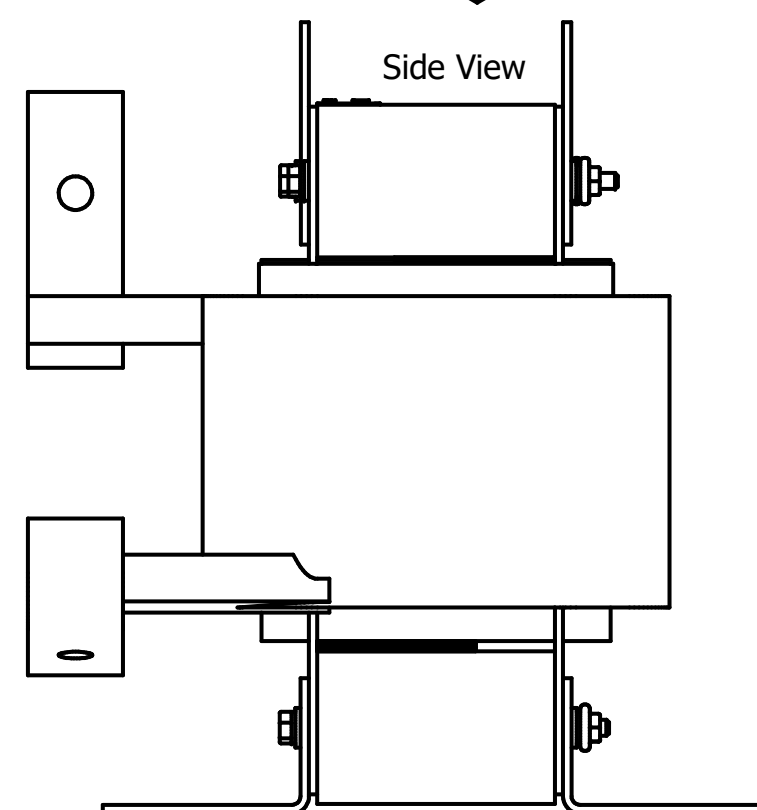

* For single phase applications, use coils A and C, Isolate terminals B1 and B2.

TCI (800) 824-8282 transcoll.com

TCI, LLC
Germantown, WI, USA.
transcoll.com
800-824-8282

KDRUL Drive Reactor
KDR- Motor Amps —
3PH, 50/60Hz, —V Rated, 600V Max, —A Max
40C Amb Max, 155C Rise, RoHS
Manual #30895 LUG KIT #SLK—

UL LISTED CE
250 CONT. OP. TEMP

DATE CODE

- Notes:
1. KDR Lug Kits sold separately. Contact TCI.
 2. For KDRUL Version With Terminal Lugs Attached, See Sheet 4
 3. UL file number: cULus Listed File E116124.
 4. KDR Drive Reactors Comply With The Thermal and Altitude Standards Set Forth by NEMA ST20-1992.
 5. KDR IOM Manual Part Number 30895
 6. NEC Current For 208/240 Volts, Horsepower Based On 208 Volts.
 7. Material(s) Shall be RoHS Compliant
 8. Customer Is Responsible For Installation To Meet All National And Local Electrical Codes.

TCI, LLC CLAIMS PROPRIETARY RIGHTS IN THE MATERIAL HEREIN DISCLOSED. IT IS SUPPLIED WITHOUT PREJUDICE TO ANY PATENT RIGHTS OF TCI AND MAY NOT BE REPRODUCED OR USED TO MANUFACTURE ANYTHING SHOWN THEREIN WITHOUT WRITTEN PERMISSION FROM TCI.

TOLERANCES (EXCEPT AS NOTED)		
DECIMAL		
	XX ± .25	
	.XXX ± .10	
FRACTIONAL		
	± 1/16	
ANGULAR		
	± 1°	
A	Combine Drawings	2/28/18 DSW
NO	REVISION	DATE BY

TCI W132 N10611 Grant Drive
Germantown, WI 53022

KDR S Frame, Copper Bus
Reactor Drawing

DRN BY: DSW DATE: 2/28/18 107538DG
SCALE: 1/3.2 APRVD: SIZE: C
SHT.3 OF 8