

Datasheet - T4V7H 336-11z



Position switch / 336 thermoplastic enclosure - DIN EN 50041 with Actuator / 336 Roller lever
7H

Preferred typ



• only for positioning tasks

- Design to EN 50041
- Thermoplastic enclosure
- Lever angle adjustable in 10° steps
- Double-insulated
- Good resistance to oil and petroleum spirit
- Wide range of alternative actuators
- Actuator heads can be repositioned by 4 x 90°
- 1 Cable entry M 20 x 1.5

(Minor differences between the printed image and the original product may exist!)

Ordering details

Product type description	T4V7H 336-11Z
Article number	101168153
EAN code	4030661220994
eCl@ss	27-27-26-01

Approval

Approval

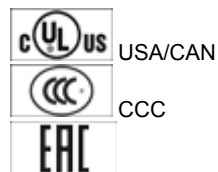

Classification

Standards	EN ISO 13849-1
B _{10d} Normally-closed contact (NC)	20.000.000
Mission time notice	20 Years
	$MTTF_d = \frac{B_{10d}}{0,1 \times n_{op}}$
	$n_{op} = \frac{d_{op} \times h_{op} \times 3600 \text{ s/h}}{t_{cycle}}$

Global Properties

Product name	336 Rollenschwenkhebel 7H
Standards	EN 60947-5-1, BG-GS-ET-15
Compliance with the Directives (Y/N) 	Yes
Suitable for safety functions (Y/N)	No
Materials	
- Material of the housings	Plastic, glass-fibre reinforced thermoplastic, self-extinguishing
- Lever material	Metal film
- Roller material	Plastic
- Material of the contacts	Silver
Housing coating	None
Housing construction form	Norm construction design
Weight	165 g

Mechanical data

Design of electrical connection	Screw connection
Cable section	
- Min. Cable section	0,75 mm ²
- Max. Cable section	2.5 mm ²
Mechanical life	30.000.000 operations
Switching frequency	max. 5000 /h
notice	All indications about the cable section are including the conductor ferrules.
Design of actuating element	Roller lever
actuating torque	min. 31 Ncm
Bounce duration	< 2 ms
Switchover time	in accordance with actuating speed
Actuating speed with actuating angle 30° to switch axis	
- Min. Actuating speed	
- Max. Actuating speed	2.5 m/s

Ambient conditions

Ambient temperature	
- Min. environmental temperature	-30 °C
- Max. environmental temperature	+80 °C
Protection class	IP67

Electrical data

Design of control element	Normally open contact (NO), Opener (NC)
Switching principle	Creep circuit element
Number of auxiliary contacts	1 piece
Number of safety contacts	1 piece
Rated impulse withstand voltage U_{imp}	6 kV
Rated insulation voltage U_i	500 V
Thermal test current I_{the}	10 A
Utilisation category	AC-15: 230 V / 4 A, DC-13: 24 V / 4 A
Required rated short-circuit current	1000 A
Max. fuse rating	6 A gG D-fuse

Dimensions

Dimensions of the sensor

- Width of sensor	40.5 mm
- Height of sensor	173.5 mm
- Length of sensor	57 mm

Diagram

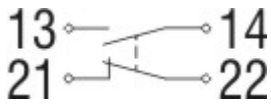

Note Diagram

- positive break NC contact
- active
- no active
- Normally-open contact
- Normally-closed contact

Switch travel diagram

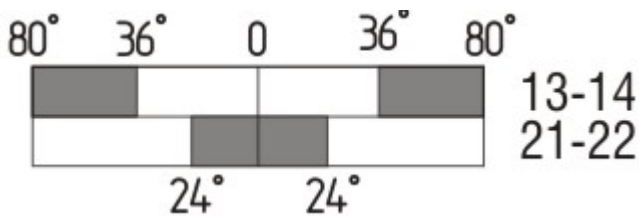

Notes Switch travel diagram

- Contact closed
- Contact open
- Setting range
- Break point
- Positive opening sequence/- angle
- VS** adjustable range of NO contact
- VÖ** adjustable range of NC contact
- N** after travel

Ordering suffix

The applicable ordering suffix is added at the end of the part number of the safety switch.

Order example: T4V7H 336-11z-NPT

...NPT

Cable entry NPT 1/2"

...1637

0,3 µm gold-plated contacts

...ST

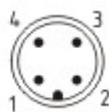
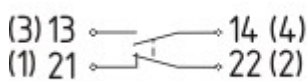

M12 connector with A-coding
 Rated impulse withstand voltage U_{imp} : 4 kV
 Rated insulation voltage U_i : 250 V
 Rated operating voltage U_e : 230 V
 Operating current I_e : 4 A

M12 connector with B-coding
 Rated impulse withstand voltage U_{imp} : 4 kV
 Rated insulation voltage U_i : 250 V

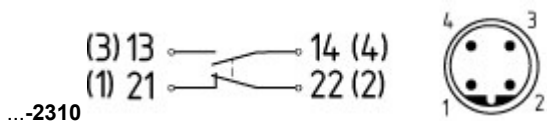

Rated operating voltage U_e : 230 V
 Operating current I_e : 4 A

Ordering code

(1)(2) 336-(3)Z(4)-(5)-(6)-(7)

(1)

Z Snap action

T Slow action

(2)

S Plunger S

R Roller plunger R

H Roller lever H

10H Rod lever 10H

7H Roller lever 7H

1K Offset roller lever 1K

3K Angle roller lever 3K

(3)

11 1 Normally open contact (NO) / 1 Opener (NC)

02 2 Opener (NC)

20 2 Normally open contact (NO), (Switch with 2 NO contacts are not for security tasks)

01/01 1 Opener (NC) left / 1 Opener (NC) right

(4)

H Slow action with staggered contacts

UE Slow action with overlapping contacts

(5)

without Cable entry M20

NPT cable entry NPT 1/2"

ST M12 connector with A-coding

ST-2310 M12 connector with B-coding

(6)

2138 Roller lever 7H for Position switches with safety function

(7)

1637 gold-plated contacts

Documents

Operating instructions and Declaration of conformity (de) 318 kB, 18.03.2016

Code: mrl_zt332-335-336-355_de

Operating instructions and Declaration of conformity (it) 308 kB, 04.04.2013

Code: mrl_zt332-335-336-355_it

Operating instructions and Declaration of conformity (fr) 325 kB, 04.04.2013

Code: mrl_zt332-335-336-355_fr

Operating instructions and Declaration of conformity (nl) 321 kB, 04.04.2013

Code: mrl_zt332-335-336-355_nl

Operating instructions and Declaration of conformity (jp) 1 MB, 22.11.2010

Code: mrl_zt332-335-336-355_jp

Operating instructions and Declaration of conformity (cs) 371 kB, 07.10.2014

Code: mrl_zt332-335-336-355_cs

Operating instructions and Declaration of conformity (pt) 327 kB, 04.04.2013

Code: mrl_zt332-335-336-355_pt

Operating instructions and Declaration of conformity (es) 323 kB, 04.04.2013

Code: mrl_zt332-335-336-355_es

Operating instructions and Declaration of conformity (da) 323 kB, 04.04.2013

Code: mrl_zt332-335-336-355_da

Operating instructions and Declaration of conformity (en) 352 kB, 18.03.2016

Code: mrl_zt332-335-336-355_en

Operating instructions and Declaration of conformity (pl) 372 kB, 06.02.2015

Code: mrl_zt332-335-336-355_pl

CCC certification (en) 187 kB, 03.08.2015

Code: q_347p02

CCC certification (cn) 166 kB, 03.08.2015

Code: q_347p03

EAC certification (ru) 844 kB, 05.10.2015

Code: q_6037p17_ru

Images

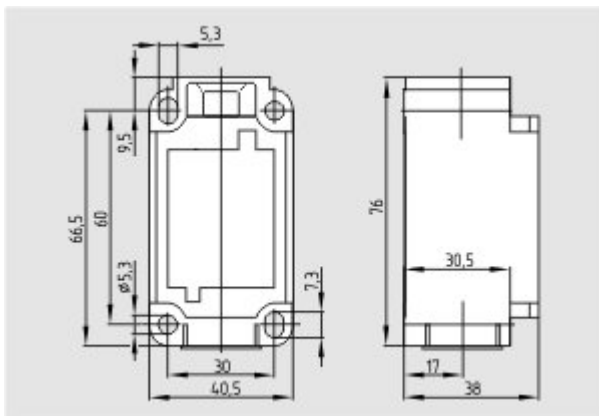

Dimensional drawing (basic component)

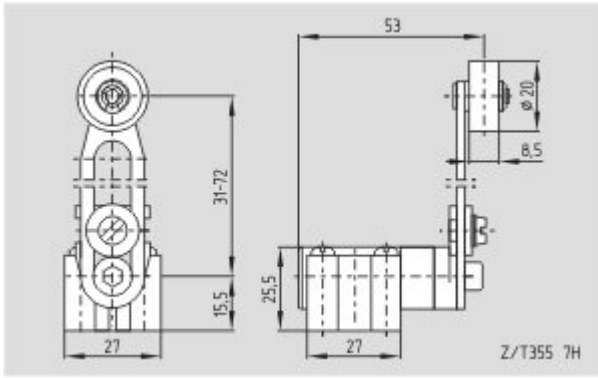

Dimensional drawing (actuator)

K.A. Schmersal GmbH & Co. KG, Möddinghofe 30, D-42279 Wuppertal

The data and values have been checked thoroughly. Technical modifications and errors excepted.

Generiert am 19.07.2016 - 19:49:55h Kasbase 3.2.4.F.64I