



**EN** Operating instructions . . . . .pages 1 to 6  
Original

**Content**

**1 About this document**

1.1 Function . . . . . 1

1.2 Target group: authorised qualified personnel. . . . . 1

1.3 Explanation of the symbols used . . . . . 1

1.4 Appropriate use . . . . . 1

1.5 General safety instructions . . . . . 1

1.6 Warning about misuse . . . . . 1

1.7 Exclusion of liability . . . . . 2

**2 Product description**

2.1 Ordering code . . . . . 2

2.2 Special versions. . . . . 2

2.3 Destination and use . . . . . 2

2.4 Technical data . . . . . 3

2.5 Safety classification . . . . . 3

**3 Mounting**

3.1 Dimensions . . . . . 3

**4 Electrical connection**

4.1 General information for electrical connection. . . . . 3

4.2 Contact variants. . . . . 4

**5 Set-up and maintenance**

5.1 Functional testing. . . . . 4

5.2 Maintenance . . . . . 4

**6 Disassembly and disposal**

6.1 Disassembly. . . . . 4

6.2 Disposal. . . . . 4

**7 EU Declaration of conformity**

**1. About this document**

**1.1 Function**

This operating instructions manual provides all the information you need for the mounting, set-up and commissioning to ensure the safe operation and disassembly of the safety switchgear. The operating instructions must be available in a legible condition and a complete version in the vicinity of the device.

**1.2 Target group: authorised qualified personnel**

All operations described in this operating instructions manual must be carried out by trained specialist personnel, authorised by the plant operator only.

Please make sure that you have read and understood these operating instructions and that you know all applicable legislations regarding occupational safety and accident prevention prior to installation and putting the component into operation.

The machine builder must carefully select the harmonised standards to be complied with as well as other technical specifications for the selection, mounting and integration of the components.

**1.3 Explanation of the symbols used**



**Information, hint, note:**

This symbol is used for identifying useful additional information.



**Caution:** Failure to comply with this warning notice could lead to failures or malfunctions.

**Warning:** Failure to comply with this warning notice could lead to physical injury and/or damage to the machine.

**1.4 Appropriate use**

The products described in these operating instructions are developed to execute safety-related functions as part of an entire plant or machine. It is the responsibility of the manufacturer of a machine or plant to ensure the correct functionality of the entire machinery or plant.

The safety switchgear must be exclusively used in accordance with the versions listed below or for the applications authorised by the manufacturer. Detailed information regarding the range of applications can be found in the chapter "Product description".

**1.5 General safety instructions**

The user must observe the safety instructions in this operating instructions manual, the country-specific installation standards as well as all prevailing safety regulations and accident prevention rules.



Further technical information can be found in the Schmersal catalogues or in the online catalogue on the Internet: [www.schmersal.net](http://www.schmersal.net).

The information contained in this operating instructions manual is provided without liability and is subject to technical modifications.

There are no residual risks, provided that the safety instructions as well as the instructions regarding mounting, commissioning, operation and maintenance are observed.

**1.6 Warning about misuse**



In case of improper use or manipulation of the safety switchgear, personal hazards or damages to machinery or plant components cannot be excluded. The relevant requirements of the standard EN ISO 14119 must be observed.

### 1.7 Exclusion of liability

We shall accept no liability for damages and malfunctions resulting from defective mounting or failure to comply with this operating instructions manual. The manufacturer shall accept no liability for damages resulting from the use of unauthorised spare parts or accessories.

For safety reasons, invasive work on the device as well as arbitrary repairs, conversions and modifications to the device are strictly forbidden; the manufacturer shall accept no liability for damages resulting from such invasive work, arbitrary repairs, conversions and/or modifications to the device.

## 2. Product description

### 2.1 Ordering code

This operating instructions manual applies to the following types:

#### TFH 232-① 1-pedal safety foot switch

No.	Option	Description
①	11UEDR	1 NO / 1 NC
	22UEDR	2 NO / 2 NC

#### T2FH 232-① 2-pedal safety foot switch

No.	Option	Description
①	11UEDR/11UEDR	2 NO / 2 NC
	22UEDR/22UEDR	4 NO / 4 NC
	11/22UEDR	3 NO / 3 NC
	22UEDR/11	3 NO / 3 NC



Only if the information described in this operating instructions manual are realised correctly, the safety function and therefore the compliance with the Machinery Directive is maintained.

### 2.2 Special versions





For special versions, which are not listed in the order code below 2.1, these specifications apply accordingly, provided that they correspond to the standard version.

### 2.3 Destination and use

These robust safety foot switches are particularly suitable for industrial applications. All safety foot switches are mounted with a shield to protect against unintentional operation. When the foot pedal is actuated to as far as the pressure point, the NO contact is closed. If, in case of danger, the pedal is actuated beyond the pressure point, then the positive break NC contact is opened and mechanically latched.

The mechanical latching is realised through a slider and a spring, which are mounted in an enclosure. The reset operation is carried out by means of the blue pushbutton, which is located in the top of the cover. This button pushes on the slider, which is returned to its original position due to this action. The reset button is covered with a rubber cap, which protects the inside of the foot switch enclosure against humidity and soiling.

### Design/Operating principle: overlapping contacts with pressure point and latching (UEDR)

Representation	Condition	Function
 0	Not actuated	No authorised operation
 1	Actuated up to pressure point	Safety release
 0	Pushed-through	No authorised operation
 0 → 0	Unlock	No authorised operation*

\* Switch-on impulse during the unlocking operation must be suppressed by means of measures at control technology level.



For a single-channel connection, a jumper connection must be fitted between the contacts (not included in delivery).



The non-safety-related pedal of the 2-pedal safety foot switch does not have the overlapping and latching functions.



The user must evaluate and design the safety chain in accordance with the relevant standards and the required safety level.



The entire concept of the control system, in which the safety component is integrated, must be validated to the relevant standards.

### 2.4 Technical data

Standards: IEC 60947-5-1,  
DIN VDE 0660-200, BG-GS-ET-15

Material of the enclosure,  
cover and protective shield: aluminium  
Enclosure coating: powder-coated thermoplastic  
Material of the pedal: glass-fibre reinforced thermoplastic

#### Mechanical data

Execution of the electrical connection: screw terminals  
Cable section: 2.5 mm<sup>2</sup>  
(incl. conductor ferrules)  
Cable entry: 1-pedal: 1 x M20 x 1.5;  
2-pedal: 2 x M25 x 1.5  
Mechanical life: > 1,000,000 operations  
Switching frequency: max. 1/s  
Resistance to shock: 30 g / 11 ms  
Resistance to vibration: 10 ... 150 Hz  
(0.35 mm / 5 g)

#### Ambient conditions

Ambient temperature: -25 °C...+60 °C  
Storage and transport temperature: -25 °C...+85 °C  
Relative humidity: 30% ... 95%  
- no condensation  
- no icing

Protection class: IP65  
Overvoltage category: III  
Degree of pollution: 3

#### Electrical data

Execution of the control element: NC contact, NO contact  
Switching principle: Slow action switching contacts  
Rated impulse withstand voltage  $U_{imp}$ : 6 kV  
Rated insulation voltage  $U_i$ : 500 V  
Thermal test current  $I_{the}$ : 10 A  
Utilisation category: DC-13: 24 V / 1 A;  
AC-15: 230 V / 4 A  
Required short-circuit current: 1000 A  
Max. fuse rating: 6 A gG D-fuse  
Dimensions: 1-pedal: 170 x 189 x 274 mm;  
2-pedal: 295 x 189 x 274 mm

 Openings shall be closed by equipment rated for enclosure types: 3, 3R, 3RX, 3S, 3SX, 3X, 5, 4, 4X, 6, 6P, 12 or 13. Use 105°C wires/cables only.

### 2.5 Safety classification

Standards: ISO 13849-1  
 $B_{10D}$  (NC contact): 100,000  
Service life: 20 years

$$MTTF_D = \frac{B_{10D}}{0,1 \times n_{op}} \quad n_{op} = \frac{d_{op} \times h_{op} \times 3600 \text{ s/h}}{t_{cycle}}$$

(Specifications can vary depending on the application-specific parameters  $h_{op}$ ,  $d_{op}$  and  $t_{cycle}$  as well as the load.)

If multiple safety components are wired in series, the Performance Level to ISO 13849-1 will be reduced due to the restricted error detection under certain circumstances.

### 3. Mounting

#### 3.1 Dimensions

All measurements in mm.

##### with 1 foot pedals

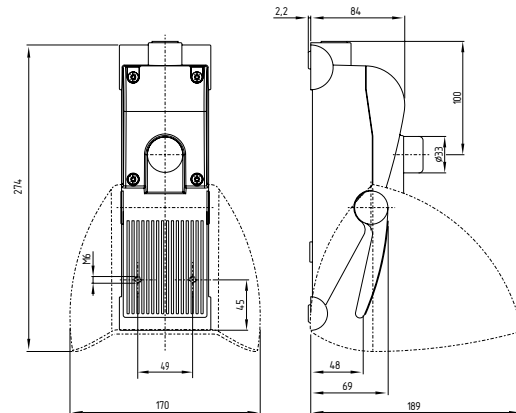

##### with 2 foot pedals

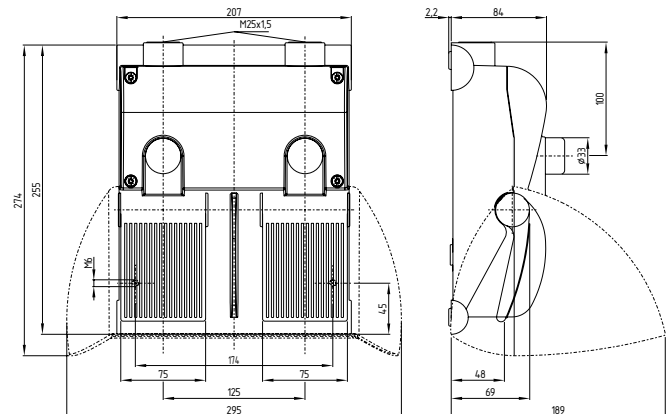

### 4. Electrical connection

#### 4.1 General information for electrical connection



The electrical connection may only be carried out by authorised personnel in a de-energised condition.

The contact labelling can be found in the wiring compartment of the switch. For the cable entry, suitable cable glands with an appropriate degree of protection must be used. The cables must be laid correctly in the wiring compartment of the switch. For foot switches with 1 foot pedal, the M20 x 1.5 cable entry is available, for foot switches with 2 foot pedals, 2x M25 x 1.5. The non-used cable entry must be sealed with blanking plugs. After wiring, the wiring compartment of the switch must definitely be cleaned (e.g. removal of cables residues), considering that foreign bodies can affect the switching behaviour. The tightening torque for the cover screws is min. 1.8 Nm.

### 4.2 Contact variants

The contacts are shown in a non-actuated condition.

#### with 1 foot pedals

1 NO / 1 NC

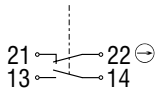

2 NO / 2 NC

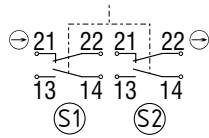

#### with 2 foot pedals

2 NO / 4 NC (T2FH-232-11UEDR/11UEDR)

L

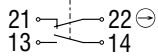

R

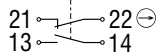

4 NO / 4 NC (T2FH-232-22UEDR/22UEDR)

L

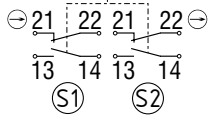

R

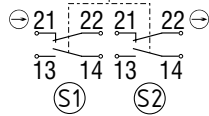

3 NO / 3 NC (T2FH-232-11/22UEDR)

L

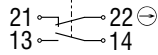

R

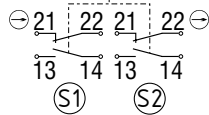

3 NO / 3 NC (T2FH-232-22UEDR/11)

L

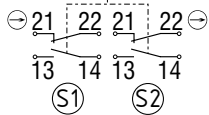

R

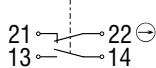

#### Key

- ⊖ positive break NC contact
- L left pedal
- R right pedal

## 5. Set-up and maintenance

### 5.1 Functional testing

The safety function of the safety components must be tested. The following conditions must be previously checked and met:

1. Check the integrity of the cable entry and connections
2. Check the switch enclosure for damage
3. Check the functionality of the switch by actuating the safety foot switch

### 5.2 Maintenance

The safety function (switching) of the safety foot switch must be tested at regular intervals. Possible soiling accumulated below the foot pedal must be removed.

A regular visual inspection and functional test, including the following steps, is recommended:

- Check the switch enclosure for damages
- Check the cable entries and the wire connections

**Damaged or defective components must be replaced.**

## 6. Disassembly and disposal

### 6.1 Disassembly

The safety switchgear must be disassembled in a de-energised condition only.

### 6.2 Disposal

The safety switchgear must be disposed of in an appropriate manner in accordance with the national prescriptions and legislations.

7. EU Declaration of conformity

EU Declaration of conformity



Original  
SCHMERSAL  
Industrial Switchgear (Shanghai) Co., Ltd.  
Cao Ying Road 3336  
201712 Shanghai / Qingpu  
P.R. CHINA  
<http://www.schmersal.com.cn>

We hereby certify that the hereafter described components both in their basic design and construction conform to the applicable European Directives.

**Name of the component:** T.FH 232-..UEDR..

**Type:** See ordering code

**Description of the component:** Foot switch for safety functions

**Relevant Directives:** Machinery Directive 2006/42/EC  
RoHS-Directive 2011/65/EU

**Applied standards:** DIN EN 60947-5-1:2010,  
DIN EN ISO 13849-1:2016

**Person authorized for the compilation of the technical documentation:** Oliver Wacker  
Möddinghofe 30  
42279 Wuppertal

**Place and date of issue:** Shanghai, July 3, 2019

Authorised signature  
Uwe Seeger  
Managing Director

SISS-TFH232-H-EN



The currently valid declaration of conformity can be downloaded from the internet at [www.schmersal.net](http://www.schmersal.net).



**K.A. Schmersal GmbH & Co. KG**  
Möddinghofe 30, 42279 Wuppertal  
Germany  
Telefon: +49 202 6474-0  
Telefax: +49 202 6474-100  
E-Mail: [info@schmersal.com](mailto:info@schmersal.com)  
Internet: [www.schmersal.com](http://www.schmersal.com)

**Production site:**

**SCHMERSAL**

**Industrial Switchgear (Shanghai) Co., Ltd.**

Cao Ying Road 3336  
201712 Shanghai / Qingpu, P.R.CHINA

Phone: +86 21 63758287  
Fax: +86 21 69214398  
E-Mail: [info@schmersal.com.cn](mailto:info@schmersal.com.cn)  
Internet: [www.schmersal.com.cn](http://www.schmersal.com.cn)

施迈赛工业开关制造（上海）有限公司

地址：上海市青浦区漕盈路3336号  
邮编：201712

电话：021 63758287  
传真：021 69214398

网址： [www.schmersal.com.cn](http://www.schmersal.com.cn)