

# SMS 4 / SMS 5 safety mat

Product information



**SCHMERSAL**

## SMS 4 / SMS 5 safety mats

Safety mats are used for the protection of man on machinery and plants with hazardous movements. Typical fields of application are, for instance, the protection of hazardous areas and surfaces on wood-processing machines, scissor lifts or punching presses. The safety mats build a uniplanar safety device, which detects the presence of persons. If a person steps onto the safety mat, the connected safety-monitoring module will immediately stop the hazardous movement.

The safety mats can be connected in line with each other in order to provide for a smooth and fast protection of hazardous areas. To this end, different standard sizes are available. Furthermore, special sizes or special shapes can be realised upon request.

The SMS 4 series is connected to the floor by means of an aluminium profile and special corner sections. As a result of the beveled form of the profile, tripping hazards are avoided. The aluminium profile additionally serves as edge protection, when fork-lift trucks or other floor conveyors drive over the safety mats.

In the SMS 5 series, the polyurethane actuating profile is directly moulded to the active surface of the safety mat.

The safety mats are characterised by their very robust design and high resistance to acids, caustic solutions, oil and gasoline.

In combination with the SRB 301HC/R or SRB 301HC/T safety-monitoring modules, the safety mats meet the requirements of control category 3 to EN 954-1.

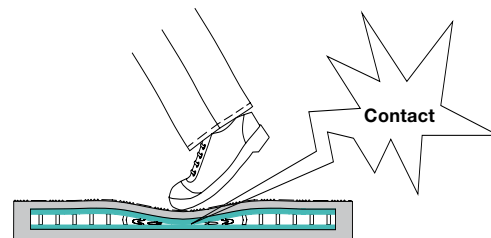
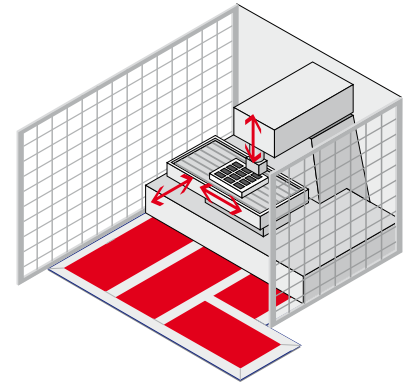

The safety mat consists of two separate current-carrying steel plates. The plates are held apart by insulating strips. Upon actuation of the pressure-sensitive safety mat, an electrical cross-wire short is produced between the steel plates. The connected safety-monitoring module evaluates this signal and stops the hazardous movement.

# Calculation of the safety distance to the danger point

## Safety distance

The proper arrangement of the safety mat with regard to the adjacent hazardous area mainly depends on the after-travel time of the machine and the approaching speed of the operator. The standard EN 999 (Safety of Machinery, Approaching Speed of Body Members) provides a formula to calculate the safety distance for this connection.

## Safety distance

$$S = K \times (T1 + T2) + (1200 - 0.4 H)$$

**S** Minimum safety distance in millimetres, measured from the hazardous area to the detection point, the detection line or the protected field

**K** Constant in millimetres per second, derived from data through the approaching speed of the body or the body member (1600 mm/s)

**H** Distance through the reference plane (e.g. the floor) in millimetres (for safety mats generally 0 mm)

**T1** the maximum response time of the safety device between the triggering of the perceptive element (the safety mat) and the time, at which the safety guard (safety-monitoring module) has switched the output signal to the "OFF" state.

**T2** the response time of the machine, i.e. the time required to shutdown the machine or to eliminate the risk, after the transmission of the output signal of the safety guard

The safety distance therefore generally can be calculated in the following way:

$$S = 1600 \text{ mm/s} \times (T1 + T2) + 1200 \text{ mm}$$

## Example:

The safety distance must be calculated with a response time of 142.5 ms for the machine and a response time of 45 ms for the safety guard. The safety mat is installed at ground level.

$$S = 1600 \text{ mm/s} \times (0.045 \text{ s} + 0.1425 \text{ s}) + 1200 \text{ mm}$$

$$S = 1600 \text{ mm/s} \times (0.1875 \text{ s}) + 1200 \text{ mm}$$

$$S = 300 \text{ mm} + 1200 \text{ mm}$$

$$S = 1500 \text{ mm}$$



# Safety mats

## SMS 4

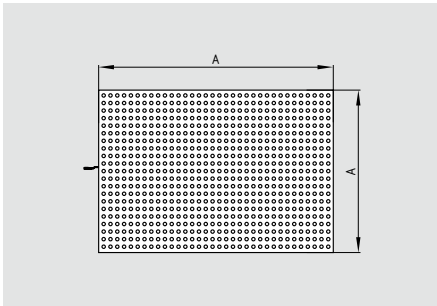

- Certified to EN 1760-1
- Response time max. 25 ms
- Robust design
- High resistance to chemicals
- Slip-free surface
- Cascading possible
- Special sizes and shapes available on request
- No additional terminating resistor required
- Aluminium frame and corner sections available

**Legend:**

A: active surface

**Approvals**



## Ordering details

**SMS 4-①**

No.	Option	Description
①		Active surface
	250-500	250 x 500 mm
	500-500	500 x 500 mm
	500-1000	500 x 1000 mm
	750-1000	750 x 1000 mm
	1000-1000	1000 x 1000 mm
	1000-1500	1000 x 1500 mm

## SMS 5

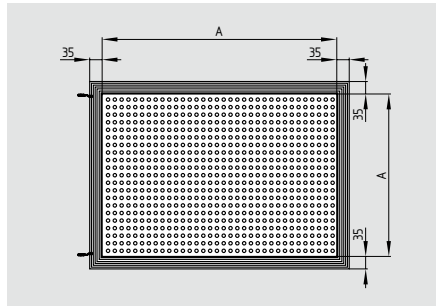
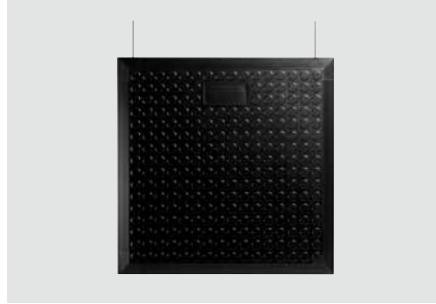

- Certified to EN 1760-1
- Response time max. 25 ms
- Robust design
- High resistance to chemicals
- Slip-free surface
- Cascading possible
- Special sizes and shapes available on request
- No additional terminating resistor required
- With moulded ramp profile

**Legend:**

A: active surface

Total size = A + 2 x 35 mm

**Approvals**



## Ordering details

**SMS 5-①**

No.	Option	Description
①		Active surface
	250-500	250 x 500 mm
	500-500	500 x 500 mm
	500-1000	500 x 1000 mm
	750-1000	750 x 1000 mm
	1000-1000	1000 x 1000 mm
	1000-1500	1000 x 1500 mm

## Technical data

- Standards: EN 1760-1
- Control category: 3 to EN 954-1
- Surface material: polyurethane, black
- Protection class: IP 65 to EN 60529
- Ambient temperature: 0° C ... +60°C
- Fitting height: 14 mm
- Weight: 17 Kg / m<sup>2</sup>
- Actuating force: 150N
- Cable: with round body ø 80mm  
4 x 0.34 mm<sup>2</sup> SMS4  
2 pc. 2 x 0.34 mm<sup>2</sup> SMS 5
- Cable length: 6m
- Response time: ≤ 25 ms
- Mechanical life: >1.5 million operations
- Admissible load: 2000 N / 80 mm ø
- Inactive edge: ≤ 10mm
- Classification:** (In combination with safety monitoring module SRB 301 HC)
- Standards: EN ISO 13849-1; IEC 61508; IEC 60947-5-3
- PL: up to d
- Category: up to 3
- PFH value: 1.0 x 10<sup>-7</sup> /h for max. 52,500 switching cycles/year and max. 60% contact load
- SIL: up to 2 in combination with safety monitoring module
- Mission time: 20 years

## Note

**Chemical resistance:**

- Water : Resistant
- 10% acids: Resistant
- 10% caustic solutions: Resistant
- Oils: Resistant
- Gasoline: Resistant
- Other on request

# SMS 4 safety mats accessories

## System components

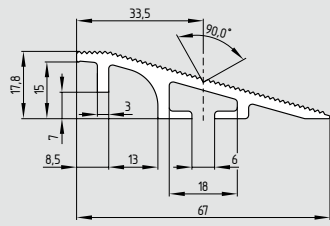

Ramp rail SMS 4-RS-3000

## System components

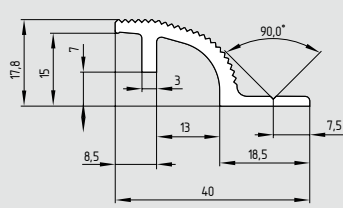

SMS 4-BS-3000 fixing rail

## System components

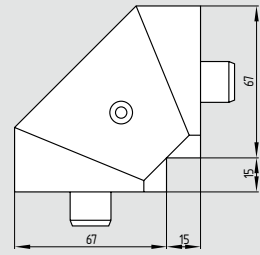

Corner section SMS 4-EV

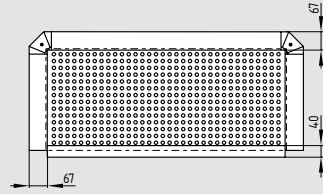

SMS 4

## Ordering details

Ramp rail  
3000 mm long

**SMS 4-RS 3000**

## Ordering details

Fixing rail  
3000 mm long

**SMS 4-BS-3000**

## Ordering details

Corner section (1 pc)

**SMS 4-EV**

## Safety mats

### SRB 301HC



- Safety-monitoring module for safety mats
- 3 enabling contacts
- 1 signalling contact
- Cross-wire detection
- Feedback circuit to monitor external contactors
- Monitored start or automatic start
- LED status indication
- Plug-in terminals

### Technical data

Standards:	IEC/EN 60204-1, IEC/EN 60947-5-1, EN ISO 13849-1; IEC 61508; BG-GS-ET-20	
Start conditions:	automatic or start button (optionally monitored)	
With feedback circuit (Y/N):	yes	
ON delay with reset button:	≤ 50 ms	
Drop-out delay on "emergency stop":	≤ 20 ms	
Drop-out delay on "supply failure":	≤ 100 ms	
Rated operating voltage $U_e$ :	48 ... 240 VAC; 24 VAC/DC	
Frequency range:	50 / 60 Hz	
Fuse rating for the operating voltage:		
230 VAC version:	primary side:	melting fuse, tripping current > 1.0 A;
	secondary side:	internal electronic fuse, tripping current > 0.12 A;
24 VAC/DC version:		internal electronic fuse, tripping current > 0.5 A
Internal electronic fuse (Y/N):	230 VAC version: no 24 VAC/DC version: yes	
Current consumption:	230 VAC version: 1.6 W; 4.2 VA 24 VAC/DC version: 1.4 W; 3.3 VA	
<b>Inputs monitoring:</b>		
	Cross-wire detection:	yes
	Wire breakage detection:	yes
	Earth leakage detection:	yes
	Number of NC contacts:	2
	Number of NO contacts:	0
	Max. total line resistance:	40 Ω
<b>Outputs:</b>		
	Stop category 0:	3
	Stop category 1:	0
	Number of safety contacts:	3
	Number of signalling outputs:	1
	Max. switching capacity of the safety contacts:	250 VAC, 8 A ohmic (inductive with suitable protective circuit)
	Utilisation category to EN 60947-5-1:	AC-15: 230 V / 6 A; DC-13: 24 V / 6 A
	Mechanical life:	10 <sup>7</sup> operations
<b>Ambient conditions:</b>		
	Operating ambient temperature:	- 25°C ... + 60°C
	Storage and transport temperature:	- 25°C ... + 85°C
	Protection class:	enclosure: IP 40, terminals: IP 20, terminal space: IP 54
	Mounting:	snaps onto standard DIN rails to DIN EN 60715
	Connection type:	plug-in type screw terminals
	min. cable section:	0.25 mm <sup>2</sup>
	max. cable section:	2.5 mm <sup>2</sup>
	Weight:	230 VAC version: 340 g; 24 VAC/DC version: 320 g
	Dimensions (height/width/depth):	100 x 45 x 121 mm
<b>Classification:</b>		
	Standards:	EN ISO 13849-1; IEC 61508; IEC 60947-5-3
	PL:	up to e
	Category:	up to 4
	PFH value:	5.0 x 10 <sup>-9</sup> /h for max. 36,500 switching cycles/year and max. 60% contact load
	SIL:	up to 3
	Mission time:	20 years

### Approvals



### Ordering details

#### SRB 301HC/①-②

No.	Option	Description
①	R	Manual start
	T	Automatic start
②	230 V	48 ... 240 VAC
	24 V	24 VAC/DC

## Safety mats

### Note

- Protection of a safety mat
- Start button with edge detection
- Feedback circuit (H) to monitor the external contactors
- Series-wiring of multiple safety mats possible
- Reset button (R)

### Wiring example

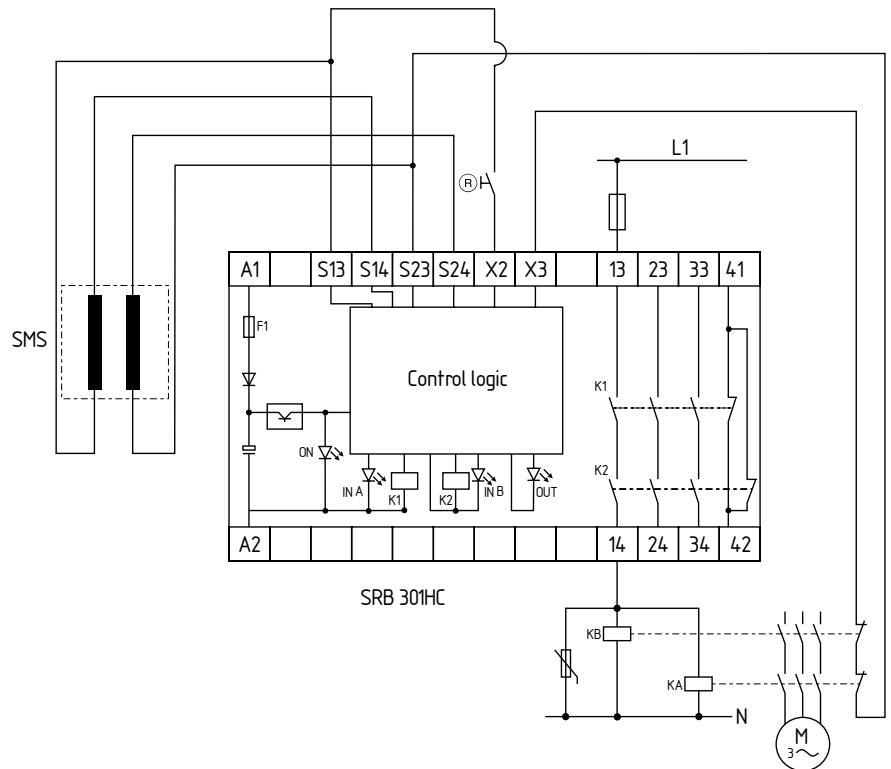

### Note

The wiring example is shown with the safety mat in non-actuated and de-energised condition.

Inductive loads (e.g. contactors, relays, etc.) are to be suppressed by means of a suitable circuit



**K.A. Schmersal GmbH**

Industrielle Sicherheitssysteme

Möddinghofe 30  
D-42279 Wuppertal  
Postfach 24 02 63  
D-42232 Wuppertal

Telefon +49 - (0)2 02 - 64 74 - 0  
Telefax +49 - (0)2 02 - 64 74 - 1 00  
E-Mail [info@schmersal.com](mailto:info@schmersal.com)  
Internet [www.schmersal.com](http://www.schmersal.com)