



**EN** Operating instructions. . . . . pages 1 to 16  
Original

**4 Electrical connection**  
4.1 General information for electrical connection . . . . . 13

**5 Functions and configuration**  
5.1 Programming the slave address . . . . . 13  
5.2 Configuration of the safety monitor . . . . . 13  
5.3 Status signal "safety release" . . . . . 13

**6 Diagnostic**  
6.1 Status information LED . . . . . 13  
6.2 Fault diagnostic . . . . . 14  
6.3 AS-i diagnostics indication . . . . . 14  
6.4 Read-out of the parameter ports . . . . . 14  
6.5 Diagnostic signal periphery error (FID) . . . . . 14

**7 Set-up and maintenance**  
7.1 Check before start-up . . . . . 14  
7.2 Maintenance . . . . . 15  
7.3 Regular check . . . . . 15  
7.4 Half-yearly inspection . . . . . 15  
7.5 Cleaning . . . . . 15

**8 Disassembly and disposal**  
8.1 Disassembly . . . . . 15  
8.2 Disposal . . . . . 15

**9 Appendix**  
9.1 Contact . . . . . 15

**10 EU Declaration of conformity**

**Content**

**1 About this document**  
1.1 Function . . . . . 1  
1.2 Target group: authorised qualified personnel . . . . . 1  
1.3 Explanation of the symbols used . . . . . 1  
1.4 Appropriate use . . . . . 2  
1.5 General safety instructions . . . . . 2  
1.6 Warning about misuse . . . . . 2  
1.7 Exclusion of liability . . . . . 2

**2 Product description**  
2.1 Purpose . . . . . 2  
2.2 Ordering code . . . . . 2  
2.3 Special versions . . . . . 2  
2.4 Scope of delivery and accessories . . . . . 2  
2.4.1 Accessories included in delivery . . . . . 2  
2.4.2 Optional accessory . . . . . 2  
2.5 Technical data . . . . . 3  
2.6 Response time (reaction time) . . . . . 3  
2.7 Safety classification . . . . . 4  
2.8 Functions . . . . . 4  
2.8.1 Fixed blanking SLC440AS . . . . . 4  
2.8.2 Fixed blanking with movable edge region SLC440AS . . . . . 4  
2.8.3 Floating blanking SLC440AS . . . . . 5  
2.8.4 Floating blanking SLG440AS . . . . . 5  
2.9 Self-test . . . . . 6  
2.10 Beam coding A . . . . . 6  
2.11 Parameterisation . . . . . 6

**3 Mounting**  
3.1 General conditions . . . . . 7  
3.2 Protection field and approach . . . . . 7  
3.3 Alignment of the sensors . . . . . 8  
3.4 Set-up tool and set-up mode . . . . . 8  
3.5 Safety distance . . . . . 9  
3.5.1 Minimum distance to reflecting surfaces . . . . . 10  
3.6 Dimensions emitter and receiver . . . . . 10  
3.7 Fixing . . . . . 12

**1. About this document**

**1.1 Function**  
This operating instructions manual provides all the information you need for the mounting, set-up and commissioning to ensure the safe operation and disassembly of the safety switchgear. The operating instructions must be available in a legible condition and a complete version in the vicinity of the device.

**1.2 Target group: authorised qualified personnel**  
All operations described in this operating instructions manual must be carried out by trained specialist personnel, authorised by the plant operator only.

Please make sure that you have read and understood these operating instructions and that you know all applicable legislations regarding occupational safety and accident prevention prior to installation and putting the component into operation.

The machine builder must carefully select the harmonised standards to be complied with as well as other technical specifications for the selection, mounting and integration of the components.

**1.3 Explanation of the symbols used**

 **Information, hint, note:**  
This symbol is used for identifying useful additional information.

 **Caution:** Failure to comply with this warning notice could lead to failures or malfunctions.  
**Warning:** Failure to comply with this warning notice could lead to physical injury and/or damage to the machine.

### 1.4 Appropriate use

The products described in these operating instructions are developed to execute safety-related functions as part of an entire plant or machine. It is the responsibility of the manufacturer of a machine or plant to ensure the correct functionality of the entire machine or plant.

The safety switchgear must be exclusively used in accordance with the versions listed below or for the applications authorised by the manufacturer. Detailed information regarding the range of applications can be found in the chapter "Product description".

### 1.5 General safety instructions

The user must observe the safety instructions in this operating instructions manual, labelled with the caution or warning symbol above, the country-specific installation standards as well as all prevailing safety regulations and accident prevention rules.



Further technical information can be found in the Schmersal catalogues or in the online catalogue on the Internet: [products.schmersal.com](http://products.schmersal.com).

The information contained in this operating instructions manual is provided without liability and is subject to technical modifications. There are no residual risks, provided that the safety instructions as well as the instructions regarding mounting, commissioning, operation and maintenance are observed.

Additional measures could be required to ensure that the system does not present a dangerous breakdown, when other forms of light beams are available in a special application (e.g. use of wireless control devices on cranes, radiation of welding sparks or effects of stroboscopic lights).

### 1.6 Warning about misuse



In case of improper use or manipulation of the safety switchgear, personal hazards or damages to machinery or plant components cannot be excluded. The relevant requirements of the standards ISO 13855 and ISO 13857 must be observed.



Only if the information described in this operating instructions manual are realised correctly, the safety function and therefore the compliance with the Machinery Directive is maintained.

### 1.7 Exclusion of liability

We shall accept no liability for damages and malfunctions resulting from defective mounting or failure to comply with this operating instructions manual. The manufacturer shall accept no liability for damages resulting from the use of unauthorised spare parts or accessories.

For safety reasons, invasive work on the device as well as arbitrary repairs, conversions and modifications to the device are strictly forbidden, the manufacturer shall accept no liability for damages resulting from such invasive work, arbitrary repairs, conversions and/or modifications to the device.

## 2. Product description

### 2.1 Purpose

The SLC/SLG440AS is a non-contact, self-testing safety guard which is used for the protection of hazardous points, hazardous areas and machine accesses. If one or more light beams are interrupted, the hazardous movement must be stopped.



The user must evaluate and design the safety chain in accordance with the relevant standards and the required safety level.



The entire concept of the control system, in which the safety component is integrated, must be validated to the relevant standards.

An AS-Interface Safety at Work component functions on the basis of an individual code generator (8 x 4 bit). This safety code is cyclically transmitted over the AS-i network and monitored by a safety monitor.

### 2.2 Ordering code

This operating instructions manual applies to the following types:

#### SLC440AS-ER-①-②-③

No.	Option	Description
①	xxxx	Protection field heights in mm available lengths: 0170, 0250, 0330, 0410, 0490, 0570, 0650, 0730, 0810, 0890, 0970, 1050, 1130, 1210, 1290, 1370, 1450, 1530*, 1610*, 1690*, 1770*
②	14 30	Resolution 14 mm with a range of 0.3 m ... 7 m Resolution 30 mm with a range of 0.3 m ... 10 m
③	A	Option: Beam coding A

\* only for resolution 30 mm

#### SLG440AS-ER-①-②

No.	Option	Description
①	xxxx-xx 0500-02 0800-03 0900-04	Distance between outermost beams: 500 mm, 2-beam 800 mm, 3-beam 900 mm, 4-beam
②	A	Option: Beam coding A

### 2.3 Special versions

For special versions, which are not listed in the order code, these specifications apply accordingly, provided that they correspond to the standard version.

### 2.4 Scope of delivery and accessories

#### 2.4.1 Accessories included in delivery

##### Mounting kit MS-1100

The kit comprises 4 rotating mounting angles and 8 mounting screws for fixing to the end caps.

##### MSD5 spacer

The kit comprises 2 spacers and is included in delivery as of a protection field height of 1050 mm. Mounting recommended in case of vibrations.

#### 2.4.2 Optional accessory

##### Centre support MS-1110

Consisting of 2 steel brackets and 4 spacers

##### MSD4 Vibration damper

Kit consisting of: 8 vibration dampers 15 x 20 mm, 8 M5 cylinder head screws with hexagon socket, 8 spring washers. Mounting using MS-1100. The MSD4 vibration damper kit is recommend to be used for damping vibrations and oscillations on the SLC/SLG. For applications with higher mechanical stresses, e.g. presses, punching machines, we recommend the MSD4 kit. In this way, the availability of the SLC/SLG is increased.

##### Test rod PLS

The test rod is used for testing the protection field.

##### Adapter cable for parameter setting

Article No.	Designation	Description	Length
1030005659	KA-0975	Y-distributor with command device	1 m

### 2.5 Technical data

Standards:	EN 61496-1, EN 61496-2, EN 62026-2, ISO 13849-1, EN 62061
Working principle:	optoelectronically
Material of the enclosure:	Aluminium
Execution of the electrical connection:	M12 connector,
- receiver:	5 poles
- emitter:	4 poles
Protection field heights:	
- SLC440AS:	
- with resolution 14 mm:	170 mm ... 1450 mm
- with resolution 30 mm:	170 mm ... 1770 mm
- SLG440AS:	500 mm, 800 mm, 900 mm
Detection ability for test bodies:	
- SLC440AS:	14 mm and 30 mm
- SLG440AS:	2 beams with resolution 500 mm <sup>1)</sup> 3 beams with resolution 400 mm <sup>1)</sup> 4 beams with resolution 300 mm <sup>1)</sup>
<sup>1)</sup> Resolution = beam distance + beam diameter 10 mm	
Range of the protection field:	
- SLC440AS:	
- with resolution 14 mm:	0.3 ... 7.0 m
- with resolution 30 mm:	0.3 ... 10.0 m
- SLG440AS:	0.3 ... 12.0 m
Reaction time:	
- SLC440AS:	
- Default beam coding:	1 - 48 L = 13 ms, 49 - 144 L = 23 ms
- Beam coding A:	1 - 48 L = 18 ms, 49 - 144 L = 30 ms
- SLG440AS:	
- Default beam coding:	2 - 4 beams = 13 ms
- Beam coding A:	2 - 4 beams = 18 ms
<b>Emitter, infrared emitted radiation</b>	
Wavelength of the infrared radiation:	880 nm
- to DIN EN 12198-1:	Category 0
- to DIN EN 62471:	free group
<b>Ambient conditions</b>	
Ambient temperature:	- 10°C ... +50°C
Storage and transport temperature:	- 25°C ... +70°C
Resistance to shock:	10 g / 16 ms, IEC 60068-2-27
Resistance to vibration: 10 ... 55 Hz, amplitude 0.35 mm, IEC 60068-2-6	
Protection class:	IP67, IEC 60529
Protection class:	III
Insulation values to IEC 60664-1:	
- Rated impulse withstand voltage U <sub>imp</sub> :	0.8 kV
- Rated insulation voltage U <sub>i</sub> :	32 VDC
- Overvoltage category:	III
- Degree of pollution:	2
<b>Electrical data - AS-Interface</b>	
AS-i supply voltage:	18.0 ... 31.6 VDC, protection against polarity reversal
AS-i power consumption - receiver:	≤ 50 mA
AS-i device insulation:	internal short-circuit proof
AS-i specification:	
- Version:	V 3.0
- Profile:	S-0.B.F.E
AS-i inputs:	
- Channel 1:	Data bits DI 0/DI 1 = dynamic code transmission
- Channel 2:	Data bits DI 2/DI 3 = dynamic code transmission Databits condition static 0 or dynamic code transmission
AS-i Outputs:	
- DO 0 ... DO 3:	no function
AS-i parameter bits:	
- P0:	no function
- P1:	poor beam quality
- P2:	no function
- P3:	device error (FID)
Parameter request:	default value parameter request "1111" (0xF)

AS-i Input module address: 0

- preset to address 0, can be changed through AS-interface bus master or hand-held programming device

### Electrical data - auxiliary voltage (Aux)

Supply voltage U <sub>B</sub> :	24 VDC (-15 % / +10 %), protection against polarity reversal, stabilised PELV units
Power consumption receiver:	≤ 150 mA
Power consumption emitter:	≤ 75 mA
Device fuse rating:	≤ 4 A (when used to UL 508)

### Parameter input (receiver, pin 5)

Input voltage HIGH (active):	11 ... 30 V
Input voltage LOW (inactive):	0 ... 2.0 V
Input current HIGH:	3 ... 10 mA
Input current LOW:	0 ... 3 mA
Functions:	beam blanking fixed and floating, set-up mode

### LED status indication and 7-segment display

- Emitter:	send, status
- Receiver:	OSSD status, signal receipt, blanking, information

### AS-i LED in end cap receiver connection side

green/red LED (AS-i duo LED):	Supply voltage/ communication error / slave address = 0 / periphery error detected
-------------------------------	---

### 2.6 Response time (reaction time)

The response time depends on the height of the protection field, the resolution, the number of light beams and the beam coding A.

#### SLC440AS Resolution 14 mm

Protected height [mm]	Beams [lines]	Response time [ms]	Response time Beam coding A [ms]	Weight [kg]
170	16	13	18	0.4
250	24	13	18	0.5
330	32	13	18	0.6
410	40	13	18	0.8
490	48	13	18	0.9
570	56	23	30	1.0
650	64	23	30	1.1
730	72	23	30	1.2
810	80	23	30	1.4
890	88	23	30	1.5
970	96	23	30	1.6
1050	104	23	30	1.7
1130	112	23	30	1.8
1210	120	23	30	2.0
1290	128	23	30	2.1
1370	136	23	30	2.2
1450	144	23	30	2.3

SLC440AS Resolution 30 mm

Protected height [mm]	Beams [lines]	Response time [ms]	Response time Beam coding A [ms]	Weight [kg]
170	8	13	18	0.4
250	12	13	18	0.5
330	16	13	18	0.6
410	20	13	18	0.8
490	24	13	18	0.9
570	28	13	18	1.0
650	32	13	18	1.1
730	36	13	18	1.2
810	40	13	18	1.4
890	44	13	18	1.5
970	48	13	18	1.6
1050	52	23	30	1.7
1130	56	23	30	1.8
1210	60	23	30	2.0
1290	64	23	30	2.1
1370	68	23	30	2.2
1450	72	23	30	2.3
1530	76	23	30	2.4
1610	80	23	30	2.6
1690	84	23	30	2.7
1770	88	23	30	2.8

SLG440AS

Beams [Number]	Beam distance [mm]	Response time [ms]	Response time Beam coding A [ms]	Weight [kg]
2	500	13	18	0.90
3	400	13	18	1.35
4	300	13	18	1.50

 The total reaction time of the safety guard consists of the reaction times of the BWS, the maximum reaction time of the AS-i safety system and the reaction time of the actuators.

**Reaction time AS-i safety system: ≤ 40 ms**  
(AS-i slave + AS-i transmission + AS-i safety monitor)

2.7 Safety classification

Standards:	ISO 13849-1, EN 62061
PL:	e
Control Category:	4
PFH value:	≤ 5.17 x 10 <sup>-9</sup> / h
SIL:	suitable for SIL 3 applications
Mission time:	20 years

2.8 Functions

The system consists of a receiver and an emitter. For the described functions, no further switching elements are required. The diagnostics and the function selection are realised by means of the parameter adapter (KA-0975), refer to chapter "Parameter setting".

 The BWS is set to „Automatic protection mode“. A possible restart interlock must be configured in the AS-i safety monitor.

The SLC has the following features:

- Blanking of fixed protection field areas
- Blanking of fixed protection field areas with movable edge region
- Blanking of movable protection field areas

The SLG has the following features:

- Blanking of movable protection field areas



Systems with alternative beam coding A can be ordered through the type code (refer to type code).

2.8.1 Fixed blanking SLC440AS

The SLC440AS can blank stationary objects in the protection field.

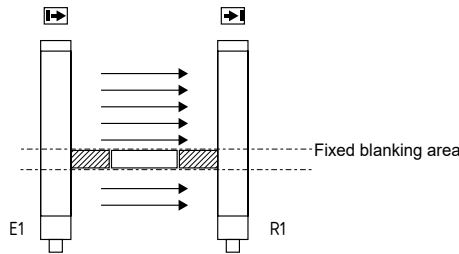
Multiple protection field areas can be blanked. If small changes are made within the fixed blanking area, each time 1 beam can be additionally blanked to increase the tolerance. See chapter Parameter setting - Fixed blanking with movable edge regions (P 2).



**Key**  
 Object in protection field  
 mechanical cover

The range of the fixed blanking can be arbitrarily chosen in the protection field. The first beam line, which realises the optical synchronisation and is located immediately behind the diagnostic window, cannot be blanked.

The area of the fixed blanking must not be modified after the teach-in process. Any change of the area or removal of the object from the protection field will be detected by the system. As a result, the outputs are disabled (locked). This locking can be neutralised by executing a new teach-in process in accordance with the actual beam interruptions.

 The function is activated by means of the parameter setting (P1). If the function is activated, the LED blanking in the diagnostic window of the receiver starts flashing. See chapter Parameter settings.

- 
- The remaining lateral areas must be protected against intrusion by means of mechanical covers.
  - The lateral covers must be fixed with the object.
  - Partial covers are not authorised.
  - After the fixed blanking, the protection field must be tested by means of the test rod.
  - The restart interlock function of the safety light curtain or the machine must be activated.

2.8.2 Fixed blanking with movable edge region SLC440AS

This function can compensate slight position changes of a fixed blanked object with a change of +/- 1 beam. This position change corresponds to an amplitude of approx. +/- 10 mm resolution 14 mm and approx. +/- 20 mm resolution 30 mm upwards and downwards in the protection field.

**Example of beam blanking (object in protection field)**

Beam number	3	4	5	6	7	Status OSSDs
Fixed blanking, beam 4, 5 and 6	○	●	●	●	○	Teach In
Shift 1 beam down	●	●	●	○	○	ok
Shift 1 beam up	○	○	●	●	●	ok
Object only covers 2 beams	○	○	●	●	○	ok
Object only covers 2 beams	○	●	●	○	○	ok
Object with downward edge displacement	●	●	●	●	○	ok
Object with upward edge displacement	○	●	●	●	●	ok
Object displacement exceeds 1 beam	○	○	○	●	●	Error
Object size changed (1 beam)	○	○	●	○	○	Error
Object size changed (5 beams)	●	●	●	●	●	Error

The operating mode is only available, when the parameter setting - fixed blanking with movable edge region is activated (P 2). See chapter Parameter setting.

A combination with only fixed beam blanking (P 1) or additional floating beam blanking (P 3) is not possible.

This blanking changes the physical resolution. The then effective resolution of the SLC440AS can be found in the table in the chapter "Floating blanking" (1 beam).



Perform a new calculation of the safety distance with the effective resolution. Adjust the safety distance in accordance with your calculation.

**2.8.3 Floating blanking SLC440AS**

The SLC440AS safety light curtain can blank movable objects in the protection field.

The SLC440AS can be used for the floating blanking of to 2 beams in the protection field, refer to parameter setting (P 3). A combination of fixed and floating beam blanking (P 1 and P 3) is enabled.

A combination of fixed blanking with movable edge region (P 1) and floating blanking (P 3) is not possible.

**Example:**

**Floating and fixed blanking**

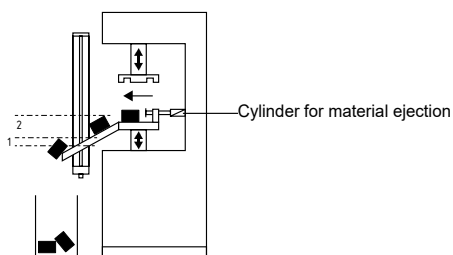

**Legend:**

- 1: Fixed blanking area
- 2: Floating blanking area

The function enables an arbitrary floating blanking of partial areas in the protection field. The first beam, which is located immediately behind the diagnostic window, cannot be blanked.

This function allows for an interruption of the protection height without the outputs being disabled in case of material movement in the protection field, e.g. material ejection or process-controlled material movement. This extension of the object detection increases the resolution. Therefore the physical resolution is changed to an effective resolution. This effective resolution must be used to calculate the safety distance. Use formula (1) to calculate the safety

distance with the effective resolution if a maximum of 2 light beams are blanked; use formula (3) indicated in the "Safety distance" chapter if more than 2 light beams are blanked. The number of light beams to be blanked is limited, see table "Effective resolution".

In a system with a 14 mm physical resolution, the effective resolution is increased to 34 mm in case of a floating blanking of 2 beams (68 mm for a system with a resolution of 30 mm). The effective resolution must be permanently known and well visible on the information label of the receiver.

**Effective resolution**

The effective resolution in case of activated blanking of floating beams can be found in the following table:

Resolution 14 mm		
Blanked beams	Physical resolution	Effective resolution
1	14	24
2	14	34

Resolution 30 mm		
Blanked beams	Physical resolution	Effective resolution
1	30	48
2	30	68



The function is activated in parameter setting mode (P 3). If the function is activated, the LED blanking in the diagnostic window of the receiver starts flashing.



Perform a new calculation of the safety distance with the effective resolution. Adjust the safety distance in accordance with your calculation.



The standard IEC/TS 62046 includes information, which describe possibly required additional measures to prevent a person from reaching a hazard through the blanking areas of a protection field.

**2.8.4 Floating blanking SLG440AS**

The SLG440AS can blank movable objects in the protection field.

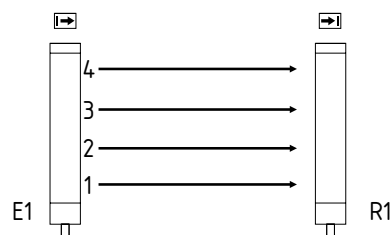

The floating blanking range is authorised for individual beams in case of obstacles, taking the protective function into account.

The function enables an arbitrary floating blanking of partial areas in the protection field. The first beam, which is located immediately behind the diagnostic window, cannot be blanked.

This function allows for an interruption of maximum 1 light beam without the outputs being disabled in case of material movement in the protection field, e.g. ejection of material or process-controlled material movement.

The operating mode is only available, when the parameter setting P 3 is activated. See chapter Parameter setting.



- The variable blanking of one beam is not authorised with the 2-beam SLG440AS!
- The blanking of one beam at the most in the SLG440AS 3-beam version or the SLG440AS 4-beam version is authorised, provided that the protective function is taken into account.
- The restart interlock (manual reset) function of the safety light grid or the machine must be activated.
- The protection field must be checked with a test rod by a qualified person after the configuration.
- The standard IEC/TS 62046 includes information, which describes possibly required additional measures to prevent a person from reaching a hazard through the beam blanking of a protection field.

**2.9 Self-test**

The system performs a complete self-test and safety test within 2 seconds after the operating voltage has been switched on. If the protection field is not interrupted, the system switches to the ON condition (automatic mode). In case of an error, the outputs at the receiver do not switch to the ON state. An error message is emitted in the form of an error code. For more information, refer to chapter Fault diagnosis.

During operation, the system executes a cyclic self-test. Safety-relevant faults are detected within the reaction time and cause the outputs to be switched off and an error code to be emitted.

**2.10 Beam coding A**

For systems where mutual interferences can be expected, emitters and receivers with alternative beam coding must be used. This could be required, when systems are operating in each other's vicinity and a set-up as shown in the image below (no interference) is possible. A receiver with activated beam coding A can distinguish the beams of the emitter with the same beam coding, which are destined to this particular receiver, from foreign beams.

If adjacent systems are operated without beam coding A, the user is at risk.

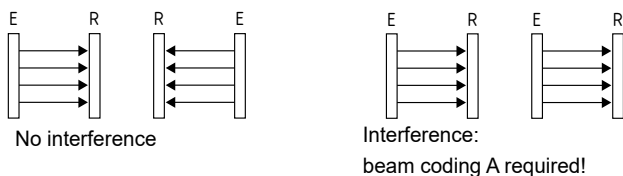

- The beam coding A avoids mutual interference of adjacent systems.
- The beam coding A is permanently shown by the emitter and the receiver by means of flashing LED's (refer to LED status information).
- The beam coding A must be ordered separately for each **sensor** (emitter and receiver).

**2.11 Parameterisation**

The parameter setting of the SLG440AS enables the individual adjustment of the desired functionality to the application.

**Parameter display (7-segment display):**

- A = parameter active
- = parameter not active
- S.** = save the current configuration
- C.** = delete the current configuration, new configuration = factory setting
- n = unavailable (unauthorised setting, refer to Parameter setting information)
- d. = diagnostic/setting mode

**Parameter selection:**

Selection, change and acceptance of the parameters by means of button (2) of the parameter adapter KA-0975 :

- Switch to parameter setting Px briefly press the button 0.1 ... 1.5 sec.
- Change parameter setting Px press button 2.5 ... 6 sec.
- Save **S.** /Factory setting **C.** press button 2.5 ... 6 sec.

**Procedure:**

For the parameter setting, the adapter cable KA-0975 is used. The adapter cable is connected between the connecting cable and the cable connector of the receiver. The parameters are set by means of the command device (pushbutton), as described in the parameter setting.

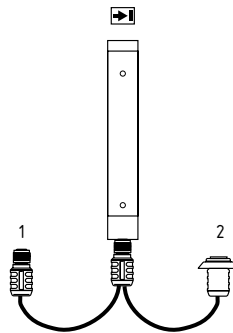

**Key:**

- 1 = Connecting cable Receiver
- 2 = Command device pushbutton for release

- 1) Connect the adapter cable to the connector of the receiver.
- 2) **Push the button (2)** and connect the connecting cable to the adapter cable.

In this way, the operating voltage for the SLC/SLG440AS is switched on and the receiver switches to **Parameter setting mode**.

**The operating status is signalled in the following way:**

	7- segment display
	LED OSSD ON (red) active
	LED OSSD OFF (green) active

**Parameter setting:**

- 1) When the button (2) is briefly pressed, the display shows repeatedly

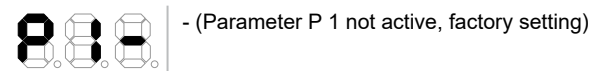

- 2) Select the desired parameter by means of the button (2) (briefly press the button)
- 3) Change the selected parameter by means of the button (2) (press the button for a long time)
  - 1. Press button (approx. 2.5 seconds) → - flashes (parameter not active)
  - 2. Enable button when → A static (parameter active)
- 4) Save the new configuration with the parameter Save **S.** (push the button for a long )
  - 1. Actuate button (approx. 2.5 seconds) → **S.** flashes
  - 2. Enable button when → **S.** static
  - 3. Automatic restart → "segment circulation" then P is displayed (saving operation successful)

If no restart takes place (**S.**), the saving operation has not been successful (i.e. the parameter changes have not been saved). Disconnect/reconnect the connecting cable and repeat the steps 1 to 3.

All parameters can be reset to the factory setting using parameter **C**. (clear/delete).

- 1) Press the button (approx. 2.5 seconds) → **C**. flashes
- 2) Enable the button when → **C**. static
- 3) Automatic restart → "Segment circulation", then **P** is displayed (all parameters have been deleted)

After the parameters have been set, the KA-0975 is removed and the connecting cable is connected to the receiver.

**Table Parameter setting SLC440AS**

No.	Parameter	Status	Note
<b>P 1</b>	Fixed blanking	- = not active A = Active	Position active saves all interrupted beam through Teach-in mode
<b>P 2</b>	Fixed blanking with movable edge region	- = not active A = Active	Tolerance in edge region +/- 1 beam - adjust safety distance!
<b>P 3</b>	Floating blanking 1 beam or 2 beams	- = not active 1 = 1 beam 2 = 2 beams	Blanking of max. 2 beams - adjust safety distance!
<b>S.</b>	Save	S.	Press button S1 to save changes (2.5...6.0 sec.)
<b>C.</b>	Clear/delete	C.	Press button S1 to save factory setting (2.5...6.0 sec.)
<b>d.</b>	Diagnostic/setting mode	d.	Switch to setting mode



**P 1 or P 2** - - When blanking is activated, all beams that are interrupted in the protection field at the time the button (2) is pressed (> 2.5 sec. with trailing edge) are blanked.  
**P 2** - Parameter combination P 1 and P 2 or P 2 and P 3 is not authorised. Status indication n = not available

**Table Parameter setting SLG440AS**

No.	Parameter	Status	Note
<b>P 1</b>	not available	n.	not available
<b>P 2</b>	not available	n.	not available
<b>P 3</b>	Floating blanking 1 light beam	- = not active 1 = 1 beam	Blanking of <b>one</b> beam, only for resolution 300 mm and 400 mm
<b>S.</b>	Save	S.	Press button S1 to save changes (2.5 ...6.0 sec.)
<b>C.</b>	Clear/delete	C.	Press button S1 to save factory setting (2.5 ...6.0 sec.)
<b>d.</b>	Diagnostic/setting mode	d.	Switch to setting mode



**P 1 and P 2** - not available!  
**P 6** - Beam coding A must also be set at the emitter, refer to chapter Beam coding A

### 3. Mounting

#### 3.1 General conditions

The following guidelines are provided as preventive warning notices to ensure a safe and appropriate handling. These guidelines are an essential part of the safety instructions and must therefore always be observed and respected.



- The AOPD must not be used on machines, which can not be stopped electrically in case of emergency.
- The safety distance between the AOPD and a hazardous machine movement must always be observed and respected.
- Additional mechanical safety guards must be installed so that the operator has to pass through the protection field to reach the hazardous machine parts.
- The AOPD must be installed so that the personnel always must be within the detection zone when operating the machine. An incorrect installation can lead to serious injuries.
- The safety inspections must be conducted regularly.
- The AOPD must not be exposed to inflammable or explosive gasses.
- Round M12 connecting cables with a minimum length of 0.2 m must be used.
- The SLC/SLG must be mounted by means of the mounting angles included in delivery.
- Device housing installed with at least 7.7 mm distance to metal surfaces.
- The fixing screws of the end caps and the mounting angle must be firmly tightened.

#### 3.2 Protection field and approach

The protection field of the AOPD consists of the entire range located between the protection field markings of emitter and receiver. Additional protective devices must ensure that the operator has to pass through the protection field to reach the hazardous machine parts.

The AOPD must be installed so that the personnel is always located within the detection zone of the safety device when operating the hazardous machine parts to be secured.

##### Correct installation

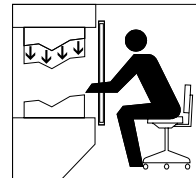

Hazardous machine parts can only be reached after passing through the protection field.

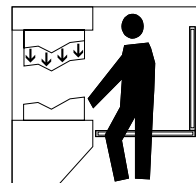

The presence of staff members between the protection field and hazardous machine parts must be prevented/avoided (protection against stepping over).

##### Unauthorised installation

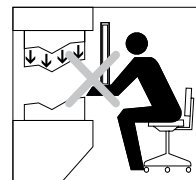

Hazardous machine parts can be reached without passing through the protection field.

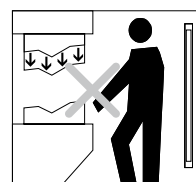

The presence of staff members between the protection field and hazardous machine parts is possible.

### 3.3 Alignment of the sensors

#### Procedure:

1. The emitter and the receiver must be fitted parallel to each other and at the same height.
2. Switch on the power supply for the SLC/SLG.
3. The 7-segment display in the receiver shows the current signal quality/fine setting (signalling, see chapter "setting mode") permanently in protective mode. First turn the emitter, then the receiver towards each other until the best possible signal quality of 3 crossbars is obtained (7-segment display) (note: 2 crossbars = sufficient). Fix the position with the two screws for each mounting bracket. If the set-up is not possible with fine setting, switch to set-up mode (see chapter "set-up mode"). The set-up mode leads to the best possible positioning of the sensors through the basic setting (position of the second and last beam) and the optimisation of the fine setting (total signal).

#### Status indication of the LED's:

OSSD ON (green) is active (ON), signal quality (orange) not active.

4. After positioning, the SLC/SLG is ready for operation.

### 3.4 Set-up tool and set-up mode



#### Set-up tool with 7-segment display

The function supports the best possible alignment between emitter and receiver.

In normal operation, the signal strength is permanently displayed on the receiver, when the safety enabling is switched on.

For the optical representation of the signal quality, two ranges, the signal strength at the 2nd and the last beam in the protection field (basic setting) and the optimal alignment quality of all beams (fine adjustment) are available.

#### Activating setting mode:

The set-up mode can be activated through the parameter setting menu by means of the parameter adapter KA-0975 (also refer to "Parameter setting").

If set-up mode is activated, you can switch between rough and fine setting by briefly pressing the button (2).

If the button is pressed for a longer period of time, the set-up tool is closed and the receiver switches to protective mode

#### Alignment:

##### Receiver not parallel

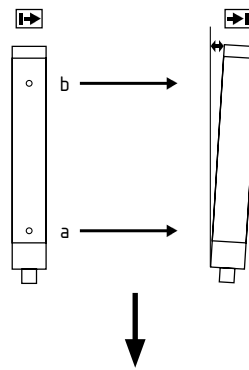

##### Both sensors parallel

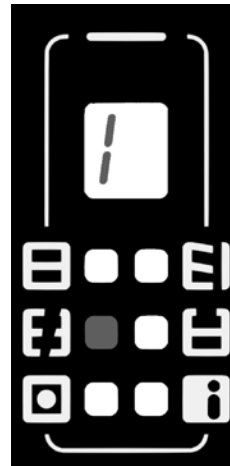
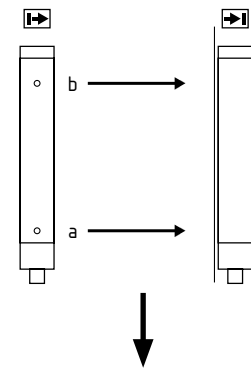

Beam (a) = receive signal OK  
Beam (b) = no receive signal

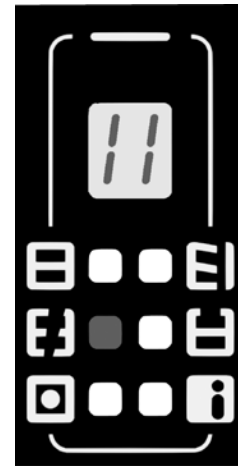

Beam (a) and beam (b) = receive signals OK

#### Basic setting indication:

The signal strength is displayed per beam with two segments for the 2nd (a) and the last (b) beam.

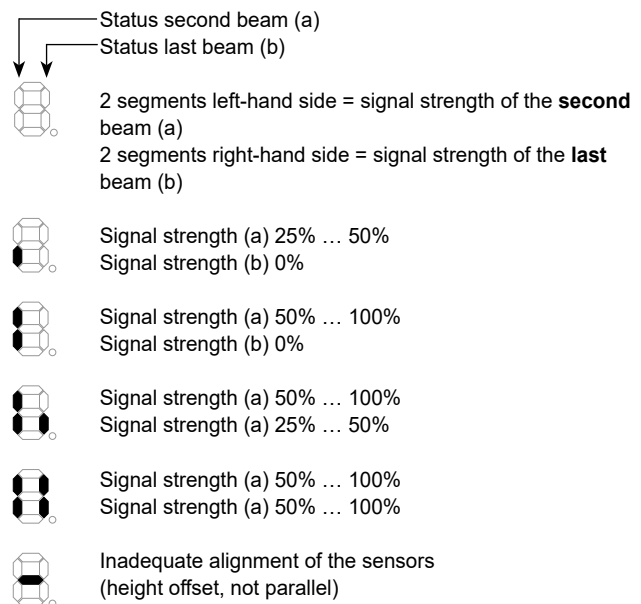

**CAUTION!** The signal strength of the SLG440AS is shown for the first (a) and the last (b) beam.



### Indication fine adjustment:

The fine adjustment is displayed by means of up to 3 segments (crossbars) for the best possible signal strength of all beams.



Best possible signal strength



Signal strength for normal operation OK



- Signal strength OK, if one or more beams in the protection field are covered (beam blanking)
- Signal strength insufficient, when no beams are covered



The safe operating status (high availability) is also ensured, when the best possible signal strength (3 crossbars) is not obtained due to soiling of the profiles or installation at nominal range.

### 3.5 Safety distance

The safety distance is the minimum distance between the protection field of the safety light curtain and the hazardous area. The safety distance must be observed to ensure that the hazardous area cannot be reached before the hazardous movement has come to standstill.

#### Calculation of the safety distance according to ISO 13855 and ISO 13857

The safety distance depends on the following elements:

- Stopping time of the machine (calculation by run-on time measurement)
- Response time of the machine and the safety light curtain and the downstream safety-monitoring module (entire safety system)
- Approach speed
- Resolution of the safety light curtain

#### Calculation of the safety distance for the safety light curtain SLC 440AS

The safety distance for resolutions 14 mm up to 40 mm is calculated by means of the following formula:

$$(1) S = 2000 \text{ mm/s} * T + 8 (d - 14) \text{ [mm]}$$

S = Safety distance [mm]

T = Total reaction time (machine run-on time, reaction time of the safety guard, relays, etc.)

d = Resolution of the safety light curtain

The approach speed is covered with a value of 2000 mm/s

If value  $S \leq 500$  mm after the calculation of the safety distance, then use this value.

If value  $S \geq 500$  mm, recalculate the distance:

$$(2) S = 1600 \text{ mm/s} * T + 8 (d - 14) \text{ [mm]}$$

If the new value  $S \geq 500$  mm, use this value as safety distance.

If the new value  $S < 500$  mm, use a minimum distance of 500 mm.

#### Example:

- Reaction time of the safety light curtain = 13 ms
- Resolution of the safety light curtain = 14 mm
- Stopping time of the machine = 330 ms

$$S = 2000 \text{ mm/s} * (330 \text{ ms} + 13 \text{ ms}) + 8(14 \text{ mm} - 14 \text{ mm})$$

$$S = 686 \text{ mm}$$

$S \geq 500$  mm, therefore new calculation with  $V = 1600$  mm/s

$$S = 549 \text{ mm}$$

### Safety distance to the hazardous area

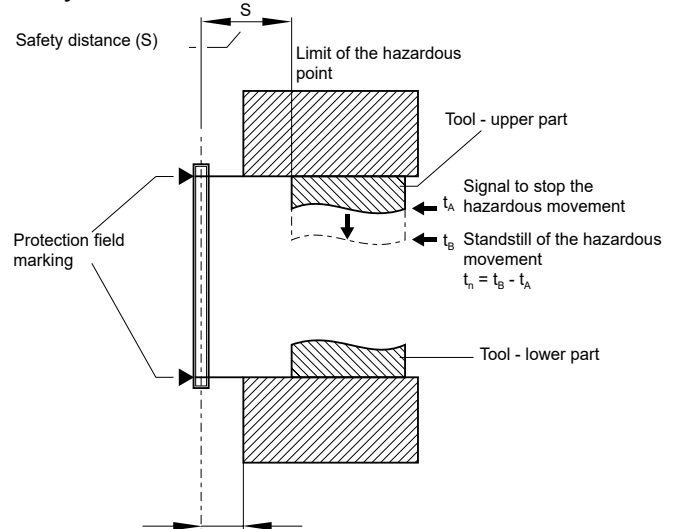

$\leq 75$  mm = max. distance for protection against stepping over  
To prevent persons from stepping over the protection field this dimension must be imperatively respected and observed.

#### Calculation of the safety distance for the multi-beam light grid SLG440AS

$$S = (1600 \text{ mm/s} * T) + 850 \text{ mm}$$

S = Safety distance [mm]

T = Total reaction time (machine stopping time, reaction time of the safety guard, relays, etc.)

K = Approach speed 1600 mm/s

C = Safety supplement 850 mm

#### Example

- Reaction time of the safety light grid = 13 ms
- Stopping time of the machine T = 170 ms

$$S = 1600 \text{ mm/s} * (170 \text{ ms} + 13 \text{ ms}) + 850 \text{ mm}$$

$$S = 1143 \text{ mm}$$

The following mounting heights must be observed:

Number of beams	Mounting height above reference floor in mm
2	400, 900
3	300, 700, 1100
4	300, 600, 900, 1200

### Safety distance to the hazardous area

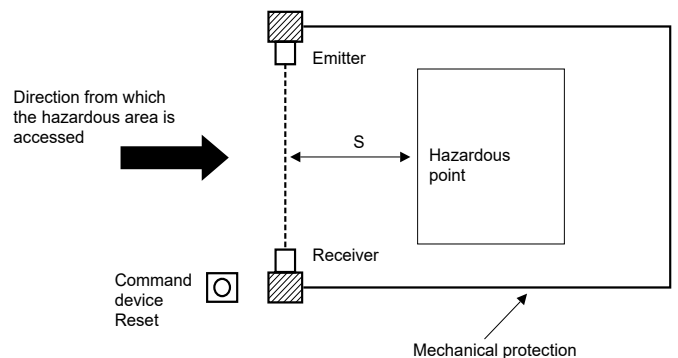

The formulae and calculation examples are related to the vertical set-up (refer to drawing) of the light curtain or light grid with regard to the hazardous point. Please observe the applicable harmonised EN standards and possible applicable national regulations.



The safety distance between the safety light grid and the hazardous point must always be respected and observed. If a person reaches the hazardous point before the hazardous movement has come to a standstill, he/she is exposed to serious injuries.



To calculate the minimum distances of the safety guards with regards to the hazardous point, the ISO 13855 and ISO 13857 must be observed. If an overlap of the protection field is possible, take care with the calculation of the safety distance referring to additional CRO according to the table A1 as per norm ISO 13855.

### 3.5.1 Minimum distance to reflecting surfaces

During the installation, the effects of reflecting surfaces must be taken into account. In case of an incorrect installation, interruptions of the protection field could possibly not be detected, which could lead to serious injuries. The hereafter-specified minimum distances with regard to reflecting surfaces (metal walls, floors, ceilings or parts) must be imperatively observed.

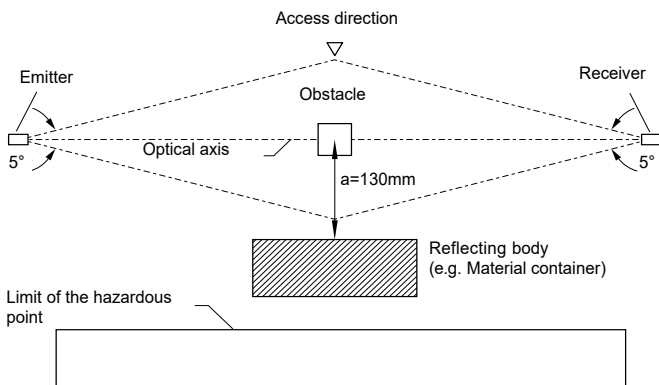

**Safety distance a**  
a [mm]

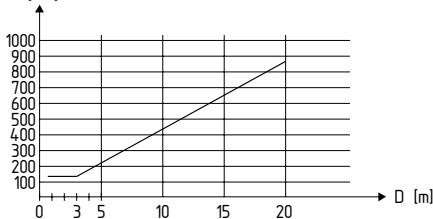

Calculate the minimum distance to reflecting surfaces as a function of the distance with an aperture angle of  $\pm 2.5^\circ$  degrees or use the value from the table below:

Distance between emitter and receiver [m]	Minimum distance a [mm]
0.2 ... 3.0	130
4	175
5	220
7	310
10	440

**Formula:**  $a = \tan 2.5^\circ \times L$  [mm]

a = Minimum distance to reflecting surfaces  
L = Distance between emitter and receiver

### 3.6 Dimensions emitter and receiver

SLC440AS, All measurements in mm.

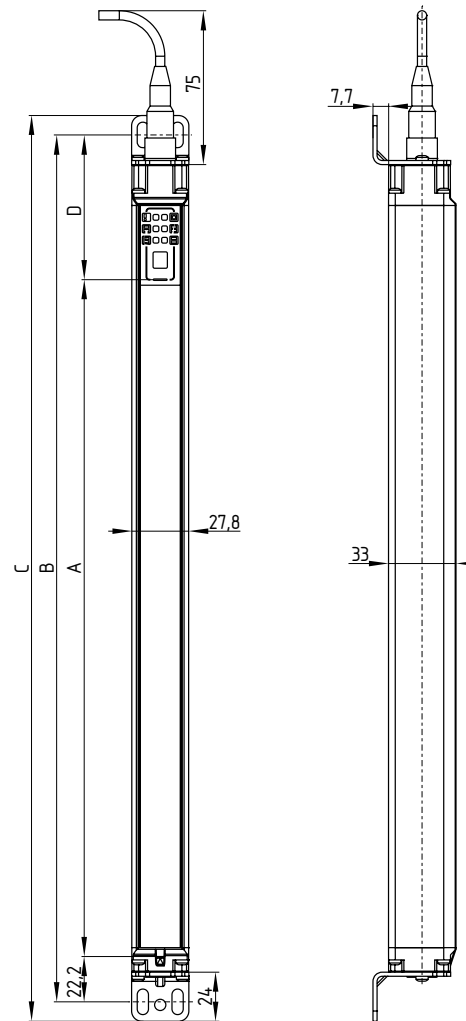

The receiver of the SLC440AS is in the area below the display 20 mm longer than the corresponding emitter.

#### Set-up tool:

Dimension D receiver = 90.8 mm  
Dimension D emitter = 70.8 mm

**Dimensions emitter SLC440AS**

Type	A Protected height ± 1	B Mounting dimension ± 1	C Total length ± 1
SLC440AS-ER-0170-XX	170	264	283
SLC440AS-ER-0250-XX	250	344	363
SLC440AS-ER-0330-XX	330	424	443
SLC440AS-ER-0410-XX	410	504	523
SLC440AS-ER-0490-XX	490	584	603
SLC440AS-ER-0570-XX	570	664	683
SLC440AS-ER-0650-XX	650	744	763
SLC440AS-ER-0730-XX	730	824	843
SLC440AS-ER-0810-XX	810	904	923
SLC440AS-ER-0890-XX	890	984	1003
SLC440AS-ER-0970-XX	970	1064	1083
SLC440AS-ER-1050-XX	1050	1144	1163
SLC440AS-ER-1130-XX	1130	1224	1243
SLC440AS-ER-1210-XX	1210	1304	1323
SLC440AS-ER-1290-XX	1290	1384	1403
SLC440AS-ER-1370-XX	1370	1464	1483
SLC440AS-ER-1450-XX	1450	1544	1563
SLC440AS-ER-1530-XX	1530	1624	1643
SLC440AS-ER-1610-XX	1610	1704	1723
SLC440AS-ER-1690-XX	1690	1784	1803
SLC440AS-ER-1770-XX	1770	1864	1883

**Dimensions receiver SLC440AS**

Type	A Protected height ± 0.1	B Mounting dimension ± 1	C Total length ± 1
SLC440AS-ER-0170-XX	170	284	303
SLC440AS-ER-0250-XX	250	364	383
SLC440AS-ER-0330-XX	330	444	463
SLC440AS-ER-0410-XX	410	524	543
SLC440AS-ER-0490-XX	490	604	623
SLC440AS-ER-0570-XX	570	684	703
SLC440AS-ER-0650-XX	650	764	783
SLC440AS-ER-0730-XX	730	844	863
SLC440AS-ER-0810-XX	810	924	943
SLC440AS-ER-0890-XX	890	1004	1023
SLC440AS-ER-0970-XX	970	1084	1103
SLC440AS-ER-1050-XX	1050	1164	1183
SLC440AS-ER-1130-XX	1130	1244	1263
SLC440AS-ER-1210-XX	1210	1324	1343
SLC440AS-ER-1290-XX	1290	1404	1423
SLC440AS-ER-1370-XX	1370	1484	1503
SLC440AS-ER-1450-XX	1450	1564	1583
SLC440AS-ER-1530-XX	1530	1644	1663
SLC440AS-ER-1610-XX	1610	1724	1743
SLC440AS-ER-1690-XX	1690	1804	1823
SLC440AS-ER-1770-XX	1770	1884	1903

**SLG440AS, All measurements in mm.**

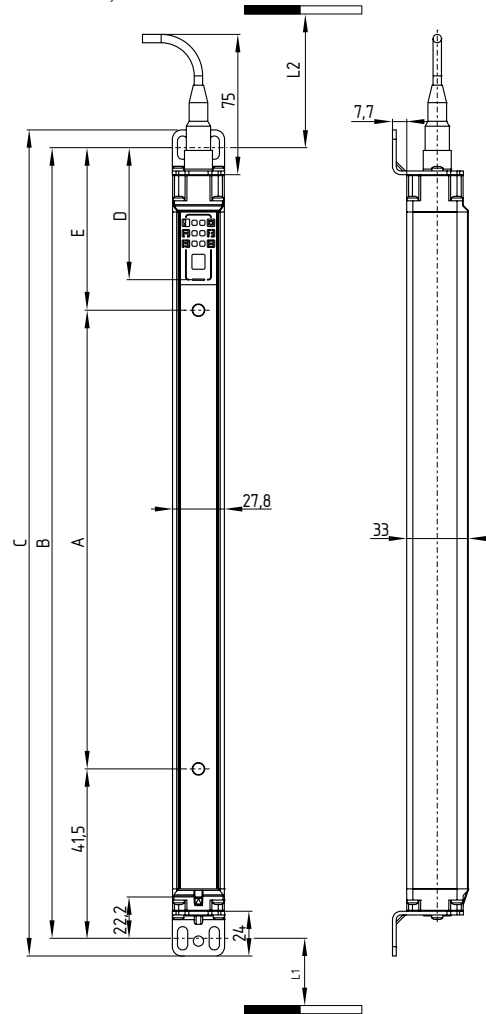

The receiver of the SLG440AS is in the area below the display 20 mm longer than the corresponding emitter.

**Set-up tool:**

Dimension D receiver = 90.8 mm

Dimension D emitter = 70.8 mm

**First beam:**

Dimension E receiver = 102.5 mm

Dimension E emitter = 82.5 mm

**Dimensions emitter SLG440AS**

Type	A Beam distance ± 1	B Mounting dimension ± 1	C Total length ± 1	L1	L2
SLG440AS-ER-0500-02	500	624	643	358.5	317.5
SLG440AS-ER-0800-03	400	924	943	258.5	217.5
SLG440AS-ER-0900-04	300	1024	1043	258.5	217.5

**Dimensions receiver SLG440AS**

Type	A Beam distance ± 1	B Mounting dimension ± 1	C Total length ± 1	L1	L2
SLG440AS-ER-0500-02	500	644	663	358.5	297.5
SLG440AS-ER-0800-03	400	944	963	258.5	197.5
SLG440AS-ER-0900-04	300	1044	1063	258.5	197.5

L1 = Mounting distance (mm) between floor and slotted hole centre (short end cap)

L2 = Mounting distance (mm) between floor and slotted hole centre (diagnostic window)

### 3.7 Fixing

#### Included in delivery:

#### Mounting kit MS-1100

The mounting kit consists of 4 pcs. steel angles and 8 pcs. fixing screws.

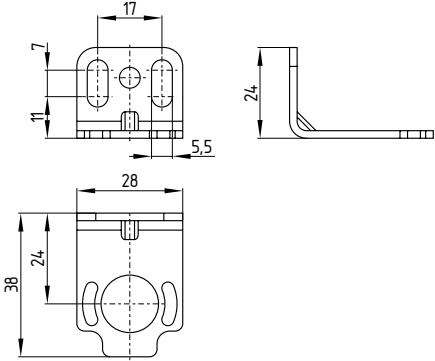

#### MSD5 spacer

The kit consists of 2 pcs. spacers. Available as of a protection zone height of 1050 mm. Mounting recommended in case of vibrations.

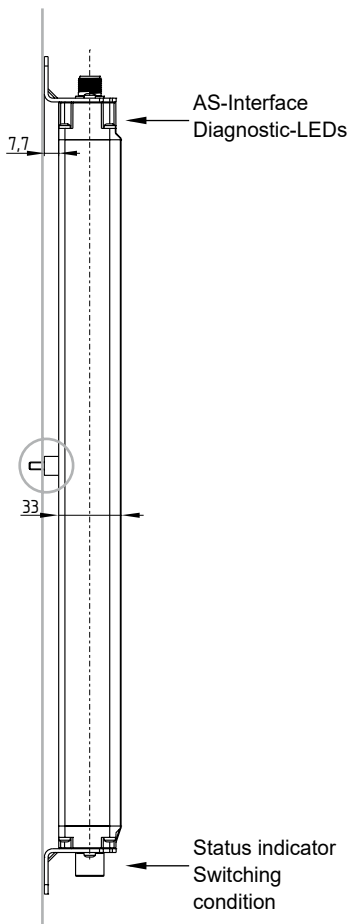
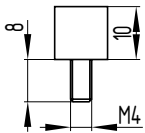

### Optional accessories

#### Centre support MS-1110

Mounting kit consists of 2 steel angles and 4 spacers for central fixing

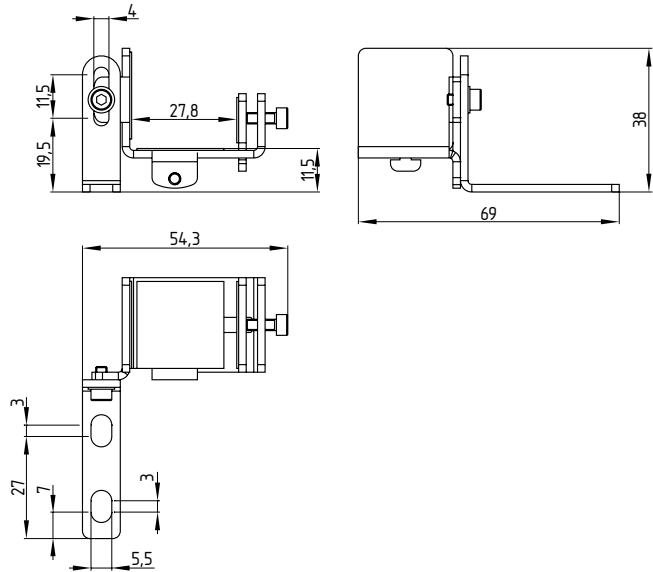

#### Integrated status indication

A status indication is integrated in the receiver of the SLC/SLG opposite the connecting side.

This status indication shows the switching condition of the safety light guard.

Green = outputs enabled

Red = outputs disabled

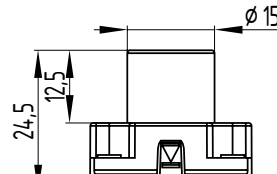

The integrated status indication **does not** change the mounting dimension B or the overall length C. The overall length of the Ls receiver changes by 10 mm.

#### 4. Electrical connection

##### 4.1 General information for electrical connection



The electrical connection may only be carried out by authorised personnel in a de-energised condition.

The connection to the AS-Interface system is realised through an M12 connector. The M12 connector is A-coded. The wiring configuration of the M12 connector is determined as follows (to EN 62026-2):

##### Pin assignment RECEIVER, 5-pole M12 connector

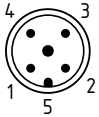

- PIN 1: AS-i +
- PIN 2: Aux –
- PIN 3: AS-i –
- PIN 4: Aux +
- PIN 5: parameter input

##### Pin assignment EMITTER, 4-pole M12 connector

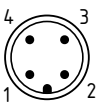

- PIN 1: spare
- PIN 2: Aux –
- PIN 3: spare
- PIN 4: Aux +

#### 5. Functions and configuration

##### 5.1 Programming the slave address

The slave address is programmed through the M12 connector. Any address from 1 to 31 can be set by means of the AS-i bus master or a hand-held programming device.

##### 5.2 Configuration of the safety monitor

The SLC/SLG440AS can be configured in the ASIMON configuration software with the following monitoring devices. (also refer to the ASIMON manual)

##### Double channel dependent

- Synchronisation time: 0.1 s
- Optionally with startup test
- Optional with local acknowledge



The configuration of the safety monitor must be tested and confirmed by a qualified and authorised safety expert/safety engineer.

##### 5.3 Status signal "safety release"

The "safety release" status signal from a Safety at Work slave can be cyclically queried by the control system through the AS-i master. To this effect, the 4 input bits with the varying SaW code of a Safety at Work slave are evaluated through an OR operation with 4 inputs in the control system.

#### 6. Diagnostic

##### 6.1 Status information LED

Receiver	Function	LED colour	Description
<p>OSSD ON OSSD OFF Restart</p>	OSSD ON	green	Safety outputs Signal condition ON
	OSSD OFF	red	Safety outputs Signal condition OFF
	Restart	yellow	Beam coding A is active
	Signal reception	orange	Safety-monitoring module of Signal reception
	Blanking	blue	Protection field(s) inactive (blanking)
	Information	yellow-green	Beam coding A is active
Emitter	Function	LED colour	Description
<p>Information</p>	Information	green	Function indication beam coding A
	Emitting	orange	Emitter active

RECEIVER LED	Status LED	Description
OSSD ON	ON	Protection field clear
OSSD OFF	ON	Protection field interrupted, system or configuration error
	ON	Error output refer to Fault diagnostic table
Restart	ON	Beam coding A is active
Signal reception	ON/flashing	Signal reception too low, check alignment and installation height between emitter and receiver cleaning the black profile cover
	AUS	Alignment between emitter and receiver OK, when the OSSD are enabled
Blanking	1 x flashing	Fixed blanking of the protection field(s)
	2 x flashing	Floating blanking, max. 1 beam
	3 x flashing	Floating blanking, 2 beams
	4 x flashing	Floating (max. 1 beam) and fixed blanking of protection field(s)
	5 x flashing	Floating (2 beams) and fixed blanking of protection field(s)
Information	6 x flashing	Fixed blanking with movable edge region
	flashing	Beam coding A is active

Emitter LED	Status LED	Description
Emitting	ON	Standard operation, emitter active
	flashing	Configuration error
Information	flashing	Beam coding A is active

## 6.2 Fault diagnostic

The light grid performs an internal self-test after the operating voltage is switched on and the protection field is enabled. When a fault is detected, an error number e.g. E2 is displayed at the receiver. Each fault display is followed by a one-second delay.

Status display	Fault feature	Action
	Supply voltage U-Aux	U-Aux = 24 VDC +/- 10%, check voltage source and primary voltage, note: after the fault message E2 has been displayed three times, a reset is executed.
	Errors at the internal OSSD outputs	Internal error: Short-circuit or cross-wire short at internal OSSD
	Beam blanking	Check the blanking area(s) of fixed or floating objects with the selected parameter setting, fault elimination - repeat configuration in the parameter setting, possibly adjust P 1, P 2, P 3
	Configuration error in parameter setting	Check parameter setting and save/accept with "S." or delete/clear with "C." delete/clear
	System error	Restart the system, if E 7 display persists, exchange components

The error display is reset after elimination of the error cause and after the receiver has been switched back on. The error indication displays a 3-digit system error code for every 10th display.

## 6.3 AS-i diagnostics indication

The AS-i LED indications in the end cap on the connecting side have the following meaning (to EN 62026-2):

AS-i LED (Duo-LED)	Meaning
Green	AS-i data transmission
Red	No data transmission or slave address = 0
Alternate flashing green / red	Internal device error / periphery error (FID) detected

## 6.4 Read-out of the parameter ports

The parameter port P0 to P3 of an AS-i slave can be read out through the control interface of the AS-i master (see component description) by using the "Write parameter" instruction (with hexadecimal value F). This (non-safe) diagnostic information from the reflected parameters or the answer to a "Write parameter instruction" can be used by the user for diagnostic purposes or for the control programme.

### Diagnostic information P0 ... P3

Parameter bit	Condition = 1
P0	-
P1	Poor beam quality
P2	-
P3	Internal device error detected (FID)

The warning message indicates a soiled or incorrectly adjusted BWS. The warning message indicates a soiled or incorrectly adjusted AOPD.

## 6.5 Diagnostic signal periphery error (FID)

An internal device error is transmitted as "periphery error" to the control system through the AS-i Master.

A "periphery error" (FID input of the AS-i chip) is signaled by the alternating red and green flashing of the AS-i duo LED on the AS-i device.

## 7. Set-up and maintenance

### 7.1 Check before start-up

Prior to start-up, the following items must be checked by the responsible person.

#### Wiring check prior to start-up:

- For the auxiliary voltage supply, a 24 VDC PELV unit must be used (refer to technical data).  
A power downtime of 20 ms must be bridged.
- Presence of a voltage supply with correct polarity at the SLC/SLG.
- The connecting cable of the emitter is correctly connected to the emitter and the connecting cable of the receiver is correctly connected to the receiver.
- If two or more SLC/SLG units are used within close range to each other, an alternating arrangement must be observed. Any mutual interference of the systems must be prevented.

#### Switch on the AOPD and check the operation in the following way:

The component performs a system test during approx. 2 seconds after the operating voltage has been switched on (indication through 7-segment display). After that, the outputs are enabled, if the protection field is not interrupted. The LED "OSSD ON" at the receiver is on.



In case of incorrect functionality, please follow the instructions listed in the chapter Fault diagnostic.

## 7.2 Maintenance



Do not use the SLG before the next inspection is terminated. An incorrect inspection can lead to serious and mortal injuries.

### Conditions

For safety reasons, all inspection results must be archived. The operating principle of the AOPD and the machine must be known in order to be able conducting an inspection. If the fitter, the planning technician and the operator are different persons, please make sure that the user has the necessary information at his disposal to be able conducting the maintenance.

### 7.3 Regular check

A regular visual inspection and functional test, including the following steps, is to be performed:

1. The component does not have any visible damages.
2. The optics cover is not scratched or soiled.
3. Hazardous machinery parts can only be accessed by passing through the protection field of the AOPD.
4. The staff remains within the detection area, when works are conducted on hazardous machinery parts.
5. The safety distance of the application exceeds the mathematically calculated one.

### Operate the machine and check whether the hazardous movement stops under the hereafter mentioned circumstances.

1. Hazardous machine parts do not move when the protection field is interrupted.
2. The hazardous machine movement is immediately stopped, when the protection field is interrupted with the test rod directly at the emitter, directly at the receiver and in the middle between the emitter and the receiver.
3. There is no hazardous machine movement when the test rod is within the protection field.
4. The hazardous machine movement comes to standstill, when the voltage supply of the AOPD is switched off.

### 7.4 Half-yearly inspection

The following items must be checked every six months or if a machine setting is changed.

1. Machine stops or does not inhibit any safety function.
2. No machine modification or connection change, which affects the safety system, has taken place.
3. The outputs of the AOPD are correctly connected to the machine.
4. The total response time of the machine does not exceed the response time calculated during the first commissioning.
5. The cables, the connectors, the caps and the mounting angles are in perfect condition.

### 7.5 Cleaning

If the optics cover of the sensors is extremely soiled, the OSSD outputs may be disabled. Clean with a clean, soft cloth with low pressure. The use of aggressive, abrasive or scratching cleaning agents, which could attack the surface, is prohibited.

## 8. Disassembly and disposal

### 8.1 Disassembly

The safety switchgear must be disassembled in a de-energised condition only.

### 8.2 Disposal

The safety switchgear must be disposed of in an appropriate manner in accordance with the national prescriptions and legislations.

## 9. Appendix

### 9.1 Contact

#### Consultancy / Sales



K.A. Schmersal GmbH & Co. KG  
Möddinghofe 30  
D-42279 Wuppertal  
Tel +49 (0) 202 64 74 -0  
Fax +49 (0) 202 64 74- 100

You will also find detailed information regarding our product variety on our website: [products.schmersal.com](http://products.schmersal.com)

#### Repair handling / shipping

Safety Control GmbH  
Am Industriepark 2a  
D-84453 Mühldorf/ Inn  
Tel +49 (0) 8631-18796-0  
Fax +49 (0) 8631-18796-1

10. EU Declaration of conformity

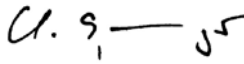
EU Declaration of conformity		
Original	Safety Control GmbH Am Industriepark 2a 84453 Mühldorf / Inn Germany	
We hereby certify that the hereafter described components both in their basic design and construction conform to the applicable European Directives.		
<b>Name of the component:</b>	SLC440AS SLG440AS	
<b>Type:</b>	See ordering code	
<b>Description of the component:</b>	Safety light curtain and safety light grid with integrated AS-i Safety at Work	
<b>Relevant Directives:</b>	Machinery Directive	2006/42/EG
	EMC-Directive	2014/30/EU
	RoHS-Directive	2011/65/EU
<b>Applied standards:</b>	EN 61496-1:2013 EN 61496-2:2013 EN ISO 13849-1:2015 EN 62061:2005 + Cor.:2010 + A1:2013 + A2:2015	
<b>Notified body for the prototype test:</b>	TÜV NORD CERT GmbH Langemarckstr. 20, 45141 Essen ID n°: 0044	
<b>EC-prototype test certificate:</b>	44 205 13166201	
<b>Person authorised for the compilation of the technical documentation:</b>	Oliver Wacker Möddinghofe 30 42279 Wuppertal	
<b>Place and date of issue:</b>	Mühldorf, 31. March, 2020	
SLC_SLG440AS-C-DE		
	Authorised signature <b>Klaus Schuster</b> Managing Director	Authorised signature <b>Christian Spranger</b> Managing Director



The currently valid declaration of conformity can be downloaded from the internet at [products.schmersal.com](http://products.schmersal.com).

