



EN Operating instructions.pages 1 to 6
Original

Content

1 About this document

1.1 Function 1

1.2 Target group: authorised qualified personnel. 1

1.3 Explanation of the symbols used 1

1.4 Appropriate use 1

1.5 General safety instructions 1

1.6 Warning about misuse 2

1.7 Exclusion of liability 2

2 Product description

2.1 Ordering code 2

2.2 Special versions. 2

2.3 Purpose 2

2.4 Technical data 2

2.5 Safety classification 2

3 Mounting

3.1 General mounting instructions 2

3.2 Dimensions 2

4 Electrical connection

4.1 General information for electrical connection. 3

4.2 Connection. 3

4.3 Pin configuration 3

4.4 Wiring examples 3

4.5 Commissioning 4

4.6 Operating principle. 4

4.7 Reset wiring configuration 4

4.8 Diagnostic / error messages 4

5 Maintenance

5.1 Maintenance of the safety-monitoring module. 4

5.2 Wear test at the rubber profile 4

6 Disassembly and disposal

6.1 Disassembly. 4

6.2 Disposal 4

7 Appendix

7.1 EU Declaration of conformity 5

7.2 Mounting and inspection protocol 6

1. About this document

1.1 Function

This operating instructions manual provides all the information you need for the mounting, set-up and commissioning for the safe operation and disassembly of the safety-monitoring module. The operating instructions must be available in a legible condition and a complete version in the vicinity of the device.

1.2 Target group: authorised qualified personnel

All operations described in this operating instructions manual must be carried out by trained specialist personnel, authorised by the plant operator only.

Please make sure that you have read and understood these operating instructions and that you know all applicable legislations regarding occupational safety and accident prevention prior to installation and putting the component into operation.

The machine builder must carefully select the harmonised standards to be complied with as well as other technical specifications for the selection, mounting and integration of the components.

1.3 Explanation of the symbols used



Information, hint, note:

This symbol is used for identifying useful additional information.



Caution: Failure to comply with this warning notice could lead to failures or malfunctions.

Warning: Failure to comply with this warning notice could lead to physical injury and/or damage to the machine.

1.4 Appropriate use

The products described in these operating instructions are developed to execute safety-related functions as part of an entire plant or machine. It is the responsibility of the manufacturer of a machine or plant to ensure the correct functionality of the entire machine or plant.

The safety-monitoring module must be exclusively used in accordance with the versions listed below or for the applications authorised by the manufacturer. Detailed information regarding the range of applications can be found in the chapter "Product description".

1.5 General safety instructions

The user must observe the safety instructions in this operating instructions manual, the country specific installation standards as well as all prevailing safety regulations and accident prevention rules.



Further technical information can be found in the Schmersal catalogues or in the online catalogue on the Internet: www.schmersal.net.

The information contained in this operating instructions manual is provided without liability and is subject to technical modifications.

There are no residual risks, provided that the safety instructions as well as the instructions regarding mounting, commissioning, operation and maintenance are observed.

1.6 Warning about misuse



In case of inadequate or improper use or manipulations of the safety-monitoring module, personal hazards or damages to machinery or plant components cannot be excluded.

1.7 Exclusion of liability

We shall accept no liability for damages and malfunctions resulting from defective mounting or failure to comply with this operating instructions manual. The manufacturer shall accept no liability for damages resulting from the use of unauthorised spare parts or accessories.

For safety reasons, invasive work on the device as well as arbitrary repairs, conversions and modifications to the device are strictly forbidden; the manufacturer shall accept no liability for damages resulting from such invasive work, arbitrary repairs, conversions and/or modifications to the device.

2. Product description

2.1 Ordering code

This operating instructions manual applies to the following types:

SE-304 C

2.2 Special versions

For special versions, which are not listed in the order code below 2.1, these specifications apply accordingly, provided that they correspond to the standard version.

2.3 Purpose

The safety-monitoring module evaluates the signals of 1 to 4 SE safety edges (signal generators). The safety-monitoring module is designed for fitting into control cabinets (IP54).

The safety-monitoring module only must be used in combination with the SE-R/SE-T transmitter/receiver unit (SE-SET sensor kit) of the signal generator.



The signal generator and the corresponding safety-monitoring module together build the safety edge system to EN ISO 13856-2.

If one of the connected safety edges is actuated, the safety contacts of the safety-monitoring module are opened.



The entire concept of the control system, in which the safety component is integrated, must be validated to the relevant standards.

2.4 Technical data

Standards:	EN ISO 13856-2
Start conditions:	Automatic or start button
Feedback circuit (Y/N):	yes
Response time:	< 17 ms
Pull-in delay with reset button:	100 ms up to 2 s
Rated operating voltage U_b :	24 VDC (+20 % / -10%) 24 VAC (+10 % / -10%)
Power consumption:	< 4 W
Frequency range:	50 Hz
Fuse rating supply voltage:	1 A slow blow

Monitored inputs:

Cross-wire detection:	yes
Wire breakage detection:	yes
Earth connection detection:	yes

Outputs:

Stop category 0:	1
Stop category 1:	0
Number of safety contacts:	1
Number of auxiliary contacts:	0
Number of signalling outputs:	1
Max. switching capacity of the safety contacts:	2 A / 230 VAC 2 A / 24 VDC

Signalling output:	PNP-open-Collector; $U_{x1} = U_b - 1 V$; $I_{max} = 50 mA$
--------------------	--

Utilisation category to EN 60947-5-1:	AC-15: 230 V / 2 A DC-13: 24 V / 2 A
---------------------------------------	---

Recommended fuse for the contacts:	2 A slow blow
------------------------------------	---------------

Switching capacity:	max. 1500 VA
---------------------	--------------

Mechanical life:	> 10 million operations
------------------	-------------------------

LED:	Supply voltage, Safety edge functions
------	--

Ambient conditions:

Environmental temperature:	+5 °C ... +55 °C
----------------------------	------------------

Protection class:	Enclosure: IP40, Terminals: IP20, Clearance: IP54
-------------------	---

Degree of pollution:	2
----------------------	---

Overvoltage category:	III
-----------------------	-----

Resistance to vibration:	10 ... 55 Hz, amplitude 0.15 mm
--------------------------	---------------------------------

Mounting:	Snaps onto standard DIN rail to EN 60715
-----------	--

Connection type:	Screw connection
------------------	------------------

Pre-wired cable:

Capacity:	150 nF/km
-----------	-----------

Resistance:	28 Ohm/km
-------------	-----------

Cable section:	2.5 mm ² wire or 1.5 mm ² strand with conductor ferrules
----------------	---

Weight:	175 g
---------	-------

Dimensions (H x W x D):	100 x 22.5 x 121 mm
-------------------------	---------------------

2.5 Safety classification

Standards:	EN ISO 13849-1
------------	----------------

PL:	d
-----	---

Control Category:	3
-------------------	---

PFH-value:	1.01 x 10 ⁻⁷ /h up to max. 5,000 switching cycles/year
------------	---

Service life:	20 years
---------------	----------

The aforementioned safety values are applicable to the combination consisting of the SE-SET sensor kit (SE-T transmitter, SE-R receiver) and the safety-monitoring module. The hollow rubber profile must not be taken into consideration for the safety classification.

3. Mounting

3.1 General mounting instructions

Mounting of the safety switching device in a control cabinet (IP54).

Mounting: snaps onto standard DIN rails to EN 60715.

The device is equipped with a latching element at the rear for fixing onto a standard DIN rail.

3.2 Dimensions

Device dimensions (H/W/D): 100 x 22.5 x 121 mm

4. Electrical connection

4.1 General information for electrical connection



The electrical connection may only be carried out by authorised personnel in a de-energised condition.

4.2 Connection

Only the output contact 13/14 is a safety contact. The output contact X1 is a signalling contact. The output contacts must be preceded by a fuse (2 A slow blow).

4.3 Pin configuration

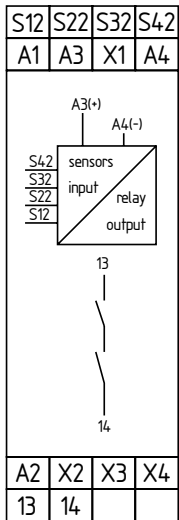

A1 / A2: 24 VAC/DC

The supply voltage is on = LED "power" is on

Terminal connections:

- Switch operating voltage on at terminals A1(+) and A2(-).
- Closing the feedback circuit: connect the start/reset button between X2 and X3 or force an automatic release through the establishment of a bridge between X2 and A3 (refer to reset wiring configuration).
- Integrate the safety outputs in the machine circuit: terminal 13/14
- Signalling output X1 is no safety output and must only be used as signalling contact (relay output).
- Connect transmitter/receiver: wire the terminals brown, white, green from the transmitter and the receiver according to the wiring example.
- Provide adequate protective wiring of the output contacts in case of capacitive and inductive loads.
- Enabling paths safely separated up to 300 V to DIN EN 60664-1.

4.4 Wiring examples

Input

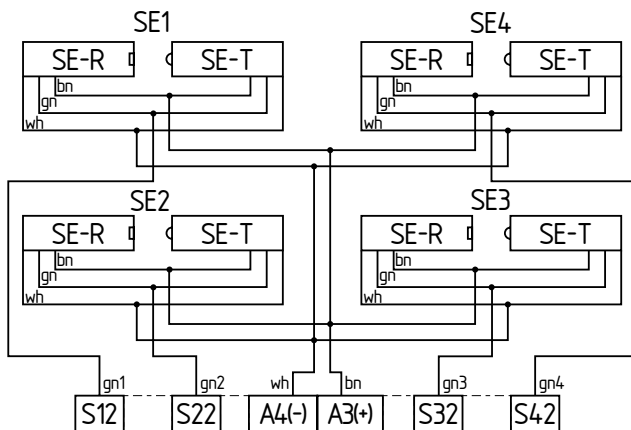

If less than 4 safety edges are connected, the following diagram must be observed. Unused inputs must be connected as shown.

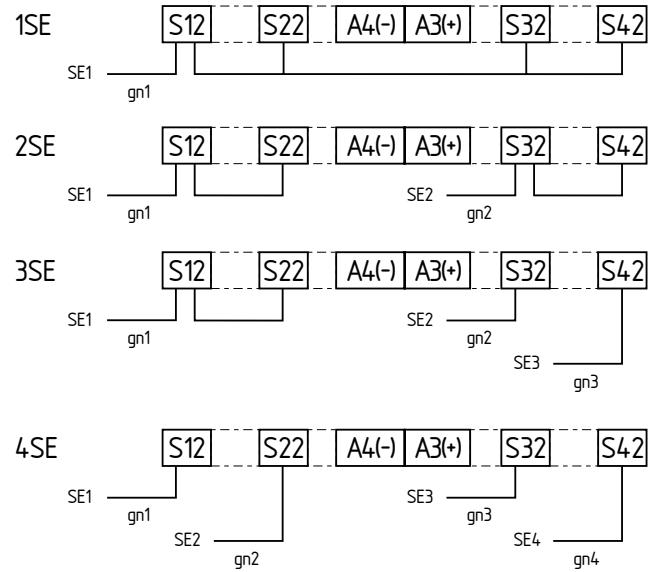

Output level

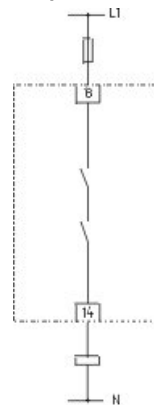

Safety output:

Safety edges not actuated = safety output enabled
= 13/14 closed
= LED SE1 – SE 4 on

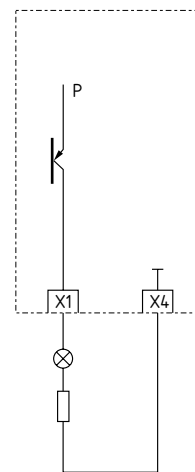

max. 50 mA

Signalling output:

Signalling output without contact
Safety edges actuated = signalling output 24 VDC
Mass potential: terminal X4
e.g. 24 VAC supply voltage, X4 furnishes the mass for the DC signalling output.

4.5 Commissioning

The safety function of the safety-monitoring module must be tested. The following conditions must be previously checked and met:

1. Correct fitting of the safety-monitoring module
2. Fitting and integrity of the power cable

4.6 Operating principle

Manual reset (X2 - X3)

When the operating voltage is switched on, the safety contact 13/14 is open; signalling contact X1 is connected to 24 VDC. To start the component, the reset button (X2/X3) must be actuated (0-1-0 edge, refer to reset wiring configuration). The relays K1, K2 are energised, when the light path in the profile is clear. The machine enabling circuit 13/14 is closed and X1 goes to a high-impedance state. If the light path in the profile is interrupted, the machine enabling circuit 13/14 is interrupted. If the light path is cleared again, the reset button must be actuated to trigger a new start.

Automatic reset

In case of a bridge between the terminal X2 and A3.

4.7 Reset wiring configuration

Manual reset

A reset button can be connected between the terminals X2 and X3. In this operating mode, the component behaves in accordance with the requirements to EN ISO 13856-2 (state diagram A2) and par. 5.2.2 of EN ISO 13849-1 (a "0-1-0" edge transition is expected within 100 ms up to 2 s).

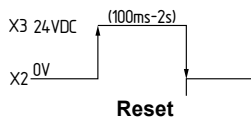

Automatic reset

Switching behaviour to EN ISO 13856-2 (state diagram A3) is generated through the establishment of a bridge from X2 to A3. The safety contacts are closed immediately after the release of all safety edges.

4.8 Diagnostic / error messages

- The safety-monitoring module detects short-circuits and wire breakage of the connecting cables from the sensors.
- Malfunctions of the contacts: in case of contact welding, no reactivation is possible after actuation of the safety edge.
- LED "SEn" off: safety edge "n" actuated
- LED "ENABLE" off: at least one safety edge actuated or no (manual) reset yet
- LED "POWER" off: no supply voltage
- The LED SE 1...4 signal flashing light. Internal fault switch the supply voltage off and back on. If the fault is still signalled, the component needs to be exchanged.
- No reaction to manual reset (X2/X3): safety edge still actuated, safety edge or cable connection damaged, defective safety-monitoring module (refer to reset wiring configuration)

5. Maintenance

5.1 Maintenance of the safety-monitoring module

In the case of correct installation and adequate use, the safety-monitoring module features maintenance-free functionality. A regular visual inspection and functional test, including the following steps, is recommended:

- Check the correct fixing of the safety monitoring module
- Check the cable for damage.

Under rough operating conditions, we recommend a regular check of the function of the entire system.

(Also refer to the enclosed mounting and inspection protocol.)

Damaged or defective components must be replaced.

5.2 Wear test at the rubber profile

The safety edge must be checked once a year for damages by means of a visual check. In case of damages, the safety edge must be exchanged, as in this case, the safety function no longer is completely guaranteed. The following checks must be performed:

- Check the rubber profile for damages, e.g. cracks
- Check if the elasticity of the rubber profile is not affected, e.g. due to ageing
- Check for damages and correct fixing
- Trigger the safety edge by manually actuating the rubber profile

6. Disassembly and disposal

6.1 Disassembly

The safety monitoring module must be disassembled in the de-energised condition only.

6.2 Disposal

The safety monitoring module must be disposed of in an appropriate manner in accordance with the national prescriptions and legislations.

7. Appendix

7.1 EU Declaration of conformity

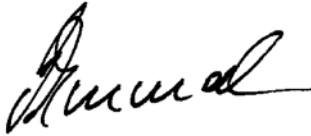
EU Declaration of conformity		
Original	K.A. Schmersal GmbH & Co. KG Möddinghofe 30 42279 Wuppertal Germany Internet: www.schmersal.com	
We hereby certify that the hereafter described components both in their basic design and construction conform to the applicable European Directives.		
Name of the component:	SE-304 C	
Type:	See ordering code	
Description of the component:	Safety-monitoring module for monitoring optoelectronic safety edges of the SE 40/70 series with SE-SET sensor kit	
Relevant Directives:	Machinery Directive	2006/42/EC
	EMC-Directive	2014/30/EU
	RoHS-Directive	2011/65/EU
Applied standards:	EN ISO 13856-2:2013 EN ISO 13849-1:2008 + AC:2009 EN 12978:2003 + A1:2009	
Notified body for the prototype test:	TÜV Rheinland Industrie Service GmbH Am Grauen Stein 51105 Köln ID n°: 0035	
EC-prototype test certificate:	01/205/5007.01/14	
Person authorised for the compilation of the technical documentation:	Oliver Wacker Möddinghofe 30 42279 Wuppertal	
Place and date of issue:	Wuppertal, February 3, 2017	
SE-304 C-F-EN		
	Authorised signature Philip Schmersal Managing Director	



The currently valid declaration of conformity can be downloaded from the internet at www.schmersal.net.



7.2 Mounting and inspection protocol



Mounting and inspection protocol

Check of the safety edge system

Under the scope of the commissioning and the regular maintenance of the machine, the following items of the safety edge system must be checked and inspected by a professional:

Machine/ Construction project _____	Signal evaluation _____
Date of first putting into operation _____	Profile signal generator _____
Name of the fitter _____	Emitter _____
	Receiver _____
	Aluminium profile _____

1. Visual check of the signal generator
Inspection of the signal generator's surface and the connections, to ensure the absence of damages preventing correct operation.

2. Visual check of the signal transmission
Check and inspection of the connections and the wiring for defects and changes.

3. Visual check of the signal evaluation
Check and inspection of the enclosure and its electrical connections for defects and changes.

4. Functional test of the safety edge
Actuation of the signal generator at multiple arbitrary positions. The sensitivity of the safety edge must be present throughout the entire active actuating surface. Check of the LED's in the evaluation. The machine must not be restarted if hazards are present.

Please enclose the protocol in the machine documentation.

Date / Signature:

K. A. Schmersal GmbH & Co. KG
Möddinghofe 30, D - 42279 Wuppertal
Postfach 24 02 63, D - 42232 Wuppertal

Phone: +49 - (0)2 02 - 64 74 - 0
Telefax: +49 - (0)2 02 - 64 74 - 1 00
E-Mail: info@schmersal.com
Internet: <http://www.schmersal.com>