



EN Operating instructions. page 1
Original

Purpose

The adapter is required for installation of the device heads of the N series in hole diameter 30.5 mm.

Mounting

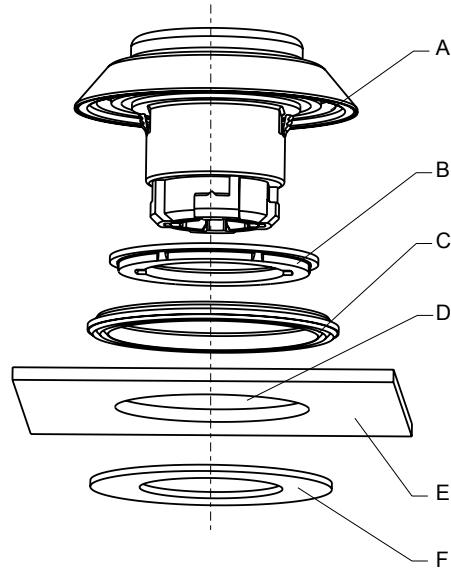

Key

- A: Remove possible iron chips
- B: Adapter ring EDT-28
- C: Seal EDT-27
- D: Mounting hole Ø 30.5 mm
- E: Front plate
- F: Washer MUE-2

Included in delivery: Adapter ring EDT-28, Seal EDT-27, Washer MUE-2

K. A. Schmersal GmbH & Co. KG
Mödinghofe 30, D - 42279 Wuppertal
Postfach 24 02 63, D - 42232 Wuppertal

Phone: +49 - (0)2 02 - 64 74 - 0
Telefax: +49 - (0)2 02 - 64 74 - 1 00
E-Mail: info@schmersal.com
Internet: <http://www.schmersal.com>

