

Datasheet - Mounting set MS AZ 15/16 P

Safety switch with separate actuator / AZ 16 / Accessories AZ 16

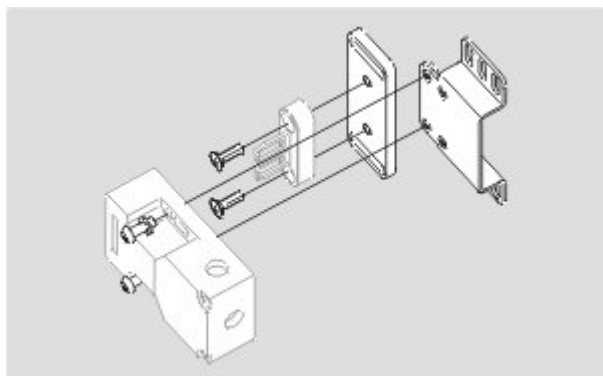

(Minor differences between the printed image and the original product may exist!)

Ordering details

Product type description	Montagebausatz MS AZ 15/16 P
Article number	101150373
EAN code	4030661287782
eCl@ss	27-27-92-91

Global Properties

Product name	Montagebausatz
Weight	240 g

Mechanical data

mounting	Mounting parallel to safety guard
----------	-----------------------------------

notice

The mounting sets can only be used in conjunction with actuator AZ 15/16-B6.

Included in delivery

Included in delivery

- Roundhead screw M5 x 16 per ISO 7380
- Roundhead screw M5 x 10 per ISO 7380
- Washer DIN 125-5,3
- U-profile AZ 16
- Mounting angle AZ 16
- Counter sunk screw M5 x 16 DIN 7991
- Mounting plate AZ 16/AZM 161

Documents

Images

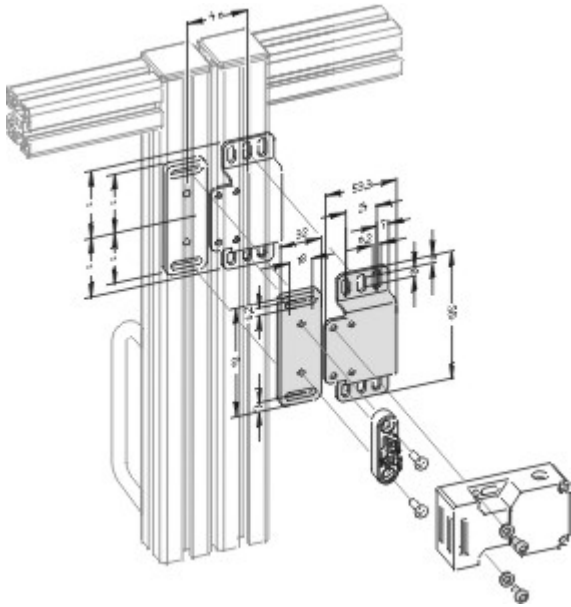

Product graph (exploded-view drawing)

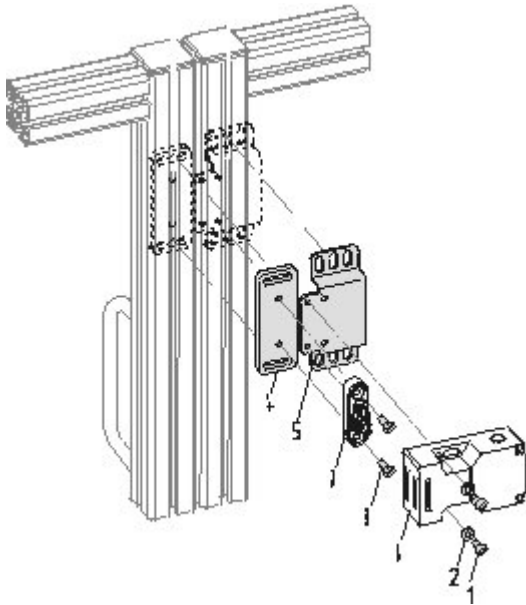

Product graph (exploded-view drawing)