



EN Operating instructions.pages 1 to 6
Original

Content

1 About this document

1.1 Function 1

1.2 Target group: authorised qualified personnel. 1

1.3 Explanation of the symbols used 1

1.4 Appropriate use 1

1.5 General safety instructions 1

1.6 Warning about misuse 2

1.7 Exclusion of liability 2

2 Product description

2.1 Ordering code 2

2.2 Actuator overview 2

2.3 Special versions. 2

2.4 Purpose 3

2.5 Technical data 3

2.6 Safety classification emergency stop. 3

3 Mounting

3.1 General mounting instructions. 3

3.2 Dimensions 3

3.3 Mounting of the pushbutton and illuminated pushbutton caps for option -2875. 3

3.4 Fixing 3

3.5 Inscription plates 4

4 Electrical connection

4.1 General information for electrical connection. 4

5 Set-up and maintenance

5.1 Functional testing. 4

5.2 Maintenance 4

6 Disassembly and disposal

6.1 Disassembly. 4

6.2 Disposal 4

7 Appendix

7.1 Pin configuration 5

8 EU Declaration of conformity

1. About this document

1.1 Function

This operating instructions manual provides all the information you need for the mounting, set-up and commissioning to ensure the safe operation and disassembly of the safety switchgear. The operating instructions must be available in a legible condition and a complete version in the vicinity of the device.

1.2 Target group: authorised qualified personnel

All operations described in this operating instructions manual must be carried out by trained specialist personnel, authorised by the plant operator only.

Please make sure that you have read and understood these operating instructions and that you know all applicable legislations regarding occupational safety and accident prevention prior to installation and putting the component into operation.

The machine builder must carefully select the harmonised standards to be complied with as well as other technical specifications for the selection, mounting and integration of the components.

1.3 Explanation of the symbols used

 Information, hint, note:
This symbol is used for identifying useful additional information.

 **Caution:** Failure to comply with this warning notice could lead to failures or malfunctions.
Warning: Failure to comply with this warning notice could lead to physical injury and/or damage to the machine.

1.4 Appropriate use

The products described in these operating instructions are developed to execute safety-related functions as part of an entire plant or machine. It is the responsibility of the manufacturer of a machine or plant to ensure the correct functionality of the entire machine or plant.

The safety switchgear must be exclusively used in accordance with the versions listed below or for the applications authorised by the manufacturer. Detailed information regarding the range of applications can be found in the chapter "Product description".

1.5 General safety instructions

The user must observe the safety instructions in this operating instructions manual, the country specific installation standards as well as all prevailing safety regulations and accident prevention rules.

 Further technical information can be found in the Schmersal catalogues or in the online catalogue on the Internet: www.schmersal.net.

The information contained in this operating instructions manual is provided without liability and is subject to technical modifications.

There are no residual risks, provided that the safety instructions as well as the instructions regarding mounting, commissioning, operation and maintenance are observed.

1.6 Warning about misuse



In case of improper use or manipulation of the safety switchgear, personal hazards or damages to machinery or plant components cannot be excluded. The relevant requirements of the standard ISO 13850 must be observed.

1.7 Exclusion of liability

We shall accept no liability for damages and malfunctions resulting from defective mounting or failure to comply with this operating instructions manual. The manufacturer shall accept no liability for damages resulting from the use of unauthorised spare parts or accessories.

For safety reasons, invasive work on the device as well as arbitrary repairs, conversions and modifications to the device are strictly forbidden; the manufacturer shall accept no liability for damages resulting from such invasive work, arbitrary repairs, conversions and/or modifications to the device.

2. Product description

2.1 Ordering code

This operating instructions manual applies to the following types:

BDF200-①-②-③-④-⑤-⑥-⑦

No.	Option	Description
①	NH NHK ...	Emergency stop without protective collar Emergency stop with protective collar Operating element at position 1
②	20 11 10	with emergency stop: 2 NO contact at position 2 - 4 without emergency stop: 2 NO contacts at position 1 - 4 with emergency stop: 1 NO / 1 NC contact at position 2 - 4 without emergency stop: 1 NO / 1 NC contact at position 1 - 4 with emergency stop: 1 NO contact at position 2 - 4 without emergency stop: 1 NO contact at position 1 - 4
③	...	Operating element at position 2
④	...	Operating element at position 3
⑤	...	Operating element at position 4
⑥	G24	without indicator lamp
⑦	2875	with indicator lamp, red (only for contact variant -10) Pushbutton caps for pushbuttons and illuminated pushbuttons included in the kit



Unused positions are labelled "B" and are sealed with a blanking plug in factory.
The operating elements can only be retrofitted at the factory.



In accordance with the Machinery Directive, the type plate of safety components is type plate labelled "Safety component".



Only if the information described in this operating instructions manual are realised correctly, the safety function and therefore the compliance with the Machinery Directive is maintained.

2.2 Actuator overview

Emergency stop pushbutton

- without protective collar: ordering suffix **NH**
- with protective collar: ordering suffix **NHK**
- Pull to reset
- 1 NO contact / 2 NC contacts or 2 NC contacts

Illuminated pushbutton LT

- with concave button or without fitted button cap when the type designation ends with -2875.
- 2 NO contacts, 1 NO contact / 1 NC contact or 1 NO contact

Pushbutton DT

- with concave button
- 2 NO contacts, 1 NO contact / 1 NC contact or 1 NO contact

Illuminated signal LM

Mushroom push button PT

- without latching
- 2 NO contacts, 1 NO contact / 1 NC contact or 1 NO contact

selector switches WS20, WS21, SWS20

- 1 latched position
- 2 NO contacts, 1 NO contact / 1 NC contact or 1 NO contact

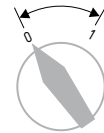

Selector switches WS30, WS31

- 2 latched positions to the left/right of the zero position
- 1 NO contact for each switching position for version -20 or 1 NC contact (position 1) and 1 NO contact (position 2) for version -11

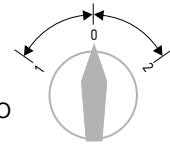

WT20, WT21, SWT20 (key-operated) selector switches

- 1 touch position and automatic return to the zero position
- 2 NO contacts, 1 NO contact / 1 NC contact or 1 NO contact



Selector switches WT30, WT31

- 2 touch positions to the left/right of the zero position and automatic return to the zero position
- 1 NO contact for each switching position for version -20 or 1 NC contact (position 1) and 1 NO contact (position 2) for version -11

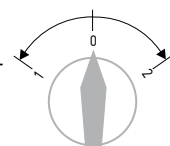

Selector switches WTS30, WTS31

- 1 touch position right and automatic return to the zero position and 1 latched position left of the zero position
- 1 NO contact for each switching position for version -20 or 1 NC contact (position 1) and 1 NO contact (position 2) for version -11

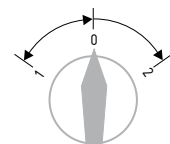

2.3 Special versions

For special versions, which are not listed in the order code below 2.1, these specifications apply accordingly, provided that they correspond to the standard version.

2.4 Purpose

The modular BDF200 control panel is installed on the safety guard of a machine or plant. It enables the operator to activate for instance the emergency stop, start/stop and reset functions.



The user must evaluate and design the safety chain in accordance with the relevant standards and the required safety level.



The entire concept of the control system, in which the safety component is integrated, must be validated to the relevant standards.

2.5 Technical data

Standards:	IEC 60947-5-1, IEC 60947-5-5
Material of the enclosure:	glass-fibre reinforced thermo-plastic, self-extinguishing
Protection class:	IP65
Cable entry:	1x M20
Cable cross-section of the cable glands:	Ø 6...13 mm
Ambient temperature:	-25 °C ... 65 °C
Climatic resistance:	to DIN EN 60068 Part 2 - 30
Overvoltage category:	III
Degree of pollution:	3
Material of the contacts:	AgNi 10, gold-plated
Rated operating current/voltage I _e /U _e :	AC-15: 2 A / 24 VAC DC-13: 1 A / 24 VDC
Thermal test current I _{the} :	2.5 A
Max. fuse rating:	2.5 A slow blow
Contact system:	Cross-Point system
Contact force:	0.5 N per contact point = 1 N per contact
Switching of low voltages:	min. 5 V / 1 mA
Switching frequency:	1,200 s/h
Rated insulation voltage U _i :	250 V
Rated impulse withstand voltage U _{imp} :	2.5 kV
Bounce duration:	< 2 ms at 100 mm/s actuating speed
Mechanical life:	1 million operations; emergency stop: 100,000 operations
Switch travel:	approx. 3 mm
Resistance to shock:	100 g / 6 ms
Resistance to vibration:	20 g, 10 ... 100 Hz
Wiring configuration:	to IEC 60947-1
Actuating force at stroke end (1 NC/1 NO):	8 N
Lamp socket:	BA5S, LED, max. length 17 mm
LED change:	from front
LED power consumption (operating elements):	16 mA
Power consumption indicator lamp, red:	20 mA



Input Terminal wire size AWG 14-22 TQ Lb In. 2-4
For use in NFPA79, Industrial Machinery, only.
The power-source has to be an isolated secondary source limited by a listed fuse rated 3 A min. 24 VAC/DC.

2.6 Safety classification emergency stop

Standards:	ISO 13849-1
B _{10D} :	100,000
Service life:	20 years

$$MTTF_D = \frac{B_{10D}}{0,1 \times n_{op}} \quad n_{op} = \frac{d_{op} \times h_{op} \times 3600 \text{ s/h}}{t_{cycle}}$$

(Specifications can vary depending on the application-specific parameters h_{op}, d_{op}, t_{cycle} as well as the load.)

3. Mounting

3.1 General mounting instructions

For the correct fixing of the BDF200 control panel, the device is provided with two mounting holes for M5 screws. Any mounting position.



Please observe the relevant requirements of the standards ISO 12100, ISO 14119 and ISO 14120.

3.2 Dimensions

All measurements in mm.

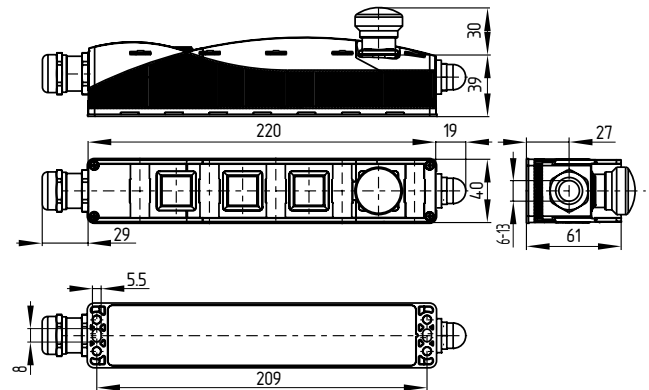

3.3 Mounting of the pushbutton and illuminated pushbutton caps for option -2875



The caps for the pushbuttons and illuminated pushbuttons are only suitable for a one-time mounting. Disassembly of the caps could cause damages to the component.
The caps must be mounted immediately after unpacking the control panel, in order to avoid soiling of the inner pushbutton compartment by gross dirt particles / dust.

The caps for the pushbuttons and illuminated pushbuttons are mounted in the following manner:

1. Take the pushbutton or illuminated pushbutton cap as well as the rubber disk out of the kit
2. Take the control panel out of the protective packaging
3. Place the rubber disk on the pushbutton surface
4. Install the pushbutton or illuminated pushbutton cap onto that
5. Fix the cap



The cap "clicks" when it is engaged

6. Check the smooth actuation of the pushbutton
7. Repeat this procedure for all other pushbuttons



After the pushbutton or illuminated pushbutton cap is mounted, the proper fitting and the smooth actuation of the pushbutton must be checked. The button must return autonomously from the actuated to the non-actuated state and the cap must be at the same height as the component edging.

3.4 Fixing

Remove the cover of the enclosure a and b (screws: Torx 10).



When opening the enclosure cover, please avoid damage to the connecting cables.



Caution!

Do not touch electrostatically loaded elements.
Do not touch the printed circuit board.

Use 2 x M5 cylindrical screws ISO 4762 (DIN 912) for the assembly.



When closing the enclosure cover, please observe that the individual cables are not caught between the actuator and the contact element.

After fitting, the cover screws must be tightened with a tightening torque of 0.7 ... 0.8 Nm.

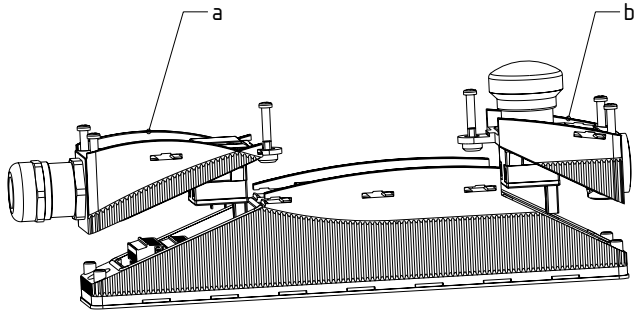

When closing the enclosure cover, ensure that the emergency stop module is flush with the bottom section and that the cover screws are screwed in as far as they will go. The emergency stop safety function must be checked by an appointed safety technician / safety representative once successfully installed.

3.5 Inscription plates

The marking on the inscription plates (included in delivery) is carried out by colour change by laser. The effects of heat may change the colour of the surface.

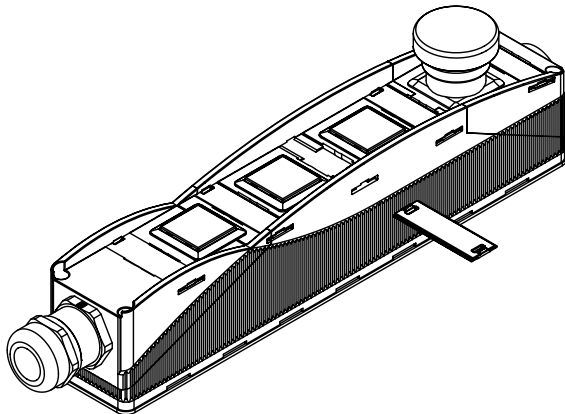

It must be ensured that the top is inscribed.

4. Electrical connection

4.1 General information for electrical connection



The electrical connection may only be carried out by authorised personnel in a de-energised condition.

The cable entry is realised by a metric M20 x 1.5 gland (included in delivery, tightening torque of connecting piece 4.0 Nm; tightening torque of cap nut 3.0 Nm). This gland must be dimensioned by the user so that it is suitable for the cable used.

The maximum cable section is 16 x 0.5 mm², incl. conductor ferrules.

Wiring examples: see appendix

5. Set-up and maintenance

5.1 Functional testing

The function of the component must be tested. The following conditions must be previously checked and met:

1. The installation is executed according to the instructions
2. The connection is executed correctly
3. The cable is correctly executed and connected.
4. For the types with extension ...-2875, the proper fitting and the smooth operation of the pushbuttons must be checked after the installation of the pushbutton and illuminated pushbutton caps

5.2 Maintenance

In case of correct installation in accordance with the instructions described above, the component requires little maintenance. For use in extreme conditions, we recommend routine maintenance including the following steps:

1. Check the correct fixing of the control panel
2. Remove particles of dust and soiling
3. Check cable entry and connections
4. For the types with extension ...-2875, the smooth operation of the pushbuttons and the illuminated pushbuttons must be checked.

Damaged or defective components must be replaced.

6. Disassembly and disposal

6.1 Disassembly

The product must be disassembled in a de-energised condition only.

6.2 Disposal

The product must be disposed of in an appropriate manner in accordance with the national prescriptions and legislations.

7. Appendix

7.1 Pin configuration

BDF200-NH-11-...

1 NO contact / 2 NC contacts for emergency stop at position 1
 1 NO contact / 1 NC contact for operating elements at position 2 - 4

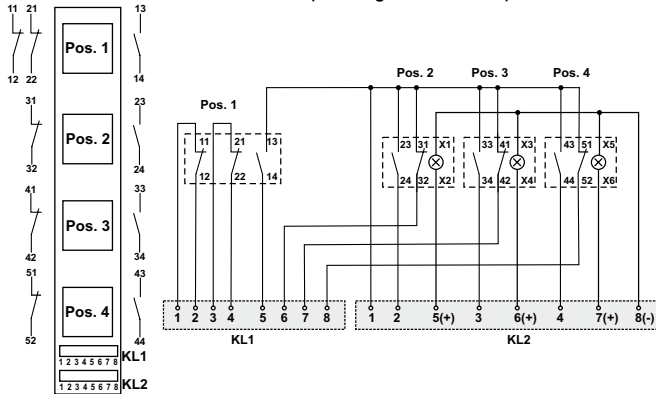

BDF200-NH-20-...

1 NO contact / 2 NC contacts for emergency stop at position 1
 2 NO contacts for operating elements at position 2 - 4

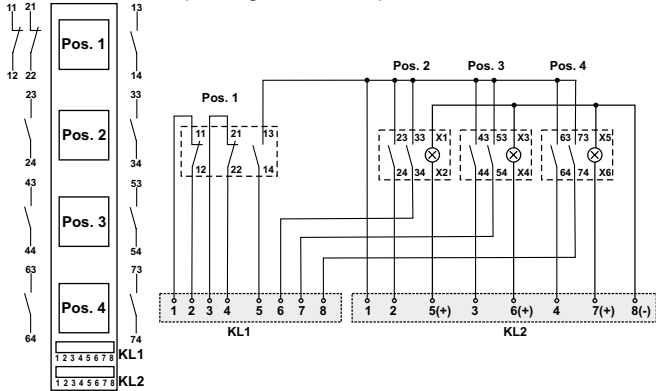

BDF200-NH-10-...

2 NC contacts for emergency stop at position 1 and indicator lamp (red)
 1 NO contact for operating elements at position 2 - 4 and indicator lamp (red)

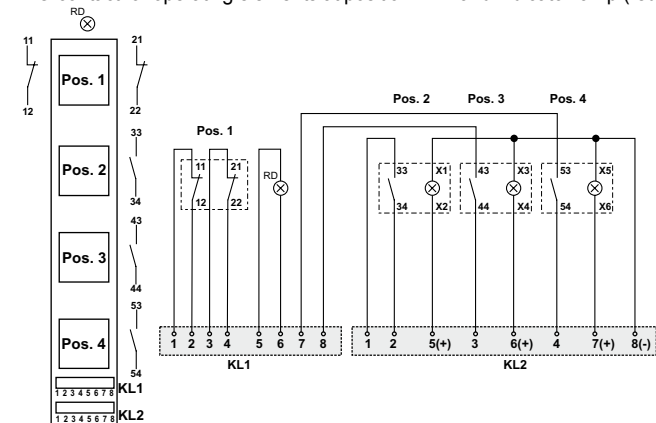

BDF200-...-11-...

1 NO contact / 1 NC contact for operating elements at position 1 - 4

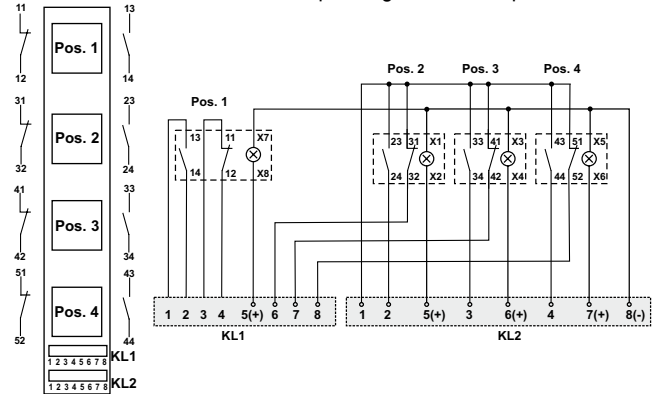

BDF200-...-20-...

2 NO contacts for operating elements at position 1 - 4

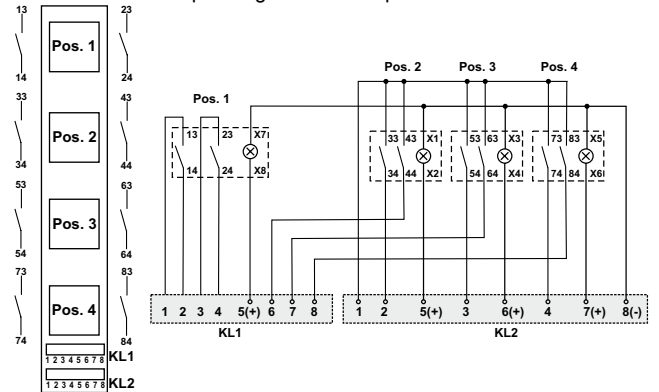

BDF200-...-10-...

1 NO contact for operating elements at position 1 - 4 and indicator lamp (red)

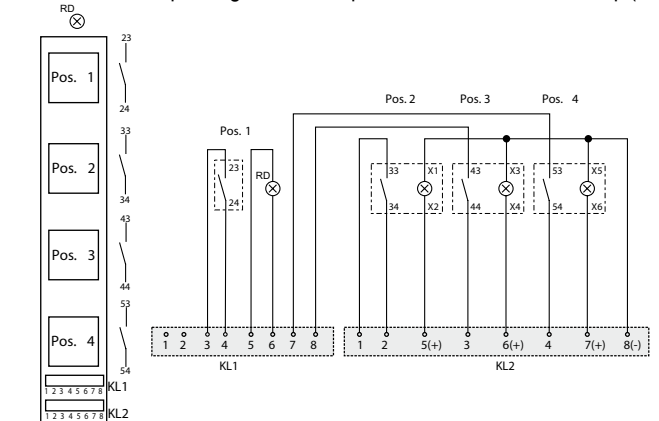

8. EU Declaration of conformity

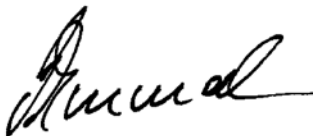
EU Declaration of conformity		
Original	K.A. Schmersal GmbH & Co. KG Möddinghofe 30 42279 Wuppertal Germany Internet: www.schmersal.com	
We hereby certify that the hereafter described components both in their basic design and construction conform to the applicable European Directives.		
Name of the component:	BDF200	
Type:	See ordering code	
Description of the component:	Control panel	
Relevant Directives:	Machinery Directive ¹⁾ RoHS-Directive	2006/42/EG 2011/65/EU
Affixing of the CE conformity mark:	¹⁾ for safety components, whose type plate is labelled "Safety component"	
Applied standards:	DIN EN 60947-5-1:2010, DIN EN 60947-5-5:2015, DIN EN ISO 13850:2008	
Person authorised for the compilation of the technical documentation:	Oliver Wacker Möddinghofe 30 42279 Wuppertal	
Place and date of issue:	Wuppertal, 12. March xx, 2018	
		
	Authorised signature Philip Schmersal Managing Director	

BDF200-E-EN



The currently valid declaration of conformity can be downloaded from the internet at www.schmersal.net.



K. A. Schmersal GmbH & Co. KG
Möddinghofe 30, D - 42279 Wuppertal
Postfach 24 02 63, D - 42232 Wuppertal

Phone: +49 - (0)2 02 - 64 74 - 0
Telefax: +49 - (0)2 02 - 64 74 - 1 00
E-Mail: info@schmersal.com
Internet: <http://www.schmersal.com>