

Ex Protection – ATEX

Explosion Protection Catalogue | Version 05

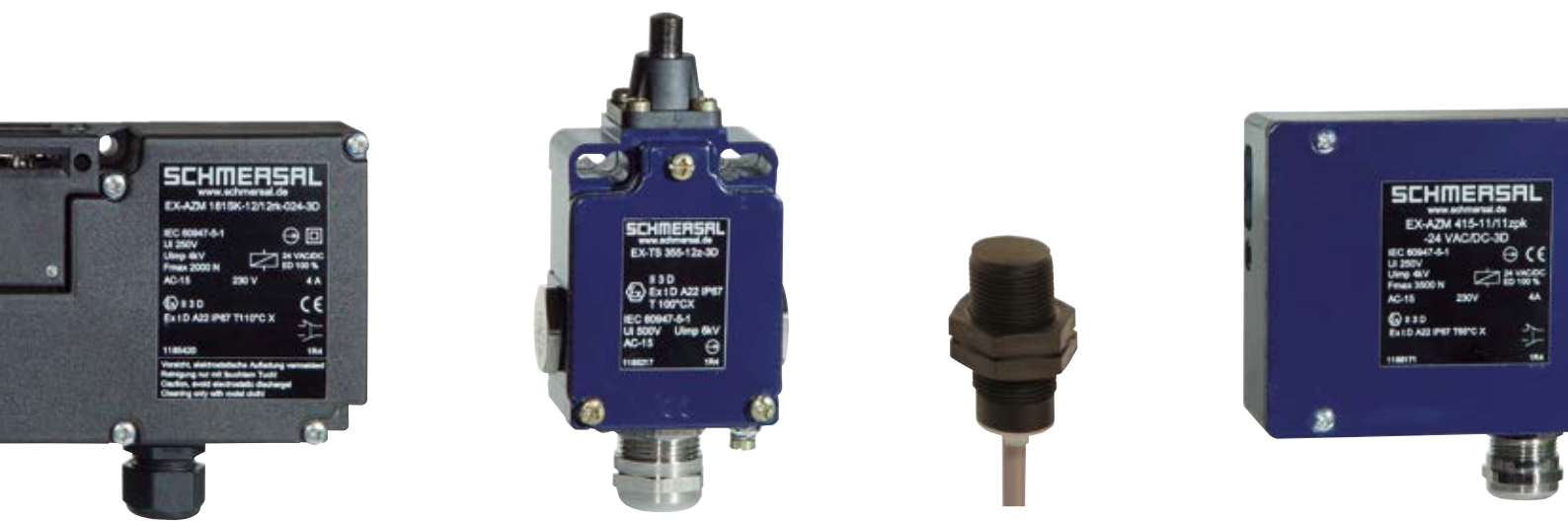

www.schmersal.net

You will also find detailed information regarding our product variety on our website: www.schmersal.net.



Online documentation in 13 languages

The online catalogue for our customers is permanently updated. The Main catalogue can be consulted on the Internet in as much as 13 languages.

The technical data of our entire product range are always up-to-date. The declarations of conformity, the test certificates and the mounting instructions can be consulted or even downloaded as well.

Service for designers

The online catalogue also includes the technical drawings of our products – a special service to designers. In this way, they can be downloaded and directly fed in CAD-systems.

The Schmersal homepage furthermore contains up-to-date information on general subjects, technical articles on machine safety as well as news regarding events and trainings. To be bookmarked!

The direct way

If you need further information or you want personal advice, you can call us as well: + 49-(0) 2 02-64 74-0.

The addresses of our representations in Germany and abroad can be found on the front pages of this catalogue.

**We are at your disposal –
anyplace, anywhere, anytime!**



Attention!

The data specified in this catalogue are carefully checked typical standard values. Subject to technical modifications and error.

Content

Introduction	The basics of explosion protection	4
Safety-monitoring modules	PROTECT SRB 101EXi.....	16
	PROTECT SRB 200EXi.....	18
Safety switch	EX-AZ 16-...-3D	22
	EX-AZ 335-...-3D	25
	EX-AZ 355-...-3D	26
	EX-AZ 415-...-3D	28
	EX-AZ 3350-...-3D	30
Solenoid interlocks	EX-AZM 170-...-3G/D	34
	EX-AZM 161-...-3D	36
	EX-AZM 415-...-3D	40
Position switches	EX-Z/T 235-...-3D	44
	EX-Z/T 335-...-3G/D	54
	EX-Z/T 355-...-3G/D	55
	EX-MAF 330-...-3D	60
	EX-T 335-.....	62
	EX-T/M 441-...	68
	EX-T/M 250-...	69
	EX-TS 064-...	70
	EX-MS 064-...	71
	EX-T. 064-...	73
	EX-M. 064 R	74
	EX-M. 064 L.....	75
Safety switch for hinged guards	EX-TV.S 335.....	78
Belt alignment switches / Slack-wire switch	EX-T/M 441-...	82
	EX-T/M 250-...	83
Pull-wire emergency-stop switches	EX-ZQ 900-3D.....	86
	EX-T3Z 068-...	88
Safety sensors	EX-BNS 250-...-3G/D.....	92
	EX-BNS 33-...-3G/D.....	94
	EX-BNS 120-...-3G/D.....	96
	EX-BNS 180-...-3G/D.....	98
	EX-BNS 303-...-3G/D	100
	EX-CSS 180-...-3G/D	102
Magnetic reed switches	EX-BN 20-...-3G/D	106
Control devices and indicator lights	EX-RDT.....	114
	EX-RDM.....	114
	EX-RDL.....	115
	EX-RDLM.....	115
	EX-RMLH.....	116
	EX-RDP40	117
	EX-RDRZ45	118
	EX-RDRZ45rt.....	119
	EX-RW...21/32	120
	EX-RW...21.1/32.1	120
	EX-RS	122
	EX-RF10	124
	EX-RF03	124
	EX-RLDE ws 24	125
	EX-EBG 331.O.....	126
	EX-EBG 633.O.....	126
	EX-EBG 665.O.....	126
Trapped key system	EX-SHGV-...-3G/D (selector switch; key-operated selector switch)	134
	EX-SVM1-...-2G/D (interlocking device)	135
	EX-SHGV-...-2G/D (guard locking device)	136

The basics of explosion protection

The implementation of the ATEX Directives (ATEX: ATmosphères EXplosibles) in Europe has changed the way of thinking with regard to the explosion protection. The manufacturers must follow the directive 94/4/EC to fulfill the harmonised standards in Europe. The directive is obligatory in all Member States and transposed into national law. This was carried out until 2003. On the other side the users have to fulfill the directive 1999/92/EC regarding the basic safety and health requirements for operation. Both Directives are based upon the standards listed in the Official Journal (OJ) of the European Commission. Not only the gas explosive protection is now standardised, but also the protection for dust atmospheres. In a few countries, e.g. in Germany, explosion protection regulations existed already at national level, however not harmonised.

Due to the internationalisation and the standardisation on EN basis, the standards defining the requirements on equipment to be used in explosive atmospheres will gradually be re-

placed by the European Standards series EN 60079. Hybrid mixtures from gas and dust are included in the standardisation work as well.

The mechanical explosion protection required by the ATEX Directives however still is in its "infancy".

The comprehensive product portfolio from Schmersal and Elan Schaltelemente complies with the requirements of the standards and directives. Our existing products and our innovations are consistently developed and refined on the basis of the current standards as well as the amendments, which are in the transitional stage. In this way, both the standard requirements and safety technology are integrated in the potentially explosive areas.

Source of ignition	Examples of the cause
Sparks	Mechanically generated sparks (e.g. by friction, stroke or cutting removal operations), electric sparks
Electric arcs/flashovers	Short-circuit, switching operations
Hot surfaces	Current in electrical installations, heaters and radiators, machining, heating during operation
Flames and hot gases	By combustion reactions, spark projection during welding
Electrical installations	Even extra-low voltages ($U < 50$ V) still can generate sufficient energy to ignite an explosive atmosphere. Opening/closing of contacts, loose or defective contacts
Static electricity	Separately arranged conductive parts, many plastics
Equalizing currents	Reverse current from generators, earth connection in case of faults, induction
Electromagnetic waves in the $3 \times 10^{11} \dots 3 \times 10^{15}$ Hz range	Laser beam for range finding, especially in case of beam focusing
High frequency $10^4 \dots 3 \times 10^{12}$ Hz	Radio signals, industrial high-frequency generators for heating, drying, cutting, etc.
Lightning	Atmospheric disturbances
Ionizing radiation	X-ray device, radioactive substances, energy absorption leads to heating
Ultrasonic	Energy absorption in solid/liquid substances leads to heating
Adiabatic compression and shock waves	Strokewise opening of valves
Exothermal reactions	Chemical reaction



The basic physic and technical principles

Complete combustion

Combustion or burning is a complex sequence of exothermic chemical reactions. A fire starts when a flammable and/or combustible material with an adequate supply of oxygen is exothermically disintegrated. Depending on the speed of combustion, we speak of deflagration, explosion or detonation.

A complete combustion causes significant damages, which various with the combustion speed.

Order of magnitude of the speed of combustion

Deflagration	cm/s
Explosion	m/s
Detonation	km/s

Explosion

An explosion can only occur, when three factors come together: flammable material in ignitable quantities, oxygen and an ignition source. If one component is missing, no exothermic reaction will occur.

Oxygen

When a flammable substance is mixed with oxygen, a potentially explosive mixture is created. For gases, the concentration ratio determines whether an explosion is possible. The mixture can only be ignited if the concentration of the substance in air is within the lower and upper explosive limits. Mixtures with concentrations smaller or greater these limits will not explode. A few chemically unstable substances (e.g. acetylene, ethylene oxide) have self-decomposing properties and therefore can also produce exothermal reactions without oxygen.

In these cases, the upper explosion limit (UEL) is 100 vol. %. For pressurised gases, the explosion ranges change. Dusts are also classified by a lower explosion limit (approx. at 20...60 g/m³) and an upper explosion limit (approx. at 2...6 kg/m³).

Potentially explosive substance

Any flammable substance in the form of gas, mist, vapour or dust is considered as potentially explosive substance. For mists and dusts, a potentially explosive atmosphere occurs when the drop or the particle size is smaller than 1 mm. Frequently-used mists, aerosols and dusts have a particle size between 0.001 mm and 0.1 mm. Dusts with larger particle sizes are not combustible.

Deposits of dust can be compared to porous elements and have hollow portion of up to 90%. The increase of temperature of dust deposits can cause the spontaneous ignition of the dust-like flammable substance. If a deposit of dust with small particle size is swirled up, the dust, along with the oxygen in the air, forms a combustible dust/air mix. The bigger the size reduction, the higher the explosion danger, since the surface of the hollow space increases. Dust explosions are often the consequence of smouldering dust layers which become stirred up and already carry the ignition initiation.

The potential danger of explosive dust atmospheres and the selection of the appropriate safety measures are evaluated by means of the safety characteristics of the substances concerned. To this end, dusts are classified in accordance with two of their substance-specific properties:

- Conductivity

Dusts are considered to be conductive when they have a specific electric resistance of up to 10⁹ ohmmeters.

- Combustibility

Combustible dusts are characterised by the fact that they can burn or smoulder when mixed with air and that they form explosive mixtures along with oxygen under atmospheric pressure and at temperatures ranging from -20°C to +60°C.

The safety characteristics of swirled up dusts are for instance the minimum ignition energy and the ignition temperature, whereas for deposits of dust the smouldering temperature is a characteristic feature.

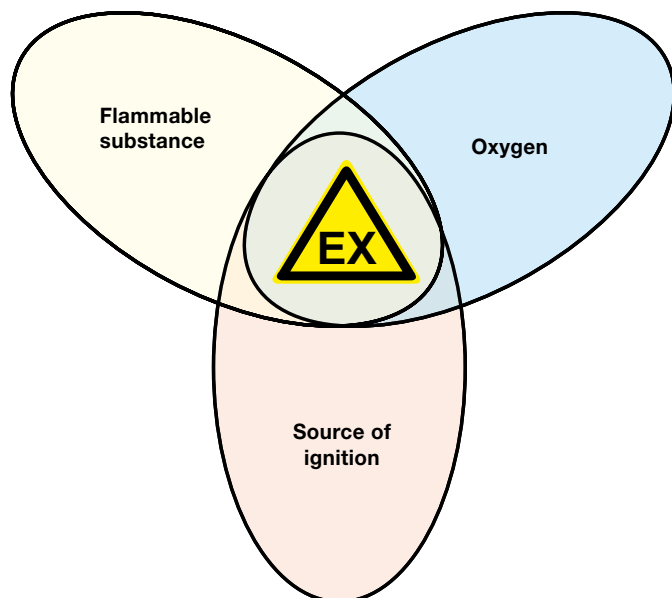

The basics of explosion protection

EN 60079-10/14

Classification of zones and selection of equipment

Setting-up installations in potentially explosive areas involves a great deal of precautions to be taken. For instance, the equipment, the resources, the cables and conductors as well as the construction have to meet special requirements. In case of doubt, the consultation of experts during the planning is recommended.

Risk assessment

It is the responsibility and duty of the user to perform a risk analysis prior to installing new facilities.

He must verify where there is a risk of explosion and then divide areas into zones accordingly. Every plant must be examined for its particularities.

If nonetheless an explosion would be caused, the possible hazard scenario must be taken into consideration in the forefront. Can chain reaction occur, are damages to the building to be expected and which are the impacts of the explosion of subsequent plant components and parts?

Potential interactions with adjacent plants can occur, which cannot be produced on the individual plant.

The risk analysis requires a great deal of experience as well as a correct assessment.

In case of doubt, consulting experts on this matter is highly recommended, considering that the risk analysis builds the basis of all further measures to be taken before the installation can be put into operation.

Analysis of the explosion protection risk

The user of a machine or installation has to perform an accurate analysis according to the standards EN 60079-10, EN 60079-14 and EN 1127-1. On the basis of this analysis, he has to classify the areas in which explosive atmospheres may be present into zones. These observations must be documented.

Documentation of the explosion protection

The documentation is essential to ensure a safe operation of the installation in the potentially explosive area. It is drawn up prior to the set-up and must always be kept up-to-date. In case of changes to the installation, all the described influences data must be taken into account.

Example of an explosion protection document

- Object responsible
- Called by name in the documentation
- Description of the structural/constructional and geographic conditions
- Layout plan, building map, plant ventilation system
- Description of the procedure, description of the plant with regard to explosion protection
- Substance characteristics, list of all data including explosion-relevant parameters
- Risk analysis, refer to checklist below
- Protection concept, zone classification, explosion protection types used
- Organisational measures
- Instructions, prescriptions in written, work authorisations



Classification of the potentially explosive areas into zones

To determine the necessary protective measures to be taken and to select appropriate equipment, the potentially explosive areas have to be classified into zones. This classification of the potentially explosive areas into zones is based upon the frequency and the duration of the presence of the dangerous explosive atmosphere.

These framework conditions (frequency, duration) determine the classification and identification of gas explosion risk areas as zone 0, 1 or 2 as well as the required measures to be taken in order to avoid active sources of ignition. Dust explosion risk areas are accordingly classified as zone 20, 21 or 22.

The EN 60079-10 standard can provide help with the classification of gas explosion risk areas into zones. The zone definition is included in all common documentation, i.e. in the ATEX Directive 1999/92/EC as well.

Zone 0 is an area, in which an explosive atmosphere consisting of a mixture with air of flammable substances in the form of gas, vapour or mist is present continuously or for long periods or frequently.

- Example: these conditions are usually found only inside containers, pipes, apparatus (evaporators, reaction chambers etc.).

Zone 1 is an area, in which an explosive atmosphere consisting of a mixture with air of flammable substances in the form of gas, vapour or mist is likely to occur occasionally in normal operation.

- Example: areas in the immediate surroundings of zone 0, of intakes and inlets, the areas around filling units and discharging equipment, the immediate surroundings of highly fragile apparatus or conductors in glass, ceramics etc., the area around insufficiently sealing gaskets, e.g. on pumps and dampers, the interior of apparatus such as evaporators and reaction chambers.

Zone 2 is an area, in which an explosive atmosphere consisting of a mixture with air of flammable substances in the form of gas, vapour or mist is not likely to occur in normal operation but, if it does occur, will persist for a short period only.

- Example: areas surrounding zone 0 or 1, specific storage plants

Zone 20 is an area, in which an explosive atmosphere in the form of a cloud of combustible dust in air is present continuously or for long periods or frequently.

- Example: these conditions are usually found only inside containers, pipes, apparatus, e.g. mills and grinders, dryers, mixers, feed pipes, silos etc.

Zone 21 is an area, in which an explosive atmosphere in the form of a cloud of combustible dust in air is likely to occur occasionally in normal operation.

- Example: also areas in the vicinity of inlets or work stations where dust is poured into containers, as well as areas where there are dust deposits and where a combustible dust/air mixture could form in the course of normal operation.

Zone 22 is an area, in which an explosive atmosphere in the form of combustible dust in air is not likely to occur in normal operation but, if it does occur, will persist for a short period only.

- Example: this could also include areas in the vicinity of devices containing dust, protection systems or components from which dust leaks and forms deposits (e.g. milling/grinding facilities, from which dust leaks and forms layers)

Dust Ex: selection according to the smouldering temperature and the ignition temperature

When selecting electrical apparatus for use in dust explosion risk areas, the smouldering temperature of the deposited dust and the ignition temperature of the potentially explosive dust/air mixture must be known, regardless of the zone.

The smouldering temperature is the lowest temperature of a hot surface on which a dust deposit of a defined thickness is ignited.

The ignition temperature of a dust cloud is the lowest temperature of a heated wall of an oven that ignites the dust/air mixture upon brief contact.

Combustible dusts are not divided into temperature classes like gases. The maximum surface temperature must be mentioned on the electrical equipment.

The table below summarizes the explosion parameters (ignition temperature, smouldering temperature and minimum ignition energy) of a few dusts.

Please note that for flammable substances a collective name, e.g. mill dust, designates different kinds of that product, each of them with diverging safety characteristics and parameters. Wheat flour for instance has other parameters than rye flour.

The specific parameters of the dust, which is permanent in each dust explosive area, must be determined. When the parameters of collective names are used, miscalculations can occur.

Substance	Ignition temperature Ti [°C]	Smouldering temperature Ts [°C]	Minimum energy Emin [mJ]
Flour	≥ 380	≥ 300	≥ 30
Wood	≥ 410	≥ 200	≥ 100
Brown coal	≥ 380	≥ 225	–
Coal	≥ 500	≥ 240	≥ 1000
PVC	≥ 530	≥ 340	≥ 5
Aluminium	≥ 560	≥ 270	≥ 5
Sulphur	≥ 240	≥ 250	10

The basics of explosion protection

60079-15
EN

Types of protection

General overview

Essential requirements

The EN 60079-0 describes the essential requirements, which apply to all types of explosion protection.

Mechanical protection

Mechanical tests are carried out in accordance with EN 60079-0. The enclosures or the exterior part of the enclosure, pushbuttons must withstand high impact energy.

Type of protection „n“ EN 60079-15

The type of protection “n” originally was used as stand-alone standard for use in ATEX category 3G respectively was defined as zone 2 standard in IECEx. This standard has been designed for normal operation. The fault analysis, which is performed for the other types of protection, is not executed, considering that the explosive atmosphere and the ignition spark are very unlikely to occur simultaneously in zone 2; in other words: electrical apparatus cannot ignite an explosive atmosphere surrounding them in normal operation and under defined abnormal operating conditions. Meanwhile, the EN 60079-15 has been rewritten, so that the essential requirements are now described in the EN 60079-0. This reflects for instance in the following way: The type of protection Ex nL has been replaced with the Ex ic type of protection relative to intrinsic safety. The sub-group is transferred from the EN 60079-15 into the EN 60079-11. This leads to changes, which could require a more accurate analysis.

Temperature classes for gases (EN 60079-0):

Classification of the maximum surface temperature into classes for electrical apparatus belonging to Equipment Group II

T1	T2	T2	T4	T5	T6
450°C	300°C	200°C	135°C	100°C	85°C

Ignition protection type and the main characteristics

Ignition protection type	Basic principle, main application
Oil immersion „o“	The source of ignition is permanently immersed in oil. Application: switchgear and transformers
Pressurized enclosures „p“	The formation of a potentially explosive atmosphere inside an enclosure is prevented by maintaining a positive internal pressure of protective gas in relation to the surrounding atmosphere. Application: machinery, commutation motors, control cabinets, monitors, keyboards, analysers
Powder filling „q“	A fine granular packing material surrounds the ignition source, thus making it impossible for an electric arc created in the enclosure under certain operating conditions to ignite a potentially explosive atmosphere surrounding the enclosure. Application: capacitors, condensers, electronic ballast, sensors
Flameproof enclosures „d“	Parts which can ignite a potentially explosive atmosphere are surrounded by an enclosure which withstands the pressure of an explosive mixture exploding inside the enclosure and prevents the transmission of the explosion to the atmosphere surrounding the enclosure. Application: switchgear, spark-generating parts, power engineering, heavy-current engineering
Increased safety „e“	Additional measures are applied to increase the level of safety, thus preventing the possibility of excessive temperatures and the occurrence of sparks or electric arcs within the enclosure or on exposed parts of electrical apparatus, where such ignition sources would not occur in normal service. Application: terminal and connection boxes (engines)
Encapsulation „m“	Parts that are capable of igniting an explosive atmosphere by either sparking or heating are enclosed in a compound in such way as to avoid ignition of an explosive atmosphere. Application: sensors, variable speed drives
Intrinsic safety „i“	An electric circuit is intrinsically safe if no sparks or thermal effects produced under specified test conditions are not capable of causing ignition of a given explosive atmosphere. Application: measurement and control technology
Intrinsically safe systems „i-SYST“	The entirety of interlinked and interconnected electrical apparatus, documented by a system description. Circuits used completely or partly inside hazardous areas are intrinsic safe.

Intrinsic safety

Principle

The type of protection "intrinsic safety" Ex i is based on the principle of limitation of current, voltage and storable energy within an electric circuit. Intrinsic safety does not reduce the potentially explosive substance and/or the oxidizing agent.

The ignition of an explosive mixture is avoided, when neither electric sparks nor the effect of heat can occur. The electrical energy is limited in order to keep electrical sparks below the ignition limit.

The energy limitation avoids the excessive heating of the electrical apparatus and its surfaces. This also applies to the sensors integrated in the intrinsically safe electrical circuits. Electrical energy can be stored in capacities (condensers) or inductivities (coils) within the intrinsically safe electrical circuit.

Zener diodes, which are used for limiting voltage, become conductive as of a specific voltage. The increased voltage is conducted

through the zener diode, i.e. the electrical circuit in the EX zone has limited voltage.

A series-wired resistance limits the current in the potentially explosive area.

$$I_{\max} = I_0 = U_0 / R$$

With the limitation of voltage and current, the maximum power is

$$P_0 = U_0^2 / 4R$$

The authorised maximum values are taken from the ignition limit curves, defined in the EN 60079-11 standard. For the gas groups I, IIA, IIB and IIC, there are four ignition limit curves. The classification is done according to the ignition energy.

The ignition limit curves have been calculated by means of a spark tester, as described in the EN 60079-11 standard.

Subdivision of the type of protection „n“ Ex n in Europe

Symbol	Meaning	Comparable with	Method	Subdivision
A	Non-sparking	Ex e	Occurrence of electric arcs, sparks or hot surfaces is minimised	None
C	Sparking apparatus	Partially Ex d, Ex m	Enclosed switching device, non-explosive components hermetically closed, sealed or encapsulated devices	IIA, IIB, IIC
R	Vapour-tight enclosure	–	Penetration of explosive gases is reduced	None
L*	Energy limitation	Ex i	Energy limitation, so that neither sparks nor thermal effects can produce an ignition	IIA, IIB, IIC
P	Simplified pressurized enclosure	Ex p	Penetration of explosive gases is avoided by overpressure. The monitoring unit will not switch-off	None

*different in North-America and Europe

The basics of explosion protection

EN 60079-11

Electrical apparatus and associated apparatus

An intrinsically safe electric circuit contains at least one electrical apparatus and one associated apparatus.

The electric circuits of the electrical apparatus meet the requirements of the intrinsic safety. The electrical apparatus must only be connected to non-intrinsically safe circuits through associated apparatus. An associated apparatus possesses both intrinsically safe and non-intrinsically safe circuits. To separate the electric circuits, a zener diode or galvanic isolators are used. The EN 60079-11 describes this separation calls as a "safety barrier". Intrinsically safe electrical apparatus and intrinsically safe components from associated equipment are classified in different levels of protection "ia", "ib" and "ic" according to EN 60079-11. This classification is included as of the 5th edition of the IEC Ex version.

The "ia" category basically offers the highest level of protection, "ib" a higher level of protection and "ic" a high level of protection. The category "ia" or "ib" determines whether the protective circuit offers a single fault safety or a double fault safety. For protection level "ic", no fault analysis is performed.

Here the safety for normal operation is sufficient. Therefore, the standard EN 60079-14, chapter 12.3 recommends galvanic isolation for intrinsically safe circuits in zone 0, category "ia". For intrinsic safety, a fault analysis is performed to exclude explosion risks. However, no statement whatsoever is made with regard to the operational safety. This means that a functional total breakdown is, for the explosion protection standpoint, allowed.

The electrical apparatus may be used in zone 0 in accordance with the category. The associated apparatus are installed in the safe area, only the intrinsically safe electric circuits are installed in the potentially explosive area in accordance with the category.

Basically it is possible to apply further protection measures. So that the associated apparatus can be installed in zone 2 or even in zone 1.

Design of intrinsically safe electric circuits

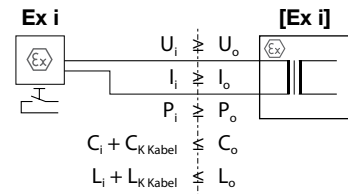

Design of intrinsically safe electric circuits (typical values)

Resistance (back/forth)	0.5 mm ²	72 Ohm/km
	0.75 mm ²	48 Ohm/km
	1.5 mm ²	24 Ohm/km
Capacity		180-200 nF/km
Inductivity		0,8-1 mH/km

Simple electrical apparatus – intrinsic safety

Type	Condition	Example
Passive components	None	Switches, terminal/junction boxes (modular enclosures), resistance, simple semi-conductor components
Energy storage	Values must be observed during calculation	Capacitors, coils
Energy source	≤ 1,5 V ≤ 100 mA ≤ 25 mW	Thermocouple Photocell



Cables for zones 0, 1 and 2

The cables must be laid in such manner that they are protected against mechanical damages, corrosion, chemical and thermal influences. This is an obligatory requirement for the type of protection "intrinsic safety". The accumulation of potentially explosive atmospheres must be prevented in shafts, pits, ducts, conduits and trenches.

The propagation of flammable gases, vapours, liquids or combustible dusts through shafts, pits, ducts, conduits and trenches must be prevented as well.

If possible, cables and conductors must be laid without interruption in the potentially explosive area. If this is impossible, the connection of cables must be realised in a junction box with the appropriate explosion protection type for that zone. If deviation of this stipulation is required for installation reasons, the requirements of the EN 60079-14 standard must be observed.

Appropriate cables must be selected for intrinsically safe electric circuits. Furthermore, the following conditions apply to intrinsically safe electric circuits, also when they are installed outside of the potentially explosive area:

- Protection against the ingress of external energy.
- Protection against external electric or magnetic fields.

Possible cause: overhead highvoltage line or 1-phase highvoltage lines.

- The conductors of intrinsically safe and non-intrinsically safe electric circuits must not be laid in the same conduit.
- In case of armoured, metal sheathed or shielded cables, intrinsically safe and non-intrinsically safe electric circuits can be laid in the same conduit.

In the control cabinet, the intrinsically safe electric circuits must be clearly marked. The standard prescribes no uniform procedure and only points out that for the marking preferably a light blue colour should be used. However, the neutral conductors of energy cables are usually also marked with a blue colour. In order to avoid confusion, another marking should be used for the intrinsically safe electric circuits in this case. What is important, is a conveniently arranged layout and a spatial separation in the control cabinet.

Conductive shields must only be earthed at places located outside the potentially explosive atmosphere.

Cable	Requirement	
Stationary apparatus	Enclosure	Thermoplastic, duroplast, elastomer or metal insulated with metal enclosure
Mobile, transportable apparatus	External enclosure	Heavy polychloroprene, synthetic elastomer, heavy rubber hose pipe or similar robust design
	Minimum section surface	1.0 mm ²
flexible	Design	<ul style="list-style-type: none"> – Light rubber hose pipe with/without polychloroprene enclosure – Heavy rubber hose pipe with/without polychloroprene enclosure – Plastic-insulated cable, similar to heavy rubber hose pipe

Selection criteria for cables for the type of protection "intrinsic safety"

Criterion	Condition	Note
Insulated cables	Test voltage ≥ 500 VAC	Cable ground, cable shield and shield ground
Diameter of the individual conductors	$\geq 0,1$ mm	Also for flexible conductors
Flexible conductors	To be protected against splicing	e.g. by using conductor ferrules
Multi-wire cables	Acceptable	The requirements for the error analysis to EN 60079-14 must be observed
Parameters	(Cc and Lc) or (Cc and Lc/Rc)	In case of doubt: worst case



Mechanical explosion protection

The general requirements can be summarised as follows:

- The equipment must meet all stipulated application requirements (e.g. rough operation, humidity effects, ambient temperature and pressure fluctuations, influence of chemical agents, corrosion, vibrations) (refer to the operating instructions);
- Determination and evaluation of the ignition hazards – Apparatus interior (heating due to failure capable of causing ignition inside the device) – Dust deposits (friction between moving parts) – Evaluation of the surface temperature according to the category
- Documentation of the ignition hazard analysis
- Determine the maximum surface temperature for internal and external surfaces (for category 1 maximum 80 % of T1 ... T6)
- Prevention of mechanically generated sparks by friction, stroke and grinding processes (aluminium, magnesium, titan and zirconium portion in alloys and coatings to be limited in accordance with the category); All conductive parts must be grounded and protected against sparks produced by static electricity; disruptive discharge voltage of non-conductive layers on metallic surfaces smaller than 4 kV; surface resistance smaller than 10^9 Ohm
- Further detailed requirements depending on the equipment category and possible sources of ignition.

The maximum authorised mass portions for the material used for external parts in case an ignition hazard is present due to friction, stroke or friction sparks according to the ignition hazard evaluation, amount to:

- Category M1/M2: not more than 15% aluminium, magnesium, titan and zirconium in total as well as not more than 6% magnesium, titan and zirconium in total
- Category 1: not more than 10 % aluminium, magnesium, titan and zirconium in total as well as not more than 7.5 % magnesium, titan and zirconium in total
- Category 2: not more than 7.5 % magnesium,
- Category 3: no special requirements.

EN 13463-1, clause 5.2 “Evaluation of the ignition hazard” requires an assessment of the ignition hazards as well as a corresponding report in tabular form (example: refer to page 13).

The ignition hazard assessment is used for the classification into equipment categories:

“If an equipment has been designed and built in accordance with good engineering practices and the assessment of the ignition hazards ensures that under normal operation, the equipment has no potential source of ignition, the equipment can be classified into the equipment category 3.

If the ignition hazard assessment ensures that the equipment has no potential source of ignition in case of expected or rare malfunctions, it can be classified into the equipment category 2 or 1”.

Section 5.2.7 of the EN 13463-1 includes an assessment report for Group II equipment.

Constructional safety „c“

- Type of protection, in which constructional measures are applied to ensure protection against potential ignition by hot surfaces, sparks and adiabatic compressions generated by moving parts,
- Using proven technical principles,
- The probability of a dangerous failure is very low
- Observations with regard to the lifetime of ball and rolling bearings, distances between moving and fixed parts, rotation speeds higher than 1 m/s, electrostatic problem for belt transmissions.

Marking

- Basic requirement: the field of application of all EX-relevant equipment, protective systems and components must be identified.
- Marking example: Ⓢ II 1G c T4

Conditions for safe operation

- The special conditions for a safe application are described in the operating instructions manual of the individual Ex safety switchgear.

Assessment of the ignition hazard for equipment of Group II (EN 13463-1), gas

Potential ignition source (1)			Measures applied to prevent the source becoming effective (2)	Ignition protection used (3)
Normal operation (1b)	Expected malfunction (1b)	Rare malfunction (1c)		

Columns (1b) and (1c) are only required, when the definition of the equipment category of Group II requires that they must be protected in case of specific malfunctions, e.g. for equipment category 2 or 1.
 The manufacturer of the equipment performs and documents the risk analysis of the ignition hazard. The user must also perform a risk analysis for the equipment, which was integrated in the machine at the time when it had to meet the requirements of the ATEX 1999/92/EC.

Product designation

Product designation																
1		2					3			4						
Ignition hazard																
a		b	a	b	c	d	e	a	b	c	a	b	c	d	e	f
No.	Potential ignition source		During normal operation	During expected malfunction	During rare malfunction	Not to be observed	Reasons for assessment	Description	Description of the protective measurement (standards, technical rules, experimental results)	Proof (including relevant Ex features listed in column 1)	During normal operation	During expected malfunction	During rare malfunction	Not to be observed	Resulting equipment category in respect of this ignition hazard	Necessary restrictions
1																
2																
3																
Resulting equipment category including all existing ignition hazards																

The basics of explosion protection

Safety relay modules



The safety relay modules of the PROTECT series SRB 101Exi (one safety release) and SRB 200Exi (two safety releases) are suitable for use in potentially explosive atmospheres or Ex zones. There are variants with monitored reset function (trailing edge) as well as with automatic or manual reset function. All these versions have a stop 0 safety release and optionally can be supplied with cross-wire short detection.

Content	
SRB 101EXi-...	16
SRB 200EXi-...	18

SRB-EXi safety relay module

PROTECT SRB 101EXi-...



- 1 or 2 channel control
- 1 safety contact
- Suitable for signal processing of emergency stop control devices, interlocking equipment, etc.
- 1 additional signalling contact (auxiliary contacts must not be used in safety circuits)
- Trailing edge (version -1R)
- Automatic reset function (version -1A)
- Optionally cross-wire short recognition (through switch)
- Current and voltage limitation of the input circuits (intrinsically safe)
- Green LED indications for relays K1, K2, U_B, U_i and U_{EXi}
- DIN rail mounting to DIN EN 60715:2001
- Thermoplastic enclosure to UL-94-V-0, graphitic black RAL 9011
- Certification to DIN EN ISO 13849-1:2007
- Certification to ATEX 94/9/EG
- Electric circuits up to zone 1/21
- Installation in zone 2 possible

Gas zone (1), 2 / Dust zone (21), 22

Technical data

Equipment category, explosion protection type:	Gas: Ⓜ II 3 G Ex nAnC IIC T5 (SRB in zone 2); Gas/dust: Ⓜ II (2) GD [Ex ib] IIC/[Ex ibD] [Ex ib] IIC/[Ex ibD]
Inputs (S11-S12, S21-S22, X1-X2/X3):	
Temperature class:	T5
Voltage U _o :	33.6 V
Current I _o :	57.0 mA
Capacity P _o :	478.8 mW (linear characteristic)
Maximum safety voltage U _m :	253 VAC
Isolation:	safe separation to EN 60079-11: Amplitude of the voltage 375 V
Rated operating voltage:	24 VDC -15%/+20%, residual ripple max. 10%
Recommended fuse for the operating voltage:	internal fuse F1: T 50 mA/250 V; internal fuse F2: T 100 mA/250 V
Protection class:	enclosure: IP40 Terminals: IP20 Wiring compartment: IP54
Power consumption:	max. 3.0 W
Switching capacity of the enabling paths:	230 V; 3 A ohmic (inductive with suitable protective circuit) AC-15: 230 VAC/3 A DC-13: 24 VDC/3 A
Recommended fuse for the enabling paths:	3.15 A slow blow
Min. switching capacity:	min. 10 V/10 mA
Contact resistance:	max. 100 mΩ in new state
Contact material/contacts:	AgSnO, self-cleaning, positive drive
Switching capacity of the auxiliary contacts (21-22):	24 VDC, 2 A
Recommended fuse for the auxiliary contacts:	2 A slow blow
Current and voltage at S11-S12, S21-S22:	24 VDC, 5 mA
Current limitation at S11-S12, S21-S22:	15 mA
Pull-in delay:	approx. 300 ms (Version -1A) approx. 20 ms (Version -1R)
Drop-out delay:	in case of emergency stop: approx. 20 ms; in case of voltage drop: approx. 20 ms
Bridging in case of voltage drops:	approx. 15 ms
Air clearances and creepage distances:	EN 60664-1:2003 (DIN VDE 0110-1), 4 kV/2; EN 60079-11:2007 (VDE 0170/0171 Part 7)
Max. total line resistance:	30 Ohm
Ambient operating:	-25 °C ... +60 °C
Storage temperature:	-40 °C ... +85 °C
EMV:	EN 61000-6-2:2005
Vibrations:	EN 60068-2-6:1996
Frequency:	10 ... 55 Hz
Amplitude:	0.35 mm
Climatic resistance:	EN 60068-2-3:1986
Mechanical life:	10 ⁷ operations
Weight:	230 g
Dimensions:	22.5 x 100 x 121 mm

Approvals



Ordering details

SRB 101EXi-1①

No.	Option	Description
①	R	Trailing edge
	A	Automatic reset function

Classification

Safety parameters:

Standards:	EN ISO 13849-1, IEC 61508, EN 60947-5-1
PL:	STOP 0: up to e
Category:	STOP 0: up to 4
PFH value:	STOP 0: ≤ 2.00 x 10 ⁻⁸ /h
SIL:	STOP 0: up to 3
Mission time:	20 years

The PFH value of 2.00 x 10⁻⁸/h applies to the combinations of contact load (current through enabling contacts) and number of switching cycles (n-op/y) mentioned in the table below. At 365 operating days per year and a 24-hours operation, this results in the below-mentioned switching cycle times (t-cycle) for the relay contacts. Diverging applications upon request.

Contact load	n-op/y	t-cycle
20 %	525,600	1.0 min
40 %	210,240	2.5 min
60 %	75,087	7.0 min
80 %	30,918	17.0 min
100 %	12,223	43.0 min

SRB-EXi safety relay module

Note

- 2-channel control, shown for a guard door monitor with two position switches where one has a positive break contact; with external reset button (R).
- Relay outputs: 2-channel control, suitable for contact reinforcement or multiplication by means of contactors or relays with positive-drive contacts.
- (H2) = Feedback circuit
- The control recognizes cable break, cross-wire shorts (switch in position "QS") and earth leakages in the monitoring circuit.
- The safety function is defined as the opening of release 13-14 when the inputs S11-S12 or S21-S22 are opened.

Wiring diagram

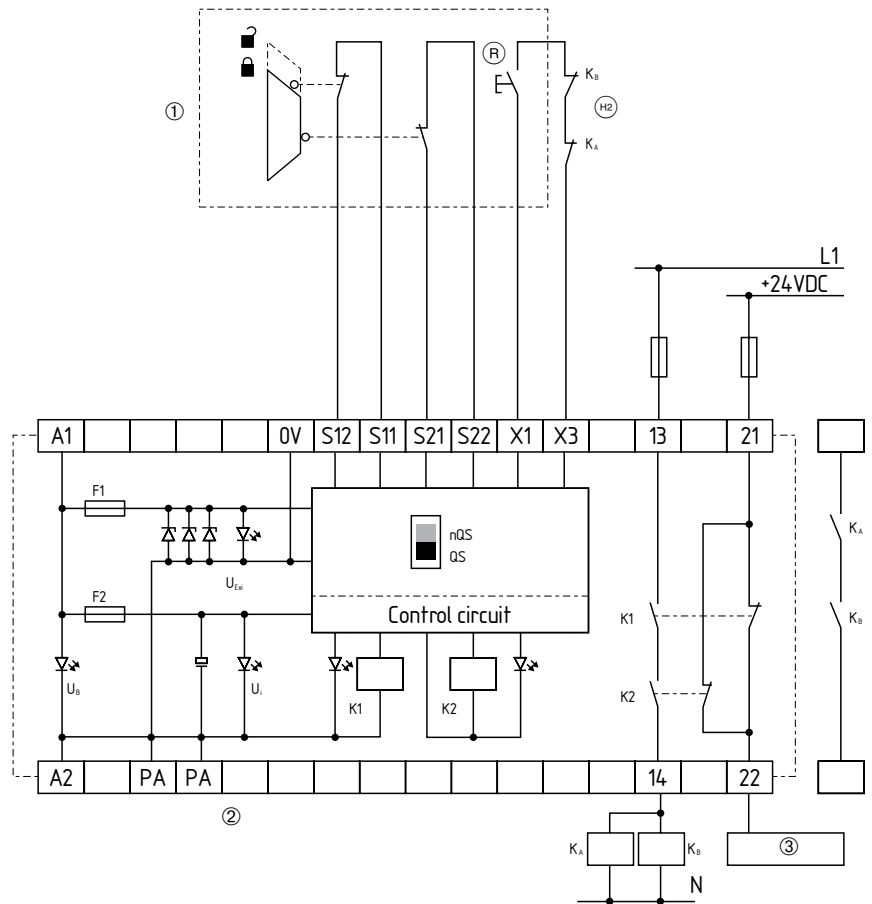

Gas zone (1), 2 / Dust zone (21), 22

Note

- Cable connections:
single strand: rigid or flexible (with or without conductor ferrules) 0.25 ... 2.5 mm²;
multi-strand with identical section:
rigid or flexible (with conductor ferrules without plastic) 0.25 ... 2.5 mm²;
flexible (without or with TWIN conductor ferrules) 0.5 ... 1.5 mm²

Legend

- ① Sensor: Installation in zone 1/21
- ② SRB EXi: Installation in zone 2
- ③ Control

SRB-EXi safety relay module

PROTECT SRB 200EXi-...



- 1 or 2 channel control
- 2 safety contacts
- Suitable for signal processing of emergency stop control devices, interlocking equipment, etc.
- Trailing edge (version -1R)
- Automatic reset function (version -1A)
- Optionally cross-wire short recognition (through switch)
- Current and voltage limitation of the input circuits (intrinsically safe)
- Green LED indications for relays K1, K2, U_B, U_i and U_{EXi}
- DIN rail mounting to DIN EN 60715:2001
- Thermoplastic enclosure to UL-94-V-0, graphite black RAL 9011
- Certification to DIN EN ISO 13849-1:2007
- Certification to ATEX 94/9/EG
- Electric circuits up to zone 1/21
- Installation in zone 2 possible

Gas zone (1), 2 / Dust zone (21), 22

Technical data

Equipment category, explosion protection type:	Gas: Ⓜ II 3 G Ex nAnC IIC T5 (SRB in zone 2) Gas/dust: Ⓜ II (2) GD [Ex ib] IIC/[Ex ibD] [Ex ib] IIC/[Ex ibD]
Inputs (S11-S12, S21-S22, X1-X2/X3):	T5
Temperature class:	T5
Voltage U _o :	33.6 V
Current I _o :	57.0 mA
Capacity P _o :	478.8 mW (linear characteristic)
Maximum safety voltage U _m :	253 VAC
Isolation:	safe separation to EN 60079-11: Amplitude of the voltage 375 V
Rated operating voltage:	24 VDC -15%/+20%, residual ripple max. 10%
Recommended fuse for the operating voltage:	internal fuse F1: T 50 mA/250 V; internal fuse F2: T 100 mA/250 V
Protection class:	enclosure: IP40 Terminals: IP20 Wiring compartment: IP54
Power consumption:	max. 3.0 W
Switching capacity of the enabling paths:	230 V; 3 A ohmic (inductive with suitable protective circuit) AC-15: 230 VAC/3 A DC-13: 24 VDC/3 A
Recommended fuse for the enabling paths:	3.15 A slow blow
Min. switching capacity:	min. 10 V/10 mA
Contact resistance:	max. 100 mΩ in new state
Contact material/contacts:	AgSnO, self-cleaning, positive drive
Current and voltage at S11-S12, S21-S22:	24 VDC, 5 mA
Current limitation at S11-S12, S21-S22:	15 mA
Pull-in delay:	approx. 300 ms (Version -1A) approx. 20 ms (Version -1R)
Drop-out delay:	in case of emergency stop: approx. 20 ms; in case of voltage drop: approx. 20 ms
Bridging in case of voltage drops:	approx. 15 ms
Air clearances and creepage distances:	EN 60664-1:2003 (DIN VDE 0110-1), 4 kV/2; EN 60079-11:2007 (VDE 0170/0171 Part 7)
Max. total line resistance:	30 Ohm
Ambient operating:	-25 °C ... +60 °C
Storage temperature:	-40 °C ... +85 °C
EMV:	EN 61000-6-2:2005
Vibrations:	EN 60068-2-6:1996
Frequency:	10 ... 55 Hz
Amplitude:	0.35 mm
Climatic resistance:	EN 60068-2-3:1986
Mechanical life:	10 ⁷ operations
Weight:	230 g
Dimensions:	22.5 x 100 x 121 mm

Approvals



Ordering details

SRB 200EXi-1①

No.	Option	Description
①	R	Trailing edge
	A	Automatic reset function

Classification

Safety parameters:

Standards:	EN ISO 13849-1, IEC 61508, EN 60947-5-1
PL:	STOP 0: up to e
Category:	STOP 0: up to 4
PFH value:	STOP 0: ≤ 2.00 x 10 ⁻⁸ /h
SIL:	STOP 0: up to 3
Mission time:	20 years

The PFH value of 2.00 x 10⁻⁸/h applies to the combinations of contact load (current through enabling contacts) and number of switching cycles (n-op/y) mentioned in the table below. At 365 operating days per year and a 24-hours operation, this results in the below-mentioned switching cycle times (t-cycle) for the relay contacts. Diverging applications upon request.

Contact load	n-op/y	t-cycle
20 %	525,600	1.0 min
40 %	210,240	2.5 min
60 %	75,087	7.0 min
80 %	30,918	17.0 min
100 %	12,223	43.0 min

SRB-EXi safety relay module

Note

- 2-channel control, shown for a guard door monitor with two position switches where one has a positive break contact; with external reset button (R).
- Relay outputs: 2-channel control, suitable for contact reinforcement or multiplication by means of contactors or relays with positive-drive contacts.
- (H2) = Feedback circuit
- The control recognizes cable break, cross-wire shorts (switch in position "QS") and earth leakages in the monitoring circuit.
- The safety function is defined as the opening of release 13-14 when the inputs S11-S12 or S21-S22 are opened.

Wiring diagram

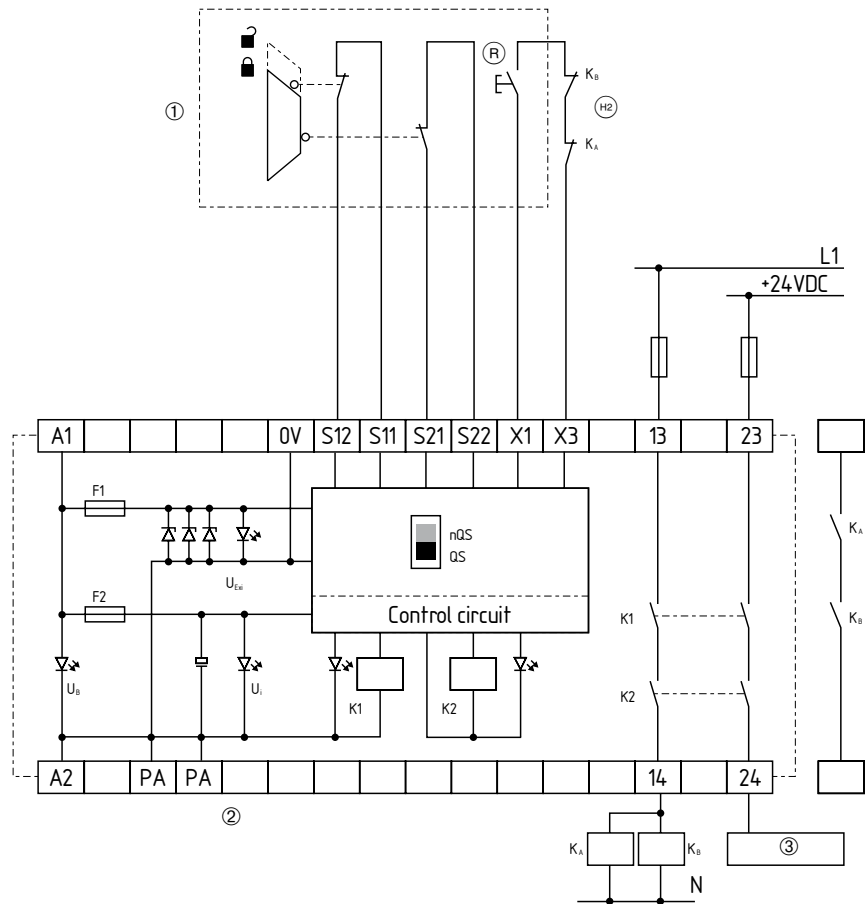

Gas zone (1), 2 / Dust zone (21), 22

Note

- Cable connections:
 single strand: rigid or flexible (with or without conductor ferrules) 0.25 ... 2.5 mm²;
 multi-strand with identical section:
 rigid or flexible (with conductor ferrules without plastic) 0.25 ... 2.5 mm²;
 flexible (without or with TWIN conductor ferrules) 0.5 ... 1.5 mm²

Legend

- ① Sensor: Installation in zone 1/21
- ② SRB Exi: Installation in zone 2
- ③ Control

Simple electric apparatus, type of protection “intrinsic safety”

For the classification of the protection type "intrinsic safety", an assessment of simple electrical apparatus to EN 60079-11 and EN 61241-11 must be executed.

As simple electrical apparatus within the meaning of intrinsic safety do not represent a potential source of ignition, the Directive 94/9/EC is not applicable. To demonstrate the intrinsic safety to EN 60079-14, a declaration of the manufacturer therefore can be used.

The devices classified as simple electrical apparatus can be used in the Zones 1 / 2 and 21 / 22.

On the basis of a valid declaration of the manufacturer with an assessment as simple electrical apparatus, the following devices can be used:

Series	Switch	Page
Safety switch	EX-AZ 16-...-3D	22
	EX-AZ 335-...-3D	25
	EX-AZ 355-...-3D	26
	EX-AZ 415-...-3D	28
	EX-AZ 3350-...-3D	30
Position switches	EX-Z/T 235-...-3D	44
	EX-Z/T 335-...-3D	54
Safety sensors	EX-BNS 33-...-3G/D, however without LED	94
	EX-BNS 120-...-3G/D, however without LED	96
	EX-BNS 180-...-3G/D	98
	EX-BNS 303-...-3G/D, however without LED	100
Magnetic reed switches	EX-BN 20-...-3G/D	106
Reset buttons	Ex-RDT	114
	Ex-RDM	114
Emergency stop control devices	Ex-RDRZ45	118

Safety switch with separate actuator

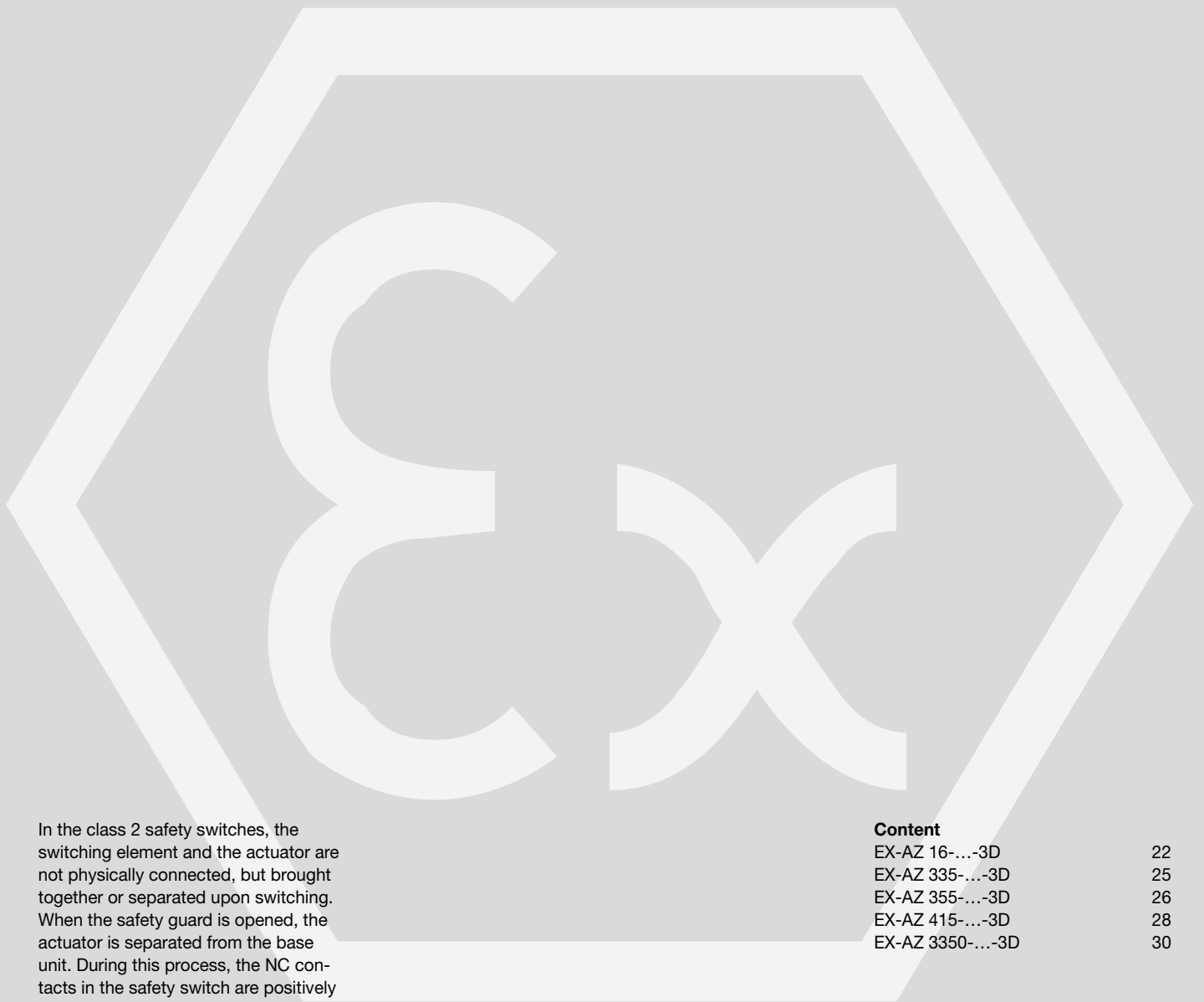

In the class 2 safety switches, the switching element and the actuator are not physically connected, but brought together or separated upon switching. When the safety guard is opened, the actuator is separated from the base unit. During this process, the NC contacts in the safety switch are positively opened and the NO contacts closed.

Content	
EX-AZ 16-...-3D	22
EX-AZ 335-...-3D	25
EX-AZ 355-...-3D	26
EX-AZ 415-...-3D	28
EX-AZ 3350-...-3D	30

Safety switch with separate actuator

EX-AZ 16-...-3D

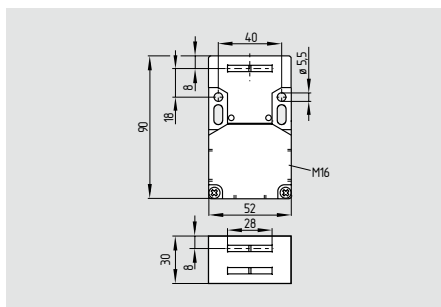

- Ex certified
- Thermoplastic enclosure
- Multiple coding
- Long life
- Double insulated X
- 3 cable entries M16
- Large wiring compartment
- High level of contact reliability with low voltages and currents
- Not sensitive to dirty conditions by virtue of patented roller system
- Slotted holes for adjustment, circular holes for location
- Including Ex-certified screwed cable gland and screw plug

Technical data

Equipment category: II 3D
 Ex protection: Ex tD A22 IP67 T90°C X
 Standards: EN 60947-5-1
 EN 61241-0
 EN 61241-1
 BG-GS-ET-15
 Enclosure: glass-fibre reinforced thermo-plastic, self-extinguishing
 Max. impact energy: 1 J
 Actuating speed: max. 1 m/s
 Actuator: stainless steel 1.4301
 Protection class: IP67 to EN 60529
 Contact material: Silver
 Contact type: change-over contact with double break, type Zb or 3 NC contacts, with galvanically separated contact bridges
 Switching system: \ominus IEC 60947-5-1 slow action, NC contact with positive break
 Connection: screw terminals
 Cable section: max. 2.5 mm² (incl. conductor ferrules)
 Cable entry: 3 x M16
 U_{imp} : 6 kV
 U_i : 500 V
 I_{the} : 2.5 A
 Utilisation category: AC-15 DC-13
 I_e/U_e : 2.5 A / 230 VAC
 2.5 A / 24 VDC
 Max. fuse rating: 4 A gG D-fuse
 Positive break travel: 8 mm
 Positive break force: 10 N for each
 Ambient temperature: - 20 °C ... + 70 °C
 Mechanical life: > 1 million operations
 Latching force: 30 N for ordering suffix R
 Cable cross-section of the cable glands: min. \varnothing 5 mm
 max. \varnothing 10 mm
 II 2D

Contact variants

1 NO / 2 NC



3 NC contacts



Dust zone 22

Approvals



Ordering details

EX-AZ16-①ZV②K-③-3D

No.	Option	Description
①	03	3 NC contact
	12	1NO/2NC contacts
②		Ejection force
	R	Latching force 30 N
③	2254	Latching force 5 N
	1762	Front mounting
	1637	Gold-plated contacts

Note

Actuators must be ordered separately.

Safety switch with separate actuator

System components

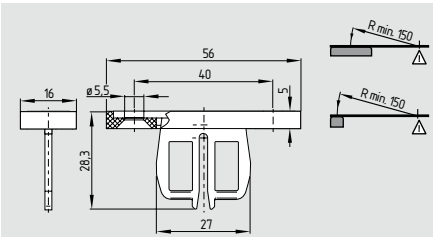

Straight actuator B1

System components

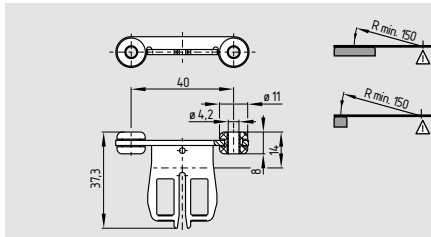

With rubber mounting B1-2245

System components

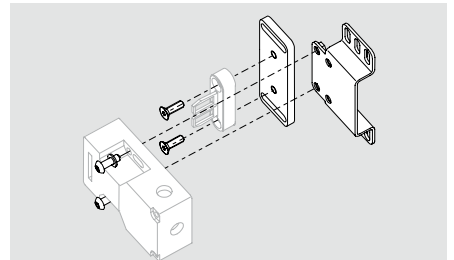

Mounting set MS AZ 15/16

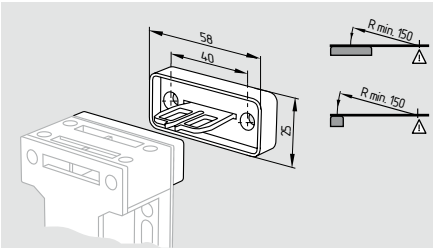

Actuator B1-2024 with slot lip-seal

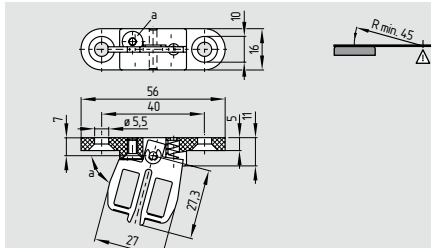

Flexible actuator B2

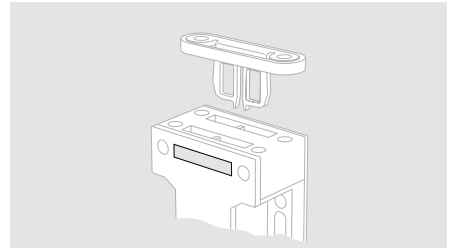

Slot sealing plug AZ 15/16-1476

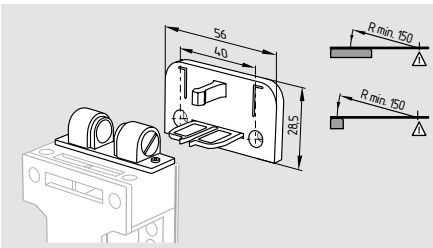

Actuator B1-2053 with ball latch

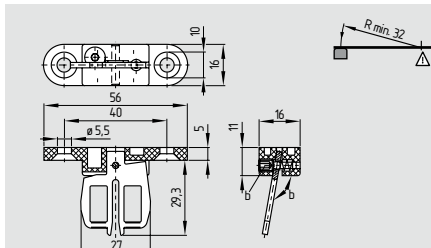

Flexible actuator B3

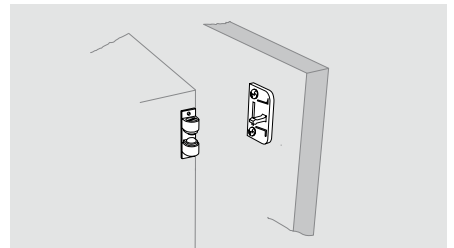

Ball catch 2053-2

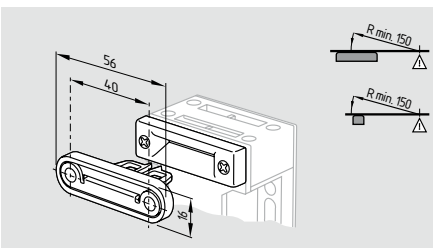

Actuator B1-2177 with centering guide

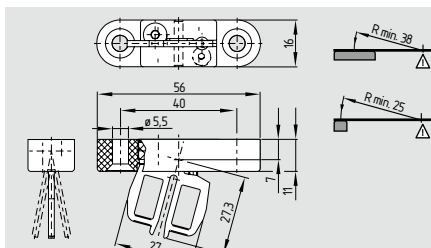

Flexible actuator B6

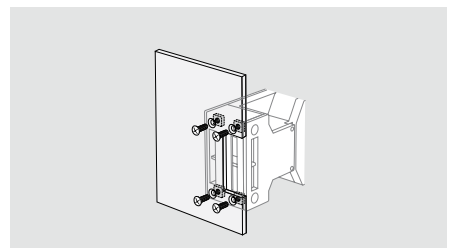

Front mounting -1762

Ordering details

Straight actuator **AZ 15/16-B1**
 with slot lip-seal **AZ 15/16-B1-2024**
 with ball latch **AZ 15/16-B1-2053**
 with centering guide **AZ 15/16-B1-2177**

Ordering details

Straight actuator **AZ 15/16-B1-2245**
 Flexible actuator **AZ 15/16-B2**
 Flexible actuator **AZ 15/16-B3**
 Flexible actuator **AZ 15/16-B6**

Ordering details

Mounting set **MS AZ 15/16**
 Slot sealing plug **AZ 15/16-1476**
 Ball catch **-2053-2**
 Front mounting with M5 nuts **-1762**

Safety switch with separate actuator

System components



Tamperproof screws

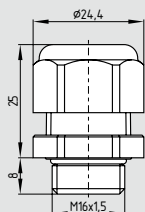

EX-certified screwed cable gland

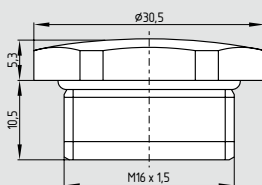

EX-certified screw plug

Dust zone 22

Ordering details

Tamperproof screws

M5 x 12 **101135338**

M5 x 16 **101135339**

M5 x 20 **101135340**

(Quantity 2 pcs)

EX-certified

screwed cable gland **EX-KLE-M16x1.5**

EX-certified

screw plug **EX-VS-M16x1.5**

Safety switch with separate actuator

EX-AZ 335-...-3D

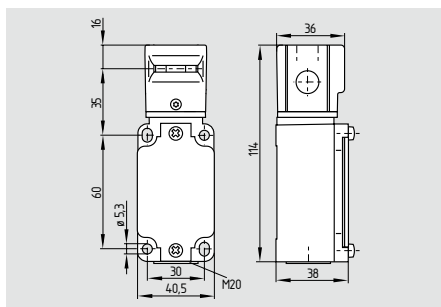

- Ex certified
- Metal enclosure
- 3 contacts
- Long life
- High level of contact reliability with low voltages and currents
- Mounting details to EN 50041
- Actuator heads can be repositioned in steps 4 x 90°
- Can be mounted on a flat surface
- Slotted holes for adjustment, circular holes for location
- 1 Cable entry M20
- Including Ex-certified screwed cable gland

Technical data

Equipment category: II 3D
 Ex protection: Ex tD A22 IP67 T90°C X
 Standards: EN 60947-5-1
 EN 61241-0
 EN 61241-1
 BG-GS-ET-15

Enclosure: light-alloy diecast, paint finish
 Actuator: stainless steel 1.4301
 Max. impact energy: 4 J
 Actuating speed: max. 1 m/s
 Protection class: IP67 to EN 60529
 Contact material: Silver
 Contact type: change-over with double break Zb, or 3 NC contacts, galvanically separated contact bridges

Switching system: I IEC 60947-5-1
 slow action, NC contact with positive break

Connection: screw terminals
 Cable section: max. 2.5 mm², min. 0.75 mm² (incl. conductor ferrules)

Cable entry: M20
 U_{imp} : 4 kV
 U_i : 250 V
 I_{the} : 10 A
 Utilisation category: AC-15, DC-13
 I_e/U_e : 4 A / 230 VAC
 4 A / 24 VDC

Max. fuse rating: 6 A gG D-fuse
 Positive break travel: 10.7 mm
 Positive break force: 5 N for each
 Ambient temperature: -20 °C ... +60 °C
 Mechanical life: 10 million operations
 Latching force: 30 N for ordering suffix R
 Cable cross-section of the cable glands: min. Ø 7 mm
 max. Ø 12 mm
 II 2D

Contact variants

1 NO / 2 NC
 13-14
 21-22
 31-32

3 NC contacts
 11-12
 21-22
 31-32

Approvals



Ordering details

EX-AZ 335-①-z②k-③-3D

No.	Option	Description
①	03	3 NC contact
	12	1NO/2NC contacts
②	R	Latching force 5 N
	UE	Latching force 30 N
		With overlapping contacts
③	1637	Gold-plated contacts

Note

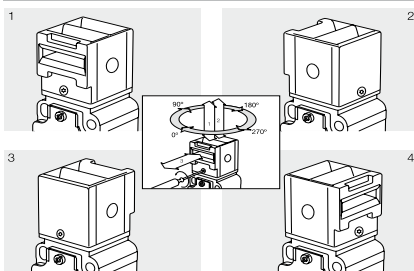

By turning the head in 90° steps, 8 actuating planes are possible. A Torx T10 screwdriver is required for this purpose.

Note

Actuators must be ordered separately.

Safety switch with separate actuator

EX-AZ 355-...-3D

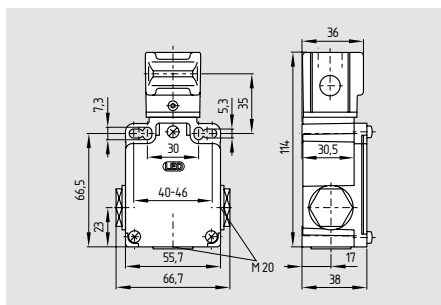

- Ex certified
- Metal enclosure
- 3 contacts
- Long life
- High level of contact reliability with low voltages and currents
- Mounting details to EN 50041
- Actuator heads can be repositioned in steps 4 x 90°
- Can be mounted on a flat surface
- Transverse and longitudinal slotted holes
- 3 cable entries M20
- Including Ex-certified screwed cable gland and screw plug

Technical data

Equipment category: II 3D
 Ex protection: Ex tD A22 IP67 T90°C X
 Standards: EN 60947-5-1
 EN 61241-0
 EN 61241-1
 BG-GS-ET-15

Enclosure: light-alloy diecast, paint finish
 Actuator: stainless steel 1.4301
 Max. impact energy: 1 J
 Actuating speed: max. 1 m/s
 Protection class: IP67 to EN 60529
 Contact material: Silver
 Contact type: change-over contact with double break, type Zb or 3 NC contacts, with galvanically separated contact bridges

Switching system: \ominus IEC 60947-5-1
 slow action, NC contact with positive break

Connection: screw terminals
 Cable section: max. 2.5 mm², min. 0.75 mm² (incl. conductor ferrules)

Cable entry: 3 x M20
 U_{imp} : 4 kV
 U_i : 250 V
 I_{the} : 10 A
 Utilisation category: AC-15, DC-13
 I_e/U_e : 4 A / 230 VAC; 4 A / 24 VDC

Max. fuse rating: 6 A gG D-fuse
 Positive break travel: 10.7 mm
 Positive break force: 5 N for each
 Ambient temperature: -20 °C ... +60 °C
 Mechanical life: 10 million operations
 Latching force: 30 N for ordering suffix R
 Cable cross-section of the cable glands: min. \varnothing 7 mm
 max. \varnothing 12 mm
 II 2D

Contact variants

1 NO / 2 NC

3 NC contacts

Dust zone 22

Approvals



Ordering details

EX-AZ 355-①-Z②K-③-3D

No.	Option	Description
①	03	3 NC contact
	12	1NO/2NC contacts
②	R	Latching force 5 N
	UE	Latching force 30 N
		With overlapping contacts
③	1637	Gold-plated contacts

Note

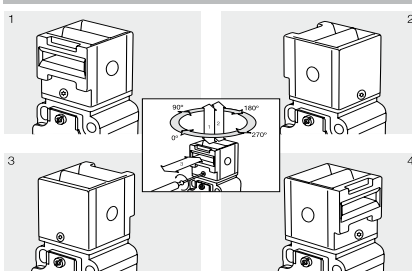

Actuators must be ordered separately.

By turning the head in 90° steps, 8 actuating planes are possible. A Torx T10 screwdriver is required for this purpose.

Safety switch with separate actuator

System components

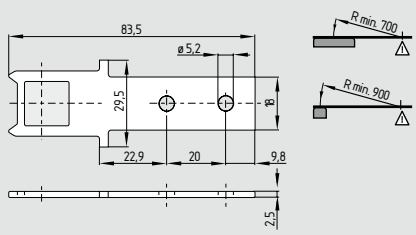

Straight actuator B1

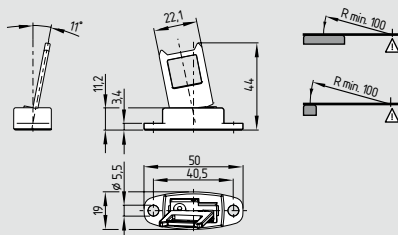

Flexible actuator B6

System components

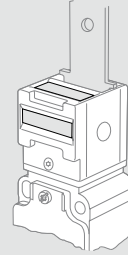

Slot sealing plug AZ 335/355-1990

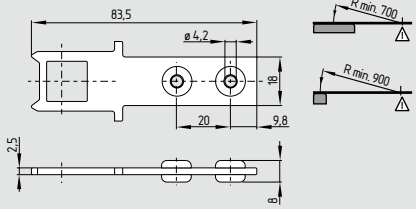

With rubber mountings B1-2245

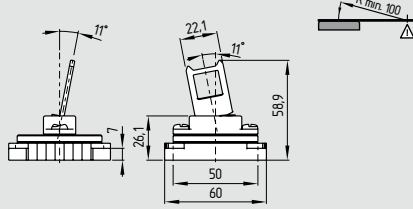

Flexible actuator B6-Flex

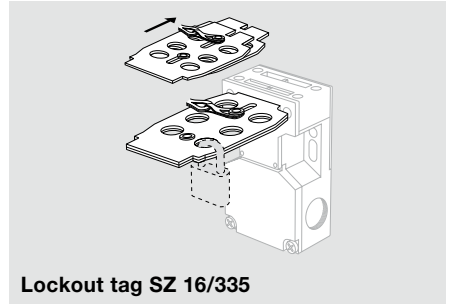

Lockout tag SZ 16/335

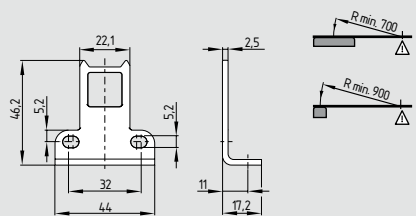

Angled actuator B5

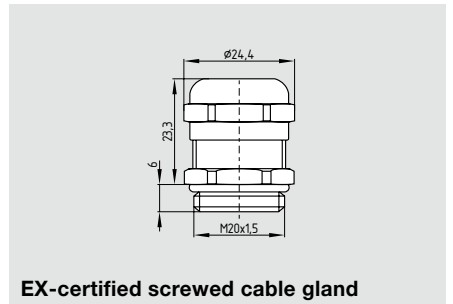

EX-certified screwed cable gland

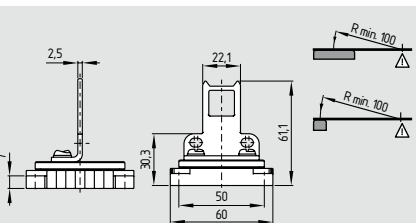

Angled actuator B5-Flex

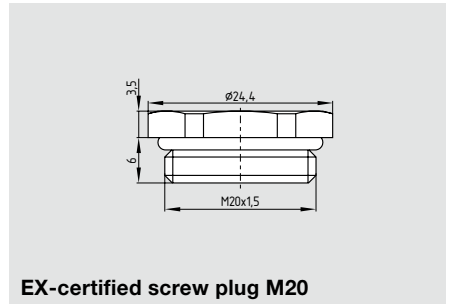

EX-certified screw plug M20

Ordering details

Straight actuator **AZ 335/355-B1**
 with rubber mounting **AZ 335/355-B1-2245**
 Angled actuator **AZ 335/355-B5**
 Angled actuator **AZ 335/355-B5-Flex**

Ordering details

Flexible actuator **AZ 335/355-B6**
 Flexible actuator **AZ 335/355-B6-Flex**

Ordering details

Slot sealing plug **AZ 335/355-1990**
 Lockout tag **SZ 16/335**

EX-certified
 screwed cable gland **EX-KLE-M20x1.5**
 EX-certified
 screw plug **EX-VS-M20x1.5**

Safety switch with separate actuator

EX-AZ 415-...-3D

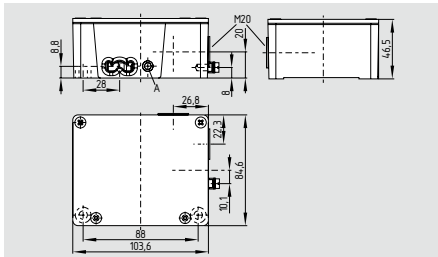

A: setting screw ball latch 30 - 500 N

- Ex certified
- Metal enclosure
- 2 switches with different actuating functions in a single enclosure
- Long life
- High level of contact reliability with low voltages and currents
- Adjustable ball latch to 500 N
- Spring-loaded actuators
- 2 cable entries M20
- Including Ex-certified screwed cable gland and screw plug

Technical data

Equipment category: II 3D
 Ex protection: Ex tD A22 IP67 T60°C X
 Standards: EN 60947-5-1
 EN 61241-0
 EN 61241-1
 BG-GS-ET-15
 Enclosure: light-alloy diecast, paint finish
 Max. impact energy: 4 J
 Actuating speed: max. 1 m/s
 Actuator: zinc-plated brass / aluminium
 Protection class: IP67 to EN 60529
 Contact material: Silver
 Contact type: change-over contact with double break, type Zb or 2 NC contacts, with galvanically separated contact bridges
 Switching system: \ominus IEC 60947-5-1 slow action, NC contact with positive break
 Connection: screw terminals
 Cable section: max. 1.5 mm²
 min. 0.75 mm²
 (incl. conductor ferrules)
 Cable entry: 2 x M20
 U_{imp} : 4 kV
 U_i : 250 V
 I_{the} : 6 A
 Utilisation category: AC-15, DC-13
 I_e/U_e : 4 A / 230 VAC
 4 A / 24 VDC
 Max. fuse rating: 6 A gG D-fuse
 Positive break travel: 3.8 mm
 Positive break force: min. 31 N
 Ambient temperature: -10 °C ... +50 °C
 Mechanical life: > 1 million operations
 Latching force: 30 - 500 N (adjustable)
 Cable cross-section of the cable glands: min. \varnothing 7 mm
 max. \varnothing 12 mm
 II 2D

Contact variants

11/11 1 NO contact / 1 NC contact
 1 NO contact / 1 NC contact

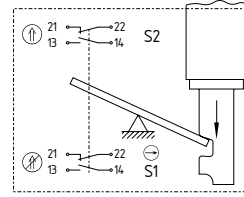

02/11 2 NC contacts
 1 NO contact / 1 NC contact

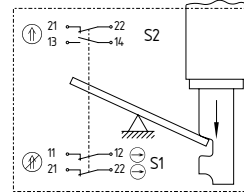

02/20 2 NO contacts
 2 NC contacts

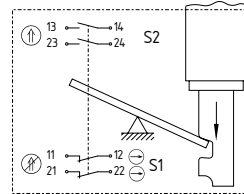

02/02 2 NC contacts
 2 NC contacts

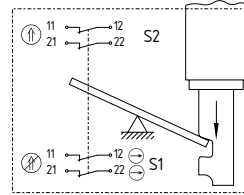

Approvals



Ordering details

Ex-AZ 415-①ZPK-②-3D

No.	Option	Description
-----	--------	-------------

①	S1 / S2	
11/11	1NO 1NC	/ 1NO 1NC contact
02/11	2NC	/ 1NO 1NC contact
02/20	2NC	/ 2NO contact
02/02	2NC	/ 2NC contact
②	1637	Gold-plated contacts

Note

Actuators must be ordered separately.

Note

Contact symbols shown for the closed condition of the guard device.

Safety switch with separate actuator

System components

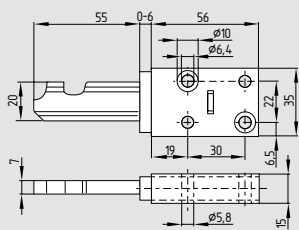

Straight actuator B1

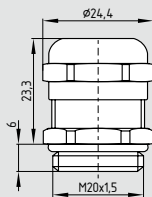

EX-certified screwed cable gland

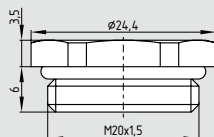

EX-certified screw plug M20

Ordering details

Straight actuator **AZ/AZM 415-B1**

EX-certified
screwed cable gland **EX-KLE-M20x1.5**

EX-certified
screw plug **EX-VS-M20x1.5**

Safety switch with separate actuator

EX-AZ 3350-...-3D

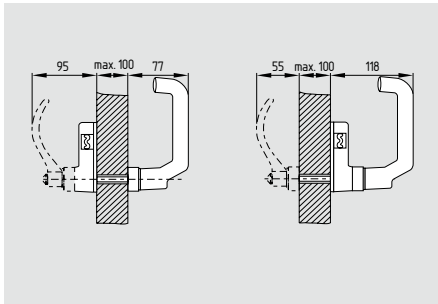

- Ex certified
- Metal enclosure
- Long life
- High level of contact reliability with low voltages and currents
- Shearing force 15,000 N
- Door handle latching
- Lockout tag against unintentional locking available
- Centring device available
- 1 Cable entry M20
- Including Ex-certified screwed cable gland
- Actuating head:

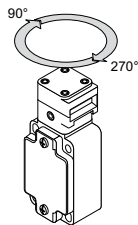

Approvals



Ordering details

EX-AZ 3350-①-②-③-3D

No.	Option	Description
①	03-ZK	3 NC contact
	12-ZUEK	1NO/2NC contacts
②	1637	Gold-plated contacts
③	U90	Actuating head 90° rotation Door hinge on the left-hand side
	U270	270° rotation Door hinge on the right-hand side

Technical data

Equipment category: II 3D
 Ex protection: Ex tD A22 IP67 T90°C X
 Standards: EN 60947-5-1
 EN 61241-0
 EN 61241-1
 BG-GS-ET-15
 Enclosure: light-alloy diecast, paint finish
 Max. impact energy: 4 J
 Actuating speed: max. 1 m/s
 Actuator: brass, blue chrome-plated
 Protection class: IP67 to EN 60529
 Contact material: Silver
 Contact type: change-over
 with double break Zb,
 or 3 NC contacts, galvanically
 separated contact bridges
 Switching system: IEC 60947-5-1 ,
 BG-GS-ET-15, slow action,
 NC contact with positive break
 Connection: screw terminals
 Cable section: max. 1.5 mm²
 (incl. conductor ferrules)
 Cable entry: 1 x M20
 U_{imp} : 4 kV
 U_i : 250 V
 I_{the} : 10 A
 Utilisation category: AC-15, DC-13
 I_e/U_e : 4 A / 230 V
 4 A / 24 VDC
 Max. fuse rating: 6 A gG D-fuse
 Positive break travel: 10.7 mm
 Positive break force: 5 N for each
 Ambient temperature:
 Mechanical life: 1 million operations
 Cable cross-section
 min. Ø 7 mm
 max. Ø 12 mm
 II 2D

EX-AZ 3350-ST30-...

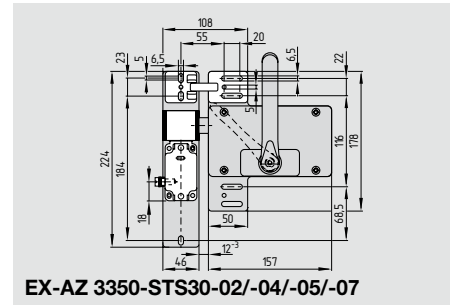

EX-AZ 3350-ST30-02/-04/-05/-07

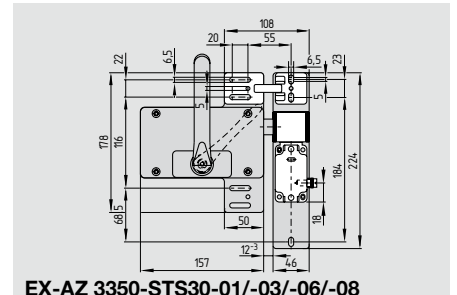

EX-AZ 3350-ST30-01/-03/-06/-08

Note

Included in delivery

- Mounting plate for safety switch
- Actuator incl. mounting plate
- Emergency handle (For variant -05 and -06 incl. mounting plate)

Ordering example

To order, first choose the desired safety switch and then the door handle system:
 for example EX-AZ 3350-12-ZUEK-U90 and
 EX-AZ 3350-ST30-02

Ordering details

The drawings are always shown with a view to the switch.

When the TF. centering device is used, the maximum actuating speed for closing the safety guard is limited to 1 m/s.

Safety switch with separate actuator

System variants

EX-AZ 3350-ST30-01

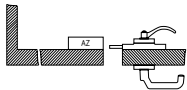

EX-AZ 3350-ST30-01

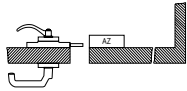

EX-AZ 3350-ST30-03

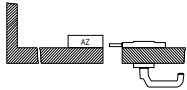

EX-AZ 3350-ST30-04

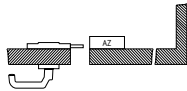

EX-AZ 3350-ST30-05

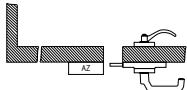

EX-AZ 3350-ST30-06

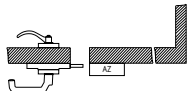

EX-AZ 3350-ST30-07

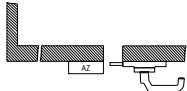

EX-AZ 3350-ST30-08

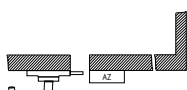

In all images, the guard door opens outwards.

System components

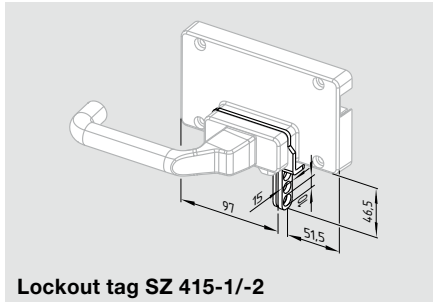

Lockout tag SZ 415-1/-2

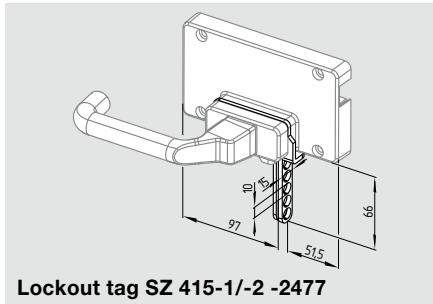

Lockout tag SZ 415-1/-2 -2477

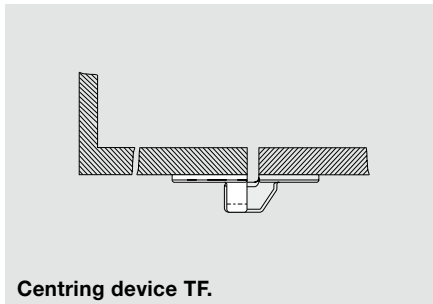

Centring device TF.

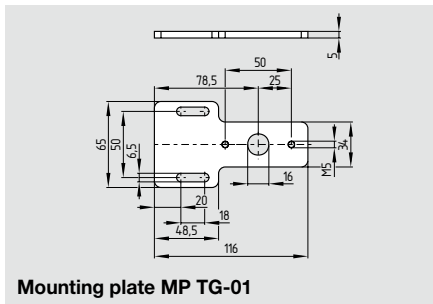

Mounting plate MP TG-01

System components

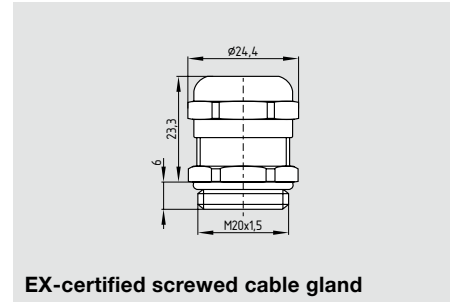

EX-certified screwed cable gland

Ordering details

Mounting inside with emergency handle

Door hinge right **EX-AZ 3350-ST30-01**

Door hinge left **EX-AZ 3350-ST30-01**

without emergency handle

Door hinge right **EX-AZ 3350-ST30-03**

Door hinge left **EX-AZ 3350-ST30-04**

Mounting outside with emergency handle

Door hinge right **EX-AZ 3350-ST30-05**

Door hinge left **EX-AZ 3350-ST30-06**

without emergency handle

Door hinge right **EX-AZ 3350-ST30-06**

Door hinge left **EX-AZ 3350-ST30-08**

Ordering details

Lockout tag

for ...ST30-01/-03/-06/-08 **SZ 415-1**

for ...ST30-02/-04/-05/-07 **SZ 415-2**

Lockout tag with 5 bore holes

for ...ST30-01/-03/-06/-08 **SZ 415-1-2177**

for ...ST30-02/-04/-05/-07 **SZ 415-2-2177**

Centering device:

Mounting outside **TFA-010**

Mounting inside **TFI-010**

For product information and dimensions, please refer to the Main Catalogue "Safety Technology".

Mounting plate **MP TG-01**

Ordering details

EX-certified

screwed cable gland

EX-KLE-M20x1.5

More Details



Detailed technical information at:
www.schmersal.com

Solenoid interlocks



In the solenoid interlocks of the EX-AZM series, the switching element with interlocking device and the actuator are not physically connected, but brought together or separated upon switching. When the safety guard is opened in the unlocked condition, the actuator is separated from the base unit. During this process, the NC contacts are positively opened and the NO contacts closed. Interlocking is carried out by means of a blocking bolt / latching bolt. This latching bolt blocks the actuator so that it cannot be withdrawn from the interlock. The machine control is only enabled when the actuator has been inserted into the interlock and the latching bolt is in the blocking position. This is ensured by the contact monitoring of the latching bolt.

Content

EX-AZM 170-...-3G/D	34
EX-AZM 161-...-3D	36
EX-AZM 415-...-3D	40

Solenoid interlocks

EX-AZM 170-...-3G/D

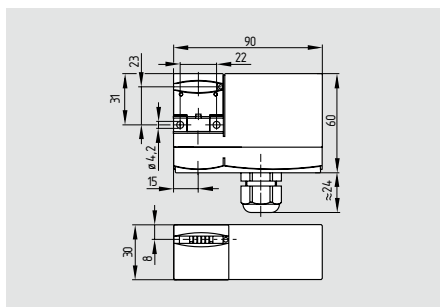

- Ex certified
- Interlock with protection against incorrect locking
- Thermoplastic enclosure
- **cut clamp terminals**
- Compact design
- Manual release
- Long life
- Double insulated \square
- High holding force 1000 N
- Latching force 5 N or 30 N
- Power to unlock / Power to lock
- Individual coding available on request
- 1 cable entry M20
- Including Ex-certified screwed cable gland

Technical data

Equipment category: Ex II 3GD
 Ex protection: Ex nC IIC T5 X
 $\text{Ex tD A22 IP67 T80°C X}$

Standards: EN 60947-5-1
 EN 61241-0
 EN 61241-1
 EN 60079-0
 EN 60079-15
 BG-GS-ET-19

Enclosure: glass-fibre reinforced thermoplastic, self-extinguishing

Max. impact energy: 1 J
 Actuating speed: max. 1 m/s
 Actuator and locking bolt: stainless steel 1.4301
 Protection class: IP67 to EN 60529
 Contact material: Silver
 Contact type: change-over contact with double break, type Zb or 2 NC contacts, with galvanically separated contact bridges

Switching system: $\ominus \text{EN 60947-5-1}$, slow action, positive break NC contact

Connection: cut clamp terminals
 Cable section: 0.75 – 1.0 mm², flexible
 U_{imp} : 4 kV
 U_i : 250 V
 I_{the} : 2 A
 Utilisation category: AC-15, DC-13
 I_e/U_e : 2 A / 230 VAC
 2 A / 24 VDC

Max. fuse rating: 2 A gG D-fuse
 Positive break travel: 11 mm
 Positive break force: 6 N for each NC contact fitted

Magnet: 100% ED
 U_s : 24 VAC/DC
 Power consumption: max. 10 W
 Ambient temperature: -15 °C ... +45 °C
 Mechanical life: > 1 million operations
 F_{max} : 1000 N
 Latching force: 30 N for ordering suffix R
 Cable cross-section of the cable glands: min. \varnothing 6.5 mm
 max. \varnothing 12 mm
 Ex II 2D

Contact variants

Power to unlock 1 NO / 1 NC

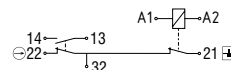

2 NC contacts

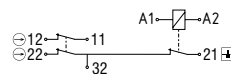

Power to lock 1 NO / 1 NC

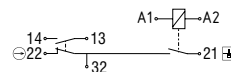

2 NC contacts

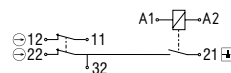

Approvals



Ordering details

EX-AZM 170-①Z②K③-24VAC/DC-④-3G/D

No.	Option	Description
①	11 02	1NO/1NC contacts 2 NC contact
②	R	Latching force 5 N Latching force 30 N
③	A	Power to unlock Power to lock
④	1637	Manual release Gold-plated contacts

Note

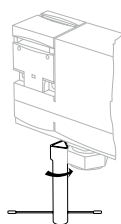

Manual release (left)

- For manual release using M5 triangular key, available as accessory
- Included in standard version

Note

The contact 21-32 is actuated when A1-A2 is energised or de-energised. At least one magnetic contact with positive break \ominus must be integrated in the safety circuit. Circuit diagrams show the de-energised condition with actuator inserted (0 in switch travel diagram).

Interlocks with the power to lock principle may only be used in special cases after a thorough evaluation of the accident risk, since the guarding device can immediately be opened on failure of the electrical power supply or when the main switch is opened.

Actuators must be ordered separately.

Solenoid interlocks

System components

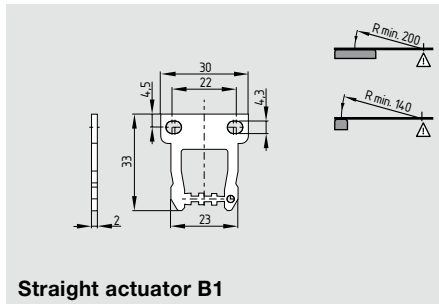

System components

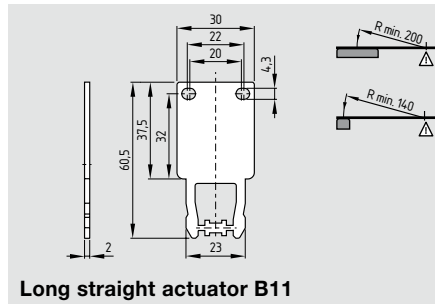

System components

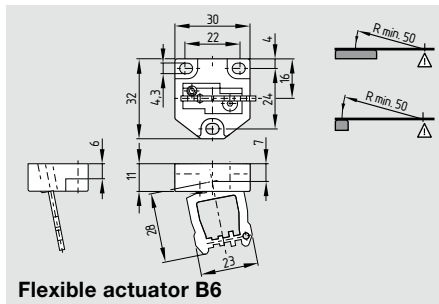
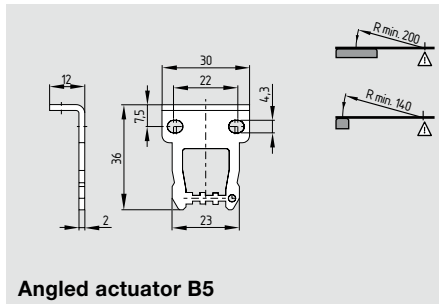
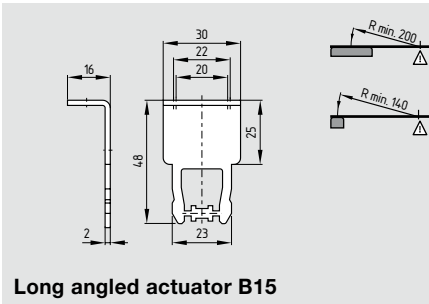
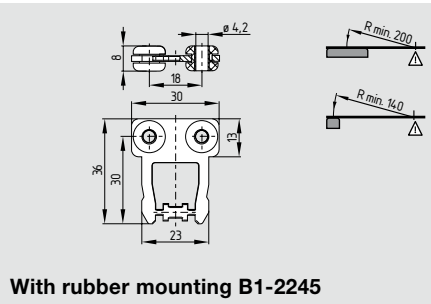
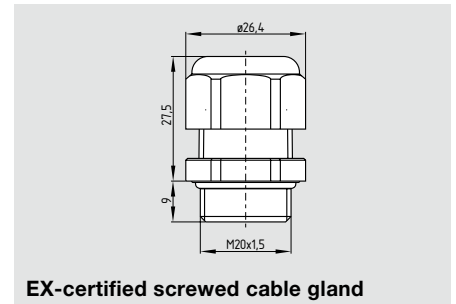

Ordering details

Straight actuator **AZ 17/170-B1**
 with rubber mountings **AZ 17/170-B1-2245**
 Angled actuator **AZ 17/170-B5**
 Flexible actuator **AZM 170-B6**

Ordering details

Long straight actuator **AZ 17/170-B11**
 Long angled actuator **AZ 17/170-B15**

Ordering details

EX-certified
 screwed cable gland **EX-KLE-M20x1.5**

Gas zone 2 / Dust zone 22

Solenoid interlocks

EX-AZM 161-...-3D

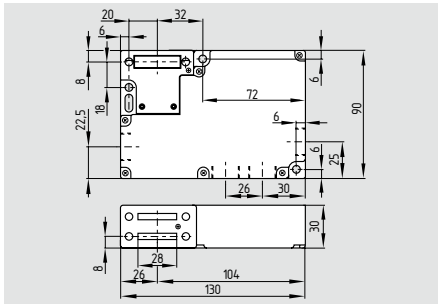

- Ex certified
- Interlock with protection against incorrect locking
- Thermoplastic enclosure
- 6 contacts
- Manual release
- Long life
- Double insulated \square
- High holding force 2000 N
- Large wiring compartment
- Power to unlock / Power to lock
- Cage clamps or screw terminals
- 4 cable entries M16
- Including Ex-certified screwed cable gland

Dust zone 22

Technical data

Equipment category: II 3D
 Ex protection: Ex tD A22 IP67 T80°C X
 Standards: EN 60947-5-1
 EN 61241-0
 EN 61241-1
 BG-GS-ET-19

Enclosure: glass-fibre reinforced thermo-plastic, self-extinguishing

Actuator and locking bolt: stainless steel 1.4301

Protective cover: Steel painted

Max. impact energy: 1 J
 7 J (with AZM 161-ME)

Actuating speed: max. 1 m/s

Protection class: IP67

Contact material: Silver

Contact type: change-over contact with double break, type Zb, with galvanically separated contact bridges

Switching system: \ominus EN 60947-5-1, slow action, positive break NC contact

Connection: screw terminals or cage clamps

Cable section: max. 1.5 mm² (incl. conductor ferrules)

Cable entry: 4x M16

U_{imp} : 4 kV

U_i : 250 V

I_{the} : 5 A

Utilisation category: AC-15, DC-13

I_e/U_e : 4 A / 230 VAC
 2.5 A / 24 VDC

Max. fuse rating: 6 A gG D-fuse

Positive break travel: 9.5 mm

Positive break force: 10 N for each NC contact fitted

U_s : 24 VAC/DC

Magnet: 100% ED

Power consumption: max. 10 W

Ambient temperature: -15 °C ... +50 °C

Mechanical life: > 1 million operations

F_{max} : 2000 N

Latching force: 30 N for ordering suffix R

Cable cross-section of the cable glands: min. \varnothing 5 mm
 max. \varnothing 10 mm
 II 2D

Contact variants

2 NO contact / 4 NC contacts (12/12)

Power to unlock

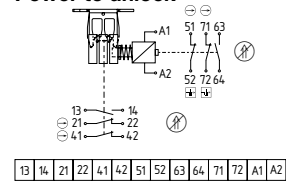

Power to lock

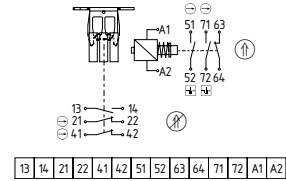

Approvals



Ordering details

EX-AZM 161 ①-12/12-②K③-024-3D

No.	Option	Description
①	SK	Screw terminals
	CC	Cage clamps
②		Latching force 5 N
	R	Latching force 30 N
③		Power to unlock
	A	Power to lock

Note

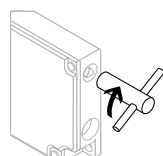

Manual release

- For manual release using M5 triangular key, available as accessory
- For Maintenance purposes only.

Note

At least one magnetic contact with positive break \ominus must be integrated in the safety circuit.

Contact variants are shown in the de-energised condition with the actuator inserted (0 in switch travel diagram).

Interlocks with the power to lock principle may only be used in special cases after a thorough evaluation of the accident risk, since the guarding device can immediately be opened on failure of the electrical power supply or when the main switch is opened.

Actuators and protective cover must be ordered separately.

Solenoid interlocks

System components

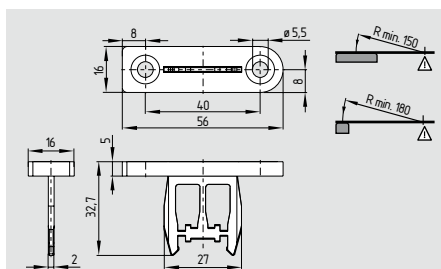

Straight actuator B1

System components

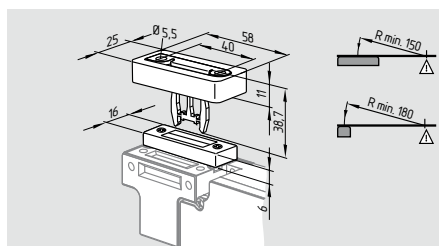

Actuator B1-2024 with slot lip-seal

System components

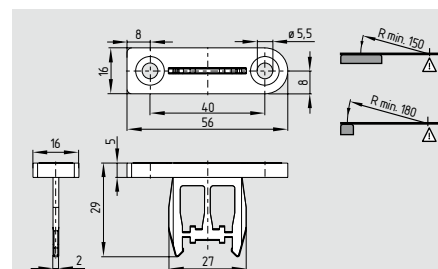

Shortened straight actuator B1S

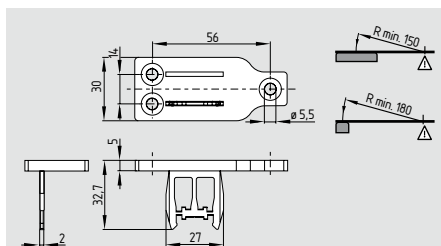

Straight actuator B1E

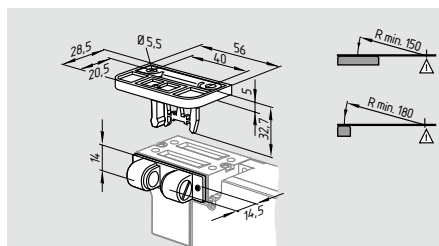

Actuator B1-2053 with ball latch

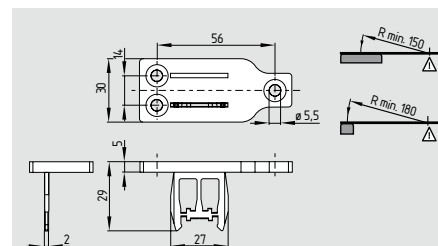

Shortened straight actuator B1ES

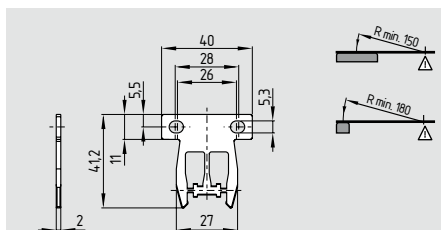

Straight actuator B1F

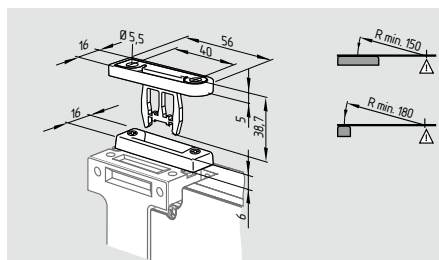

Actuator B1-2177 with centering guide

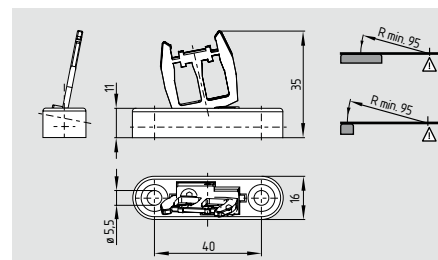

Shortened angled actuator B6S

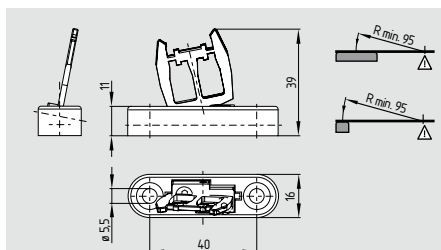

Flexible actuator B6

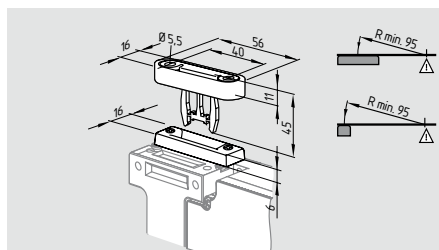

Actuator B6-2177 with centering guide

Ordering details

Straight actuator **AZM 161-B1**
 Straight actuator **AZM 161-B1E**
 Straight actuator **AZM 161-B1F**
 Flexible actuator **AZM 161-B6**

Ordering details

Straight actuator with slot lip-seal **AZM 161-B1-2024**
 Straight actuator with ball latch **AZM 161-B1-2053**
 Straight actuator with centering guide **AZM 161-B1-2177**
 Flexible actuator with centering guide **AZM 161-B6-2177**

Ordering details

Shortened straight actuator **AZM 161-B1S**
 Shortened straight actuator **AZM 161-B1ES**
 Shortened angled actuator **AZM 161-B6S**

Dust zone 22

Solenoid interlocks

System components

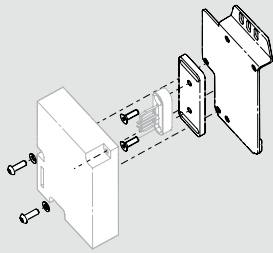

Mounting set MS AZM 161 P

System components

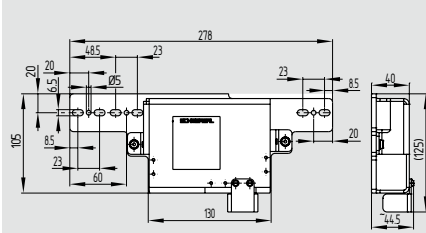

Protective cover AZM 161-ME

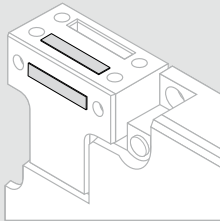

Slot sealing plug AZM 161

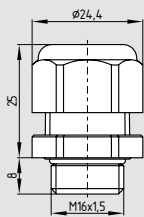

EX-certified screwed cable gland

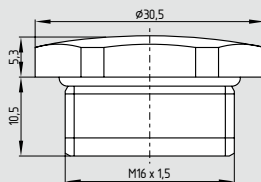

EX-certified screw plug

Ordering details

Mounting set	MS AZM 161 P
	MS AZM 161 R/P
Slot sealing plug AZM 161	101145379
Tamperproof screws with unidirectional slots (without drawing)	
M5 x 12	101135338
M5 x 16	101135339
M5 x 20	101135340
(Quantity 2 pcs)	
EX-certified screwed cable gland	EX-KLE-M16x1.5
EX-certified screw plug	EX-VS-M16x1.5

Ordering details

Protective cover	AZM 161-ME
------------------	-------------------

Download now



Data sheets, mounting and wiring instructions, declaration of conformity and other information at: www.schmersal.com

More Details



Detailed technical information at:
www.schmersal.com

Position switches with safety function



The position switches with safety function are suitable for sliding and hinged guards, which need to be closed in order to ensure the required operational safety.

Content	
EX-Z/T 235-...-3D	44
EX-Z/T 335-...-3G/D	54
EX-Z/T 355-...-3G/D	55
EX-MAF 330-...-3D	60
EX-T 335-...	62
EX-T/M 441-...	68
EX-T/M 250-...	69
EX-TS 064-...	70
EX-MS 064-...	71
EX-T. 064-...	73
EX-M. 064 R	74
EX-M. 064 L	75

Position switches with safety function

Plunger S

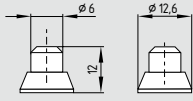

- Actuator type B to EN 50047
- Actuating force: Min. 9 N
- Positive break force: 19 N
- Actuating speed with actuating angle 0° to switch axis
 Snap action: Min. 10 mm/min, max. 1 m/s
 Slow action: Min. 60 mm/min, max. 1 m/s

Contact variants

Contacts/ Switch travel	Snap action	Slow action	Slow action with overlapping contacts	Slow action with staggered contacts
1 NO / 1 NC	EX-ZS 235-11Z-3D 	EX-TS 235-11Z-3D 	EX-TS 235-11ZUE-3D 	
2 NC	EX-ZS 235-02Z-3D 	EX-TS 235-02Z-3D 		EX-TS 235-02ZH-3D
2 NO		EX-TS 235-20Z-3D 		EX-TS 235-20ZH-3D

Roller plunger R

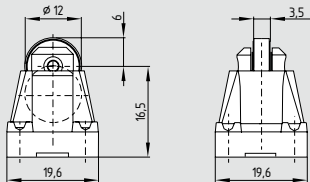

- Actuator type C to EN 50047
- Actuating force: Min. 9 N
- Positive break force: 19 N
- Actuating speed with actuating angle 30° to switch axis
 Snap action: Min. 20 mm/min, max. 1 m/s
 Slow action: Min. 120 mm/min, max. 1 m/s

Contact variants

Contacts/ Switch travel	Snap action	Slow action	Slow action with overlapping contacts	Slow action with staggered contacts
1 NO / 1 NC	EX-ZR 235-11Z-3D 	EX-TR 235-11Z-3D 	EX-TR 235-11ZUE-3D 	
2 NC	EX-ZR 235-02Z-3D 	EX-TR 235-02Z-3D 		EX-TR 235-02ZH-3D
2 NO		EX-TR 235-20Z-3D 		EX-TR 235-20ZH-3D

Position switches with safety function

Plunger 4S

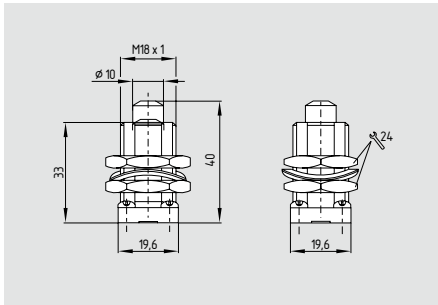

- Actuating force: Min. 9 N
- Positive break force: 19 N
- Actuating speed with actuating angle 0° to switch axis
 Snap action: Min. 10 mm/min, max. 1 m/s
 Slow action: Min. 60 mm/min, max. 1 m/s

Contact variants

Contacts/ Switch travel	Snap action	Slow action	Slow action with overlapping contacts	Slow action with staggered contacts
1 NO / 1 NC	EX-Z4S 235-11Z-3D 	EX-T4S 235-11Z-3D 	EX-T4S 235-11ZUE-3D 	
2 NC	EX-Z4S 235-02Z-3D 	EX-T4S 235-02Z-3D 		EX-T4S 235-02ZH-3D
2 NO		EX-T4S 235-20Z-3D 		EX-T4S 235-20ZH-3D

Dust zone 22

Roller plunger 4R

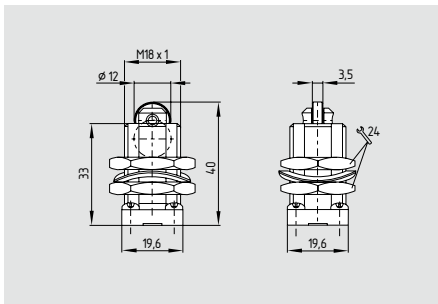

- Actuating force: Min. 9 N
- Positive break force: 19 N
- Actuating speed with actuating angle 30° to switch axis
 Snap action: Min. 20 mm/min, max. 1 m/s
 Slow action: Min. 120 mm/min, max. 1 m/s

Contact variants

Contacts/ Switch travel	Snap action	Slow action	Slow action with overlapping contacts	Slow action with staggered contacts
1 NO / 1 NC	EX-Z4R 235-11Z-3D 	EX-T4R 235-11Z-3D 	EX-T4R 235-11ZUE-3D 	
2 NC	EX-Z4R 235-02Z-3D 	EX-T4R 235-02Z-3D 		EX-T4R 235-02ZH-3D
2 NO		EX-T4R 235-20Z-3D 		EX-T4R 235-20ZH-3D

Position switches with safety function

Offset roller lever 1R

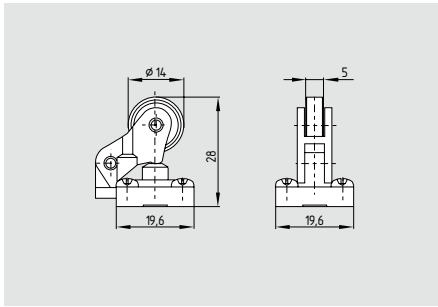

- Actuating force: Min. 9 N
- Positive break force: 19 N
- Actuating speed with actuating angle 30° to switch axis
 Snap action: Min. 27 mm/min, max. 1 m/s
 Slow action: Min. 160 mm/min, max. 1 m/s

Contact variants

Contacts/ Switch travel	Snap action	Slow action	Slow action with overlapping contacts
1 NO / 1 NC	EX-Z1R 235-11Z-3D 	EX-T1R 235-11Z-3D 	EX-T1R 235-11ZUE-3D
2 NC	EX-Z1R 235-02z-3D 	EX-T1R 235-02Z-3D 	
2 NO		EX-T1R 235-20Z-3D 	

Offset roller lever K

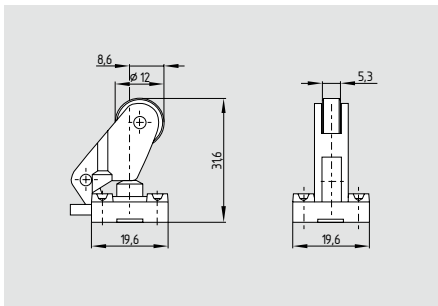

- Actuator type E to EN 50047
- Actuating force: Min. 9 N
- Positive break force: 19 N
- Actuating speed with actuating angle 30° to switch axis
 Snap action: Min. 24 mm/min, max. 1 m/s
 Slow action: Min. 240 mm/min, max. 1 m/s

Contact variants

Contacts/ Switch travel	Snap action	Slow action	Slow action with overlapping contacts	Slow action with staggered contacts
1 NO / 1 NC	EX-ZK 235-11Z-3D 	EX-TK 235-11Z-3D 	EX-TK 235-11ZUE-3D 	
2 NC	EX-ZK 235-02Z-3D 	EX-TK 235-02Z-3D 		EX-TK 235-02ZH-3D
2 NO		EX-TK 235-20Z-3D 		EX-TK 235-20ZH-3D

Position switches with safety function

Angle roller lever 3K

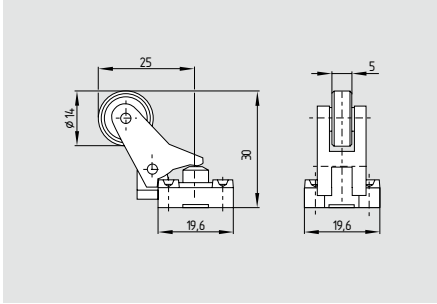

- Actuating force: Min. 9 N
- Positive break force: 19 N
- Actuating speed with actuating angle 30° to switch axis
Snap action: Min. 27 mm/min, max. 1 m/s
Slow action: Min. 160 mm/min, max. 1 m/s
- Actuation from bottom parallel to the switch, therefore only suitable for small housings (Z/T 235 and Z/T 236)

Contact variants

Contacts/ Switch travel	Snap action	Slow action	Slow action with overlapping contacts	Slow action with staggered contacts
1 NO / 1 NC	EX-Z3K 235-11Z-3D 	EX-T3K 235-11Z-3D 	EX-T3K 235-11ZUE-3D 	
2 NC	EX-Z3K 235-02Z-3D 	EX-T3K 235-02Z-3D 		EX-T3K 235-02ZH-3D
2 NO		EX-T3K 235-20Z-3D 		EX-T3K 235-20ZH-3D

Dust zone 22

Angle roller lever 4K

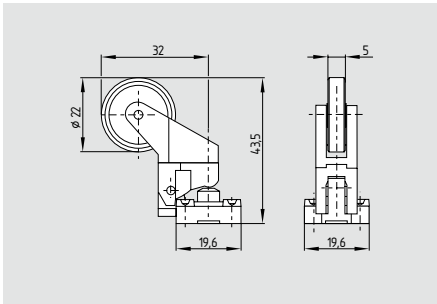

- Actuating force: Min. 6 N
- Positive break force: 16 N
- Actuating speed with actuating angle 30° to switch axis
Snap action: Min. 44 mm/min, max. 1 m/s
Slow action: Min. 264 mm/min, max. 1 m/s
- Actuation from bottom parallel to the switch, therefore only suitable for small housings (Z/T 235 and Z/T 236)

Contact variants

Contacts/ Switch travel	Snap action	Slow action	Slow action with overlapping contacts	Slow action with staggered contacts
1 NO / 1 NC	EX-Z4K 235-11Z-3D 	EX-T4K 235-11Z-3D 	EX-T4K 235-11ZUE-3D 	
2 NC	EX-Z4K 235-02Z-3D 	EX-T4K 235-02Z-3D 		EX-T4K 235-02ZH-3D
2 NO		EX-T4K 235-20Z-3D 		EX-T4K 235-20ZH-3D

Position switches with safety function

Angle roller lever K4

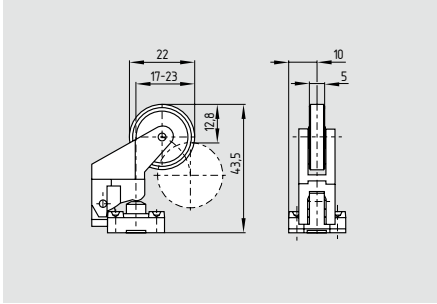

- Actuating force: Min. 6 N
- Positive break force: 16 N
- Actuating speed with actuating angle 30° to switch axis
 Snap action: Min. 56 mm/min, max. 1 m/s
 Slow action: Min. 336 mm/min, max. 1 m/s

Contact variants

Contacts/ Switch travel	Snap action	Slow action	Slow action with overlapping contacts	Slow action with staggered contacts
1 NO / 1 NC	EX-ZK4 235-11Z-3D 	EX-TK4 235-11Z-3D 	EX-TK4 235-11ZUE-3D 	
2 NC	EX-ZK4 235-02Z-3D 	EX-TK4 235-02Z-3D 		EX-TK4 235-02ZH-3D
2 NO		EX-TK4 235-20Z-3D 		EX-TK4 235-20ZH-3D

Roller lever 1H

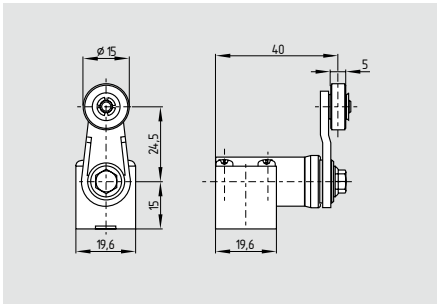

- Plastic lever
- Actuator type A to EN 50047
- Angle of roller lever adjustable in 10° steps
- Actuating torque: Min. 15 Ncm
- Positive break torque: 18.5 Ncm
- Actuating speed with actuating angle 30° to switch axis
 Snap action: Min. 92 mm/min, max. 1 m/s
 Slow action: Min. 492 mm/min, max. 1 m/s
- Actuator head gasket, ordering suffix -Z

Contact variants

Contacts/ Switch travel	Snap action	Slow action	Slow action with overlapping contacts	Slow action with staggered contacts
1 NO / 1 NC	EX-ZV1H 235-11Z-3D 	EX-TV1H 235-11Z-3D 	EX-TV1H 235-11ZUE-3D 	
2 NC	EX-ZV1H 235-02Z-3D 	EX-TV1H 235-02Z-3D 		EX-TV1H 235-02ZH-3D
2 NO		EX-TV1H 235-20Z-3D 		EX-TV1H 235-20ZH-3D

Position switches with safety function

Roller lever 7H

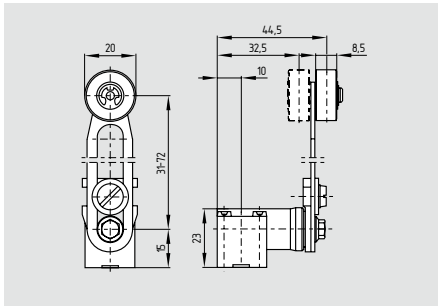

- only for positioning tasks
- Angle of roller lever adjustable in 10° steps
- Actuating torque: Min. 15 Ncm
- Actuating speed with actuating angle 30° to switch axis
 Snap action: Min. 240 mm/min, max. 1 m/s
 Slow action: Min. 1440 mm/min, max. 1 m/s
- Actuator head gasket, ordering suffix -Z

Contact variants

Contacts/ Switch travel	Snap action	Slow action	Slow action with overlapping contacts	Slow action with staggered contacts
1 NO / 1 NC	EX-ZV7H 235-11Z-3D 	EX-TV7H 235-11Z-3D 	EX-TV7H 235-11ZUE-3D 	
2 NC	EX-ZV7H 235-02Z-3D 	EX-TV7H 235-02Z-3D 		EX-TV7H 235-02ZH-3D
2 NO		EX-TV7H 235-20Z-3D 		EX-TV7H 235-20ZH-3D

Dust zone 22

7H-2138

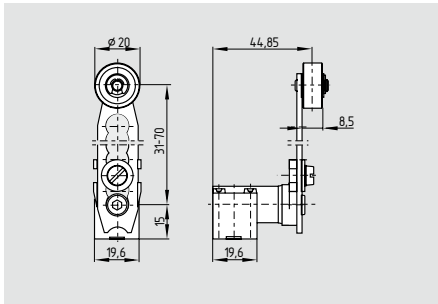

- Angle of roller lever adjustable in 10° steps
- Actuating torque: Min. 15 Ncm
- Positive break torque: 18.5 Ncm
- Actuating speed with actuating angle 30° to switch axis
 Snap action: Min. 240 mm/min, max. 1 m/s
 Slow action: Min. 1440 mm/min, max. 1 m/s
- Actuator head gasket, ordering suffix -Z

Contact variants

Contacts/ Switch travel	Snap action	Slow action	Slow action with overlapping contacts	Slow action with staggered contacts
1 NO / 1 NC	EX-ZV7H 235-11Z-2138-3D 	EX-TV7H 235-11Z-2138-3D 	EX-TV7H 235-11ZUE-2138-3D 	
2 NC	EX-ZV7H 235-02Z-2138-3D 	EX-TV7H 235-02Z-2138-3D 		EX-TV7H 235-02ZH-2138-3D
2 NO		EX-TV7H 235-20Z-2138-3D 		EX-TV7H 235-20ZH-2138-3D

Position switches with safety function

Rod lever 10H

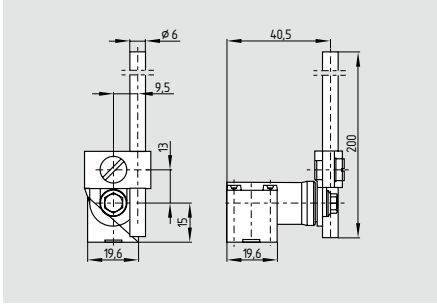

- only for positioning tasks
- Angle of roller lever adjustable in 10° steps
- Plastic rod
- Actuating torque: Min. 15 Ncm
- Actuating speed with actuating angle 30° to switch axis
Snap action: Min. 687 mm/min, max. 1 m/s
Slow action: Min. 4122 mm/min, max. 1 m/s
- Actuator head gasket, ordering suffix -Z
- Aluminium rod, ordering suffix -1183

Contact variants

Contacts/ Switch travel	Snap action	Slow action	Slow action with overlapping contacts	Slow action with staggered contacts
1 NO / 1 NC	EX-ZV10H 235-11Z-3D 	EX-TV10H 235-11Z-3D 	EX-TV10H 235-11ZUE-3D 	
2 NC	EX-ZV10H 235-02Z-3D 	EX-TV10H 235-02Z-3D 		EX-TV10H 235-02ZH-3D
2 NO		EX-TV10H 235-20Z-3D 		EX-TV10H 235-20ZH-3D

Roller lever 12H

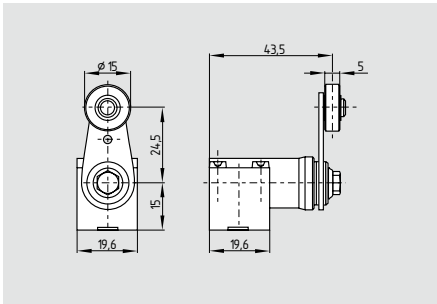

- Metal lever with plastic roller
- Actuator type A to EN 50047
- Angle of roller lever adjustable in 10° steps
- Actuating torque: Min. 15 Ncm
- Positive break torque: 18.5 Ncm
- Actuating speed with actuating angle 30° to switch axis
Snap action: Min. 687 mm/min, max. 1 m/s
Slow action: Min. 4122 mm/min, max. 1 m/s
- Actuator head gasket, ordering suffix -Z
- Available with metal roller, ordering suffix -RMS

Contact variants

Contacts/ Switch travel	Snap action	Slow action	Slow action with overlapping contacts	Slow action with staggered contacts
1 NO / 1 NC	EX-ZV12H 235-11Z-3D 	EX-TV12H 235-11Z-3D 	EX-TV12H 235-11ZUE-3D 	
2 NC	EX-ZV12H 235-02Z-3D 	EX-TV12H 235-02Z-3D 		EX-TV12H 235-02ZH-3D
2 NO		EX-TV12H 235-20Z-3D 		EX-TV12H 235-20ZH-3D

Position switches with safety function

Roller lever 14H

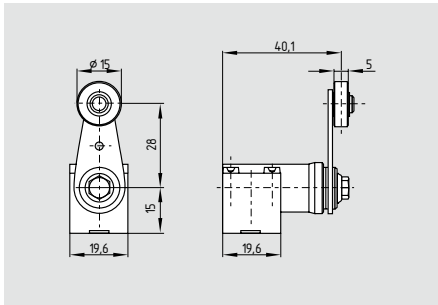

- Metal lever with plastic roller
- Angle of roller lever adjustable in 10° steps
- Actuating torque: Min. 15 Ncm
- Positive break torque: 18.5 Ncm
- Actuating speed with actuating angle 30° to switch axis
 Snap action: Min. 687 mm/min, max. 1 m/s
 Slow action: Min. 4122 mm/min, max. 1 m/s
- Actuator head gasket, ordering suffix -Z
- Available with metal roller, ordering suffix -RMS

Contact variants

Contacts/ Switch travel	Snap action	Slow action	Slow action with overlapping contacts	Slow action with staggered contacts
1 NO / 1 NC	EX-ZV14H 235-11Z-3D 	EX-TV14H 235-11Z-3D 	EX-TV14H 235-11ZUE-3D 	
2 NC	EX-ZV14H 235-02Z-3D 	EX-TV14H 235-02Z-3D 		EX-TV14H 235-02ZH-3D
2 NO		EX-TV14H 235-20Z-3D 		EX-TV14H 235-20ZH-3D

More Details

Produkt-Hierarchie

- Sicheres Schalten und Erfassen
 - Sicherheitsschalter mit getrenntem Betätiger
 - Sicherheitszuhaltung
 - Positionsschalter
 - Sicherheitsschalter für drehbare Schutzrichtungen
 - Sicherheits-Sensoren
 - Selbst-Notsschalter
 - NOT-HALT-Taster
 - Sicherheitsgerichteter Laserscanner
 - Sicherheits-Lichtschranken
 - SLB 200
 - SLB 400
 - SLB 400-E50-21P Sender**
 - SLB 400-R50-21P Empfänger
 - Zubehör
 - Sicherheitsbausteine zur Überwachung von Sicherheits-Lichtschranken
 - Sicherheits-Lichtvorhänge, Sicherheits-Lichtgitter
 - Zweihandbedienpulte
 - Türgriffschalter
 - Zustimmungsschalter
 - Sicherheitsgerichteter taktiler Sensor
 - Fußschalter
 - AS-Interface Safety at Work

Home > Sicherheits-Lichtschranken > SLB 400 > SLB 400-E50-21P Sender

SLB 400-E50-21P Sender

Datenblatt

- Reichweite 15 m
- Einbautecker drehbar

Daten | Dokumente | CAD | Abbildungen

Bestelldaten

Produkt-Typbezeichnung	SLB 400-E50-21P Sender
Artikelnummer	1138898
EAN Code	4030661281544

Zulassung

Zulassung	BG
-----------	----

Allgemeine Daten

Produkt-Name	SLB 400
Vorschriften	CE/EN 61496
Richtlinienkonformität (J/N)	Ja
Betriebsmittel-Schutzklasse	keine
Sicherheitsstyp gemäß IEC 61496-1	
Werkstoffe	
- Werkstoff des Gehäuses	Kunststoff
Gewicht	42 g
Reichweite des Schutzfeldes	15000 mm
min. Objektgröße	Ø 13 mm
Reaktionszeit	25 ms (Nur in Verbindung mit einem Sicherheitsbaustein)
Wellenlänge des Sensors	800 nm
Abstrahlwinkel	± 2°

Fertig

Detailed technical information at:
www.schmersal.net

Position switches with safety function

EX-Z/T 335-...-3G/D

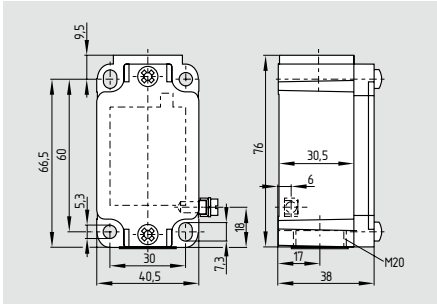

- Ex certified
- Mounting details to EN 50041
- Metal enclosure
- Snap action with constant contact pressure up to switching point
- Slow or snap action available with 2 positive break NC contacts to EN 60947-5-1
- Slow action available with overlapping or staggered contacts
- Wide range of alternative actuators
- Actuator heads can be repositioned by 4 x 90°
- Angle of roller lever adjustable in 10° steps
- Good resistance to oil and petroleum spirit
- 1 cable entry M20
- incl. Ex-certified cable gland

Technical data

Equipment category: II 3GD
 Ex protection: Ex nC IIC T5 X
 Ex tD A22 IP67 T90°C X

Standards: EN 60947-5-1
 EN 61241-0
 EN 61241-1
 EN 60079-0
 EN 60079-15
 BG-GS-ET-15

Design: DIN EN 50041
 Enclosure: light-alloy diecast, paint finish

Max. impact energy: 4 J
 Actuating speed: max. 1 m/s
 Protection class: IP67 to EN 60529
 Contact material: Silver
 Contact type: Change-over contact with double break, type Zb or 2 NC contacts, with galvanically separated contact bridges

Switching system: \ominus EN 60947-5-1, slow action or snap action, positive break NC contact

Connection: screw terminals
 Cable section: max. 2.5 mm² (including conductor ferrules)

Cable entry: M20
 U_{imp}: 6 kV
 -03Z, -12Z: 4kV
 U_i: 500 V
 -03Z, -12Z: 250 V
 I_{the}: 10 A
 Utilisation category: AC-15, DC-13
 I_e/U_e: 4 A / 230 VAC
 4 A / 24VDC

Max. fuse rating: 6 A gG D-fuse
 Ambient temperature: -20 °C ... +60 °C
 Mechanical life: 30 million operations
 Switching frequency: max. 5000/h
 Bounce duration: Snap action: in accordance with actuating speed;
 Slow action: < 2ms
 Switchover time: Snap action: < 2 ms;
 Slow action: in accordance with actuating speed

Cable cross-section of the cable glands: min. Ø 7 mm
 max. Ø 12 mm
 II 2D

System components

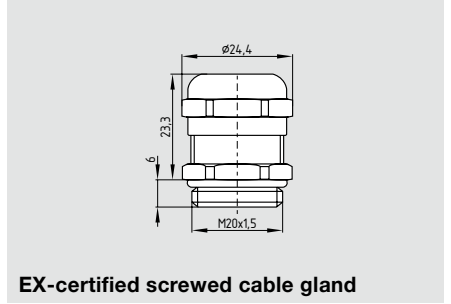

EX-certified screwed cable gland

Approvals



Ordering details

EX-①② 335-③Z④-⑤-⑥-⑦-3G/D

No.	Option	Description
①	Z	Snap action \ominus
	T	Slow action \ominus
②	For the appropriate actuator: see page 58	
③	11	1 NO contact / 1 NC contact
	02	2 NC contacts
	20	2 NO contacts*
	01/01	1 NC contact to the left/ 1 NC contact to the right
	12	1 NO contact / 2 NC contacts
	03	3 NC contacts
④	H	Slow action with staggered contacts
	UE	with overlapping contacts

No.	Option	Description
⑤	1297	Enclosure with transverse slotted holes
⑥	2138	Roller lever 7H for safety duties
⑦	1637	Gold-plated contacts

* Switches with 2 NO contacts are only suitable for positioning tasks!

Ordering details

EX-certified screwed cable gland **EX-KLE-M20x1.5**

Position switches with safety function

EX-Z/T 355-...-3G/D

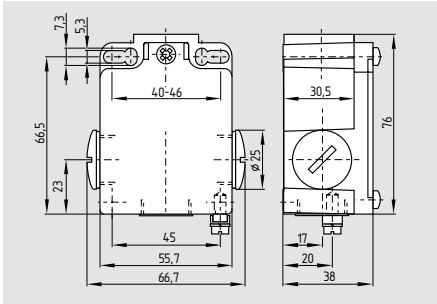

- Ex certified
- Mounting details to EN 50041
- Metal enclosure
- Snap action with constant contact pressure up to switching point
- Slow or snap action available with 2 positive break NC contacts to EN 60947-5-1
- Slow action available with overlapping or staggered contacts
- Wide range of alternative actuators
- Actuator heads can be repositioned by 4 x 90°
- Angle of roller lever adjustable in 10° steps
- Good resistance to oil and petroleum spirit
- 3 cable entries M20
- Including EX-certified screwed cable gland

Approvals



Ordering details

EX-①② 355-③Z④-⑤-⑥-⑦-3G/D

No.	Option	Description
①	Z	Snap action ⊖
	T	Slow action ⊖
②	For the appropriate actuator: see page 58	
③	11	1 NO contact / 1 NC contact
	02	2 NC contacts
	20	2 NO contacts*
	01/01	1 NC contact to the left/ 1 NC contact to the right
	12	1 NO contact / 2 NC contacts
	03	3 NC contacts
④	H	Slow action
	UE	with staggered contacts with overlapping contacts

Technical data

Equipment category: II 3GD
 Ex protection: Ex nC IIC T5 X
 Ex tD A22 IP67 T90°C X

Standards: EN 60947-5-1
 EN 61241-0
 EN 61241-1
 EN 60079-0
 EN 60079-15
 BG-GS-ET-15
 DIN EN 50041

Design: light-alloy diecast, paint finish

Enclosure: light-alloy diecast, paint finish

Max. impact energy: 1 J
 Actuating speed: max. 1 m/s
 Protection class: IP67 to EN 60529
 Contact material: Silver
 Contact type: Change-over contact with double break, type Zb or 2 NC contacts, with galvanically separated contact bridges

Switching system: \ominus EN 60947-5-1, slow action or snap action, positive break NC contact

Connection: screw terminals
 Cable section: max. 2.5 mm² (including conductor ferrules)

Cable entry: 3 x M 20
 U_{imp}: 6 kV
 -03z, -12z: 4kV
 U_i: 500 V
 -03z, -12z: 250 V
 I_{the}: 10 A
 Utilisation category: AC-15, DC-13
 I_e/U_e: 4 A / 230 VAC
 4 A / 24VDC

Max. fuse rating: 6 A gG D-fuse
 Ambient temperature: -20 °C ... +60 °C
 Mechanical life: 30 million operations
 Switching frequency: max. 5000/h
 Bounce duration: Snap action: in accordance with actuating speed;
 Slow action: < 2ms
 Switchover time: Snap action: < 2 ms;
 Slow action: in accordance with actuating speed

Cable cross-section of the cable glands: min. Ø 7 mm
 max. Ø 12 mm
 II 2D

System components

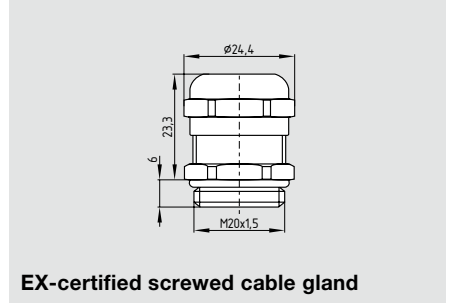

EX-certified screwed cable gland

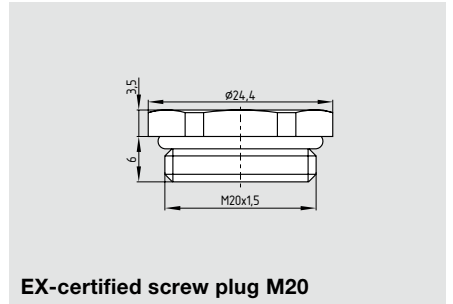

EX-certified screw plug M20

Ordering details

EX-certified screwed cable gland **EX-KLE-M20x1.5**
 EX-certified screw plug **EX-VS-M20x1.5**

No.	Option	Description
⑤	1297	Enclosure with transversely slotted mounting holes
⑥	2138	Roller lever 7H for safety duties
⑦	1637	Gold-plated contacts

* Switches with 2 NO contacts are only suitable for positioning tasks!

Position switches with safety function

Plunger S

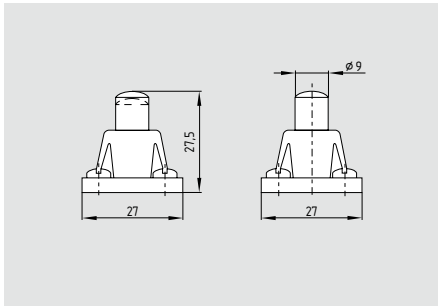

- Actuator type B to EN 50041
- Required actuating force
Snap action: 12 N
Slow action: 17 N
- Actuating speed with actuating angle 0° to switch axis: max. 0.5 m/s

Contact variants

Contacts/ Switch travel	Snap action	Slow action	Slow action with overlapping contacts	Slow action with staggered contacts
1 NO / 1 NC	EX-ZS 3..-11Z-3G/D 	EX-TS 3..-11Z-3G/D 	EX-TS 3..-11ZUE-3G/D 	
2 NC	EX-ZS 3..-02Z-3G/D 	EX-TS 3..-02Z-3G/D 		EX-TS 3..-02ZH-3G/D
2 NO		EX-TS 3..-20Z-3G/D 		EX-TS 3..-20ZH-3G/D
1 NO / 2 NC		EX-TS 3..-12Z-3G/D 	EX-TS 3..-12ZUE-3G/D 	
3 NC		EX-TS 3..-03Z-3G/D 		EX-TS 3..-03ZH-3G/D

Roller plunger R

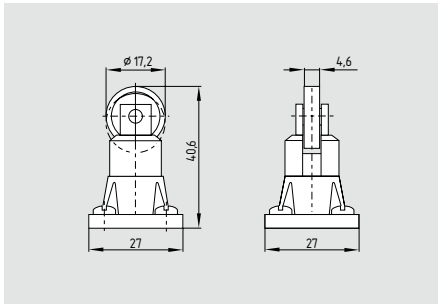

- Actuator type C to EN 50041
- Required actuating force
Snap action: 12 N
Slow action: 17 N
- Actuating speed with actuating angle 30° to switch axis: max. 0.5 m/s

Contact variants

Contacts/ Switch travel	Snap action	Slow action	Slow action with overlapping contacts	Slow action with staggered contacts
1 NO / 1 NC	EX-ZR 3..-11Z-3G/D 	EX-TR 3..-11Z-3G/D 	EX-TR 3..-11ZUE-3G/D 	
2 NC	EX-ZR 3..-02Z-3G/D 	EX-TR 3..-02Z-3G/D 		EX-TR 3..-02ZH-3G/D
2 NO		EX-TR 3..-20Z-3G/D 		EX-TR 3..-20ZH-3G/D
1 NO / 2 NC		EX-TR 3..-12Z-3G/D 	EX-TR 3..-12ZUE-3G/D 	
3 NC		EX-TR 3..-03Z-3G/D 		EX-TR 3..-03ZH-3G/D

Position switches with safety function

Roller lever H

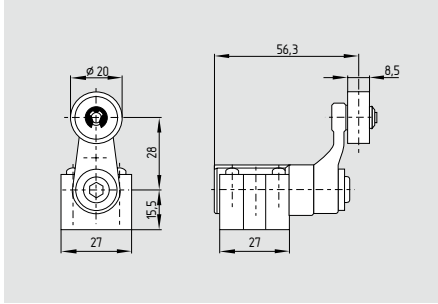

- Actuator type A to EN 50041
- Required actuating torque
Snap action: 26 Ncm
Slow action: 31 Ncm
- Actuating speed with actuating angle 30° to switch axis: max. 2.5 m/s
- also available with plastic roller, ordering suffix: 1H
- Available with metal roller, ordering suffix -RMS

On version EX-TVH ...-01/01Z positive break only to one side.

Contact variants

Contacts/ Switch travel	Snap action	Slow action	Slow action with overlapping contacts	Slow action with staggered contacts
1 NO / 1 NC	EX-Z4VH 3..-11Z-3G/D 	EX-T4VH 3..-11Z-3G/D 	EX-T4VH 3..-11Z-3G/D 	
2 NC	EX-Z4VH 3..-02Z-3G/D 	EX-T4VH 3..-02Z-3G/D 		EX-T4VH 3..-02ZH-3G/D
2 NO		EX-T4VH 3..-20Z-3G/D 		EX-T4VH 3..-20ZH-3G/D
1 NC left 1 NC right		EX-T4VH 3..-01701Z-3G/D 		
1 NO / 2 NC		EX-T4VH 3..-12Z-3G/D 	EX-T4VH 3..-12ZUE-3G/D 	
3 NC		EX-T4VH 3..-03Z-3G/D 		EX-T4VH 3..-03ZH-3G/D

Rod lever 10H

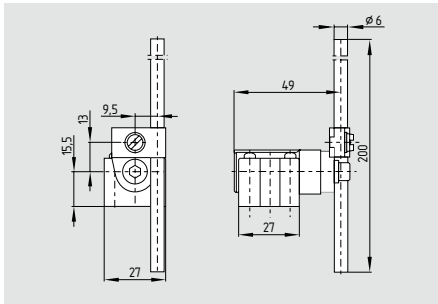

- **only for positioning tasks**
- Actuator type D to EN 50041
- Plastic rod
- Required actuating torque
Snap action: 26 Ncm
Slow action: 31 Ncm
- Actuating speed with actuating angle 30° to switch axis: max. 2.5 m/s
- Aluminium rod, ordering suffix -1183

Contact variants

Contacts/ Switch travel	Snap action	Slow action	Slow action with overlapping contacts	Slow action with staggered contacts
1 NO / 1 NC	EX-Z4V10H 3..-11Z-3G/D 	EX-T4V10H 3..-11Z-3G/D 	EX-T4V10H 3..-11ZUE-3G/D 	
2 NC	EX-Z4V10H 3..-02Z-3G/D 	EX-T4V10H 3..-02Z-3G/D 		EX-T4V10H 3..-02ZH-3G/D
2 NO		EX-T4V10H 3..-20Z-3G/D 		EX-T4V10H 3..-20ZH-3G/D
1 NC left 1 NC right		EX-TV10H 3..-01/01Z-3G/D 		
1 NO / 2 NC		EX-T4V10H 3..-12Z-3G/D 	EX-T4V10H 3..-12ZUE-3G/D 	
3 NC		EX-T4V10H 3..-03Z-3G/D 		EX-T4V10H 3..-03ZH-3G/D

Position switches with safety function

Roller lever 7H

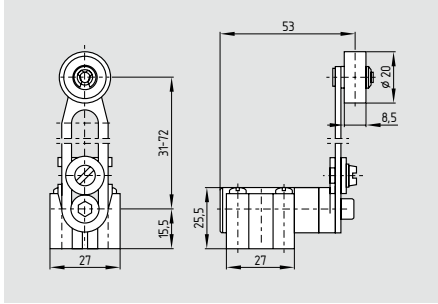

- only for positioning tasks
- Required actuating torque
Snap action: 26 Ncm
Slow action: 31 Ncm
- Actuating speed with actuating angle 30° to switch axis: max. 2.5 m/s

Contact variants

Contacts/ Switch travel	Snap action	Slow action	Slow action with overlapping contacts	Slow action with staggered contacts
1 NO / 1 NC	EX-Z4V7H 3.-11Z-3G/D 	EX-T4V7H 3.-11Z-3G/D 	EX-T4V7H 3.-11ZUE-3G/D 	
2 NC	EX-Z4V7H 3.-02Z-3G/D 	EX-T4V7H 3.-02Z-3G/D 		EX-T4V7H 3.-02ZH-3G/D
2 NO		EX-T4V7H 3.-20Z-3G/D 		EX-T4V7H 3.-20ZH-3G/D
1 NC left 1 NC right		EX-TV7H 3.-01/01Z-3G/D 		
1 NO / 2 NC		EX-T4V7H 3.-12Z-3G/D 	EX-T4V7H 3.-12ZUE-3G/D 	
3 NC		EX-T4V7H 3.-03Z-3G/D 		EX-T4V7H 3.-03ZH-3G/D

7H-2138

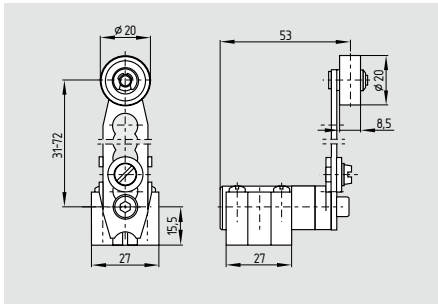

- for safety duties A
- Required actuating torque
Snap action: 26 Ncm
Slow action: 31 Ncm
- Actuating speed with actuating angle 30° to switch axis: max. 2.5 m/s

On version TVH ...-01/01Z positive break only to one side.

Contact variants

Contacts/ Switch travel	Snap action	Slow action	Slow action with overlapping contacts	Slow action with staggered contacts
1 NO / 1 NC	EX-Z4V7H 3.-11Z-2138-3G/D 	EX-T4V7H 3.-11Z-2138-3G/D 	EX-T4V7H 3.-11ZUE-2138-3G/D 	
2 NC	EX-Z4V7H 3.-02Z-2138-3G/D 	EX-T4V7H 3.-02Z-2138-3G/D 		EX-T4V7H 3.-02ZH-2138-3G/D
2 NO		EX-T4V7H 3.-20Z-2138-3G/D 		EX-T4V7H 3.-20ZH-2138-3G/D
1 NC left 1 NC right		EX-TV7H 3.-01/01Z-2138-3G/D 		
1 NO / 2 NC		EX-T4V7H 3.-12Z-2138-3G/D 	EX-T4V7H 3.-12ZUE-2138-3G/D 	
3 NC		EX-T4V7H 3.-03Z-2138-3G/D 		EX-T4V7H 3.-03ZH-2138-3G/D

Position switches with safety function

Offset roller lever 1K

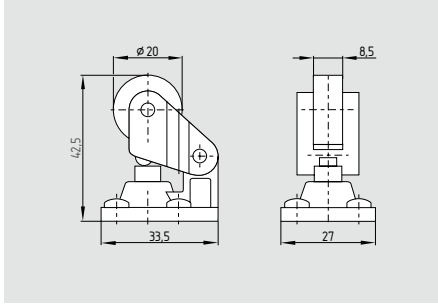

- Required actuating force
Snap action: 12 N
Slow action: 17 N
- Actuating speed with actuating angle 30° to switch axis: max. 0.5 m/s

Contact variants

Contacts/ Switch travel	Snap action	Slow action	Slow action with overlapping contacts	Slow action with staggered contacts
1 NO / 1 NC	EX-Z1K 3..-11Z-3G/D 	EX-T1K 3..-11Z-3G/D 	EX-T1K 3..-11ZUE-3G/D 	
2 NC	EX-Z1K 3..-02Z-3G/D 	EX-T1K 3..-02Z-3G/D 		EX-T1K 3..-02ZH-3G/D
2 NO		EX-T1K 3..-20Z-3G/D 		EX-T1K 3..-20ZH-3G/D
1 NO / 2 NC		EX-T1K 3..-12Z-3G/D 	EX-T1K 3..-12ZUE-3G/D 	
3 NC		EX-T1K 3..-03Z-3G/D 		EX-T1K 3..-03ZH-3G/D

Angle roller lever 3K

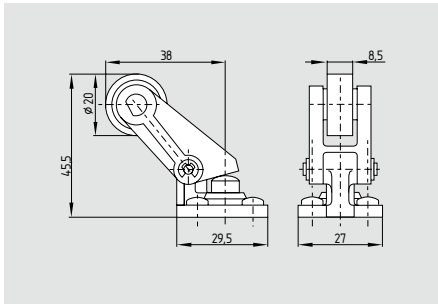

- Required actuating force
Snap action: 12 N
Slow action: 17 N
- Actuating speed with actuating angle 30° to switch axis: max. 0.5 m/s
- Actuation parallel to axis of switch from below

Contact variants

Contacts/ Switch travel	Snap action	Slow action	Slow action with overlapping contacts	Slow action with staggered contacts
1 NO / 1 NC	EX-Z3K 3..-11Z-3G/D 	EX-T3K 3..-11Z-3G/D 	EX-T3K 3..-11ZUE-3G/D 	
2 NC	EX-Z3K 3..-02Z-3G/D 	EX-T3K 3..-02Z-3G/D 		EX-T3K 3..-02ZH-3G/D
2 NO		EX-T3K 3..-20Z-3G/D 		EX-T3K 3..-20ZH-3G/D
1 NO / 2 NC		EX-T3K 3..-12Z-3G/D 	EX-T3K 3..-12ZUE-3G/D 	
3 NC		EX-T3K 3..-03Z-3G/D 		EX-T3K 3..-03ZH-3G/D

Position switches

EX-MAF 330-...-3D

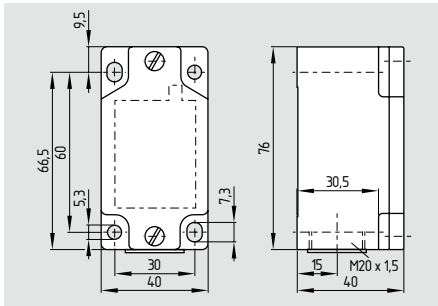

- Ex certified
- Metal enclosure
- Snap action with self-cleaning contacts, change-over contact with double break, silver contacts
- type Zb, with galvanically separated contact bridges
- Suitable for low actuating speeds
- 3 contacts
- Long life
- High level of contact reliability with low voltages and currents
- Mounting details to EN 50041
- Actuator heads can be repositioned in steps 4 x 90°
- Can be mounted on a flat surface
- Slotted holes for adjustment, circular holes for location
- 1 cable entry M20
- Including Ex-certified screwed cable gland
- Actuating speed min. 10 mm/min related to the plunger

Approvals



Ordering details

EX-MAF 330-11Y-①-②

No.	Option	Description
①		without LED
②	AuNi	Gold-nickel alloy contacts

Technical data

Equipment category: II 3D
 Ex protection: Ex tD A22 IP65 T100°C X
 Standards: EN 60947-5-1
 EN 61241-0
 EN 61241-1
 BG-GS-ET-15
 Enclosure: light-alloy diecast, paint finish
 Actuator: stainless steel 1.4301
 Max. impact energy: 4 J
 Actuating speed: max. 1 m/s
 Protection class: IP65 to EN 60529
 Contact material: Silver
 Contact type: Change-over contact with double break type Zb, 3 NC contacts with galvanically separated contact bridges
 Switching system: \ominus EN 60947-5-1, slow action, positive break NC contact
 Connection: screw terminals
 Cable section: max. 2.5 mm²
 min. 0.75 mm²
 (including conductor ferrules)
 Cable entry: M20
 U_{imp} : 4 kV
 U_i : 250 V
 I_{the} : 10 A
 Utilisation category: AC-15, DC-13
 I_e/U_e : 4 A / 230 VAC
 4 A / 24 VDC
 Max. fuse rating: 6 A gG D-fuse
 Positive break travel: 10.7 mm
 Positive break force: each NC contact 5 N
 Ambient temperature: -15 °C ... +80 °C
 Mechanical life: 10 million operations
 Latching force: 30 N for ordering suffix R
 Cable cross-section of the cable glands: min. $\text{Ø } 7 \text{ mm}$
 max. $\text{Ø } 12 \text{ mm}$
 II 2D

System components

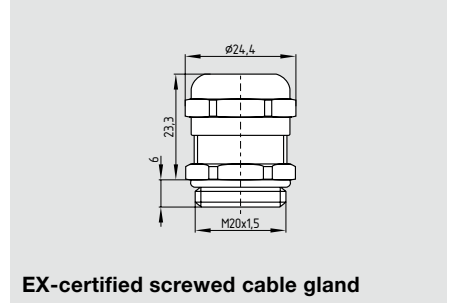

EX-certified screwed cable gland

Dust zone 22

Ordering details

EX-certified
 screwed cable gland **EX-KLE-M20x1.5**

Position switches

Spring rod lever AF

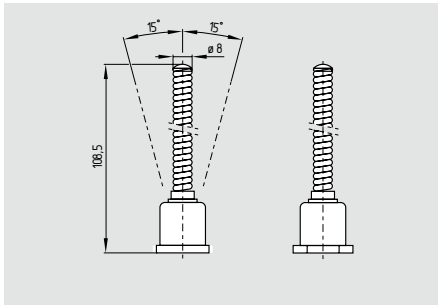

- Required actuating force 9.0 N
- can be deflected in any direction
- Elasticity of the spring allows for deflection above the max. switching angle of 15°

Contact variants

Contacts/
Switch travel

Snap action

1 NO / 1 NC

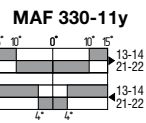

Position switches

EX-T 335-...

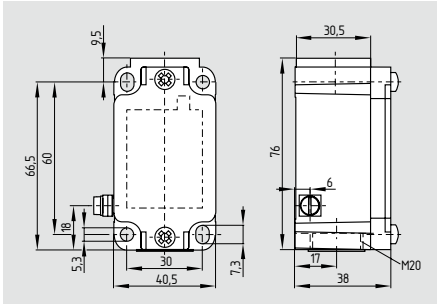

- Ex certified
- Mounting details to EN 50041
- Metal enclosure
- Slow action with 2 positive-break NC contacts to EN 60947-5-1 available
- Slow action available with overlapping contacts
- Wide range of alternative actuators
- Actuator heads can be repositioned by 4 x 90°
- Angle of roller lever adjustable in 10° steps
- Good resistance to oil and petroleum spirit
- 1 cable entry M20
- Including Ex-certified screwed cable gland

Technical data

Equipment category:	⊕ II 2GD
Ex protection:	Ex de IIC T6
	Ex tD A21 IP65 T80°C
Standards:	EN 60947-5-1
	EN 61241-0
	EN 61241-1
	EN 60079-0
	EN 60079-1
	BG-GS-ET-15
Design:	DIN EN 50041
Enclosure:	zinc die-cast, paint finish
Max. impact energy:	7 J
Actuating speed:	max. 1 m/s
Protection class:	IP65, IP67
	to EN 60529
Contact material:	Silver
Contact type:	Change-over contact with double break, type Zb or 2 NC contacts, with galvanically separated contact bridges
Switching system:	⊖ EN 60947-5-1, slow action, positive break NC contact
Connection:	screw terminals
Cable section:	1 mm ² ... 2.5 mm ² (including conductor ferrules)
Cable entry:	M20
U _{imp} :	4 kV
U _i :	250 V
I _{the} :	5 A
Utilisation category:	AC-1
Max. fuse rating:	6 A gG D-fuse
Ambient temperature:	
- cable section 2.5 mm ²	- 20 °C ... + 55 °C
- cable section 1 mm ²	- 20 °C ... + 50 °C
Mechanical life:	> 1 million operations
Switching frequency:	max. 1800/h
Bounce duration:	< 3 ms
Switchover time:	in accordance with actuating speed
Cable cross-section of the cable glands:	min. Ø 7 mm max. Ø 12 mm
	⊕ II 2D

System components

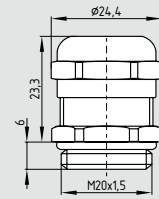

EX-certified screwed cable gland

Approvals



Ordering details

EX-T^① 335-②Y^{③-④}

No.	Option	Description
①		For the appropriate actuator: see page 65
②	11	1 NO contact / 1 NC contact
	02	2 NC contacts
	20	2 NO contacts*
③	UE	with overlapping contacts
		with staggered contacts
④	2138	Roller lever 7H for safety duties

* Switches with 2 NO contacts are only suitable for positioning tasks!

Ordering details

EX-certified
screwed cable gland

EX-KLE-M20x1.5

Position switches

Plunger S

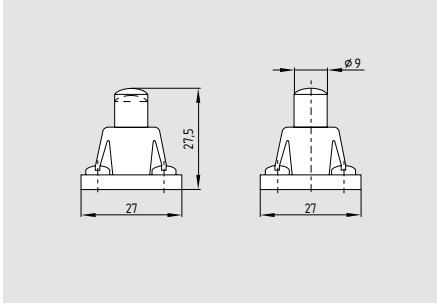

- Actuator type B to EN 50041
- Required actuating force
Slow action: 17 N
- Actuating speed with actuating angle 0° to switch axis: max. 0.5 m/s

Contact variants

Contacts/ Switch travel	Slow action	Slow action with overlapping contacts
1 NO / 1 NC	EX-TS 335-11Y 	EX-TS 335-11YUE
2 NC	EX-TS 335-02Y 	
2 NO	EX-TS 335-20Y 	

Roller plunger R

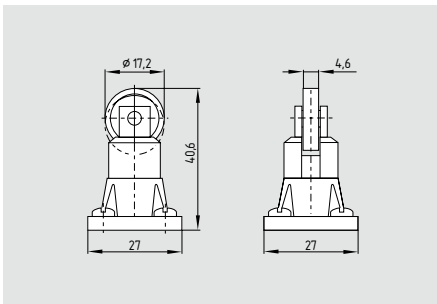

- Actuator type C to EN 50041
- Required actuating force
Slow action: 17 N
- Actuating speed with actuating angle 30° to switch axis: max. 0.5 m/s

Contact variants

Contacts/ Switch travel	Slow action	Slow action with overlapping contacts
1 NO / 1 NC	EX-TR 335-11Y 	EX-TR 335-11YUE
2 NC	EX-TR 335-02Y 	
2 NO	EX-TR 335-20Y 	

Position switches

Roller lever H

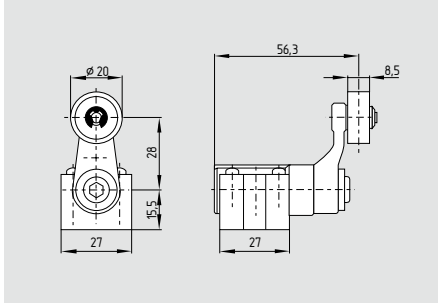

- Actuator type A to EN 50041
- Required actuating torque
Slow action: 31 Ncm
- Actuating speed with actuating angle 30° to switch axis: max. 2.5 m/s

Contact variants

Contacts/ Switch travel	Slow action	Slow action with overlapping contacts
1 NO / 1 NC	EX-T4VH 335-11Y 	EX-T4VH 335-11YUE
2 NC	EX-T4VH 335-02Y 	
2 NO	EX-T4VH 335-20Y 	

Rod lever 10H

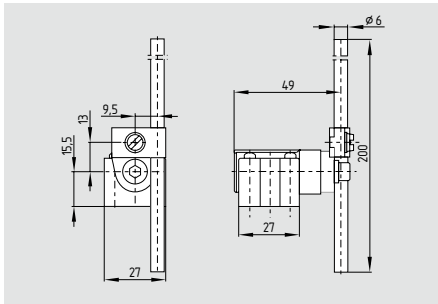

- **only for positioning tasks**
- Actuator type D to EN 50041
- Plastic rod
- Required actuating torque
Slow action: 31 Ncm
- Actuating speed with actuating angle 30° to switch axis: max. 2.5 m/s

Contact variants

Contacts/ Switch travel	Slow action	Slow action with overlapping contacts
1 NO / 1 NC	EX-T4V10H 335-11Y 	EX-T4V10H 335-11YUE
2 NC	EX-T4V10H 335-02Y 	
2 NO	EX-T4V10H 335-20Y 	

Position switches

Roller lever 7H

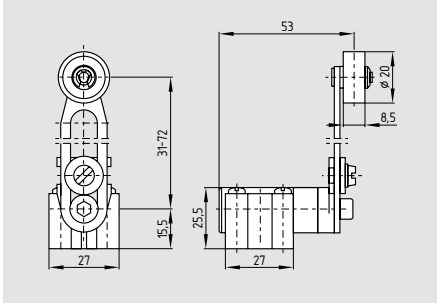

- only for positioning tasks
- Required actuating torque
- Slow action: 31 Ncm
- Actuating speed with actuating angle 30° to switch axis: max. 2.5 m/s

Contact variants

Contacts/ Switch travel	Slow action	Slow action with overlapping contacts
1 NO / 1 NC	EX-T4V7H 335-11Y 	EX-T4V7H 335-11YUE
2 NC	EX-T4V7H 335-02Y 	
2 NO	EX-T4V7H 335-20Y 	

7H-2138

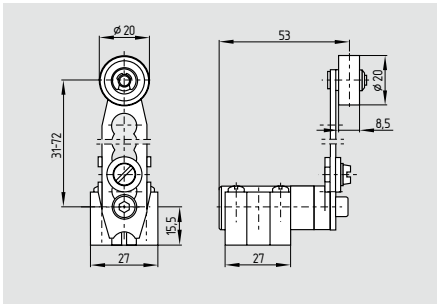

- for safety duties ⊕
- Required actuating torque
Slow action: 31 Ncm
- Actuating speed with actuating angle 30° to switch axis: max. 2.5 m/s

Contact variants

Contacts/ Switch travel	Slow action	Slow action with overlapping contacts
1 NO / 1 NC	EX-T4V7H 335-11Y-2138 	EX-T4V7H 335-11YUE-2138
2 NC	EX-T4V7H 335-02Y-2138 	
2 NO	EX-T4V7H 335-20Y-2138 	

Position switches

Offset roller lever 1K

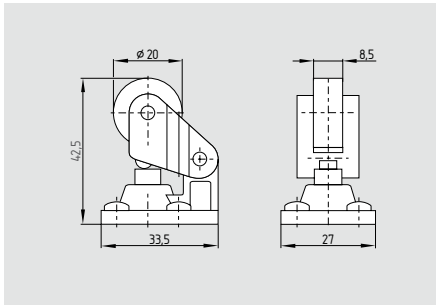

- Required actuating force
Slow action: 17 N
- Actuating speed with actuating angle 30°
to switch axis: max. 0.5 m/s

Contact variants

Contacts/ Switch travel	Slow action	Slow action with overlapping contacts
1 NO / 1 NC	EX-T1K 335-11Y 	EX-T1K 335-11YUE
2 NC	EX-T1K 335-02Y 	
2 NO	EX-T1K 335-20Y 	

Angle roller lever 3K

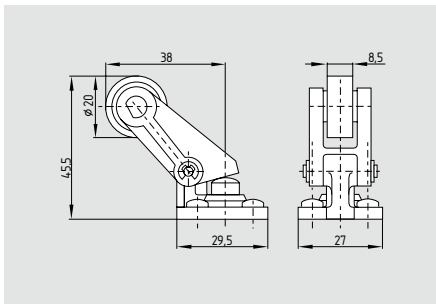

- Required actuating force
Slow action: 17 N
- Actuating speed with actuating angle 30°
to switch axis: max. 0.5 m/s
- Actuation parallel to axis of switch from
below

Contact variants

Contacts/ Switch travel	Slow action	Slow action with overlapping contacts
1 NO / 1 NC	EX-T3K 335-11Y 	EX-T3K 335-11YUE
2 NC	EX-T3K 335-02Y 	
2 NO	EX-T3K 335-20Y 	

Position switches

EX-T/M 441-...

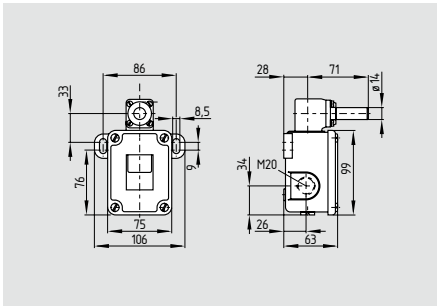

- Ex certified
- Metal enclosure
- Slow action, change-over contact with double break
- Snap action, change-over contact with double break
- 2 cable entries M20
- Protection class IP65, IP66 and IP67
- Suitable for heavy duty

Technical data

Equipment category: L II 2D
 Ex protection: Ex tD A21 IP65 T90°C X
 Standards: EN 60947-5-1; EN 61241-0, EN 61241-1
 Enclosure: Grey cast iron, galvanized and painted
 Protection class: IP65, IP66 and IP67 to EN 60529
 Contact material: silver, gold-flashed
 Switching system: Snap- and slow action with double break
 Contact type: Slow action: positive break NC contact A
 double break of 2 separated contact bridges
 Connection: screw terminals M 4
 Cable section: max. 2.5 mm² (incl. conductor ferrules)
 U_{imp} : Snap action: 4 kV; Slow action: 6 kV
 U_i : Slow action: 250 V; Snap action: 400 V
 I_{the} : 16 A
 I_e/U_e : Snap action: 4 A / 230 V; Slow action: 4 A / 400 V
 Utilisation category: AC-15
 Max. fuse rating: 16 A gG D-fuse
 Contact break: Snap action: max. 2 × 2.5 mm; Slow action: max. 2 × 6.0 mm
 Switchover time: Snap action: 35 ms
 Bounce duration: Snap action: 5 ms
 Ambient temperature: - 20 °C ... + 60 °C
 Mechanical life: 10 million operations
 Switching frequency: max. 3000/h
 Cable cross-section of the cable glands: min. Ø 7 mm; max. Ø 12 mm; L II 2D

Contact variants

1 NO / 1 NC contacts

Snap action

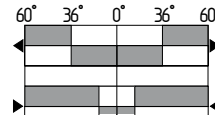

Slow action

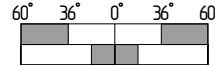

Approvals



Ordering details

EX-①441-11Y-②-1276-2

N°	Option	Description
①	M.	Snap action
	T.	Slow action
②	UE	Slow action with overlapping contacts

Ordering details

see page 84
 EX-certified screwed cable gland **EX-KLE-M20x1.5**
 EX-certified screwed cable gland **EX-KLE-M25x1.5**
 EX-certified screw plug **EX-VS-M20x1.5**
 EX-certified screw plug **EX-VS-M25x1.5**

see page 76
Actuator selection (actuators must be ordered separately)

Position switches

EX-T/M 250-...

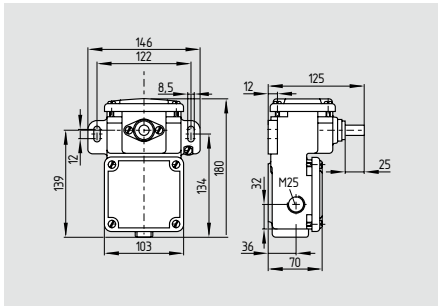

- Ex certified
- Metal enclosure
- Slow action, change-over contact with double break
- Snap action, change-over contact with double break
- 2 cable entries M25
- Protection class IP65, IP66 and IP67
- Suitable for heavy duty

Technical data

Equipment category: II 2D
 Ex tD A21 IP67 T90°C
 Standards: EN 60947-5-1; EN 61241-0, EN 61241-1
 Enclosure: Grey cast iron, galvanized and painted
 Protection class: IP65, IP66 and IP67 to EN 60529
 Contact material: silver, gold-flashed
 Contact type: snap action, change-over contact, slow action positive break NC contact \ominus
 double break with 2 separate contact bridges
 Switching system: Snap- and slow action
 Connection: screw terminals M 4
 Cable section: max. 2.5 mm² (incl. conductor ferrules)
 U_{imp} : 6 kV
 U_i : 500 V
 I_{the} : 16 A
 I_g/U_g : 4 A / 400 VAC
 Utilisation category: AC-15
 Max. fuse rating: 16 A gG D-fuse
 Contact break: Snap action: max. 2 x 2.5 mm
 Slow action: max. 2 x 2 mm
 Switchover time: 35 ms
 Bounce duration: 5 ms
 Ambient temperature: -20 °C ... +60 °C
 Mechanical life: 10 million operations
 Switching frequency: max. 3000/h
 Cable cross-section of the cable glands: min. \varnothing 14 mm
 max. \varnothing 18 mm
 II 2D

Contact variants

1 NO / 1 NC contacts

Snap action

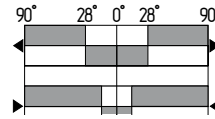

Slow action

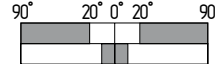

2 NO / 2 NC contacts

Snap action

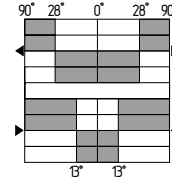

Slow action

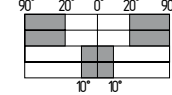

Approvals



Ordering details

EX-①250-②Z-1276-2

No.	Option	Description
①	M.	Snap action
	T.	Slow action
②	11	1 NO/1 NC contacts
	22	2 NO/2 NC

Ordering details

see page 84
 EX-certified screwed cable gland **EX-KLE-M20x1.5**
 EX-certified screwed cable gland **EX-KLE-M25x1.5**
 EX-certified screw plug **EX-VS-M20x1.5**
 EX-certified screw plug **EX-VS-M25x1.5**

see page 76
Actuator selection (actuators must be ordered separately)

Position switches

EX-TS 064-...

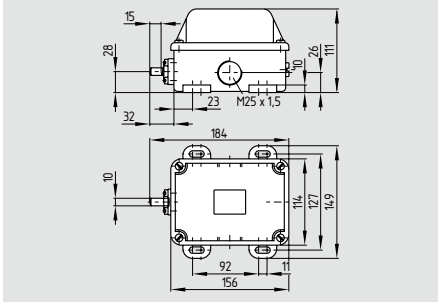

- Ex certified
- Metal enclosure
- 3 or 4 contact, slow action ⊖
- Roller levers J and X can be subsequently fitted at plunger S
- Actuator head can be repositioned in steps 4 x 90°
- 2 cable entries M25
- Protection class IP65, IP66 and IP67

Actuation from the side of the plunger should be avoided, since this reduces the mechanical life of the position switch. Recommendation: use roller lever

Technical data

Equipment category: II 2D
 Ex protection: Ex tD A21 IP65 T90°C X
 Standards: EN 60947-5-1, EN 61241-0, EN 61241-1
 Enclosure: Grey cast iron, galvanized and painted
 Actuating speed: max. 1 m/s, min. 0.01 m/s at the plunger
 Protection class: IP65, IP66 and IP67 to EN 60529
 Contact material: silver, gold-flashed
 Switching system: slow action with double break
 Contact type: NC contact positive break ⊖
 Connection: screw terminals M 5
 Cable section: max. 4 mm² (incl. conductor ferrules)
 U_{imp} : 6 kV
 U_i : 500 V
 I_{the} : 25 A
 I_e/U_e : 25 A / 400 VAC
 Utilisation category: AC-15
 Max. fuse rating: 16 A gG D-fuse
 Allowed horsepower: at 400 V 3-phase 5.5 kW (squirrel-cage rotor n = 1500 rpm)
 Contact break: max. 2 x 4 mm
 Ambient temperature: - 20 °C ... + 60 °C
 Mechanical life: 1 million operations
 Switching frequency: max. 1000/h
 Actuating angle: max. 20°
 Weight: approx. 3.2 kg
 Cable cross-section of the cable glands: min. Ø 14 mm max. Ø 18 mm
 II 2D

Contact variants

Plunger S
1 NO contact / 1 NC contact
 0 4,5 6 15

Offset roller lever J
1 NO contact / 1 NC contact
 0 9 12 29

Offset roller lever X
1 NO contact / 1 NC contact
 0 17 24 60

Dust zone 21/22

Approvals



Ordering details

EX-T① 064-②Y-③-1276-2

N°	Option	Description
①		For the appropriate actuator: see page 72
②	03	3 NC contacts
	12	1 NO/2 NC
	21	2 NO/1 NC
	30	3 NO contacts
	04	4 NC contacts
	13	1 NO/3 NC
	22	2 NO/2 NC
	31	3 NO/1 NC
	40	4 NO contacts
③	UE	Slow action with overlapping contacts
	H	with staggered contacts

Force-travel diagram

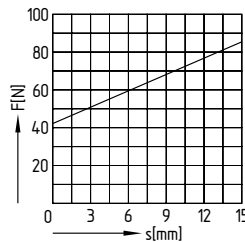

Ordering details

EX-certified screwed cable gland **EX-KLE-M25x1.5**
 EX-certified screw plug **EX-VS-M25x1.5**

Position switches

EX-MS 064-...

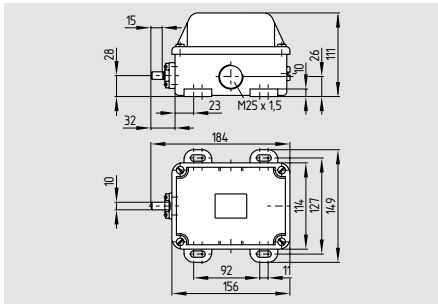

- Ex certified
- Metal enclosure
- 3 or 4 contact, snap action with double break
- Roller levers J and X can be subsequently fitted at plunger S
- Actuator head can be repositioned in steps 4 x 90°
- 2 cable entries M25
- Protection class IP65, IP66 and IP67

Actuation from the side of the plunger should be avoided, since this reduces the mechanical life of the position switch. Recommendation: use roller lever

Technical data

Equipment category: Ex II 2D
 Ex protection: Ex tD A21 IP65 T90°C X
 Standards: EN 60947-5-1, EN 61241-0, EN 61241-1
 Enclosure: Grey cast iron, galvanized and painted
 Protection class: IP65, IP66 and IP67 to EN 60529
 Contact material: silver, gold-flashed
 Switching system: snap action with double break
 Contact type: change-over contact, galvanically separated contact bridges
 Connection: screw terminals M 5
 Cable section: max. 4 mm² (incl. conductor ferrules)
 U_{imp} : 6 kV
 U_i : 500 V
 I_{the} : 25 A
 I_e/U_e : 25 A / 400 VAC
 Utilisation category: AC-15
 Max. fuse rating: 25 A gG D-fuse
 Allowed horsepower: at 400 V 3-phase 5.5 kW (squirrel-cage rotor n = 1500 rpm)
 Contact break: max. 2 x 4 mm
 Ambient temperature: - 20 °C ... + 60 °C
 Mechanical life: 30000 operations
 Switching frequency: max. 1000/h
 Actuating speed: max. 1 m/s, min. 0.01 m/s at the plunger
 Actuating angle: max. 20°
 Weight: approx. 3.6 kg
 Cable cross-section of the cable glands: min. Ø 14 mm max. Ø 18 mm
 Ex II 2D

Contact variants

Plunger S

1 NC contact

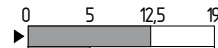

1 NO contact

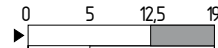

Offset roller lever J

1 NC contact



1 NO contact

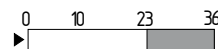

Offset roller lever X

1 NC contact



1 NO contact

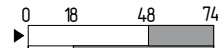

Approvals



Ordering details

EX-M① 064-②Y-1276-2

No.	Option	Description
①		For the appropriate actuator: see page 72
②	03	3 NC contacts
	12	1 NO/2 NC
	21	2 NO/1 NC
	30	3 NO contacts
	04	4 NC contacts
	13	1 NO/3 NC
	22	2 NO/2 NC
	31	3 NO/1 NC
	40	4 NO contacts

Force-travel diagram

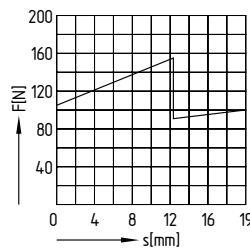

Ordering details

EX-certified
 screwed cable gland
 EX-certified
 screw plug

EX-KLE-M25x1.5

EX-VS-M25x1.5

Position switches

System components

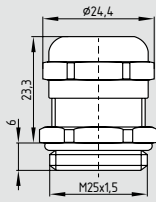

EX-certified screwed cable gland

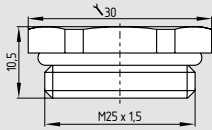

EX-certified screw plug

Plunger S

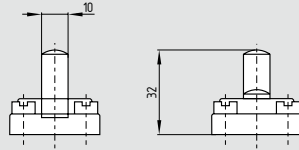

- Actuating speed 1 m/s with an actuating angle of max. 20°
- Roller levers J and X can be subsequently fitted at plunger S

Actuation from the side of the plunger should be avoided, since this reduces the mechanical life of the position switch.

Recommendation: use roller lever

Offset roller lever J

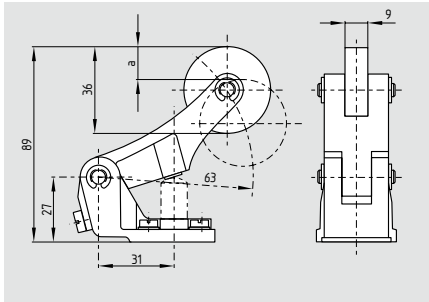

- Actuating speed max. 0.5 m/s with an actuating angle of $a = 45^\circ$ and $b = 30^\circ$
- Plastic roller (metal roller on request)
- Actuator head can be repositioned in steps $4 \times 90^\circ$
- Available with rubber roller, ordering suffix -1

Actuation from the right side of the plunger should be avoided, since this reduces the mechanical life of the position switch.

Offset roller lever X

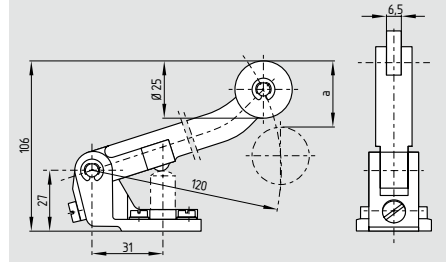

- Actuating speed max. 0.5 m/s with an actuating angle of $\alpha = 45^\circ$ and $\beta = 30^\circ$
- Plastic roller (metal roller on request)
- Actuator head can be repositioned in steps $4 \times 90^\circ$

Actuation from the right side of the plunger should be avoided, since this reduces the mechanical life of the position switch.

Note

Legend

- α : Actuating angle from right of switch axis
- β : Actuating angle from left of switch axis

Ordering details

EX-certified screwed cable gland	EX-KLE-M25x1.5
EX-certified screw plug	EX-VS-M25x1.5

Position switches

Roller lever L

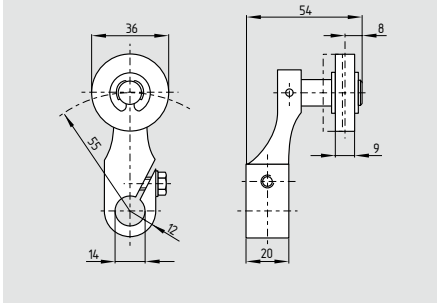

- Actuating speed max. 3 m/s with an actuating angle of α and $\beta = 30^\circ$
- Plastic roller
- Continuous adjustment of lever position 360°
- Splined shaft and lever available with 10° tooting
- Available with metal roller
- Available with rubber roller, ordering suffix -1

Roller lever V

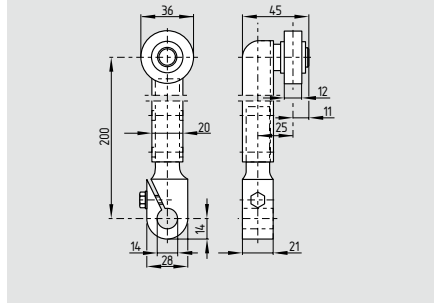

- Actuating speed max. 3 m/s with an actuating angle of α and $\beta = 30^\circ$
- Plastic roller
- Continuous adjustment of lever position 360°
- Splined shaft and lever available with 10° tooting
- Available with metal roller
- Available with rubber roller, ordering suffix -1

Fork lever C

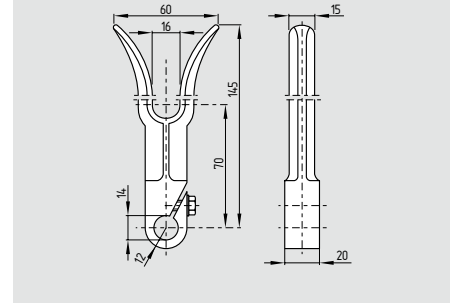

- Continuous adjustment of lever position 360°
- Splined shaft and lever available with 10° tooting

Roller lever A

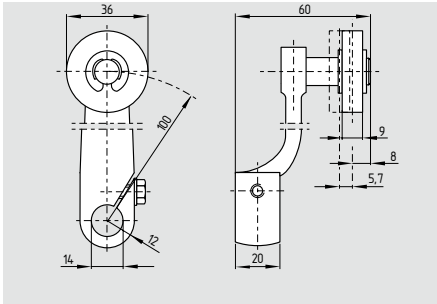

- Actuating speed max. 3 m/s with an actuating angle of α and $\beta = 30^\circ$
- Plastic roller
- Continuous adjustment of lever position 360°
- Splined shaft and lever available with 10° tooting
- Available with metal roller
- Available with rubber roller, ordering suffix -1

Pull lever Z

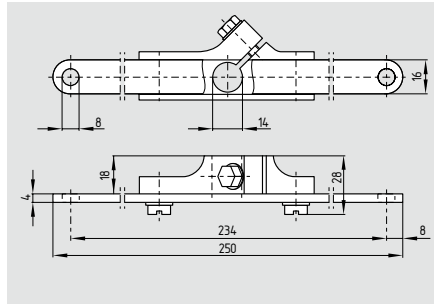

- Continuous adjustment of lever position 360°
- Splined shaft and lever available with 10° tooting

Offset roller lever 4D

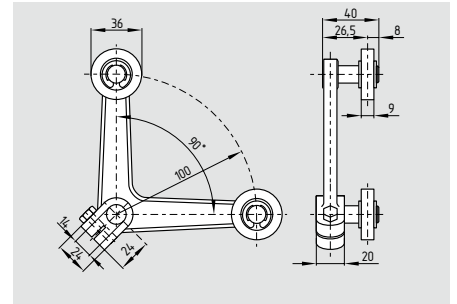

- Continuous adjustment of lever position 360°
- Splined shaft and lever available with 10° tooting

Roller lever 2A

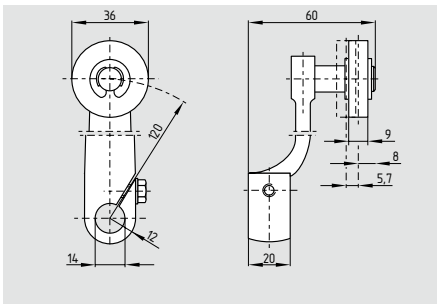

- Actuating speed max. 3 m/s with an actuating angle of α and $\beta = 30^\circ$
- Plastic roller
- Continuous adjustment of lever position 360°
- Splined shaft and lever available with 10° tooting
- Available with metal roller
- Available with rubber roller, ordering suffix -1

Pull lever 2Z

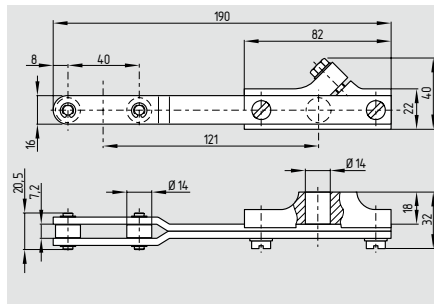

- Continuous adjustment of lever position 360°
- Splined shaft and lever available with 10° tooting

Legend

α : Actuating angle from right of switch axis
 β : Actuating angle from left of switch axis

Safety switch for hinged guards

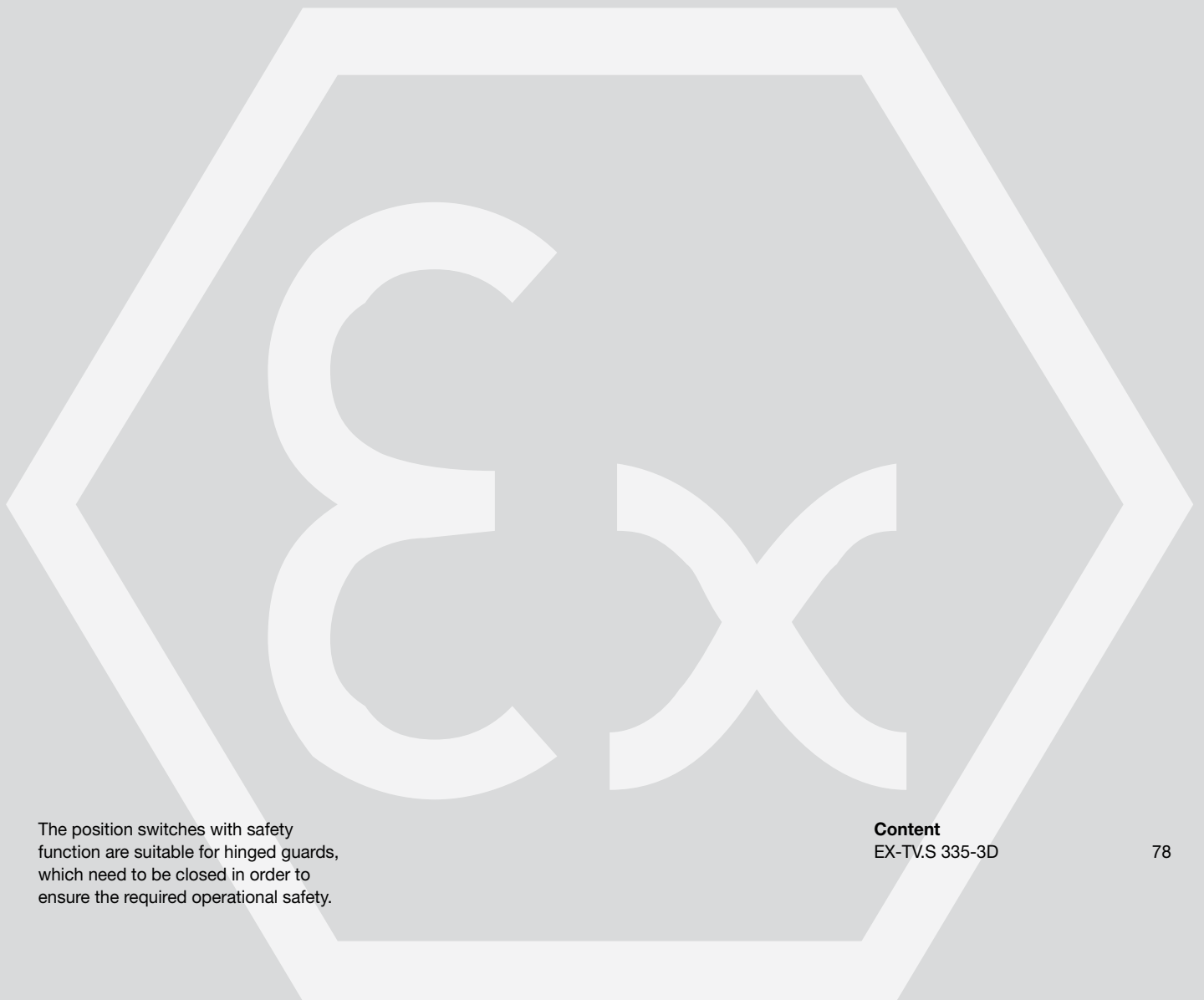

The position switches with safety function are suitable for hinged guards, which need to be closed in order to ensure the required operational safety.

Content
EX-TV.S 335-3D

Safety switch for hinged guards

EX-TV.S 335-3D

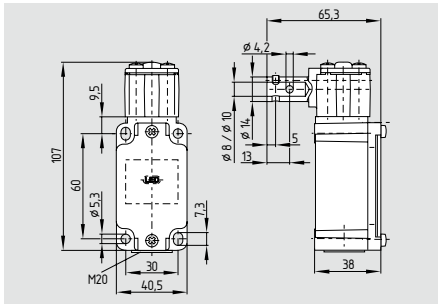

- Metal enclosure
- Good resistance to oil and petroleum spirit
- The actuator can be turned by 4 x 90° using Torx T 20 screwdriver with pin
- Actuator shaft can be turned 360°
- 1 Cable entry M20
- Shaft bore Ø 8 and 10 mm

Technical data

Equipment category: L II 3D
 Ex protection: Ex tD A22 IP67 T90°C X
 Standards: EN 60947-5-1; EN 61241-0;
 EN 61241-1; BG-GS-ET-15
 Enclosure: light-alloy diecast, paint finish
 Actuator: stainless steel 1.4301
 Max. impact energy: 4 J
 Actuating speed: max. 1 m/s
 Protection class: IP67 to EN 60529
 Contact material: Silver
 Contact types: Change-over contact

with double break type Zb,
 3 NC contacts with galvanically separated contact bridges
 Switching system: A EN 60947-5-1, slow action, positive break NC contact

Connection: screw terminals
 Cable section: max. 2.5 mm², min. 0.75 mm² (incl. conductor ferrules)

Cable entry: M20
 U_{imp}: 6 kV
 U_i: 500 V
 I_{the}: 10 A
 Utilisation category: AC-15; DC-13
 I_e/U_e: 4 A / 230 VAC
 4 A / 24 VDC
 Max. fuse rating: 6 A gG D-fuse
 Positive break travel: 10.7 mm
 Positive break force: each NC contact 5 N
 Ambient temperature: -20 °C ... +60 °C
 Mechanical life: > 1 million operations
 Switching frequency: max. 1000/h
 Shaft bore: Ø 8 mm / 10 mm
 Positive break angle: 7°
 Positive break torque: 0.6 Nm
 B_{10d} value to EN ISO 13849-1: 20 million
 Cable cross-section of the cable glands: min. Ø 7 mm
 max. Ø 12 mm
 L II 2D

Classification:
 Standards: EN ISO 13849-1
 B_{10d} Opener (NC): 20,000,000
 Service life: 20 years

$$MTTF_d = \frac{B_{10d}}{0,1 \times n_{op}} \quad n_{op} = \frac{d_{op} \times h_{op} \times 3600 \text{ s/h}}{t_{cycle}}$$

Contact variants

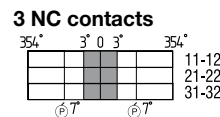
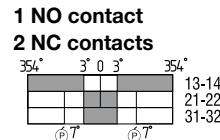
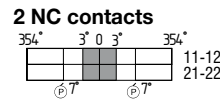
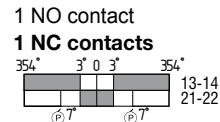

Approvals



Ordering details

Ex-TV¹S 335-2²Z-3

No.	Option	Description
①	8	Shaft bore Ø 8 mm
	10	Shaft bore Ø 10 mm
②	02	2 NC contacts
	03	3 NC contacts
③	11	1NO/1NC contact
	12	1NO/2NC contacts
③		Cable entry M20

Note

Closed guard device = 0° in contact switch travel diagrams.
 The switch is in resting position.

- Adjustment tool: locking screw to fix, shaft pre-drilled to pin
- Universal joint available to compensate for axial displacement only for Ø 10 mm

Safety switch for hinged guards

System components

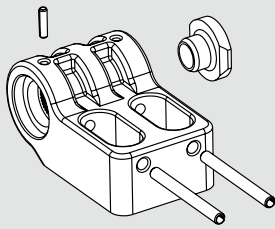

Fixed hinge F

System components

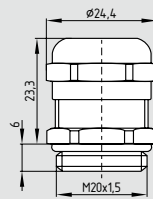

EX-certified screwed cable gland

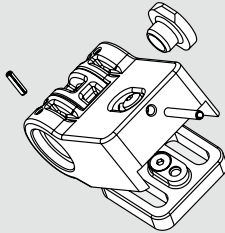

Adjustable hinge L

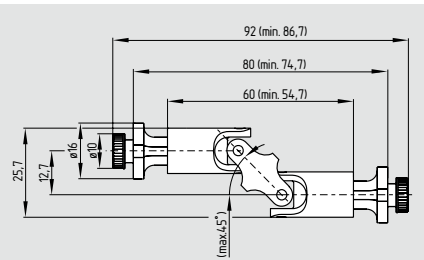

Universal joint K1

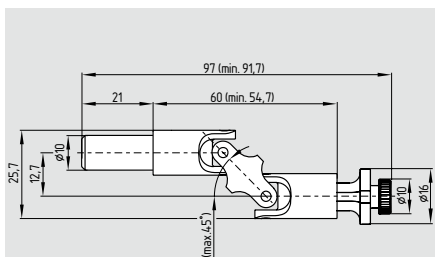

Universal joint K2

Ordering details

Fixed hinge F **101138414**
Adjustable hinge L **101138413**

Universal joint K1 **101138412**
(in combination with hinge F or L) only for
TV8S 521

Universal joint K2 **101147448**
for ES 13 SB, ES 95 SB-10mm, TV 10S 335
and TV10S 355

Ordering details

EX-certified
screwed cable gland **EX-KLE-M20x1.5**

Ordering details

Datenblatt

- Metallgehäuse
- Leitungseinführung M 16 x 1,5
- weitgehend öl- und benzinsbeständig
- für links oder rechts angeschlagene Türen
- 141 mm x 115 mm x 21,5 mm
- einfache Montage, passend für alle gängigen Profilsysteme (30 ... 60 mm)
- Einbaustecker M 16 x 1,5, 10-polig, oben

Bestelldaten	
Produkt-Typbezeichnung	TVS 410ST5-11/11UN
Artikelnummer	1183876
EAN Code	4030661320465

Zulassung	
Zulassung	BG

Sicherheitsbetrachtung	
Vorschriften	EN ISO 13849-1
B ₁₀₀ Öffner (NC)	20 Millionen Schaltspiele
B ₁₀₀ Schließer (NO)	1 Million Schaltspiele
Gebrauchsdauer TM	20 Jahre

Allgemeine Daten	
Produkt-Name	TVS 410
Vorschriften	IEC/EN 60947-5-1, BG-GS-ET-15
Richtlinienkonformität (JIN)	Ja
Werkstoffe	
- Werkstoff des Gehäuses	Zink-Druckguss

Produkthierarchie

- Sicheres Schalten und Erfassen
 - Sicherheitschalter mit getrenntem Betätiger
 - Sicherheitszuhaltung
 - Positionsschalter
 - Sicherheitschalter für drehbare Schutzeinrichtungen
 - Scharnier-Sicherheitschalter
 - ES 13 SB
 - ES 95 SB
 - T.V10S 500
 - TV.S 335
 - TV.S 355
 - TV/BS 521
 - TVS 400
 - TVS 410
 - TVS 410ST5-11/11UN**
 - TVS 410CC-11/11A
 - TVS 410CC-11/11I
 - TVS 410CC-11/11U
 - TVS 410CC-11/11AN
 - TVS 410CC-11/11IN
 - TVS 410CC-11/11UN
 - TVS 410SK-11/11A
 - TVS 410SK-11/11I
 - TVS 410SK-11/11U
 - TVS 410SK-11/11AN
 - TVS 410SK-11/11IN
 - TVS 410SK-11/11UN
 - TVS 410ST1-11/11A
 - TVS 410ST1-11/11AN
 - TVS 410ST1-11/11I
 - TVS 410ST1-11/11IN
 - TVS 410ST1-11/11U
 - TVS 410ST1-11/11UN
 - TVS 410ST1-11/01A
 - TVS 410ST1-11/01AN
 - TVS 410ST1-11/01I
 - TVS 410ST1-11/01IN
 - TVS 410ST1-11/01U
 - TVS 410ST1-11/01UN
 - TVS 410ST2-11/01A
 - TVS 410ST2-11/01AN
 - TVS 410ST2-11/01I
 - TVS 410ST2-11/01IN
 - TVS 410ST2-11/01U
 - TVS 410ST2-11/01UN
 - TVS 410ST2-11/11A

Detailed technical information at:
www.schmersal.com

Belt alignment switch / Slack-wire switch



Belt alignment switches and slack-wire switches are suitable for use on material handling equipment. The belt alignment switch is actuated, when the conveyor belt becomes misaligned. Depending on the plant set-up, this signal can be used to switch off the machinery or plant either to provide an automatic correction of the belt alignment.

Content

EX-T/M 441-...

82

EX-T/M 250-...

83

Belt alignment switch / Slack-wire switch

EX-T/M 441-...

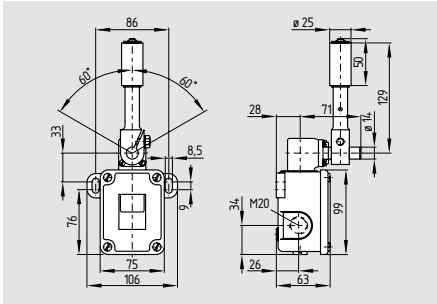
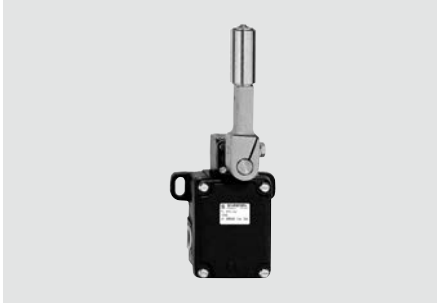

- Ex certified
- Metal enclosure
- Slow action, change-over contact with double break
- Snap action, change-over contact with double break
- 2 cable entries M20
- Belt alignment lever available with different roller lengths
- Protection class IP65, IP66 and IP67
- Suitable for heavy duty

Technical data

Equipment category: Ex II 2D
 Ex protection: Ex tD A21 IP65 T90°C X
 Standards: EN 60947-5-1; EN 61241-0, EN 61241-1
 Enclosure: Grey cast iron, galvanized and painted
 Protection class: IP65, IP66 and IP67 to EN 60529
 Contact material: silver, gold-flashed
 Switching system: Snap- and slow action with double break
 Contact types: Slow action: positive break NC contact \ominus ;
 double break of 2 separated contact bridges
 Connection: screw terminals M 4
 Cable section: max. 2.5 mm² (incl. conductor ferrules)
 U_{imp} : snap action: 4 kV; slow action: 6 kV
 U_i : slow action: 250 V; snap action: 400 V
 I_{the} : 16 A
 I_e/U_e : Snap action: 4 A / 230 V; Slow action: 4 A / 400 V AC-15
 Utilisation category: 16 A gG D-fuse
 Max. fuse rating: Snap action: max. 2 x 2.5 mm; Slow action: max. 2 x 6.0 mm
 Contact break: Snap action: 35 ms; Slow action: 5 ms
 Switchover time: Snap action: 35 ms; Slow action: 5 ms
 Bounce duration: Snap action: 5 ms
 Ambient temperature: - 20 °C ... + 60 °C
 Mechanical life: 10 million operations
 Switching frequency: max. 3000/h
 Cable cross-section of the cable glands: min. $\text{Ø } 7 \text{ mm}$; max. $\text{Ø } 12 \text{ mm}$
 Ex II 2D

Contact variants

1 NO contact
1 NC contacts

Snap action

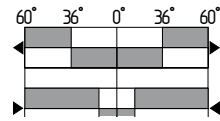

Slow action

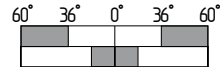

Approvals



Ordering details

EX-①441-11Y-②-③-1276-2

No.	Option	Description
①	M. T.	Snap action Slow action
②	UE	Slow action with overlapping contacts
③		Actuator selection, see page 84

Belt alignment switch / Slack-wire switch

EX-T/M 250-...

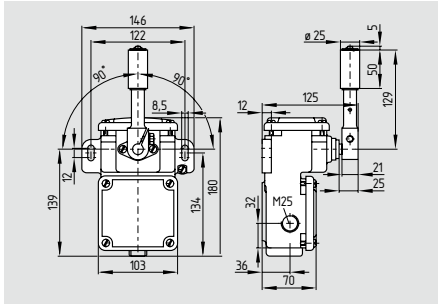

- Ex certified
- Metal enclosure
- Slow action, change-over contact with double break
- Snap action, change-over contact with double break
- 2 cable entries M25
- Belt alignment lever available with different roller lengths
- Protection class IP65, IP66 and IP67
- Suitable for heavy duty

Technical data

Equipment category: II 2D
 Ex protection: Ex tD A21 IP67 T90°C X
 Standards: EN 60947-5-1; EN 61241-0, EN 61241-1
 Enclosure: Grey cast iron, galvanized and painted
 Protection class: IP65, IP66 and IP67 to EN 60529
 Contact material: silver, gold-flashed
 Contact types: snap action, change-over contact, slow action positive break NC contact \ominus double break with 2 separate contact bridges
 Switching system: Snap- and slow action
 Connection: screw terminals M 4
 Cable section: max. 2.5 mm² (incl. conductor ferrules)
 U_{imp} : 6 kV
 U_i : 500 V
 I_{the} : 16 A
 I_e/U_e : 4 A / 400 VAC
 Utilisation category: AC-15
 Max. fuse rating: 16 A gG D-fuse
 Contact break:
 Snap action: max. 2 x 2.5 mm
 Slow action: max. 2 x 2 mm
 Switchover time: 35 ms
 Bounce duration: 5 ms
 Ambient temperature: -20 °C ... +60 °C
 Mechanical life: 10 million operations
 Switching frequency: max. 3000/h
 Cable cross-section of the cable glands: min. \varnothing 14 mm max. \varnothing 18 mm
 II 2D

Contact variants

1 NO contact
1 NC contacts

Snap action

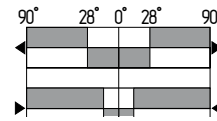

Slow action

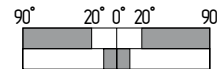

2 NO contact
2 NC contacts

Snap action

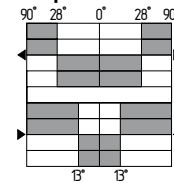

Slow action

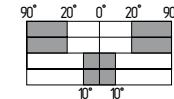

Approvals



Ordering details

EX-①250-②Z-③-1276-2

No.	Option	Description
①	M. T.	Snap action Slow action
②	11 22	1 NO/1 NC contact 2 NO/2 NC contacts
③		Actuator selection, see page 84

Belt alignment switch / Slack-wire switch

Dust zone 21, 22

System components

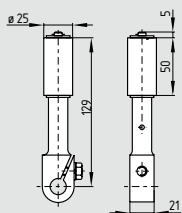

Belt alignment lever 243

System components

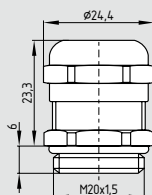

EX-certified screwed cable gland M20

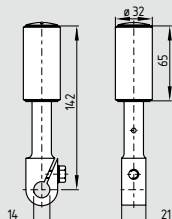

Belt alignment lever 966

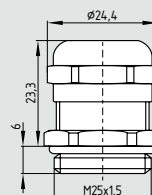

EX-certified screwed cable gland M25

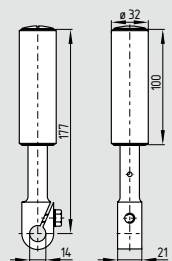

Belt alignment lever 1224

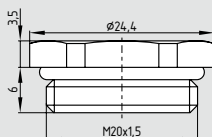

EX-certified screw plug M20

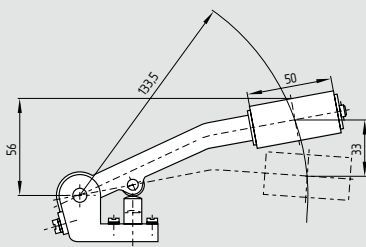

Slack-wire lever type 14

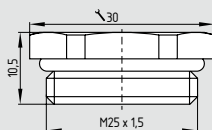

EX-certified screw plug M25

Ordering details

Belt alignment lever
 243 **Ordering suffix -243**
 966 **Ordering suffix -966**
 1224 **Ordering suffix -1224**
 Slack-wire lever (only
 in combination with
 EX-T/M 441) type 14 **suffix -type 14**

Ordering details

EX-certified
 screwed cable gland **EX-KLE-M20x1.5**
 EX-certified
 screwed cable gland **EX-KLE-M25x1.5**
 EX-certified
 screw plug **EX-VS-M20x1.5**
 EX-certified
 screw plug **EX-VS-M25x1.5**

Pull-wire emergency-stop switches



Pull-wire emergency stop switches are mounted on machines and sections of plants which cannot be protected by guards. In contrast to mushroom head emergency stop push buttons, on pull-wire switches the emergency stop command can be initiated from any point on the wire.

Content

Ex-ZQ 900-3D

86

EX-T3Z 068-...

88

Pull-wire emergency-stop switches

Ex-ZQ 900-3D

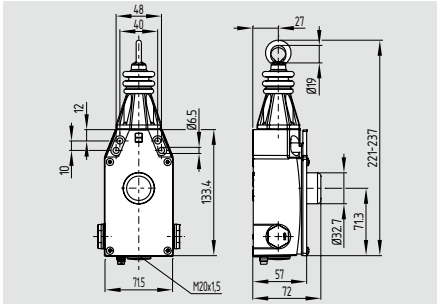

- to EN ISO 13850 / IEC 60947-5-5
- Metal enclosure
- 4 contacts
- position indication
- Robust design
- Large wiring compartment
- 3 cable entries M20
- One tension force for wire lengths from 5 to 50 m
- Wire up to 50 m long
- Reset pushbutton
- Twisting of towing eye not possible
- External watertight collar
- Wire pull and breakage detection
- Stainless
- Including Ex-certified screwed cable gland
- Including Ex-certified screw plug

Technical data

Equipment category: Ex II 3D
 Ex protection: $\text{Ex tD A22 IP67 T100}^\circ\text{C}$
 Standards: IEC/EN 60947-5-1;
 IEC/EN 60947-5-5;
 EN 61241-0 EN 61241-1;
 EN ISO 13850
 Enclosure: zinc die-cast, enamel finish
 Cover: Steel
 Max. impact energy: 7 J
 Protection class: IP67 to IEC/EN 60529
 Contact material: Silver
 Contact types: 1 NC / 1 NO or 2 NC / 2 NO
 or 3 NC / 1 NO or 2 NC or 4 NC
 Switching system: \ominus IEC 60947-5-1
 snap action, NC contacts
 with positive break
 Connection: Screw terminals
 Cable section: max. 2.5 mm²
 (incl. conductor ferrules)
 Cable entry: 3x M20
 U_{imp} : 6 kV
 U_i : 500 V
 I_{the} : 4 A
 Utilisation category: AC-15, DC-13
 I_e/U_e : 4 A / 230 VAC;
 1 A / 24 VDC
 Max. fuse rating: 6 A gG D-fuse
 Ambient temperature: $-20^\circ\text{C} \dots +55^\circ\text{C}$
 Mechanical life: > 1 million operations
 Max. wire length: 50 m
 (Please observe the
 ambient temperature
 range and the wire supports)
 Features: wire pull and breakage detection
 Cable cross-section
 of the cable glands: min. $\text{Ø } 7 \text{ mm}$
 max. $\text{Ø } 12 \text{ mm}$
 Ex II 2D
Classification:
 Standards: EN ISO 13849-1
 B_{10d} Opener (NC): 100.000
 Service life: 20 years

$$\text{MTTF}_d = \frac{B_{10d}}{0,1 \times n_{op}} \quad n_{op} = \frac{d_{op} \times h_{op} \times 3600 \text{ s/h}}{t_{\text{cycle}}}$$

Contact variants

1 NO/1 NC contact

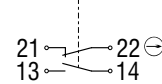

2 NC contacts

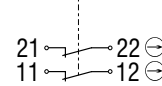

1 NO/3 NC contacts

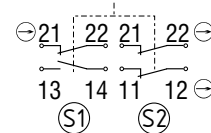

2 NO/2 NC contacts

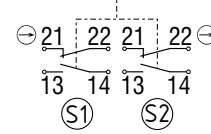

4 NC contacts

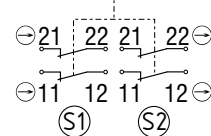

Approvals



Ordering details

EX-ZQ 900-①-3D

No.	Option	Description
①	11	1 NO/1 NC contact
	13	1 NO/3 NC contacts
	22	2 NO/2 NC contacts
	02	2 NC contacts
	04	4 NC contacts

Note

Recommended cable lengths for pull-wire
 Emergency-Stop switches in relation to the
 range of ambient temperature.
 At 5 m distance intermediate wire supports are
 required, see accessories

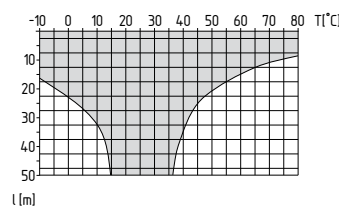

Ordering details

EX-certified
 screwed cable gland
 EX-certified
 screw plug
 (not represented)

EX-KLE-M20x1.5

EX-VS-M20x1.5

Pull-wire emergency-stop switches

Mode of operation

Not actuated

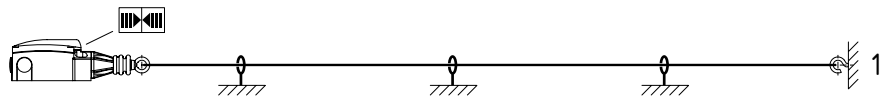

Wire pull detection

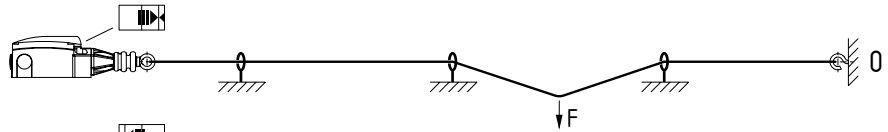

Wire breakage detection

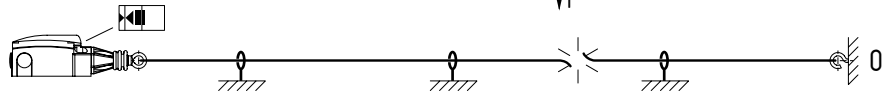

Wire pull and breakage detection

Mounting instructions

- 1 = Wire rope
- 2 = eyebolt
- 3 = nut
- 4 = Wire clamp
- 5 = tensioner
- 6 = wire thimble
- 7 = shackle
- 8 = wire tensioner

A = position indication
B = emergency-stop button

One-side operation

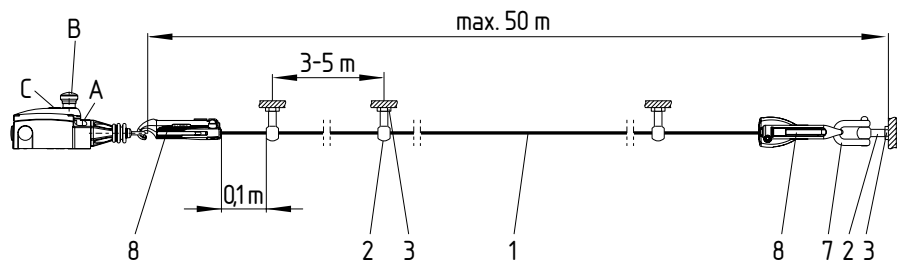
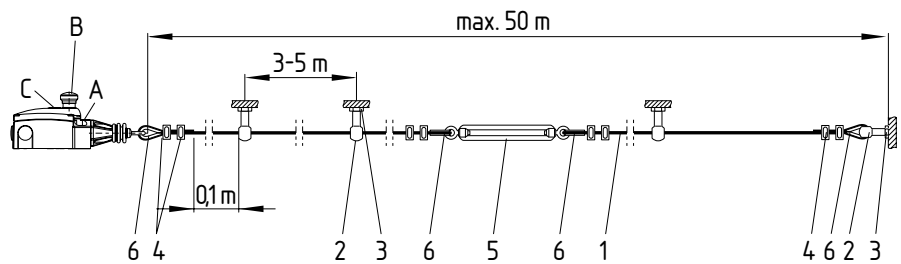

Mounting instructions

Note:

As the thimbles are subject to deformation in case of wire pull, the wire should be pulled several times after fitting. After that, the wire must be re-tensioned using the eyebolt or the tensioner.

Thimble deformation

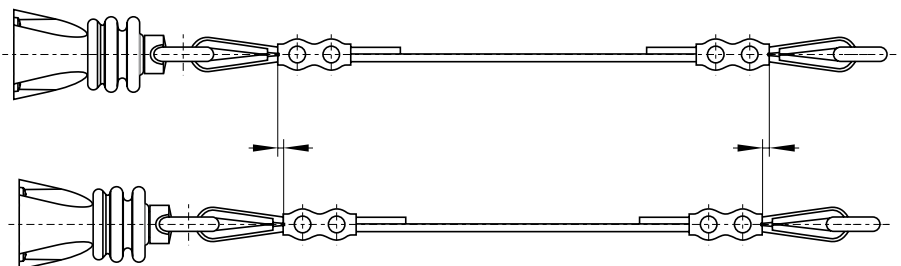

Pull-wire emergency-stop switches

EX-T3Z 068-...

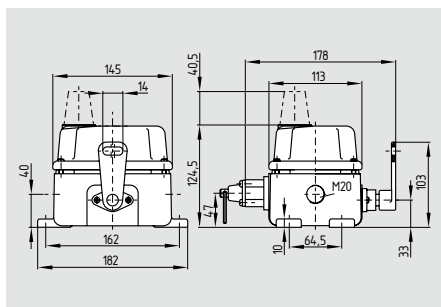

- Ex certified
- to EN ISO 13850 / EN 60947-5-5
- Metal enclosure
- Up to 6 contacts
- Robust design
- 2 cable entries M20
- Low actuating force
- Wire up to 2 x 50 m long
- Reset by pull ring

Technical data

Equipment category: II 2D
 Ex protection: Ex tD A21 IP65 T90°C X
 Standards: EN 60947-5-1; EN 60947-5-5;
 EN ISO 13850; EN 61241-0,
 EN 61241-1

Enclosure: Grey cast iron, painted
 Cover: Grey cast iron, painted
 Protection class: IP65 and IP66
 to EN 60529

Contact material: silver, gold-flashed
 Contact types: Change-over contact
 with double break, max.
 3 NO and 3 NC contacts

Switching system: \ominus IEC 60947-5-1
 snap action, NC contacts
 with positive break

Connection: Screw terminals
 Cable section: max. 1.5 mm², min. 0.75 mm²
 solid and stranded wire with conductor ferrules
 Cable entry: 2 x M 20

U_{imp} : 4 kV
 U_i : 250 VAC
 I_{the} : 10 A
 Utilisation category: AC-15, DC-13
 I_e/U_e : 2.5 A / 230 VAC
 6 A / 24 VDC

Max. fuse rating: 6 A gG D-fuse
 Positive break torque: 1.8 Nm
 Angle for positive break travel: 32°
 Positive break force: 50 N
 Actuating force: max. 50 N,
 (30 N in wire direction)

Ambient temperature: -20 °C ... +60 °C
 Mechanical life: 50000 operations
 Max. wire length: 2 x 50 m
 Features: wire pull and breakage detection
 Cable cross-section
 of the cable glands: min. Ø 7 mm
 max. Ø 12 mm
 II 2D

Classification:

Standards: EN ISO 13849-1
 B_{10d} Opener (NC): 100,000
 Service life: 20 years

$$MTTF_d = \frac{B_{10d}}{0,1 \times n_{op}} \quad n_{op} = \frac{d_{op} \times h_{op} \times 3600 \text{ s/h}}{t_{cycle}}$$

Contact variants

1 NO contact

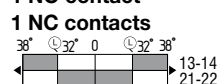

2 NO contact

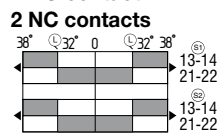

3 NO contact

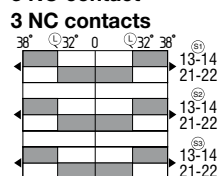

Approvals



Ordering details

EX-T3Z 068-①YR-1637

No.	Option	Description
①	11	1NO/1NC contact
	22	2NO/2NC contacts
	33	3NO/3NC contacts

Note

At 3 m distance intermediate wire supports are required, see accessories

Ordering details

EX-certified
 screwed cable gland **EX-KLE-M20x1.5**
 EX-certified
 screw plug **EX-VS-M20x1.5**

Pull-wire emergency-stop switches

System components	System components	System components
 <p>Eyebolt</p>	 <p>Pulley</p>	 <p>Tension spring</p>
 <p>Wire clamp</p>	 <p>Tensioner</p>	 <p>S 900 wire tensioner</p>
 <p>Duplex wire clamp</p>	 <p>Wire rope</p>	 <p>Shackle</p>
 <p>Wire thimble</p>	 <p>Wire unit complete</p>	

Ordering details	Ordering details	Ordering details
<p>Eyebolt BM 10 x 40 101084928 BM 8 x 70 (stainless steel) 101192471 Wire clamp 3 mm (stainless steel) 101203477 Duplex wire clamp 3 mm (stainless steel) 101190917 Wire thimble 4 mm (stainless steel) 101203475 Egg-shaped wire clamp (without Images) 101077072</p>	<p>Pulley (stainless steel) 101192433 Tensioner M6 101087930 Wire rope per m on request Wire unit complete on request</p>	<p>Tension spring 101186696 S 900 wire tensioner 101186704 Shackle (stainless steel) 101186490</p>

Dust zone 21, 22

Ordering details



Detailed technical information at:
www.schmersal.com

Safety sensors



The use of magnetic safety sensors is of particular advantage, in cases where extremely dirty conditions can occur. This is provided by the simplicity of cleaning of the devices.

Another advantage is the possibility of concealed mounting behind non-magnetic materials. Working surfaces and storage areas can be designed without dust-collecting edges or other functional cut-outs and structures.

In applications, where a precise approach is not possible and larger tolerances are required, the magnetic safety sensors of the BNS series can also be used.

Content

EX-BNS 250-...-3G/D	92
EX-BNS 33-...-3G/D	94
EX-BNS 120-...-3G/D	96
EX-BNS 180-...-3G/D	98
EX-BNS 303-...-3G/D	100
EX-CSS 180-...-3G/D	102

Safety sensors

EX-BNS 250-...-3G/D

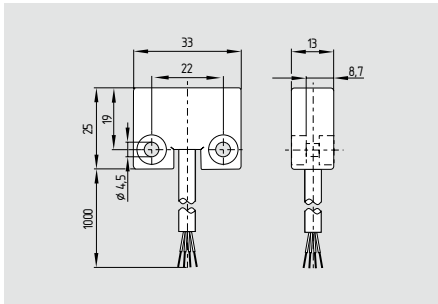

- Ex certified
- Thermoplastic enclosure
- with coding
- Smallest design
- long life, no mechanical wear
- Protection class IP67
- Actuation only possible with EX-BPS 250
- Intensive to transverse misalignment
- Concealed mounting possible
- Intensive to soiling

Technical data

Equipment category: II 3GD
 Explosion protection: Ex nC IIC T6 X
 EX-BNS 250: Ex tD A22 IP67 T80°C X
 EX-BPS 250: c 80°C
 Standards: EN 60947-5-3, EN 61241-0, EN 61241-1, EN 60079-0, EN 60079-15, BG-GS-ET-14
 Design: rectangular
 Enclosure: glass-fibre reinforced thermoplastic
 Max. impact energy: 1 J
 Protection class: IP67 to EN 60529
 Connection: Boflex cable
 Cable section: 4 x 0.25 mm²
 Ordering suffix -2187: 6 x 0.25 mm²
 Operating principle: magnetic
 Actuating magnet: EX-BPS 250, coded
 S_{ao}: 4 mm
 S_{ar}: 14 mm
 Switching condition indication: LED only with ordering suffix G

Max. switching voltage
 without LED: 24 VDC
 with LED: 24 VDC
 Max. switching current
 without LED: 100 mA
 with LED: 10 mA
 Max. switching capacity
 without LED: 1 W
 with LED: 240 mW
 Ambient temperature: -25 °C ... +70 °C
 Storage and transport temperature: -25 °C ... +70 °C
 Max. switching frequency: 5 Hz
 Resistance to shock: 30 g / 11 ms
 Resistance to vibration: 10 ... 55Hz, Amplitude 1 mm

Classification:
 Standards: EN ISO 13849-1
 B_{10d} NC/NO contact: 25.000.000 at 20% contact load
 Service life: 20 years

$$MTTF_d = \frac{B_{10d}}{0,1 \times n_{op}} \quad n_{op} = \frac{d_{op} \times h_{op} \times 3600 \text{ s/h}}{t_{cycle}}$$

Approvals



Ordering details

EX-BNS 250-①z②-③-3G/D

N°	Option	Description
①	11	1 NO / 1 NC contacts
	12	1 NO / 2 NC contacts
②		without LED
	G	with LED
③	2187	Individual contact outlet (only with 1 NO / 2 NC)

Note

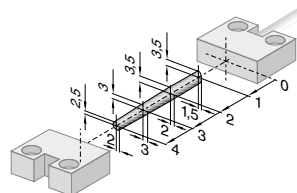

Enabling zone

The actuators for the magnetic safety sensors must be ordered separately.

Contact variants

1 NO / 1 NC contacts

BK 13 14 BU
 WH 21 22 BN

1 NO / 2 NC contacts

BK 22 14 BU
 WH 32 C BN

1 NO / 2 NC

(Ordering suffix -2187 without LED)

GY 13 14 PK
 GN 21 22 YE
 WH 31 32 BN

Note

Contact symbols shown for the closed condition of the guard device.

The contact configuration for versions with or without LED is identical.

The LED is illuminated when the guard door is open.

Safety sensors

System components

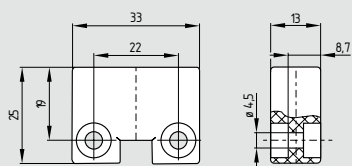

Actuating magnet EX-BPS 250

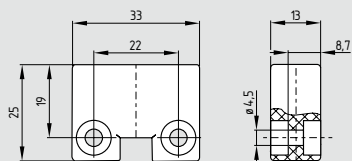

Spacer BNS 250

Ordering details

Actuating magnet
Spacer

EX-BPS 250
BNS 250

Safety sensors

EX-BNS 33-...-3G/D

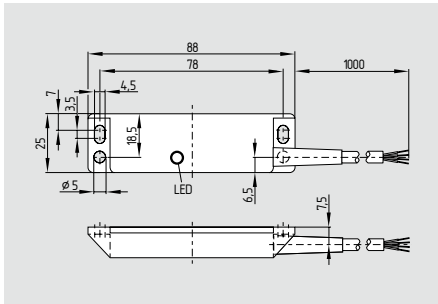

- Ex certified
- Thermoplastic enclosure
- with coding
- long life, no mechanical wear
- Protection class IP67
- Actuation only possible with EX-BPS 33
- Intensive to transverse misalignment
- Concealed mounting possible
- Intensive to soiling

Technical data

Equipment category: II 3GD
 Explosion protection: Ex nC IIC T6 X
 EX-BNS 33: Ex tD A22 IP67 T80°C X
 EX-BPS 33: c 80°C
 Standards: EN 60947-5-3, EN 61241-0, EN 61241-1, EN 60079-0, EN 60079-15, BG-GS-ET-14
 Design: rectangular
 Enclosure: glass-fibre reinforced thermoplastic
 Max. impact energy: 1 J
 Protection class: IP67 to EN 60529
 Connection: Boflex cable
 Cable section: 4 x 0.25 mm²
 Ordering suffix ...-12-2187: 6 x 0.25 mm²
 Operating principle: magnetic
 Actuating magnet: EX-BPS 33, coded
 S_{ao}: 5 mm
 S_{ar}: 15 mm
 Switching condition indication: LED only with ordering suffix G

Max. switching voltage without LED: 100 VAC/DC
 with LED: 24 VDC
 Max. switching current without LED: max. 400 mA
 with LED: 250 mA
 Ordering suffix -2187: 10 mA
 Max. switching capacity without LED: 10 W
 with LED: 3 W
 Ordering suffix ...-2187: 240 mW
 Ambient temperature: -25 °C ... +70 °C
 Storage and transport temperature: -25 °C ... +70 °C
 Repeat accuracy R: ≤ 0.1 x s_{ao}
 Max. switching frequency: ca. 5 Hz
 Resistance to shock: 30 g / 11 ms
 Resistance to vibration: 10 ... 55Hz, Amplitude 1 mm

Classification:

Standards: EN ISO 13849-1
 B_{10d} NC/NO contact: 25.000.000 at 20% contact load
 Service life: 20 years

$$MTTF_d = \frac{B_{10d}}{0,1 \times n_{op}} \quad n_{op} = \frac{d_{op} \times h_{op} \times 3600 \text{ s/h}}{t_{cycle}}$$

Contact variants

1 NO / 1 NC contacts

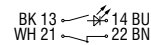

1 NO / 2 NC contacts

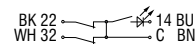

1 NO / 2 NC (Ordering suffix -2187)

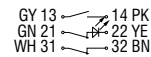

2 NC (Ordering suffix -2187)

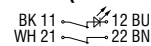

Approvals



Ordering details

EX-BNS 33-①z②-③-3G/D

N°	Option	Description
①	11	1 NO / 1 NC contacts
	12	1 NO / 2 NC contacts
	02	2 NC contacts
②		without LED
	G	with LED
③	2187	Individual contact outlet (not possible for 1 NO/1 NC)

Note

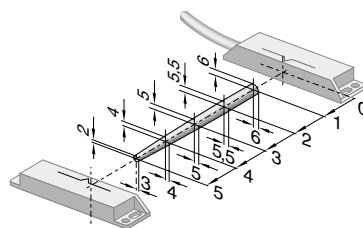

Enabling zone

The actuators for the magnetic safety sensors must be ordered separately.

Note

Contact symbols shown for the closed condition of the guard device.

The contact configuration for versions with or without LED is identical.

Safety sensors

System components

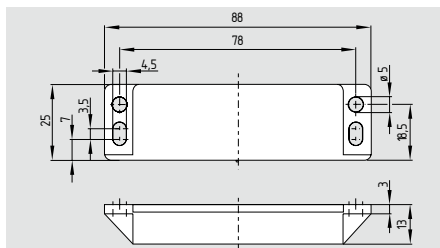

Actuating magnet EX-BPS 33

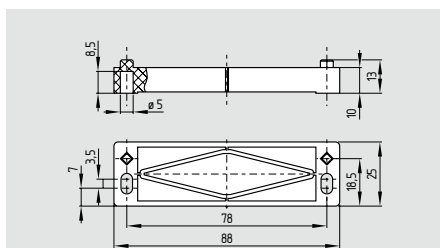

Spacer BN 31/BNS 33

Ordering details

Actuating magnet
Spacer

EX-BPS 33
BN 31/BNS 33

Safety sensors

EX-BNS 120-...-3G/D

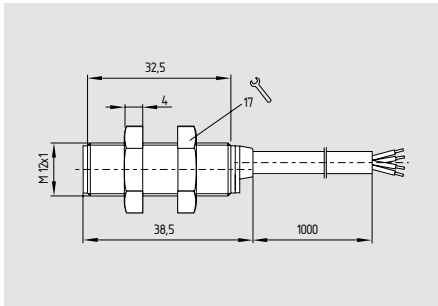

- Ex certified
- Thermoplastic enclosure
- long life, no mechanical wear
- Protection class IP67
- Intensive to transverse misalignment
- Intensive to soiling
- Particularly large switching distance
- Suitable for food processing industry

Technical data

Equipment category: II 3GD
 Ex protection: Ex nC IIC T6 X
 Ex tD A22 IP67 T80°C X

Standards: EN 60947-5-3, EN 61241-0,
 EN 61241-1, EN 60079-0,
 EN 60079-15, BG-GS-ET-14

Design: cylindrical
 Enclosure: glass-fibre reinforced
 thermoplastic, tightening
 torque A/F 17 max. 90 Ncm

Max. impact energy: 1 J
 Protection class: IP67 to EN 60529
 Connection: Boflex cable
 Cable section: 4 x 0.25 mm²
 Operating principle: magnetic
 Actuating magnet: BP 6, BP 8, BP 10,
 BP 15 SS, not coded

S_{ao}: 10 mm (BP 6 / BP 8)
 20 mm (BP 10 / BP 15 SS)
 S_{ar}: 22 mm (BP 6 / BP 8)
 32 mm (BP 10 / BP 15 SS)

Switching condition indication: -
 Switching voltage max. : 100 VAC/DC
 Switching current max. : 250 mA
 Switching capacity max. : 02z: 3 W
 -11z, -12z: 5 W

Ambient temperature: -25 °C ... + 70 °C
 Storage and transport
 temperature: -25 °C ... + 70 °C
 Max. switching frequency: 5 Hz
 Resistance to shock: 30 g / 11 ms
 Resistance to vibration: 10 ... 55Hz,
 Amplitude 1 mm

Classification:

Standards: EN ISO 13849-1
 B_{10d} NC/NO contact: 25.000.000
 at 20% contact load
 Service life: 20 years

$$MTTF_d = \frac{B_{10d}}{0,1 \times n_{op}} \quad n_{op} = \frac{d_{op} \times h_{op} \times 3600 \text{ s/h}}{t_{cycle}}$$

Contact variants

1 NO / 1 NC contacts

BK 13 → 14 BU
 WH 21 → 22 BN

1 NO / 2 NC contacts

BK 22 → 14 BU
 WH 32 → C BN

2 NC contacts

BK 11 → 12 BU
 WH 21 → 22 BN

Approvals



Ordering details

EX-BNS 120-①z-3G/D

N°	Option	Description
①	11	1 NO / 1 NC contacts
	12	1 NO / 2 NC contacts
	02	2 NC contacts

Note

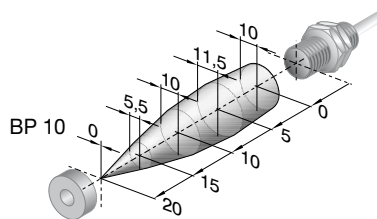

Enabling zone

The actuators for the magnetic safety sensors must be ordered separately.

Note

Contact symbols shown for the closed condition of the guard device.

The safety sensor is to be installed in such a way that operation with a magnet is not possible (covered installation in accordance with EN 1088).

Safety sensors

System components

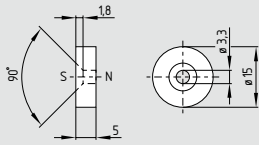

BP 6

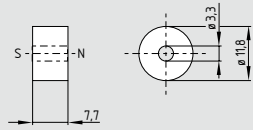

BP 8

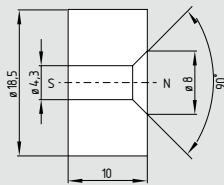

BP 10

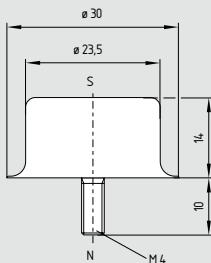

BP 15 SS

Ordering details

Actuating magnets:

- unenclosed **BP 6**
- unenclosed **BP 8**
- unenclosed **BP 10**
- stainless steel **BP 15 SS**

Safety sensors

EX-BNS 180-...-3G/D

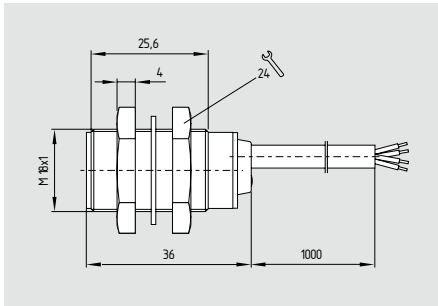

- Ex certified
- Thermoplastic enclosure
- long life, no mechanical wear
- Protection class IP67
- Intensive to transverse misalignment
- Intensive to soiling
- Particularly large switching distance
- Suitable for food processing industry

Technical data

Equipment category: II 3GD
 Ex protection: Ex nC IIC T6 X
 Ex tD A22 IP67 T80°C X

Standards: EN 60947-5-3, EN 61241-0,
 EN 61241-1, EN 60079-0,
 EN 60079-15, BG-GS-ET-14

Design: cylindrical
 Enclosure: glass-fibre reinforced
 thermoplastic, tightening
 torque A/F 24 max. 500 Ncm

Max. impact energy: 1 J
 Protection class: IP67 to EN 60529
 Connection: Boflex cable
 Cable section: 6 x 0.25 mm²
 Operating principle: magnetic
 Actuating magnet: BP 6, BP 8, BP 10,
 BP 15 SS, not coded

S_{ao}: 8 mm (BP 6 / BP 8)
 18 mm (BP 10 / BP 15 SS)
 S_{ar}: 20 mm (BP 6 / BP 8)
 28 mm (BP 10 / BP 15 SS)

Switching voltage max.
 without LED: 120 VAC/DC
 Switching current: max. 250 mA
 Switching capacity: max. 5 W
 Ambient temperature: -25 °C ... +70 °C
 Storage and transport
 temperature: -25 °C ... +70 °C
 Max. switching frequency: 5 Hz
 Resistance to shock: 30 g / 11 ms
 Resistance to vibration: 10 ... 55Hz,
 Amplitude 1 mm

Classification:
 Standards: EN ISO 13849-1
 B_{10d} NC/NO contact: 25.000.000
 at 20% contact load
 Service life: 20 years

$$MTTF_d = \frac{B_{10d}}{0,1 \times n_{op}} \quad n_{op} = \frac{d_{op} \times h_{op} \times 3600 \text{ s/h}}{t_{cycle}}$$

Contact variants

1 NO / 2 NC contacts
 GY 13 → 14 PK
 GN 21 → 22 YE
 WH 31 → 32 BN

Gas zone 2 / Dust zone 22

Approvals



Ordering details

EX-BNS 180-12z-2187-2-3G/D

Note

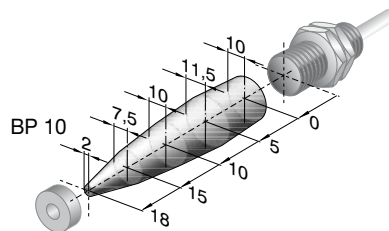

Enabling zone

The actuators for the magnetic safety sensors must be ordered separately.

Note

Contact symbols shown for the closed condition of the guard device.

The safety sensor is to be installed in such a way that operation with a magnet is not possible (covered installation in accordance with EN 1088).

Safety sensors

System components

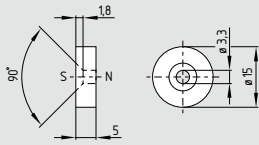

BP 6

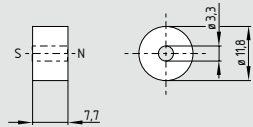

BP 8

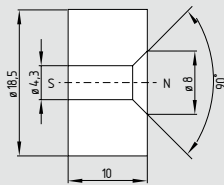

BP 10

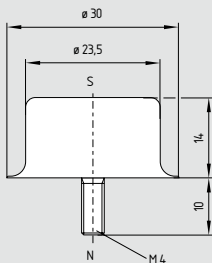

BP 15 SS

Ordering details

Actuating magnets:

- unenclosed **BP 6**
- unenclosed **BP 8**
- unenclosed **BP 10**
- stainless steel **BP 15 SS**

Safety sensors

EX-BNS 303-...-3G/D

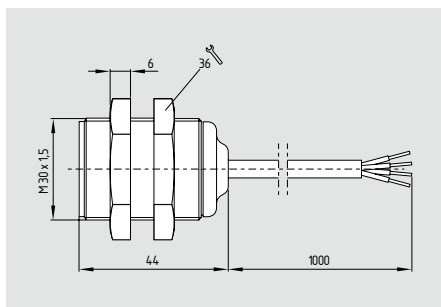
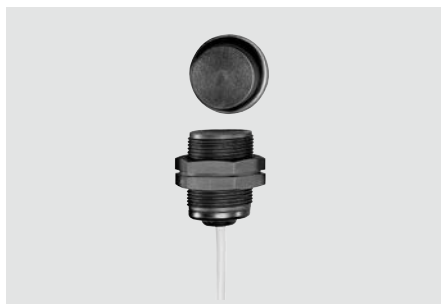

- Ex certified
- Thermoplastic enclosure
- with coding
- long life, no mechanical wear
- Protection class IP67
- Intensive to transverse misalignment
- Intensive to soiling
- Suitable for food processing industry
- LED version available

Technical data

Equipment category: II 3GD
 Ex protection: Ex nC IIC T6 X
 Ex tD A22 IP67 T80°C X
 Standards: EN 60947-5-3, EN 61241-0,
 EN 61241-1, EN 60079-0,
 EN 60079-15, BG-GS-ET-14

Design: cylindrical
 Enclosure: glass-fibre reinforced
 thermoplastic, tightening force
 A/F 36 mm max. 300 Ncm

Max. impact energy: 1 J
 Protection class: IP67 to EN 60529
 Connection: Boflex cable
 Cable section: 6 x 0.25 mm²
 Operating principle: magnetic
 Actuating magnet: BPS 300, BPS 303,
 BPS 303 SS, coded

S_{ao}: 5 mm
 S_{ar}: 15 mm
 Switching condition indication: LED only with
 ordering suffix G

Max. switching voltage
 without LED: max. 100 VAC/DC
 with LED: max. 24 VDC

Max. switching current
 without LED: max. 400 mA
 with LED: 10 mA

Max. switching capacity
 without LED: 10 W
 with LED: 240 mW

Ambient temperature: - 25 °C ... + 70 °C
 Storage and transport
 temperature: - 25 °C ... + 70 °C

Max. switching frequency: 5 Hz
 Resistance to shock: 30 g / 11 ms
 Resistance to vibration: 10 ... 55Hz,
 Amplitude 1 mm

Classification:
 Standards: EN ISO 13849-1
 B_{10d} NC/NO contact: 25.000.000
 at 20% contact load
 Service life: 20 years

$$MTTF_d = \frac{B_{10d}}{0,1 \times n_{op}} \quad n_{op} = \frac{d_{op} \times h_{op} \times 3600 \text{ s/h}}{t_{cycle}}$$

Contact variants

1 NO contacts
2 NC contacts
 GY 13 → 14 PK
 GN 21 → 22 YE
 WH 31 → 32 BN

1 NO contacts
2 NC contacts with LED
 GY 13 → 14 PK
 GN 21 → 22 YE
 WH 31 → 32 BN

Gas zone 2 / Dust zone 22

Approvals



Ordering details

EX-BNS 303-12z①-2187-3G/D

N°	Option	Description
①	G	without LED with LED

Note

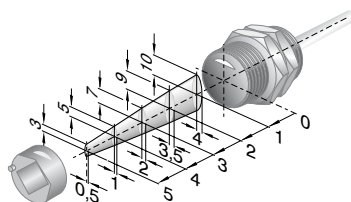

Note

Contact symbols shown for the closed condition of the guard device.

The contact configuration for versions with or without LED is identical.

The LED is illuminated when the guard door is open.

Enabling zone

The actuators for the magnetic safety sensors must be ordered separately.

Safety sensors

System components

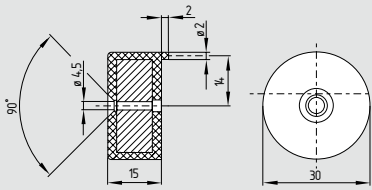

BPS 300

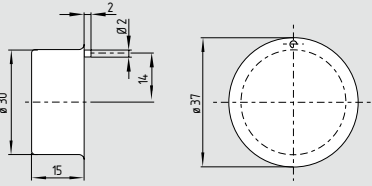

BPS 303

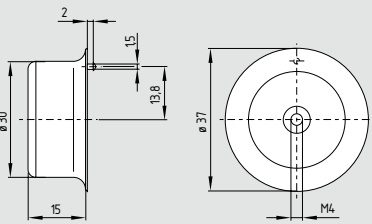

BPS 303 SS

Ordering details

Actuating magnet: with plastic enclosure	BPS 300
with plastic enclosure for food-processing industry	BPS 303
Stainless steel for food-processing industry	BPS 303 SS

Safety sensors

EX-CSS 180-...-3G/D

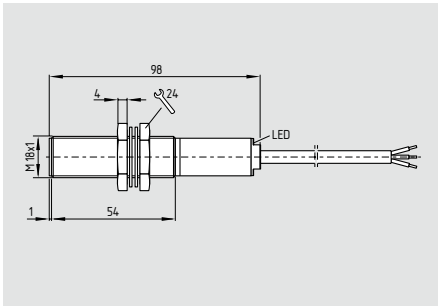

- Ex certified
- Thermoplastic enclosure
- Category 4 to EN 954-1
- Classification PDF-M to EN 60947-5-3
- Fit for SIL 3 applications to IEC 61508, PFH value $< 6.1 \times 10^{-9}$
- Electronic contact-free, coded system
- Large switching distance
- Misaligned actuation possible
- High repeat accuracy of the switching points
- Self-monitored series-wiring of max. 16 sensors
- Max. length of the sensor chain 200 m
- Comfortable diagnostics through sensor LED and electronic signalling output
- Early warning when operating near the limit of the sensor's hysteresis range
- 2 short-circuit proof PNP safety outputs (24 VDC per 500 mA)

Approvals



Ordering details

EX-CSS 8-180-2P+D-M-L-3G/D

Technical data

Equipment category: II 3GD
 Ex protection: Ex nA IIC T6 X
 Ex tD A22 IP67 T70°C X
 Standards: EN 60947-5-3, EN 954-1, IEC 61508, EN 61241-0, EN 61241-1, EN 60079-0, EN 60079-15
 Design: cylindrical
 Enclosure: glass-fibre reinforced thermoplastic
 Max. impact energy: 1 J
 Protection class: IP65 and IP67
 Termination: Cable
 Cable section: $7 \times 0.25 \text{ mm}^2$
 Cable length: max. 200 m
 Operating principle: inductive
 Actuator: CST-180-1, CST-180-2
 Category: 4 to EN 954-1
 Classification: up to PDF-M to IEC 60947-5-3
 SIL classification: suitable for SIL 3 applications to IEC 61508, PFH $< 6.1 \times 10^{-9}$
 Rated switching distance S_{n1} : 8 mm
 S_{ao} : 7 mm
 S_{ar} : 10 mm
 Hysteresis: $\leq 0.7 \text{ mm}$
 Repeat accuracy R: $\leq 0.2 \text{ mm}$
 Response time: $< 30 \text{ ms}$
 Duration of risk: $\leq 30 \text{ ms}$
 U_{e1} : 24 VDC – 15 % / + 10 %
 I_{e1} : 1.0 A
 I_{o1} : 0.05 A
 Leakage current I_r : $\leq 0.5 \text{ mA}$
 Protection class: II
 Overvoltage category: III
 Degree of pollution: 3
 U_{imp} : 0.8 kV
 U_i : 32 VAC/DC
 Safety outputs: short-circuit proof, p-type
 Output current: max. 0.5 A each output
 U_d : max. 0.5 V
 I_e/U_{e1} : 0.5 A / 24 VDC
 Signalling output: short-circuit proof, p-type
 I_e/U_{e1} : 0.05 A / 24 VDC
 Utilisation category: AC-12, DC-13
 Ambient temperature: $-20 \text{ }^\circ\text{C} \dots +40 \text{ }^\circ\text{C}$
 Storage and transport temperature: $-25 \text{ }^\circ\text{C} \dots +85 \text{ }^\circ\text{C}$
 Switching frequency f: ca. 3 Hz
 Resistance to shock: 30 g / 11 ms
 Resistance to vibration: 10 ... 55Hz, Amplitude 1 mm

System components

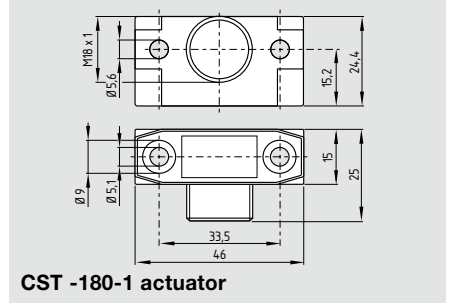

CST -180-1 actuator

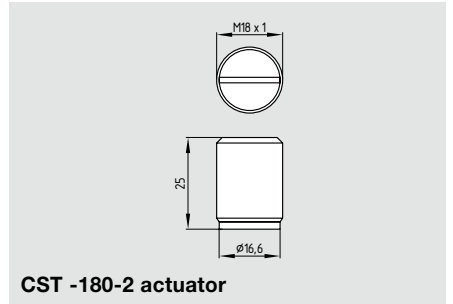

CST -180-2 actuator

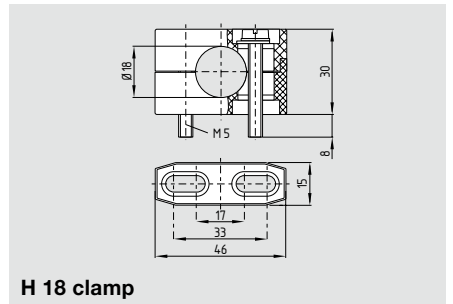

H 18 clamp

Note

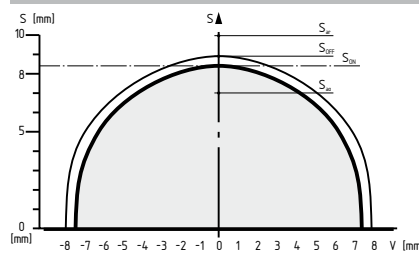

Legend

- S switching distance
- V axial misalignment
- S_{on} switch-on point
- S_{off} switch-off point
- S_h hysteresis range
- S_{ao} assured switch-on point
- S_{ar} Assured release point to EN 60947-5-3

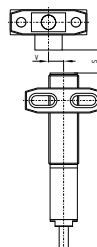

Ordering details

Actuator CST 180-1
 Actuator CST 180-2
 Clamp H 18

Actuators must be ordered separately.

Safety sensors

Connection

Sensor with multifunctional connection:
EX-CSS 8-180-2P+D-M-L-3G/D

Connecting cable:

2 m length;
cable section 7 poles: 7 x 0.25 mm²

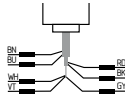

Wiring

Lead colours
Connecting cable

Wiring

BN (brown)	A1 Ue
BU (blue)	A2 GND
VT (violet)	X1 Safety input 1
WH (white)	X2 Safety input 2
BK (black)	Y1 Safety output 1
RD (red)	Y2 Safety output 2
GY (grey)	Signalling output

Safety-monitoring module

Requirements for the safety monitoring module

2-channel p-type safety input. The safety monitoring module must tolerate internal functional tests of the sensors in milliseconds (max. 2 ms).

A range of suitable **safety monitoring modules** for these applications can be found in the „Electronic Safety Sensors and Solenoid Interlocks“ brochure.

Note

- Series-wiring of sensors:
16 self-monitoring CSS 180 safety sensors can be wired in series without loss of control category 4 to EN 954-1. The redundant output of the first sensor is wired into the input of the next sensor.
- The voltage drop over a long sensor chain should be taken into account when planning cable routing. It depends on several factors which are operating voltage, cable length, ambient temperature, number of sensors series connected, and input load of the safety control monitor.

Ordering details



Detailed technical information at:
www.schmersal.com

Magnetic reed switches



Magnetic reed switches are often used to replace mechanically actuated limit switches with plungers, roller and turning levers.

Content
EX-BN 20-...-3G/D

106

Magnetic reed switches

EX-BN 20-...-3G/D

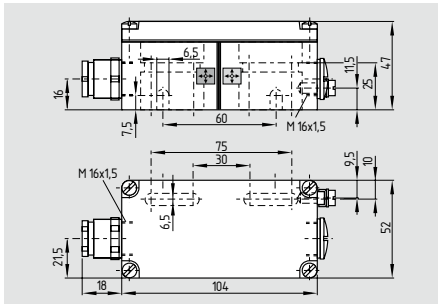

- Ex certified
- Aluminium enclosure
- Long life
- Non-contact principle
- 1 Reed contact
- Particularly resistant to vibration
- Available for actuation from front or side
- Actuating distance up to 50 mm depending on actuating magnet and version
- Screw connection
- Protection class IP67
- 2 cable entries M 16
- Including Ex-certified screwed cable gland

Technical data

Equipment category: II 3GD
 Ex protection: Ex nC IIC T5 X
 Ex tD A22 IP67 T90°C X
 Standards: EN 61241-0, EN 61241-1, EN 60079-0, EN 60079-15
 Enclosure: Al Si12 die-casting, painted
 Max. impact energy: 4 J
 Protection class: IP67 to EN 60529
 Connection: screw terminals
 cable entry: 2x M16
 Operating principle: magnetic
 Switching voltage: max. 250 VAC/DC
 Switching current: max. 3 A
 Switching capacity: max. 120 VA/W
 Dielectric strength: > 600 VAC (50 Hz)
 Switching speed: max. 18 m/s
 Switching frequency: max. 300 S/s
 Switching time
 "Close": 0.3 ms ... 1.5 ms
 "Open": max. 0.5 ms
 Bounce duration: 0.3 ms ... 0.6 ms
 Ambient temperature: -15 °C ... +70 °C
 Storage temperature: -25 °C ... +70 °C
 Mechanical life: 10⁸ operations
 Electrical life: 1 million - 1 billion operations, depending on load
 Resistance to vibration: 50 g on sine wave oscillation
 Switching point accuracy: ± 0.25 mm, T = constant
 Resistance to shock: 30 g / 11 ms
 Resistance to vibration: 10 ... 55 Hz Amplitude 1 mm
 Cable cross-section of the cable glands: min. Ø 6 mm max. Ø 10 mm

Switching distances, refer to next page.

Contact variants

- 1 NO contact EX -BN 20 - 10 z
- 1 NC contact EX - BN 20-01z
- with N -S actuating magnet BP 2

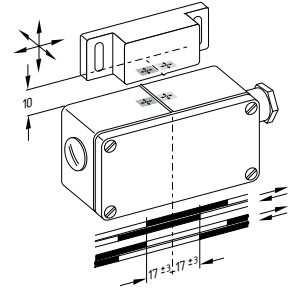

- 1 bistable contact EX-BN 20-rz
- with N actuating magnet BP 20N

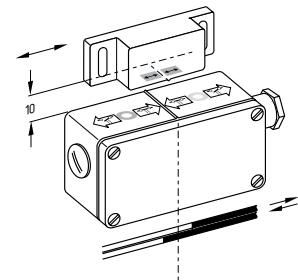

- 1 bistable contact EX-BN 20-rz
- with S actuating magnet BP 20S

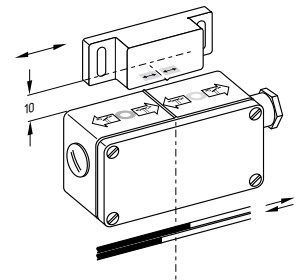

Approvals



Ordering details

EX-BN 20-①Z-3G/D

N°	Insert	Description
①	01	1 NC contacts
	02	2 NC contacts
	10	1 NO contacts
	20	2 NO contacts
	11	1 NC / 1 NO contact
	R	1 bistable contact
	2R	2 bistable contact
	11R	2 bistable contact 1 NC / 1 NO

Note

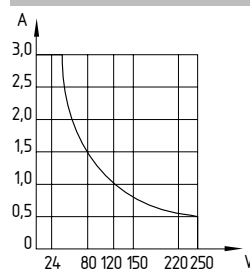

Switching capacity

Note

In version -10 and -01: When the switches and actuators come together, the colours must coincide: Red (S) to red (S) and green (N) to green (N).

The actuators for the magnetic safety sensors must be ordered separately.

On the next pages, a range of suitable actuating magnets is presented.

Magnetic reed switches

Switch distances

Actuating magnet	EX-BN 20-10z EX-BN 20-20z EX-BN 20-01z EX-BN 20-02z EX-BN 20-11z	EX-BN 20-rz EX-BN 20-2rz EX-BN 20-11rz
BP 10 N		5
BP 10 S		5
2 x BP 10	12	
2 x BP 10 N		10
2 x BP 10 S		10
BP 15 N		7
BP 15 S		7
2 x BP 15/2	12	
2 x BP 15/2 N		15
2 x BP 15/2 S		15
BP 34 N		10-25
BP 34 S		10-25
BP 20	15	
BP 20 N		15
BP 20 S		15
BP 31	15	
BP 31 N		15
BP 31 S		15
BP 11	15	
BP 11 N		5
BP 11 S		5
2 x BP 11 N		15
2 x BP 11 S		15
BP 12	25	
BP 12 N		10
BP 12 S		10
2 x BP 12 N		5-20
2 x BP 12 S		5-20
BP 21	20-45	
BP 21 N		10-35
BP 21 S		10-35
2 x BP 21 N		15-50
2 x BP 21 S		15-50

System components

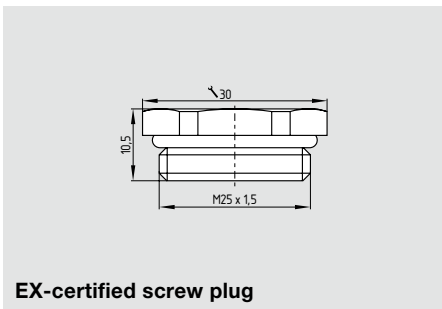
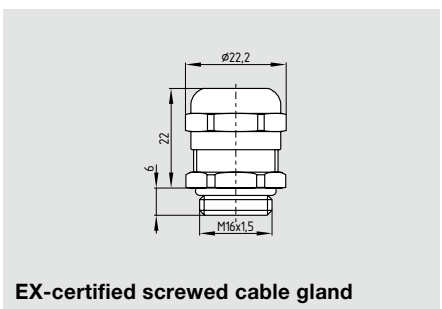

Gas zone 2 / Dust zone 22

Ordering details

EX-certified screwed cable gland	EX-KLE-M16x1.5
EX-certified screw plug	EX-VS-M16x1.5

Magnetic reed switches

System components

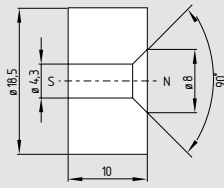

BP 10

System components

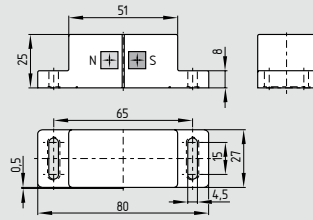

BP 20

System components

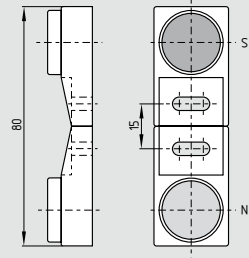

BP 11

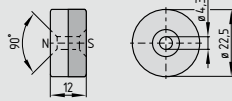

BP 15

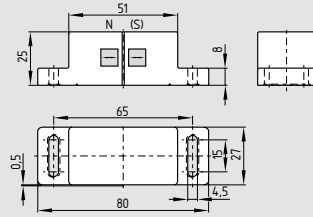

BP 20 N / BP 20 S

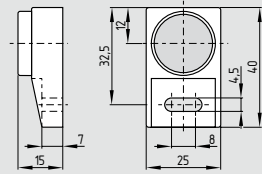

BP 11 N / BP 11 S

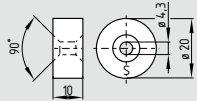

BP 15/2

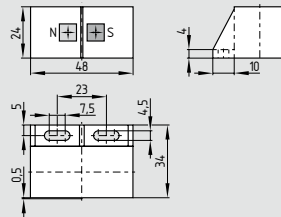

BP 31

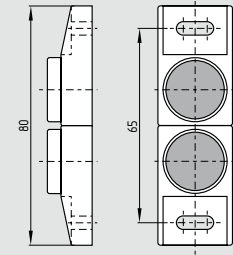

2x BP 11 N / 2x BP 11 S

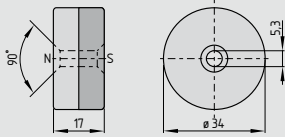

BP 34

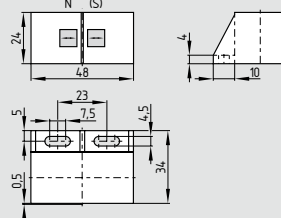

BP 31 N / BP 31 S

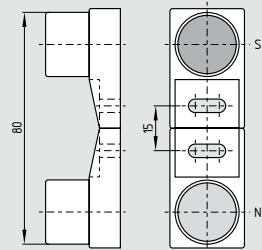

BP 12

Ordering details

Actuating magnet
Unenclosed, N-S
Thermoplastic enclosure, N-S
Unenclosed, N-S
Thermoplastic enclosure, N-S

BP 10
BP 15
BP 15/2
BP 34

Actuating magnet
metal enclosure Al, N-S
metal enclosure Al, N
metal enclosure Al, S
Thermoplastic enclosure, N-S
Thermoplastic enclosure, N-S
Thermoplastic enclosure, N-S

BP 20
BP 20 N
BP 20 S
BP 31
BP 31 N
BP 31 S

Actuating magnet
metal enclosure Al, N-S
metal enclosure Al, N
metal enclosure Al, S
metal enclosure Al, 2x N
metal enclosure Al, 2x S
metal enclosure Al, N-S

BP 11
BP 11 N
BP 11 S
2x BP 11 N
2x BP 11 S
BP 12

Magnetic reed switches

System components

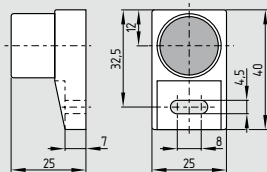

BP 12 N / BP 12 S

System components

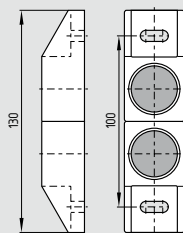

2x BP 21 N / 2x BP 21 S

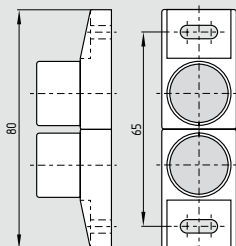

2x BP 12 N / 2x BP 12 S

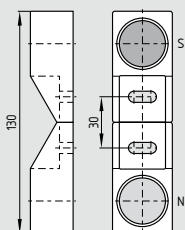

BP 21

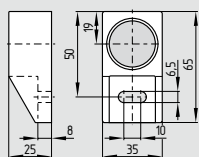

BP 21 N / BP 21 S

Ordering details

Actuating magnet

metal enclosure Al, N
 metal enclosure Al, S
 metal enclosure Al, 2x N
 metal enclosure Al, 2x S
 metal enclosure Al, N-S
 metal enclosure Al, N
 metal enclosure Al, S

BP 12 N
BP 12 S
2x BP 12 N
2x BP 12 S
BP 21
BP 21 N
BP 21 S

Ordering details

Actuating magnet

metal enclosure Al, 2x N
 metal enclosure Al, 2x S

2x BP 21 N
2x BP 21 S

Ordering details

The screenshot displays a web browser window with the URL <http://www.schmersal.net/cat?lang=de&produkt=8ro7329377jbm5d0k440188m5cyp8>. The browser is Windows Internet Explorer. The page content includes:

- Navigation:** Home, Sicherheitszählung, AZM 161, AZM 161CC-12/12RK-024.
- Datenblatt (Data Sheet):**
 -
 - Kunststoffgehäuse
 - schutzisoliert
 - Fehlschließersichere Zählung
 - 130 mm x 90 mm x 30 mm
 - 6 Kontakte
 - hohe Lebensdauer
 - großer Anschlusstraum
 - Hilfsentriegelung
 - 4 Leitungseinführungen M 16 x 1,5
- Bestelldaten (Ordering Data):**

Produkt-Typbezeichnung	AZM 161CC-12/12RK-024
Artikelnummer	1166283
EAN Code	4030661213958
- Zulassung (Certification):** BG, UL, CCC
- Sicherheitsbetrachtung (Safety Considerations):**

Vorschriften	EN ISO 13849-1
Box Öffner (NO)	2 Millionen Schaltspiele
Box Schließer (NO)	1 Million Schaltspiele
Gebrauchsdauer TM	20 Jahre
- Allgemeine Daten (General Data):**

Produkt-Name	AZM 161
Vorschriften	CE/EN 60947-5-1, BG-GS-ET-19
Richtlinienkonformität (LNI)	Ja
Anzahl der Anfahrrichtungen	3 St
Wirkprinzip	elektromechanisch
- Produktarchiv (Product Archive):**
 - Sicheres Schalten und Erfassen
 - Sicherheitsschalter mit getrenntem Betätiger
 - Sicherheitszählung
 - AZM 161**
 - AZM 161CC-12/12RK-024
 - AZM 161CC-12/12RKA-024
 - AZM 161CC-12/12RKT-024
 - AZM 161CC-12/12RKN-024
 - AZM 161CC-12/12K-024
 - AZM 161CC-12/12KA-024
 - AZM 161CC-12/12RKA-110/230
 - AZM 161CC-12/12RKA-110/230
 - AZM 161CC-12/12RKT-110/230
 - AZM 161CC-12/12RKN-110/230
 - AZM 161SK-12/12RK-024
 - AZM 161SK-12/12RKA-110/230
 - AZM 161SK-12/12RKA-024
 - AZM 161SK-12/12RKA-110/230
 - AZM 161SK-12/12RKA-024
 - AZM 161SK-12/12RKA-110/230
 - AZM 161SK-12/12RKAT-024
 - AZM 161SK-12/12RKAT-024
 - Betätiger
 - Türgriff System STS
 - AZM 170
 - AZM 170i
 - AZM 190
 - AZM 415
 - Positionsschalter
 - Sicherheitsschalter für drehbare Schutzeinrichtungen
 - Sicherheits-Sensoren
 - Selbst-Notsschalter
 - NOT-HALT-Taster
 - Sicherheitsgerichteter Laserscanner
 - Sicherheits-Lichtschranken
 - Sicherheits-Lichtvorhänge, Sicherheits-Lichtgitter
 - Zweihandbedienpulte
 - Türgriffschalter
 - Zustimmungsschalter
 - Sicherheitsgerichteter taktiler Sensor
 - Fußschalter
 - AS-Interface Safety at Work

Detailed technical information at:
www.schmersal.com

Control devices and indicator lights



The entire EX-R programme has a modular structure. Each control device \and allows a great diversity of variants: various versions of push-buttons and illuminated buttons, indicator lights, emergency-stop buttons, selector switches and key-operated selector switches are available.

Content	
EX-RDT...	114
EX-RDM...	114
EX-RDL...	115
EX-RDLM...	115
EX-RMLH...	116
EX-RDP40...	117
EX-RDRZ45...	118
EX-RDRZ45rt	119
EX-RW...21/32	120
EX-RW...21.1/32.1	120
EX-RS...	122
EX-RF 10...	124
EX-RF 03...	124
EX-RLDE ws 24	125
EX-EBG 311.O	126
EX-EBG 633.O	126
EX-EBG 665.O	126

Control devices and indicator lights

General description

Concept

With the development of the new programme of 22 mm Ex control devices and indicator lights, Elan provides the user with a state-of-the-art switchgear concept that is compliant to EN 61241 and EN 60 079, featuring additional device functionality, reliability and spatial use beyond the usual standard. The EX-RF/RLDE contact and light element system makes a special contribution here. Well-trying and proven features and material from earlier Elan designs (metal front parts, caps in high-quality shock-proof thermoplastic) have been retained and improved.

The equipment is suitable for the Ex category II 2GD. The explosion protection or the type of protection of the devices is:

- Ex ib IIC T4 X
- Ex tD A21 IP65 T110°C X

Control devices and indicator light heads

A large diversity of fully insulated pushbuttons/ impact buttons/illuminated buttons/pivoting pushbuttons etc. is offered. The front part of the actuating head is in chrome-plated brass. The programme is characterised by large actuating surfaces of at least 28 mm. The material of the button is brass-coated. The caps or lens covers of the illuminated pushbuttons and indicator lights are in shock-proof thermoplastic. In addition to the high mechanical strength, this material selection permits a more than average degree of resistance to heat and chemical effects.

Protection class

The front seal of these devices corresponds to protection class IP65 to EN DIN 60 529. The design features of the device sealing guarantee the maximum of protection over a long period of time, even in extreme conditions.

Mechanical protection

Mechanical tests are carried out in accordance with EN 60079-0. The enclosures or the exterior part of the enclosure, pushbuttons must withstand a high impact energy.

Programme structure

A control and indicator device consists of an actuator, a mounting flange and a contact or light element. The type designation of this type series starts with EX-R..., e. g. EX-RDT for a pushbutton. The mounting flange (divided into two, type EX-RLM) is included in the delivery of the device heads, both for the operating and the display elements.

Per control device, a maximum of 2 contact elements is provided.

One-hole fixing

The devices are designed for mounting holes of 22.3 mm + 0.4 mm according to DIN EN 60 947-5-1 Pt. 6.3.1. An additional cut-out to prevent rotation is not required.

Spacing

It is possible to install several devices with minimum dimensions in the following way:

Minimum distance between the mounting holes to DIN EN 60 947-5-1:

- horizontal: 40 mm
- vertical: 50 mm

Exceptions:

Selector switches/pushbuttons with long knob, emergency stop buttons EX-RDRZ45...:

- horizontal: 50 mm
- vertical: 60 mm

Mechanical protection to EN 60 079-0

Risk of mechanical hazard	High		Low	
	I	II	I	II
Enclosure and external accessible parts of the enclosure	20 Nm	7 Nm	7 Nm	4 Nm
Translucent parts without safety guard	7 Nm	4 Nm	4 Nm	2 Nm
	No further protective measures required		Mechanical protected fitting	

Control devices and indicator lights

Assembly schematic

Pushbutton

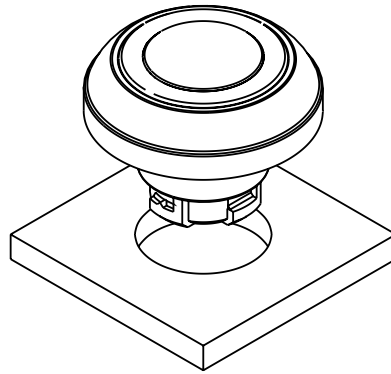

Fixing flange

Mounting flange

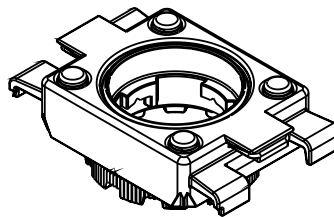

Contact carrier with contact lugs and 2 plunger elements

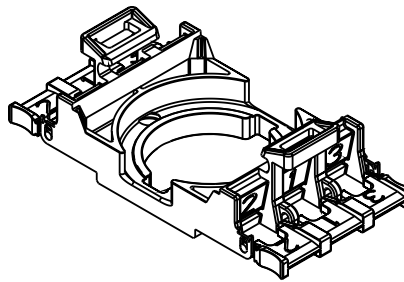

Light element with integrated multi-LED

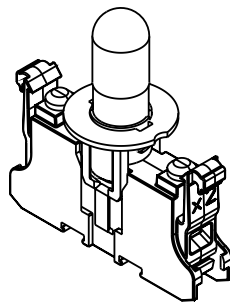

Contact elements

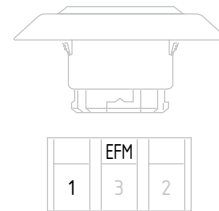
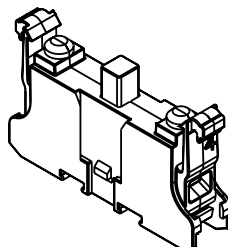

Control devices and indicator lights – Pushbuttons

EX-RDT...

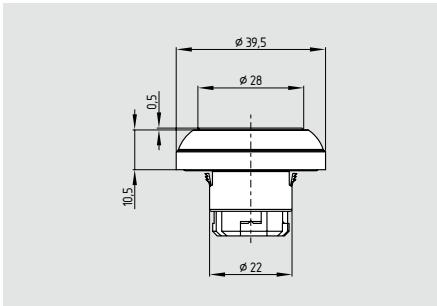

• Pushbutton

EX-RDM...

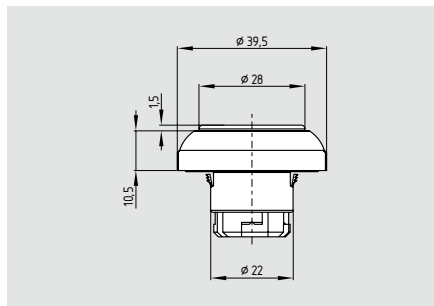

• Pushbutton with membrane

Technical data

Equipment category:	Ⓔ II 2GD
Ex protection:	Ex ib IIC T4 X
Standards:	Ex tD A21 IP65 T110°C X EN 60947-5-1, EN 60947-1, EN 61241-0, EN 61241-1, EN 60079-0, EN 60079-11
Max. impact energy (EN 60079-0):	7 J
Design:	round
Installation-ø:	22.3 mm
Grid dimensions:	40 × 50 mm
Front plate thickness:	1 ... 6 mm
Mounting position:	random
Designation:	identification plates, symbols
Climatic resistance to DIN EN 60068:	Part 2-30
Ambient temperature:	-20 °C ... + 55 °C
Switching frequency:	1,000 s/h
Protection class to EN 60529:	IP65
Full insulation:	yes
Materials:	
Membranes:	PC (good resistance to chemical agents)
Front ring/buttons:	chrome-plated brass, powder-coated brass with mounting flange
Fixing:	
Max. tightening torque:	2 Nm
Resistance to shocks to EN 60068-2-27:	< 50 g
Resistance to vibrations to EN 60068-2-6:	5 g
Actuating stroke:	4 mm
Actuating force:	without membrane approx. 1.5 N with membrane approx. 2 N
Mechanical life:	1 × 10 ⁶ operations
Rohs conformity:	yes

Approvals



Ordering details

Ex-RDT ① ②

N°	Option	Description
①	bk	black
	ye	yellow
	rd	red
	gn	green
	wh	white
	bu	blue
②	Identification plate, symbols: refer to page 128	

Approvals



Ordering details

Ex-RDM ① ②

N°	Option	Description
①	bk	black
	ye	yellow
	rd	red
	gn	green
	wh	white
	bu	blue
②	Identification plate, symbols: refer to page 128	

Note

The EX-RLM fixing flange, consisting of mounting flange, contact carrier with contact lugs and 2 plunger elements, is not included in the delivery of the device heads (refer to page 127)

Control devices and indicator lights – Illuminated pushbuttons

EX-RDL...

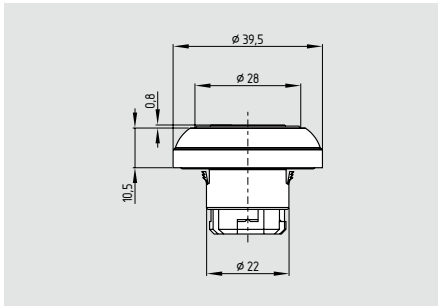

• Illuminated pushbutton

EX-RDLM...

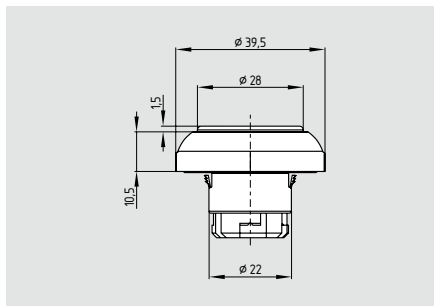

• Illuminated pushbutton with membrane

Technical data

Equipment category:	Ⓔ II 2GD
Ex protection:	Ex ib IIC T4 X
Standards:	Ex tD A21 IP65 T110°C X EN 60947-5-1, EN 60947-1, EN 61241-0, EN 61241-1, EN 60079-0, EN 60079-11
Max. impact energy:	4 J
Design:	round
Installation-ø:	22.3 mm
Grid dimensions:	40 × 50 mm
Front plate thickness:	1 ... 6 mm
Mounting position:	random
Designation:	identification plates, symbols
Climatic resistance to DIN EN 60068:	Part 2-30
Ambient temperature:	-20 °C ... + 55 °C
Switching frequency:	1,000 s/h
Protection class to EN 60529:	IP65
Full insulation:	yes
Materials:	
Membranes:	PC (good resistance to chemical agents)
Front ring/buttons:	chrome-plated brass, powder-coated brass with mounting flange
Fixing:	
Max. tightening torque:	2 Nm
Resistance to shocks to EN 60068-2-27:	< 50 g
Resistance to vibrations to EN 60068-2-6:	5 g
Actuating stroke:	4 mm
Actuating force:	ca. 1.5 N
Mechanical life:	1 × 10 ⁶ operations
Rohs conformity:	yes

Approvals



Approvals



Ordering details

Ex-RDL ① ②

N°	Option	Description
①	bk	black
	ye	yellow
	rd	red
	gn	green
	wh	white
	bu	blue
②	Identification plate, symbols: refer to page 128	

Ordering details

Ex-RDLM ① ②

N°	Option	Description
①	bk	black
	ye	yellow
	rd	red
	gn	green
	wh	white
	bu	blue
②	Identification plate, symbols: refer to page 128	

Note

The EX-RLM fixing flange, consisting of mounting flange, contact carrier with contact lugs and 2 plunger elements, is not included in the delivery of the device heads (refer to page 127)

Control devices and indicator lights – Indicator lights

EX-RMLH...

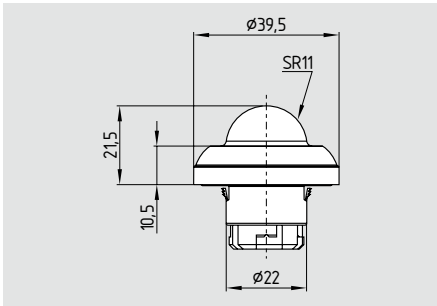

• Indicator light with domed cap

Technical data

Equipment category:	⊕ II 2GD
Ex protection:	Ex ib IIC T4 X
	Ex tD A21 IP65 T110°C X
Standards:	EN 60947-5-1, EN 60947-1, EN 61241-0, EN 61241-1, EN 60079-0, EN 60079-11
Max. impact energy:	4 J
Design:	round
Installation-ø:	22.3 mm
Grid dimensions:	40 x 50 mm
Front plate thickness:	1 ... 6 mm
Mounting position:	random
Designation:	identification plates, symbols
Climatic resistance to DIN EN 60068:	Part 2-30
Ambient temperature:	-20 °C ... + 55 °C
Protection class to EN 60529:	IP65
Full insulation	yes
Materials:	
Lens covers	PC (good resistance to chemical agents)
Front ring/buttons:	chrome-plated brass, powder-coated brass with mounting flange
Fixing:	
Max. tightening torque:	2 Nm
Resistance to shocks to EN 60068-2-27:	< 50 g
Resistance to vibrations to EN 60068-2-6:	5 g
Rohs conformity:	yes

Approvals



Ordering details

Ex-RMLH ① ②

N°	Option	Description
①	ye	yellow
	rd	red
	gn	green
	wh	white
	bu	blue
②	Identification plate, symbols: refer to page 128	

Note

The EX-RLM fixing flange, consisting of mounting flange, contact carrier with contact lugs and 2 plunger elements, is not included in the delivery of the device heads (refer to page 127)

Control devices and indicator lights – Mushroom buttons

EX-RDP40...

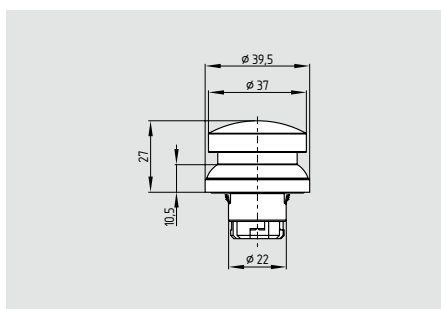

• Mushroom button without latching function

Technical data

Equipment category: Ⓜ II 2GD
 Ex protection: Ex ib IIC T4 X
 Ex tD A21 IP65 T110°C X
 Standards: EN 60947-5-1, EN 60947-1,
 EN 61241-0, EN 61241-1,
 EN 60079-0, EN 60079-11
 Max. impact energy: 4 J
 Design: round
 Installation-ø: 22.3 mm
 Grid dimensions: 50 x 60 mm
 Front plate thickness: 1 ... 6 mm
 Mounting position: random
 Designation: identification plates, symbols
 Climatic resistance
 to DIN EN 60068: Part 2-30
 Ambient temperature: -20 °C ... + 55 °C
 Switching frequency: 1,000 s/h
 Protection class to EN 60529: IP65
 Full insulation: yes
 Materials:
 Front ring/buttons: chrome-plated brass,
 powder-coated brass
 with mounting flange
 Fixing:
 Max. tightening torque: 2 Nm
 Resistance to shocks to EN 60068-2-27: < 50 g
 Resistance to vibrations to EN 60068-2-6: 5 g
 Actuating stroke: 4 mm
 Actuating force: approx. 2 N
 Mechanical life: 1 x 10⁶ operations
 Rohs conformity: yes

Approvals



Ordering details

Ex-RDP40 ① ②

N°	Option	Description
①	bk	black
	ye	yellow
	rd	red
	gn	green
	wh	white
	bu	blue
②	Identification plate, symbols: refer to page 128	

Note

The EX-RLM fixing flange, consisting of mounting flange, contact carrier with contact lugs and 2 plunger elements, is not included in the delivery of the device heads (refer to page 127)

Control devices and indicator lights – Mushroom buttons

EX-RDRZ45...

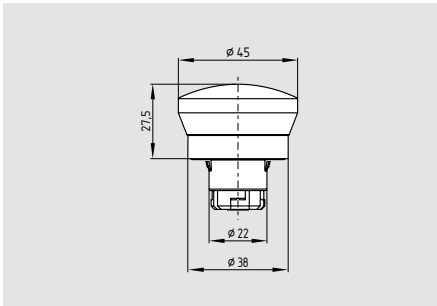

- Mushroom button with latching function

Technical data

Equipment category:	Ⓔ II 2GD
Ex protection:	Ex ib IIC T4 X
	Ex tD A21 IP65 T110°C X
Standards:	EN 60947-5-1, EN 60947-1, EN 61241-0, EN 61241-1, EN 60079-0, EN 60079-11
Max. impact energy:	4 J
Design:	round
Installation-ø:	22.3 mm
Grid dimensions:	50 × 60 mm
Front plate thickness:	1 ... 6 mm
Mounting position:	random
Climatic resistance to DIN EN 60068:	Part 2-30
Ambient temperature:	-20 °C ... + 55 °C
Switching frequency:	600 s/h
Protection class to EN 60529:	IP65
Full insulation	yes
Materials:	
Front ring/buttons:	chrome-plated brass, powder-coated brass with mounting flange
Fixing:	
Max. tightening torque:	2 Nm
Resistance to shocks to EN 60068-2-27:	< 50 g
Resistance to vibrations to EN 60068-2-6:	5 g
Actuating stroke:	5 mm
Actuating force:	approx. 2 N
Mechanical life:	1 × 10 ⁵ operations
Rohs conformity:	yes

Approvals



Ordering details

Ex-RDRZ45 ① ②

N°	Option	Description
①	bk ye gn	black yellow green
②	Identification plate, symbols: refer to page 128	

Note

The EX-RLM fixing flange, consisting of mounting flange, contact carrier with contact lugs and 2 plunger elements, is not included in the delivery of the device heads (refer to page 127)

Control devices and indicator lights – Emergency stop buttons

EX-RDRZ45rt

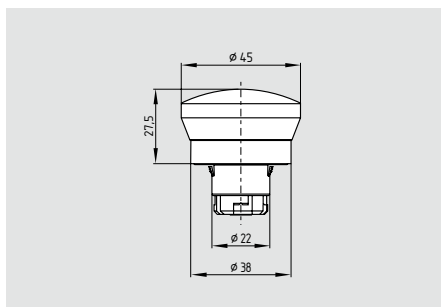

- Emergency stop button to ISO 13850, 2006

Technical data

Equipment category:	⊕ II 2GD
Ex protection:	Ex ib IIC T4 X
	Ex tD A21 IP65 T110°C X
Standards:	EN 60947-5-1; EN 60947-5-5
	EN 60947-1; EN 61241-1
	EN 60079-0; EN 60079-11
Max. impact energy:	4 J
Design:	round
Installation-ø:	22.3 mm
Grid dimensions:	50 × 60 mm
Front plate thickness:	1 ... 6 mm
Mounting position:	random
Climatic resistance to DIN EN 60068:	Part 2-30
Ambient temperature:	-20 °C ... + 55 °C
Switching frequency:	600 s/h
Protection class to EN 60529:	IP65
Full insulation:	yes
Materials:	
Front ring/buttons:	chrome-plated brass, powder-coated brass with mounting flange
Fixing:	
Max. tightening torque:	2 Nm
Resistance to shocks to EN 60068-2-27:	< 50 g
Resistance to vibrations to EN 60068-2-6:	5 g
Actuating stroke:	5 mm
Actuating force:	approx. 2 N
Mechanical life:	1 × 10 ⁵ operations
Rohs conformity:	yes

Approvals



Ordering details

Ex-RDRZ45 rt

Note

The EX-RLM fixing flange, consisting of mounting flange, contact carrier with contact lugs and 2 plunger elements, is not included in the delivery of the device heads (refer to page127)

Control devices and indicator lights

EX-RW...21/32

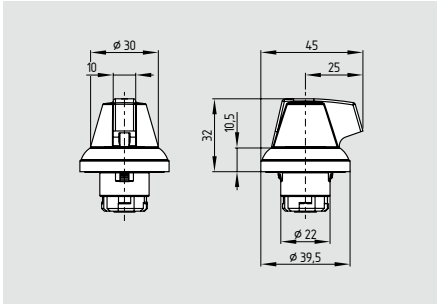

- Maintained selector switch, spring return selector switch with short knob
- 2 or 3 positions

EX-RW...21.1/32.1

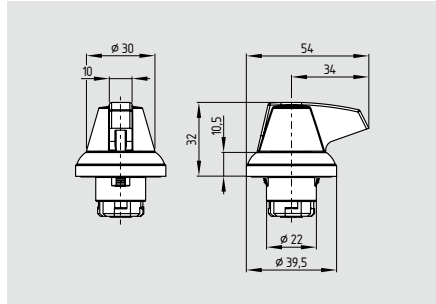

- Maintained selector switch, spring return selector switch with long knob
- 2 or 3 positions

Technical data

Equipment category:	Ⓜ II 2GD
Ex protection:	Ex ib IIC T4 X
Standards:	Ex tD A21 IP65 T110°C X EN 60947-5-1, EN 60947-1, EN 61241-0, EN 61241-1, EN 60079-0, EN 60079-11
Max. impact energy:	4 J
Design:	round
Installation-ø:	22.3 mm
Grid dimensions:	50 × 60 mm
Front plate thickness:	1 ... 6 mm
Mounting position:	random
Designation:	identification plates, symbols
Climatic resistance to DIN EN 60068:	Part 2-30
Ambient temperature:	0 °C ... + 55 °C
Switching frequency:	1,000 s/h
Protection class to EN 60529:	IP65
Full insulation:	yes
Materials:	
Knob:	PC (good resistance to chemical agents)
Front ring/buttons:	chrome-plated brass, powder-coated brass with mounting flange
Fixing:	
Max. tightening torque:	2 Nm
Resistance to shocks to EN 60068-2-27:	< 50 g
Resistance to vibrations to EN 60068-2-6:	5 g
Actuating stroke:	6 mm
Actuating force:	approx. 0.2 N
Mechanical life:	3 × 10 ⁵ operations
Rohs conformity:	yes

Approvals



Approvals



Ordering details

Ex-RW^① ②

N°	Option	Description
①	T	Selector switch
	S	Selector switch
	ST	Spring-return rotary selector switch
	TS	Maintained spring-return rotary selector switch
②	21	2 positions
	32	3 positions

Ordering details

Ex-RW^① ②.1

N°	Option	Description
①	T	Selector switch
	S	Selector switch
	ST	Spring-return rotary selector switch
	TS	Maintained spring-return rotary selector switch
②	21	2 positions
	32	3 positions

Note

The EX-RLM fixing flange, consisting of mounting flange, contact carrier with contact lugs and 2 plunger elements, is not included in the delivery of the device heads (refer to page 127)

Control devices and indicator lights

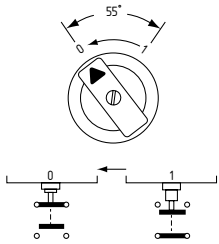
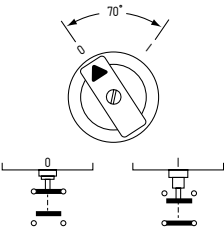
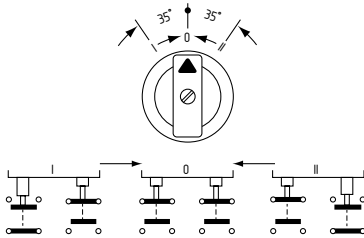
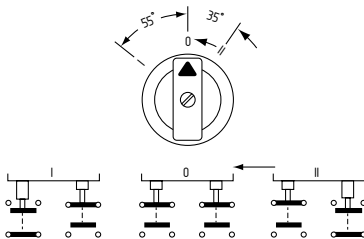
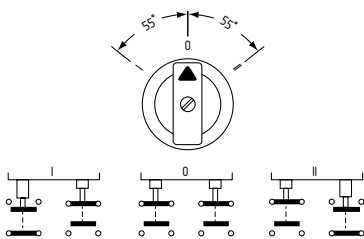
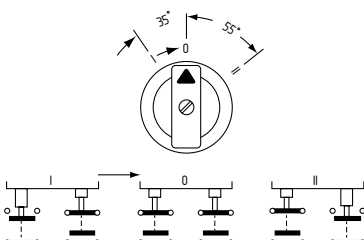
Brief description	Switching angle		Type
Spring-return rotary selector switch with 2 positions	1 × 55°		Ex-RWT 21 Ex-RWT 21.1
Selector switch with 2 latched positions	1 × 70°		Ex-RWS 21 Ex-RWS 21.1
Maintained spring-return rotary selector switch with 3 positions	2 × 35°		Ex-RWT 32 Ex-RWT 32.1
Selector switch with 3 positions; right: latching, left: switching	right 35° left 55°		Ex-RWST 32 Ex-RWST 32.1
Maintained spring-return rotary selector switch with 3 positions	2 × 55°		Ex-RWS 32 Ex-RWS 32.1
Maintained spring-return rotary selector switch with 3 positions, right: switching, left: latching	right 55° left 35°		Ex-RWTS 32 Ex-RWTS 32.1

Control devices and indicator lights

EX-RS...

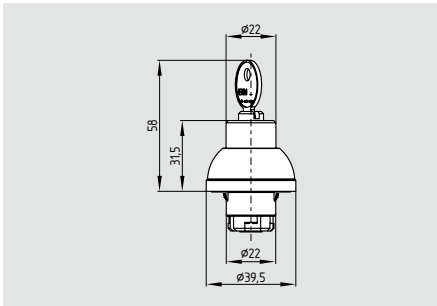

- Key-operated selector switch
- 1, 2 or 3 positions

Technical data

Equipment category:	Ⓔ II 2GD
Ex protection:	Ex ib IIC T4 X
	Ex tD A21 IP65 T110°C X
Standards:	EN 60947-5-1, EN 60947-1, EN 61241-0, EN 61241-1, EN 60079-0, EN 60079-11
Max. impact energy:	4 J
Design:	round
Installation-ø:	22.3 mm
Grid dimensions:	40 x 50 mm
Front plate thickness:	1 ... 6 mm
Mounting position:	random
Designation:	identification plates, symbols
Climatic resistance to DIN EN 60068:	Part 2-30
Ambient temperature:	0 °C ... + 55 °C
Switching frequency:	1,000 s/h
Protection class to EN 60529:	IP65
Full insulation:	yes
Materials:	
Front ring/buttons:	chrome-plated brass, powder-coated brass with mounting flange
Fixing:	
Max. tightening torque:	2 Nm
Resistance to shocks to EN 60068-2-27:	< 50 g
Resistance to vibrations to EN 60068-2-6:	5 g
Actuating stroke:	6 mm
Actuating force:	approx. 0.2 N
Mechanical life:	1 x 10 ⁵ operations
Rohs conformity:	yes

Approvals



Ordering details

Ex-RS^{①②③④}

N°	Option	Description
①	S	Key-operated selector switch
	ST	Key-operated spring-return selector switch
②	2	position of the key
	3	
③	2	number of plungers
	3	
④	1	position for key retraction
	2	
	3	

Note

The EX-RLM fixing flange, consisting of mounting flange, contact carrier with contact lugs and 2 plunger elements, is not included in the delivery of the device heads (refer to page 127)

Control devices and indicator lights

Key-operated selector switches/selector switch pushbuttons, lock EKM 30

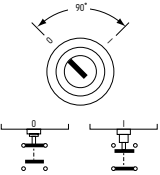
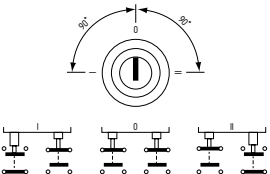
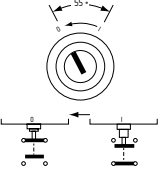
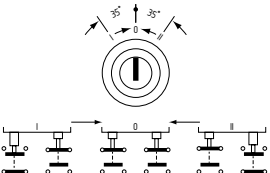
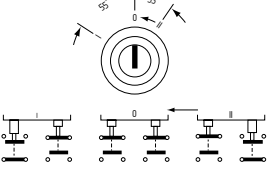
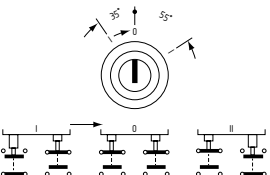
Brief description		Key-withdrawal position	Type
Key-operated selector switch with 2 latched positions		only left only right in both positions	Ex-RSS21S1 Ex-RSS21S2 Ex-RSS21S12
Key-operated selector switch with 3 latched positions		left middle right in all 3 positions	Ex-RSS32S1 Ex-RSS32S2 Ex-RSS32S3 Ex-RSS32S123
Key-operated spring-return selector switch with 1 touch position, automatic return to the zero position, latch position 55°		only left	Ex-RST21S1
Key-operated spring-return selector switch with 2 touch positions left and right, automatic return to the zero position		only middle	Ex-RST32S2
Key-operated selector switch pushbutton with 3 positions, touch position 35°, latch position 55° – left switching, right latching		S1 = only left S2 = only middle	Ex-RSST32S1 Ex-RSST32S2
Key-operated selector switch pushbutton with 3 positions, touch position 35°, latch position 55° – left switching, right latching		S2 = only middle S3 = only right	Ex-RSTS32S2 Ex-RSTS32S3
Spare key EKM 30 for CES lock (for EX-RSS../RST.., standard for the above listed versions)			SDS2

Special locks and master key function available: On request

Contact elements: See page 124

2 keys belong to the delivery range of the above listed devices

Control devices and indicator lights – Contacts

EX-RF 10...

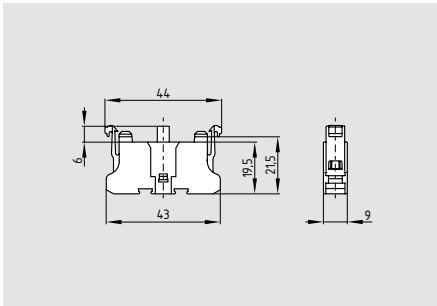

- NC
- Screw connection
- Cable sections
 - single-strand $2 \times (0.5 \dots 2.5 \text{ mm}^2)$
 - multi-strand with conductor ferrules $2 \times (0.5 \dots 1.5 \text{ mm}^2)$
- Protection class
 - Connections: IP20 (finger-safe)
 - Wiring compartments: IP40

EX-RF 03...

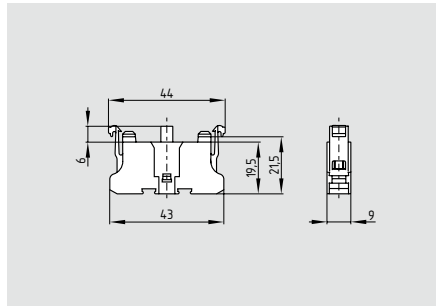

- NO contacts
- Screw connection
- Cable sections
 - single-strand $2 \times (0.5 \dots 2.5 \text{ mm}^2)$
 - multi-strand with conductor ferrules $2 \times (0.5 \dots 1.5 \text{ mm}^2)$
- Protection class
 - Connections: IP20 (finger-safe)
 - Wiring compartments: IP40

Technical data

Equipment category:	Ⓔ II 2GD
Explosion protection:	Ex ib IIC T4 X
Standards:	Ex tD A21 IP65 T110°C X EN 60947-5-1, EN 61241-0, EN 61241-1, EN 60079-11
U_i :	250 V
I_i :	3.3 A for Ex ib 5.0 A at Ex ic
C_i :	~ 0
L_i :	~ 0
U:	250 V
I:	5 A
P:	max. 1500 W
Contact reliability:	5 VDC/1 mA
Proof of positive opening:	2.5 kV impulse voltage
Positive opening path:	approx. 2 mm after achieving opening point
Air clearance and creepage distance to DIN EN 60 664-1:	4 kV/3
Switching frequency:	1.200 s/h
Switching points:	
NC contact:	approx. 1 mm
NO contact:	approx. 2.5 mm
Temperature range:	-20° C ... + 55° C
Climate resistance to DIN EN 60068:	Part 2-20
Mounting position:	random
Mechanical life to EN 60 947-5-1:	10×10^6 operations
Actuating force at stroke end:	approx. 4.5 N
Terminal designations:	to EN 60947-1
Tightening torque for the connecting screw:	max. 1 Nm

Approvals



Ordering details

Ex-RF ①

N°	Option	Description
①	10	Contact labelling 1, 2
	10.1	Contact labelling 11, 12

Approvals



Ordering details

Ex-RF ①

N°	Option	Description
①	03	Contact labelling 3, 4
	03.1	Contact labelling 13, 14

Control devices and indicator lights – Light terminal blocks

EX-RLDE ws 24

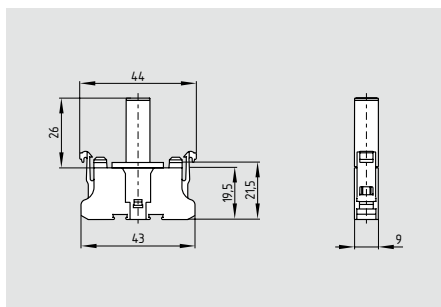

- Light terminal block
- Screw connection
- Cable sections
 - single-strand $2 \times (0.5 \dots 2.5 \text{ mm}^2)$
 - multi-strand with conductor ferrules $2 \times (0.5 \dots 1.5 \text{ mm}^2)$
- Protection class
 - Connections: IP20 (finger-safe)
 - Wiring compartments: IP40

Technical data

Equipment category: II 2GD
 Explosion protection: Ex ib IIC T4 X
 $\text{Ex tD A21 IP65 T110}^\circ\text{C X}$
 Standards: EN 60947-5-1, EN 61241-0,
 EN 61241-1, EN 60079-11
 U_i : 30 V
 I_i : not relevant (max. 30 mA)
 P_i : not relevant (max. 30 mA)
 C_i : ~ 0
 L_i : ~ 0
 U : 24 V +/-10%
 I : 30 mA
 P : 0.9 W
 Temperature range: $-20^\circ\text{C} \dots +55^\circ\text{C}$
 Climate resistance to
 DIN EN 60068: Part 2-20
 Mounting position: random
 Terminal designations: to EN 60947-1
 Tightening torque
 for the connecting screw: max. 1 Nm

Approvals



Ordering details

Ex-RLDE ws 24

Control devices and indicator lights – Enclosure

Gas zone 1, 2 / Dust zone 21, 22

EX-EBG 311.O

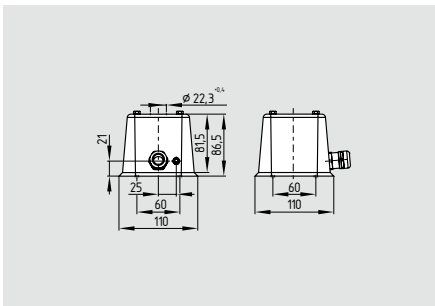

- Empty enclosure in V4A
- Version with 1 fitting hole for installation \varnothing 22.3 mm
- incl. 1 cable gland M20

EX-EBG 633.O

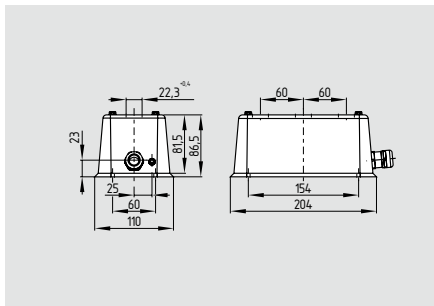

- Empty enclosure in V4A
- Version with 3 fitting holes for installation \varnothing 22.3 mm
- incl. 1 cable gland M25

EX-EBG 665.O

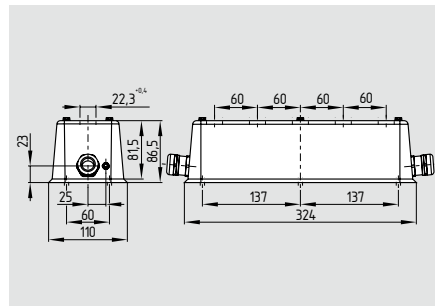

- Empty enclosure in V4A
- Versions with 5 fitting holes for installation \varnothing 22.3 mm
- incl. 2 cable glands M25
- incl. 1 locking screw

Approvals



Approvals



Approvals



Ordering details

EX-EBG 311.O

Ordering details

EX-EBG 633.O

Ordering details

EX-EBG 665.O

Control devices and indicator lights – Accessories

System components



System components

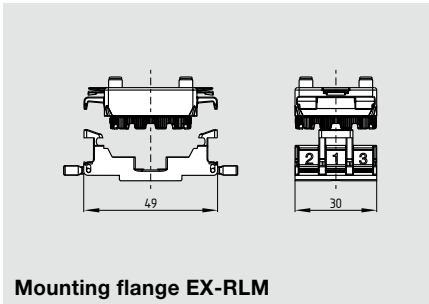
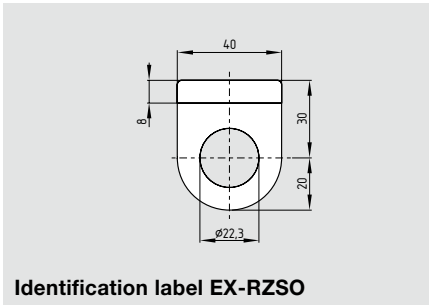

Ordering details

Mounting tool for mounting flange
Blanking plug

RMW
EX-RB











Ordering details

Identification label
Mounting flange

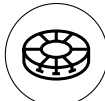





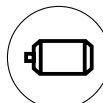

EX-RZSO
EX-RLM

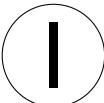
Control devices and indicator lights – Symbols

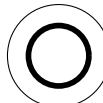

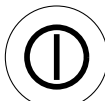
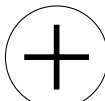
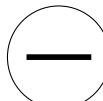







Drives

	401 Electric motor		402 Pump general		403 Gear pump		405 Coolant
	406 Oil lubrication		407 Rotary indexing table		408 Shuttle table forward		409 back
	410 Brake fan		411 Caution – live		412 Clamp table rectangular		413 Electrical machine

Signals

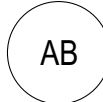
	501 On		502 Jog		503 Automatic		504 Off
	505 Everything off		506 On – off		507 Increase of a variable		508 Decrease of a variable
	509 Pause (time elapse)		510 Manual operation		511 Visual		512 Hydraulics

Words

	513		514		515		516
	517		518		519		520
	521		522		523		524



Letters¹

	901		902		903		904
---	------------	---	------------	---	------------	---	------------



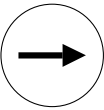
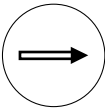

Other numerals available, e.g. for number 9 ordering code 709

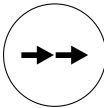
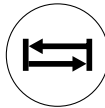
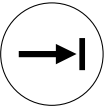
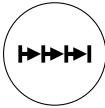
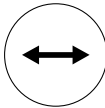
Control devices and indicator lights – Symbols

Linear motion

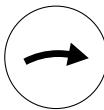
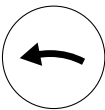
	101 Working motion feed		102 Rapid motion or idling		103 Rapid motion		104 Feed
	105 Interrupted motion jogging		106 Reciprocating motion				
	107 Limited motion		108 Indexing		109 Motion in 2 directions		

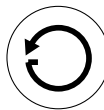
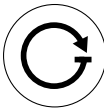
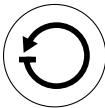
Rotary motion

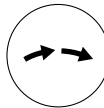
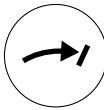
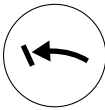
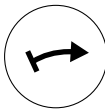
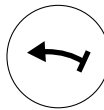
	201 Continuous clockwise rotation		202 Anti-clockwise rotation		203 Clockwise rotation STOP		204 Anti-clockwise rotation STOP
	205 1 revolution clockwise		206 Anti-clockwise		207 Rotary indexing		208 Interrupted rotary motion
	209 Clockwise motion restricted		210 Anti-clockwise motion restricted		211 Clockwise motion from a restriction		211 Anti-clockwise motion from a restriction

Additional options

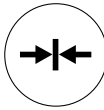
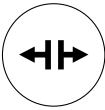
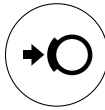
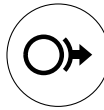
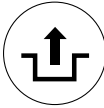
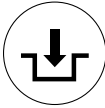
	301 Clamping, chucking		302 Release		303 Braking		304 Release brake
	305 Unlock		306 Lock				

Arabic numerals

	700		701		702		
	801		802		803		

More details



Detailed technical information at:
www.schmersal.net

Key transfer system

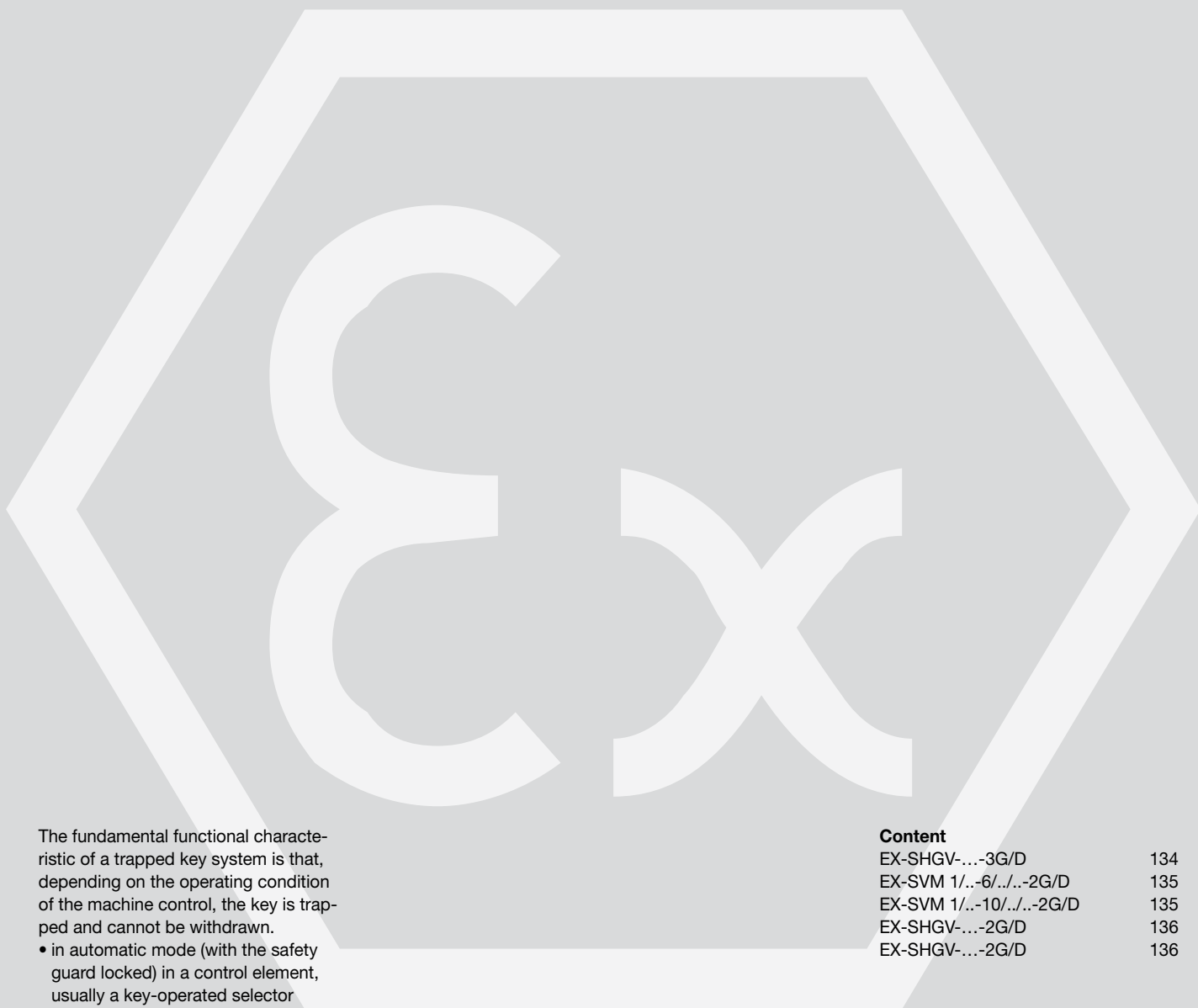

The fundamental functional characteristic of a trapped key system is that, depending on the operating condition of the machine control, the key is trapped and cannot be withdrawn.

- in automatic mode (with the safety guard locked) in a control element, usually a key-operated selector switch or
- if the safety guard is open (in an electrically de-energised condition), in the guard locking device, i.e. a lock

Content

EX-SHGV-...-3G/D	134
EX-SVM 1/...-6/...-2G/D	135
EX-SVM 1/...-10/...-2G/D	135
EX-SHGV-...-2G/D	136
EX-SHGV-...-2G/D	136

EX-Trapped key system



Mode of operation

The fundamental functional characteristic of a trapped key system is that, depending on the operating condition of the machine control, the key is trapped and cannot be withdrawn.

- in automatic mode (with the safety guard locked) in a control element, usually a key-operated selector switch or
- if the safety guard is open (in an electrically de-energised condition), in the guard locking device, i.e. a lock

In other words, a principle feature of the system is that the removable key is trapped either in the guard locking device or in the switch lock.

The locking device of the guard is designed in such a way that the trapped key can only be enabled if the guard is closed and locked (fail-safe). Only in this way can the key be transferred from here to the key-operated selector switch.

When the machine control system is switched on the key is trapped and cannot be removed for as long as the switch is set to ON.

If the transfer time between the opening of the key-operated selector switch and the locking of the guard is not sufficient for a hazardous machine motion to come to a standstill, a key-operated selector switch interlocking device may also be required.

Framework conditions

When using the EX-SHGV safety door interlocking system it must be ensured that

- the time between switching off at the control panel and access to the guard is greater than the stopping time of any hazardous motion, or that the key-operated selector switch interlocking device of the type SVE is used;
- only one key is used in the trapped key system and any spare keys available are stored carefully;
- the separate actuators of the EX-SHGV guard locking devices are fitted to the guard in such a way, e.g. with the non-reusable screws supplied with the equipment, that they cannot be released by simple means;
- the entry throat for the separate actuator is fitted in the guard locking device in a concealed position where at all possible. This recommendation applies generally to interlocking devices with separate actuator.

Please note:

- Owing to the trapped key system the systems are less suited to charging doors or moving guards with more frequent access.
- Even if key and lock barrel have 200 individual cuts / tumbler arrangements, a key can be copied in the same way as a separate actuator. Any damage caused as a result of such wilful manipulation of a guard no longer falls within the protection of statutory accident insurance (otherwise there would also be no BG test certificate for the SHGV system) for example.
- Every EX-SHGV system comes with a spare key should the original one be lost under the strict condition that it is kept carefully and not used in the operational key transfer procedure.

EX-Trapped key system



EX-SHG/ESS key-operated selector switch

The EX-SHG/ESS key-operated selector switch as control element to interrupt or switch off automatic mode.



Guard locking device Type EX-SHG

The design of the Guard locking device EX-SHG is based on that of a position switch with separate actuator, but the function of the position monitoring and locking is based exclusively on a mechanical principle of operation using the integrated lock barrel and the positively connected mechanism as well as the interaction between actuator and the articulating mechanism in the device head.



Version with a second lock barrel

The version with a second lock barrel using which the operation of lock barrel 1 can be blocked if an operator needs to access a room and wishes to protect himself from unintentional start-up of the machine control system by a third party.



EX-SVM key distribution station

The EX-SVM key distribution station is used when multiple guards must be operated with one key selector switch.

EX-Trapped key system

EX-SHGV-...-3G/D

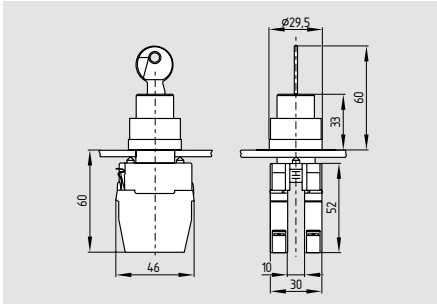

- Key-operated selector switch
- Ex certified
- Mounting hole 22.3 mm
- Metal front ring
- Good resistance to oil and petroleum spirit

Technical data

Equipment category: II 3GD
 Ex protection: Ex nL IIC T5 X
 Ex tD A22 IP65 T110°C X

Standards: EN 60947-1
 EN 60947-5-1
 EN 61241-1
 EN 60079-0
 EN 60079-15

Mounting hole \varnothing : 22.3 mm
 Front plate thickness: 1.5 ... max. 6 mm
 Spacing: 50 x 50 mm
 Max. impact energy: 1 J
 Actuating speed: max. 1 m/s

Protection class:
 Key-operated selector switch: IP65
 Contact element: IP44

Contact type: change-over contact
 with double break, type Zb,
 with galvanically separated
 contact bridges, NC contact
 with positive break

Contact material: fine silver

Connection: Screw terminals

U_i : 36 VDC
 I_i : 100 mA
 P_i : 0.9 W
 C_i : ~ 0
 L_i : ~ 0

Utilisation category: AC-15, DC-13
 I_e/U_e : 6 A / 250 VAC
 4 A / 24 VDC

Max. fuse rating: 6 A gG D-fuse
 Ambient temperature: 0 °C ... + 70 °C
 Mechanical life: 10 million operations

Contact variants

1 NO / 1 NC EF 103.1



EF 103.2



Gas zone 2 / Dust zone 22

Approvals



Ordering details

EX-SHGV/ESS21S2/①/11033-3G/D

No.	Option	Description
①	e.g. 201	individual key numbers

Note

Contact variants

Contact element EF103.1 1 NC / 1 NO
 Contact element EF103.2 1 NC / 1 NO
 included in delivery.

If more contacts are needed, on request.

EX-Trapped key system

EX-SVM 1/..-6/..-2G/D

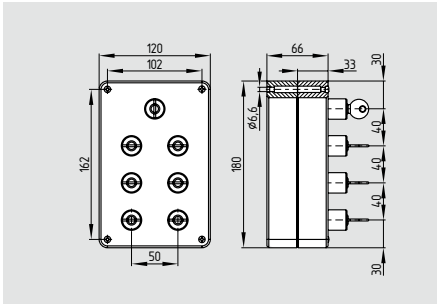
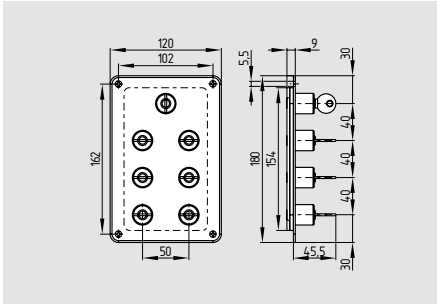

- Key distribution station
- with 6 keys
- Ex certified
- Metal enclosure
- Good resistance to oil and petroleum spirit
- Metal front plate
- 6 Cylinder lock for solenoid keys EX-SHGV.

EX-SVM 1/..-10/..-2G/D

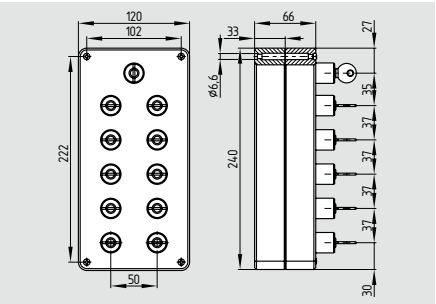
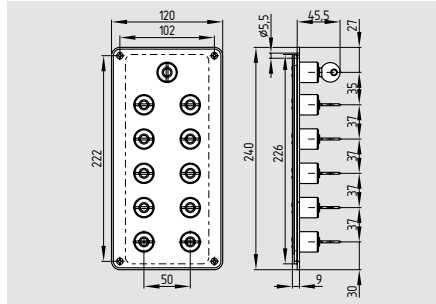

- Key distribution station
- with 10 keys
- Ex certified
- Metal enclosure
- Good resistance to oil and petroleum spirit
- Metal front plate
- 10 Cylinder lock for solenoid keys EX-SHGV.

Technical data

Equipment category: Ex II 2GD
 Ex protection: $c 85^{\circ}\text{C X}$
 Standards: EN 13463-1, EN 61241-0
 Design: Enclosure for top mounting or front plate mounting
 Material: Enclosure for top mounting AISI12 front plate 1.4301
 Actuating speed: max. 1 m/s
 Mechanical life: 10 million operations

Approvals



Approvals



Ordering details

EX-SVM1/①-6②/③-2G/D

No.	Option	Description
①	e.g. 34	individual key number for main cylinder lock
②	...	individual key number for solenoid key EX-SHGV.
③	A	Enclosure for surface mounting
	E	Front plate mounting

Ordering details

EX-SVM1/①-10②/③-2G/D

No.	Option	Description
①	e.g. 34	individual key number for main cylinder lock
②	...	individual key number for solenoid key EX-SHGV.
③	A	Enclosure for surface mounting
	E	Front plate mounting

EX-Trapped key system

EX-SHGV-...-2G/D

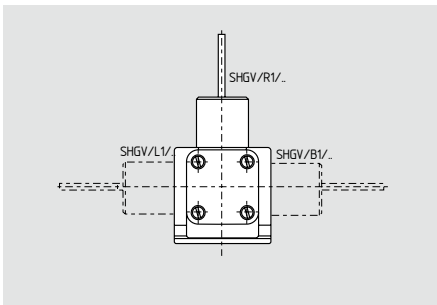
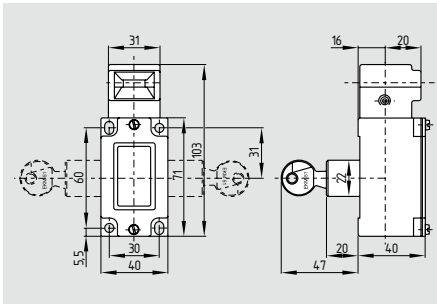

- Interlock
- Ex certified
- Mounting details to EN 50041
- Metal enclosure
- Good resistance to oil and petroleum spirit

EX-SHGV-...-2G/D

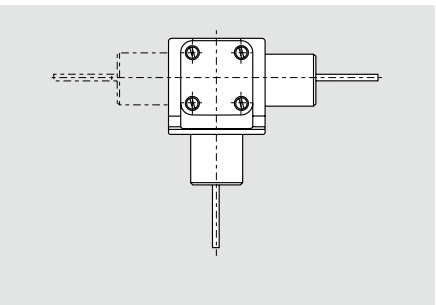
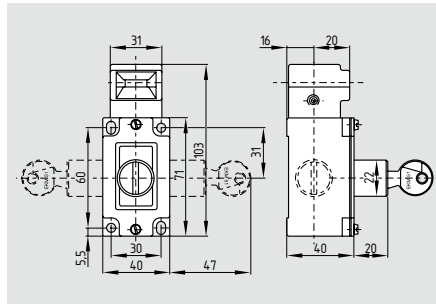

- Interlock
- with a second lock barrel

Technical data

Equipment category: Ex II 2GD
 Ex protection: $c 85^\circ\text{C X}$
 Standards: EN 13463-1, EN 61241-0
 Design: fixings to EN 50041
 Enclosure: Al Si12 die-casting, painted
 Actuating speed: max. 1 m/s
 Mechanical life: 10 million operations

Approvals



Approvals



Ordering details

EX-SHGV/①01/②+③-2G/D

No.	Option	Description
①	B	Cylinder lock on the back
	L	Lock barrel to left
	R	Lock barrel to the right
②	e.g. 201	individual key numbers
③	e.g. BO	For the appropriate actuator see page 137

EX-SHGV/①D1/①/③+④-2G/D

No.	Option	Description
①	L	Lock barrel to left
	R	Lock barrel to the right
②	e.g. 201	individual key number for LHS or RHS cylinder lock
③	e.g. 34	individual key number for second cylinder lock
④	e.g. BO	For the appropriate actuator see page 137

EX-Trapped key system

System components

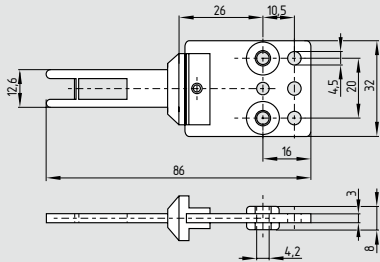

Straight actuator EX-BO

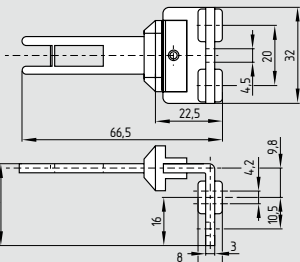

Angled actuator EX-BOW

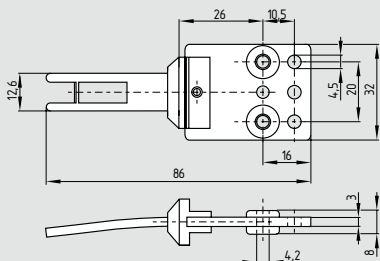

Straight radius actuator EX-BOR

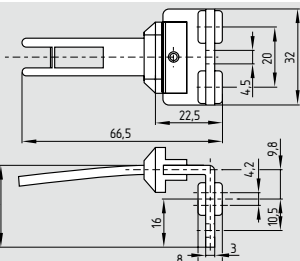

Angled radius actuator EX-BOWR

Ordering details

Straight actuator	EX-BO
Angled actuator	EX-BOW
Straight radius actuator	EX-BOR
Angled radius actuator	EX-BOWR

Addresses

■ **Hauptsitz - Headquarters**
K.A. Schmersal GmbH & Co. KG
Industrielle Sicherheitssysteme
 Postfach 24 02 63,
 42232 Wuppertal
 Möddinghofe 30
 D-42279 Wuppertal
 Phone: +49-2 02-64 74-0
 Fax: +49-2 02-64 74-1 00
 info@schmersal.com
 www.schmersal.com

Germany - Northern region

■ **Wettenberg**
K.A. Schmersal GmbH & Co. KG
Vertriebsbüro Wettenberg
 Im Ostpark 2
 D-35435 Wettenberg
 Phone: +49-6 41-98 48-5 75
 Fax: +49-6 41-98 48-5 77
 vbwettenberg@schmersal.com

■ **Hamburg / Münster**
K.A. Schmersal GmbH & Co. KG
Vertriebsbüro Hamburg
 Innungsstraße 3
 D-21244 Buchholz i.d.N.
 Phone: +49-41 81-9 22 0-0
 Fax: +49-41 81-9 22 0-20
 vbhamburg@schmersal.com

■ **Berlin**
**KSA Komponenten der Steuerungs-
 und Automatisierungstechnik GmbH**
 Pankstr. 8-10 / Aufg. L
 D-13127 Berlin
 Phone: +49-30-47 48 24 00
 Fax: +49-30-47 48 24 05
 info@ksa-gmbh.de
 www.ksa-gmbh.de

■ **Hannover**
ELTOP GmbH
 Robert-Bosch-Str. 8
 D-30989 Gehrden
 Phone: +49-51 08-92 73 20
 Fax: +49-51 08-92 73 21
 eltop@eltop.de
 www.eltop.de

■ **Köln**
Stollenwerk
Technisches Büro GmbH
 Scheuermühlenstr. 40
 D-51147 Köln
 Phone: +49-22 03-9 66 20-0
 Fax: +49-22 03-9 66 20-30
 info@stollenwerk.de
 www.stollenwerk.de

■ **Siegen**
Siegfried Klein
Elektro-Industrie-Vertretungen
 In der Steinwiese 46
 D-57074 Siegen
 Phone: +49-2 71-67 78
 Fax: +49-2 71-67 70
 info@sk-elektrotechnik.de
 www.sk-elektrotechnik.de

■ **Leipzig**
K.A. Schmersal GmbH & Co. KG
Vertriebsbüro Leipzig
 Servicepark
 Druckereistraße 4
 D-04159 Leipzig
 Phone: +49-3 41-4 87 34 50
 Fax: +49-3 41-4 87 34 51
 vbleipzig@schmersal.com

Germany - Southern region

■ **Nürnberg**
K.A. Schmersal GmbH & Co. KG
Vertriebsbüro Nürnberg
 Lechstraße 21
 D-90451 Nürnberg
 Phone: +49-9 11- 6 49 60 53
 Fax: +49-9 11-63 29 07 29
 vbnuernberg@schmersal.com

■ **Saarland**
**Herbert Neundörfer Werks-
 vertretungen GmbH & Co. KG**
 Am Campus 5
 D-66287 Göttingen
 Phone: +49-68 25-95 45-0
 Fax: +49-68 25-95 45-99
 info@herbert-neundoerfer.de
 www.herbert-neundoerfer.de

■ **Bayern Süd**
INGAM Ing. Adolf Müller GmbH
Industrievertretungen
 Elly-Staegmeyr-Str. 15
 D-80999 München
 Phone: +49-89-8 12 60 44
 Fax: +49-89-8 12 69 25
 info@ingam.de
 www.ingam.de

■ **Bietigheim**
K.A. Schmersal GmbH & Co. KG
Technologiezentrum
 Pleidelsheimer Straße 15
 74321 Bietigheim-Bissingen
 Phone: +49-71 42-9 10 28-0
 Fax: +49-71 42-9 10 28-28
 tzbw@schmersal.com

Europe

■ **Austria - Österreich**
AVS-Schmersal Vertriebs Ges. m.b.H.
 Biröstraße 17
 1232 Wien
 Phone: +43-1-6 10 28
 Fax: +43-1-6 10 28-1 30
 info@avs-schmersal.at
 www.avs-schmersal.at

■ **Belgium - Belgien**
Schmersal Belgium NV/SA
 Nieuwlandlaan 73
 Industriezone B413
 3200 Aarschot
 Phone: +32-16-57 16 18
 Fax: +32-16-57 16 20
 info@schmersal.be
 www.schmersal.be

■ **Bulgaria - Bulgarien**
CDL Sensorik OOD
 Stefan Caragea Street
 No 10 Office 4
 7002 Ruse City
 Phone: +359-0 40-7 35 16 55 25
 Fax: +359-0 40-2 69 25 33 44
 office@cdlsensorik.com
 www.cdlsensorik.com

■ **Bosnia and Herzegovina**
Tipteh d.o.o. Sarajevo
 Ulica Branilaca Šipa 21c
 71000 Sarajevo
 Phone: +387- 61 92 36 23
 nadir.durmic@tipteh.ba
 www.tipteh.ba

■ **Croatia - Kroatien**
Tipteh Zagreb d.o.o.
 Pescanska 170
 10000 Zagreb
 Phone: +385-1-3 81 65 74
 Fax: +385-1-3 81 65 77
 tipteh.zagreb@zg.t-com.hr

■ **Czech Republic - Tschech. Republik**
MERCOM COMPONENTA s.r.o.
 Bechyňská 640
 199 00 Praha 9 – Letňany
 Phone: +4 20- 267 31 46 40-2
 mercom@mercom.cz
 www.mercom.cz
 www.schmersal.cz

■ **Denmark - Dänemark**
Schmersal Danmark A/S
 Lautruphøj 1-3
 2750 Ballerup
 Phone: +45-70 20 90 27
 Fax: +45-70 20 90 37
 info@schmersal.dk
 www.schmersal.dk

■ **Finland - Finnland**
Advancetec Oy
 Äyritie 12 B
 01510 Vantaa
 Phone: +3 58-2 07 19 94 30
 Fax: +3 58-9 35 05 26 60
 advancetec@advancetec.fi
 www.schmersal.fi

■ **France - Frankreich**
Schmersal France
 BP 18 - 38181 Seyssins Cedex
 8, rue Raoul Follereau
 38180 Seyssins
 Phone: +33-4 76 84 23 20
 Fax: +33-4 76 48 34 22
 info-fr@schmersal.com
 www.schmersal.fr

■ **Greece - Griechenland**
Kalamarakis Sapounas S.A.
Ionias & Neromilou
 PO Box 46566 Athens
 13671 Chamomilos Acharnes
 Athens
 Phone: +30-210-2 40 60 00-6
 Fax: +30-210-2 40 60 07
 ksa@ksa.gr
 www.ksa.gr

■ **Hungary - Ungarn**
**NTK Ipari-Elektronikai és
 Kereskedelmi Kft**
 Gesztenyefa u. 4.
 9027 Győr
 Phone: +36-96-52 32 68
 Fax: +36-96-43 00 11
 info@ntk-kft.hu
 www.ntk-kft.hu

■ **Iceland - Island**
Reykjafell Ltd.
 Skipholt 35
 125 Reykjavik
 Phone: +354-5 88 60 10
 Fax: +354-5 88 60 88
 reykjafell@reykjafell.is

■ **Italy - Italien**
Schmersal Italia s.r.l.
 Via Molino Vecchio, 206
 25010 Borgosatollo, Brescia
 Phone: +39-0 30-2 50 74 11
 Fax: +39-0 30-2 50 74 31
 info@schmersal.it
 www.schmersal.it

■ **Macedonia - Mazedonien**
Tipteh d.o.o. Skopje
 Ul. Jani Lukrovski br. 2/33
 1000 Skopje
 Phone: +389-70-39 94 74
 Fax: +389-23-17 41 97
 tipteh@on.net.mk

■ **Netherlands - Niederlande**
Schmersal Nederland B.V.
 Lorentzstraat 31
 3846 AV Harderwijk
 Phone: +31-3 41-43 25 25
 Fax: +31-3 41-42 52 57
 info-nl@schmersal.com
 www.schmersal.nl

■ **Norway - Norwegen**
Schmersal Norge
 Hoffsvæien 92
 0377 Oslo
 Phone: +47-22 06 00 70
 Fax: +47-22 06 00 80
 info-no@schmersal.com
 www.schmersal.no

■ **Poland - Polen**
Schmersal - Polska Sp.j.
 ul. Baletowa 29
 02-867 Warszawa
 Phone: +48-22-8 16 85 78
 Fax: +48-22-8 16 85 80
 info@schmersal.pl
 www.schmersal.pl

■ **Portugal - Portugal**
Schmersal Ibérica, S.L.
 Apartado 30
 2626-909 Póvoa de Sta. Iria
 Phone: +351 - 21 959 38 35
 info-pt@schmersal.com
 www.schmersal.pt

■ **Romania - Rumänien**
CD SENSORIC SRL
 Str. George Enescu 21
 550248 Sibiu
 Phone: +40-2 69-25 33 33
 Fax: +40-2 69-25 33 44
 proiecte@cdl.ro
 www.cdl.ro

■ **Russia - Russland**
OOO AT electro Moskau
 ul. Avtosavodskaya 16-2
 109280 Moskau
 Phone: +7-49 5-9 21 44 25
 Fax: +7-49 5-9 26 46 45
 info@at-e.ru
 www.at-e.ru

OOO AT electro Petersburg
 Polytechniskaya str, d.9,B
 194021 St. Petersburg
 Phone: +7-81 2-7 03 08 17
 Fax: +7-81 2-7 03 08 34
 spb@at-e.ru

AT- Electronics Ekaterinburg
 Bebelya str. 17, room 405
 620034 Ekaterinburg
 Phone: +7-34 3-2 45 22 24
 Fax: +7-34 3-2 45 98 22
 ural@at-e.ru

■ **Slovakia - Slowakei**
MERCOM COMPONENTA s.r.o.
 Bechyňská 640
 199 00 Praha 9 – Letňany
 Phone: +4 20-267 31 46 40-2
 mercom@mercom.cz
 www.mercom.cz
 www.schmersal.cz

■ **Slovenia - Slowenien**
Tipteh d.o.o.
 Ulica Ivana Roba 21
 1000 Ljubljana
 Phone: +386-1-2 00 51 50
 Fax: +386-1-2 00 51 51
 info@tipteh.si
 www.tipteh.si

■ **Spain - Spanien**
Schmersal Ibérica, S.L.
Po. Ind. La Masia
 Camí de les Cabòries, Nave 4
 08798 Sant Cugat Sesgarrigues
 Phone: +34-902 56 64 57
 info-es@schmersal.com
 www.schmersal.es

■ **Sweden - Schweden**
Schmersal Nordiska AB
 F O Petersons gata 28
 421 31 Västra Frölunda
 Phone: +46-31-3 38 35 00
 Fax: +46-31-3 38 35 39
 info-se@schmersal.com
 www.schmersal.se

■ **Switzerland - Schweiz**
Schmersal Schweiz AG
 Moosmattstraße 3
 8905 Arni
 Phone: +41-43-3 11 22 33
 Fax: +41-43-3 11 22 44
 info-ch@schmersal.com
 www.schmersal.ch

Addresses

- **Turkey - Türkei**
BETA Elektrik
Okcumusa Caddesi
Anten Han No. 44
34420 Karaköy / Istanbul
Phone: +90-212-235 99 14
Fax: +90-212-253 54 56
info@betaelektrik.com
www.betaelektrik.com
- **United Kingdom - Großbritannien**
Schmersal Ltd.
Sparrowhawk Close
Enigma Business Park
Malvern Worcestershire WR14 1GL
Phone: +44-16 84-57 19 80
Fax: +44-16 84-56 02 73
support@schmersal.co.uk
www.schmersal.co.uk
- **Ukraine - Ukraine**
INCOMTECH-PROJECT Ltd
17-25, Hertsena St., of. 9
04050 Kyiv Ukraine
Phone: +38 044 486 2537
www.i-p.com.ua/
- VBR Ltd.**
41, Demiyivska Str.
03040 Kyiv Ukraine
Phone: +38 (044) 259 09 55
Fax: +38 (044) 259 09 55
office@vbr.com.ua
www.vbr.com.ua/about_en.htm
- **Chile - Chile**
Vitel S.A.
francisco@vitel.cl
www.vitel.cl
SOLTEX
central@soltext.cl
www.soltext.com.cl
INSTRUTEC
gcaceres@instrutec.cl
www.instrutec.cl
OEG
jmp@oegggroup.com
www.oegggroup.cl
EECOL INDUSTRIAL ELECTRIC
ventas@eecol.cl
www.eecol.cl
- **PR China - VR China**
Schmersal Industrial Switchgear (Shanghai) Co. Ltd.
Cao Ying Road 3336
201712 Shanghai / Qingpu
Phone: +86-21-63 75 82 87
Fax: +86-21-63 75 82 97
sales@schmersal.com.cn
www.schmersal.com.cn
- **Colombia - Kolumbien**
EQUIPELCO
aospina@equipelco.com
www.equipelco.com
SAMCO
jvargas@samcoingenieria.com
www.samcoingenieria.com
- **Ecuador - Ecuador**
SENSORTEC S.A
AV. Napo y Pinto Guzmán
Quito
Phone: +593 091 40 27 65
+593 095 04 86 11
infogy@sensortecsa.com
www.sensortecsa.com
- **Guatemala - Guatemala**
PRESTELECTRO
AV Petapa 44-22,
Zona 12; Cent. Com Florencia 01012
Phone: +502 24 42-33 46
Anabella.Barrios@prestelectro.com
www.prestelectro.com
- **India - Indien**
Schmersal India Private Limited
Plot No G 7/1,
Ranjangaon MIDC,
Taluka Shirur,
District Pune 412220, India
Phone: +91 21 38 61 47 00
Fax: +91 20 66 86 11 14
info-in@schmersal.com
www.schmersal.in
- **Indonesia - Indonesien**
PT. Wiguna Sarana Sejahtera
Jl. Daan Mogot Raya No. 47
Jakarta Barat 11470
Phone: +62-21-5 63 77 70-2
Fax: +62-21-5 66 69 79
email@ptwiguna.com
www.ptwiguna.com
- **Israel - Israel**
A.U. Shay Ltd.
23 Imber St. Kiriat. Arieah.
P.O. Box 10049
Petach Tikva 49222 Israel
Phone: +9 72-3-9 23 36 01
Fax: +9 72-3-9 23 46 01
shay@uriel-shay.com
www.uriel-shay.com
- **Japan - Japan**
Schmersal Japan Branch Office
3-39-8 Shoan, Suginami-ku
Tokyo 167-0054
Phone: +81-3-3247-0519
Fax: +81-3-3247-0537
safety@schmersaljp.com
www.schmersal.jp
- **Korea - Korea**
Mahani Electric Co. Ltd.
20, Gungmal-ro, Gwacheon-si,
Gyeonggi-do 427-060, Korea
Phone: +82-2-21 94-33 00
Fax: +82-2-21 94-33 97
yskim@mec.co.kr
www.mec.co.kr
- **Litauen/Estland/Lettland**
BOPLALIT
Mus galite rasti:
Baltų pr. 145, LT-47125, Kaunas
Phone: +370 37 298989
Phone: +370 37 406718
infoboplalit.lt
www.boplalit.lt
- **Malaysia - Malaysien**
Ingermark (M) SDN.BHD
No. 29, Jalan KPK 1/8
Kawasan Perindustrian Kundang
48020 Rawang, Selangor Darul Ehsan
Phone: +6 03-60-34 27 88
Fax: +6 03-60-34 21 88
enquiry@ingermark.com
- **Mexico - Mexiko**
ISEL SA de CV
mario.c@isel.com.mx
www.isel.com.mx
INNOVATIVE AUTOMOTION SOLUTIONS
ias@iasmx.com
www.iasautomation.com.mx
EASA ENERGIA Y AUTOMATIZACIÓN
ias@iasmx.com
www.iasautomation.com.mx
DINAMICA S.A de C.V
ias@iasmx.com
www.iasautomation.com.mx
SIGRAMA S.A de C.V
ias@iasmx.com
www.iasautomation.com.mx
VGR TECHNOLOGIES
ias@iasmx.com
www.iasautomation.com.mx
- **New Zealand - Neuseeland**
Hamer Automation
85A Falsgrave Street
Philipstown
Christchurch, New Zealand
Phone: +64-33 66 24 83
Fax: +64-33 79 13 79
sales@hamer.co.nz
www.hamer.co.nz
- **Pakistan - Pakistan**
eurotech JLT
Office No.3404, 34th Floor,
HDS Tower, Sheikh Zayed Road,
Jumeirah Lakes Towers (JLT),
P.O.Box 643650, Dubai, UAE
Phone: +9 71-4-4 21 46 00
Fax: +9 71-4-4 21 46 01
sales@eurotech.ae
www.eurotech.ae
- **Paraguay - Paraguay**
Brasguay S.R.L.
R. Internaciona 07
KM 14 ; Minga Guazu
Phone: +595 (61) 583-418/218/577
brasguay@brasguay.com.py
www.brasguay.com.py
- **Peru - Peru**
Fametal S.A.
fametal@fametal.com
www.fametal.com
AYD
informes@ayd.com.pe
www.ayd.com.pe
- **Serbia/Montenegro - Serbien/Montenegro**
Tipteh d.o.o.
Toplice Milana 14A
11050 Belgrade
Phone: +3 81-11-2 89 22 50
Fax: +3 81-11-3 01 83 26
www.tipteh.rs
- **Singapore - Singapur**
AZAREL International Pte Ltd.
Empire Techno Centre
30 Kaki Bukit Road 3 #01-10
Singapore 417819
Phone: +65-67 42 29 88
Fax: +65-67 42 26 28
sales@azarel.com.sg
www.azarel.com.sg
- **South Africa - Südafrika**
A+A Dynamic Distributors (Pty) Ltd.
20 - 24 Augusta Road
Regents Park
2197 Booyens
Phone: +27-11-6 81 59 00
Fax: +27-11-4 35 13 18
awkayser@iafrica.com
- **Taiwan - Taiwan**
Golden Leader Camel Ent. Co., Ltd.
No. 453-7, Pei Tun Rd.
Taichung City 40648, Taiwan
Phone: +886-4-22 41 29 89
Fax: +886-4-22 41 29 23
camel88@ms46.hinet.net
www.leadercamel.com.tw
- **Thailand - Thailand**
M. F. P. Engineering Co. Ltd.
64-66 Buranasart Road
Sanchoaporsva
Bangkok 10200
Phone: +66-2-2 26 44 00
Fax: +66-2-2 25 67 68
info@mfpthai.com
www.mfpthai.com
- **United Arab Emirates - Vereinigte Arabische Emirate**
eurotech JLT
Office No.3404, 34th Floor,
HDS Tower, Sheikh Zayed Road,
Jumeirah Lakes Towers (JLT),
P.O.Box 643650,
Dubai, UAE
Phone: +9 71-4-4 21 46 00
Fax: +9 71-4-4 21 46 01
sales@eurotech.ae
www.eurotech.ae
- **USA - USA**
Schmersal Inc.
15 Skyline Drive
Hawthorne, NY 10532
Phone: +1-(0) 8 88-4 96-51 43
Fax: +1-(0) 9 14-3 47-15 67
infousa@schmersal.com
www.schmersalusa.com
- **Uruguay - Uruguay**
Gliston S.A.
Pedemal 1896 - Of. 203
Montevideo
Phone: +598 (2) 2 00 07 91
colmedo@gliston.com.uy
www.gliston.com.uy
- **Venezuela - Venezuela**
EMI Equipos y Sistemas C.A.
Calle 10, Edf. Centro Industrial
Martinisi, Piso 3, La Urbina
Caracas
Phone: +58 (212) 2 43 50 72
ventas@emi-ve.com
www.emi-ve.com
- **Vietnam - Vietnam**
Ingermark (M) Sdn Bhd, Rep Office
No. 10 Alley 1/34, Lane 1,
Kham Thien Str.,
Kham Thien Ward Dong Da Dist.,
10000 Hanoi, Vietnam.
Phone: +04-35 16 27 06
Fax: +04-35 16 27 05
ingvietn18@ymail.com
www.ingermark.com

Worldwide



The Schmersal Group

The privately-owned Schmersal Group has been developing and manufacturing products to enhance the safety at work for decades. The company was founded in 1945 and is represented by seven manufacturing sites on three continents and with its own companies and sales partners in more than 60 nations. In the demanding field of machine safety, the Schmersal Group is one of the international market and competence leaders. Based on a comprehensive product range, the company's approximately 2000 employees develop and design complete solutions for the safety of man and machine.

Customers of the Schmersal Group include „global players“ from mechanical engineering and plant manufacturing and machine users. They benefit from the comprehensive know-how of the company when it comes to the standard-compliant integration of safety technology in the production processes. Furthermore, Schmersal has special sector expertise in the application fields that demand high quality and special characteristics from safety switching systems. These include food production, the packaging industry, machine tool construction, lift engineering, heavy industry and the automotive industry.

Against the backdrop of increasing numbers of standards and directives, tec.nicum offers a comprehensive range of safety services as part of the Schmersal Group services division: Certified functional safety engineers advise customers on selecting suitable safety equipment, CE compliance assessments and risk assessment, on a word-wide basis.

Product ranges



Safe switching and monitoring

- Guard door monitoring (Safety switches)
- Command devices with safety function
- Tactile safety devices
- Optoelectronic safety devices

Safe signal processing

- Safety relay components
- Safety controllers
- Safety bus systems

Automation

- Position detection
- Command and signalling devices

Industries



- Elevators and Escalators
- Packaging
- Food
- Automotive
- Machine tools
- Heavy industry

Services



- Application support
- CE conformity assessment
- Risk assessment
- Upgrading / Retrofit
- Technical planning and implementation
- Training courses

Competences



- Machine safety
- Automation
- Explosion protection
- Hygienic design

www.schmersal.com



 **SCHMERSAL**
Safe solutions for your industry

