

LARGE HINGED WINDOW ENCLOSURE

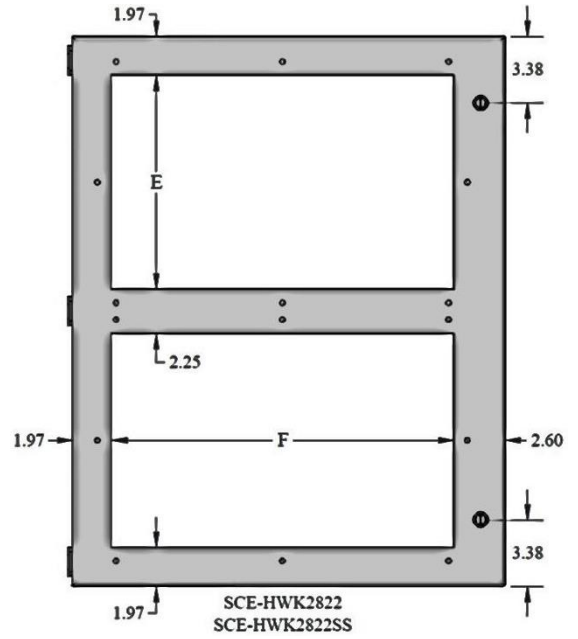

CATALOG NUMBER	A	B	C	D	E	F
SCE-HWK2228 SCE-HWK2228SS	22.00	28.00	10.25	13.25	18.00	10.56
SCE-HWK2822 SCE-HWK2822SS	28.00	22.00	13.25	10.25	10.88	17.38

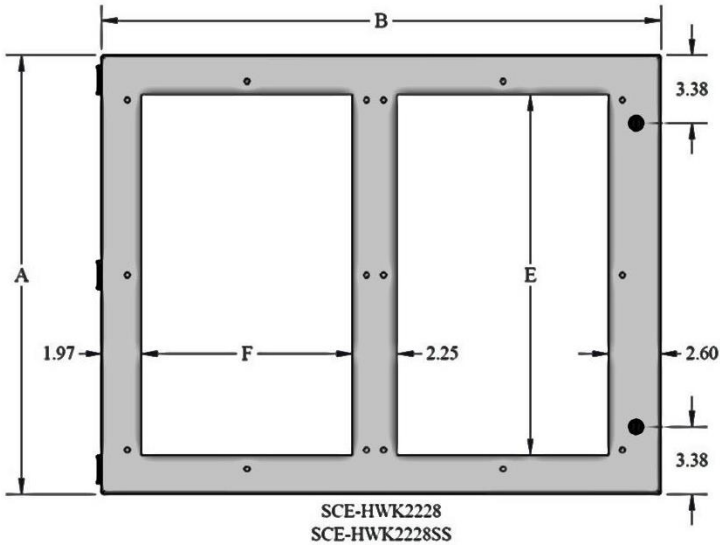
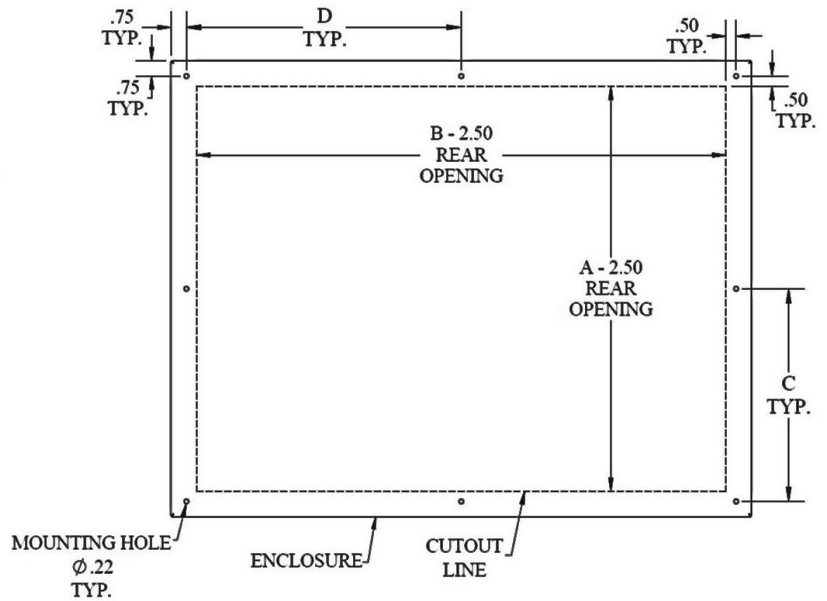
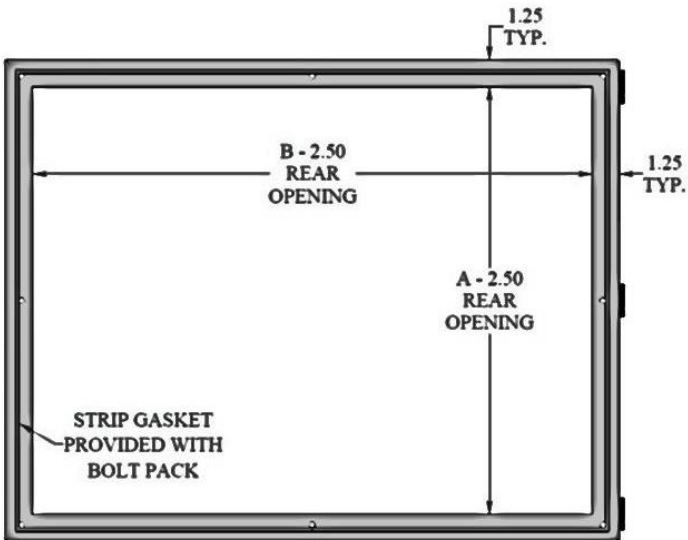

LARGE HINGED WINDOW ENCLOSURE

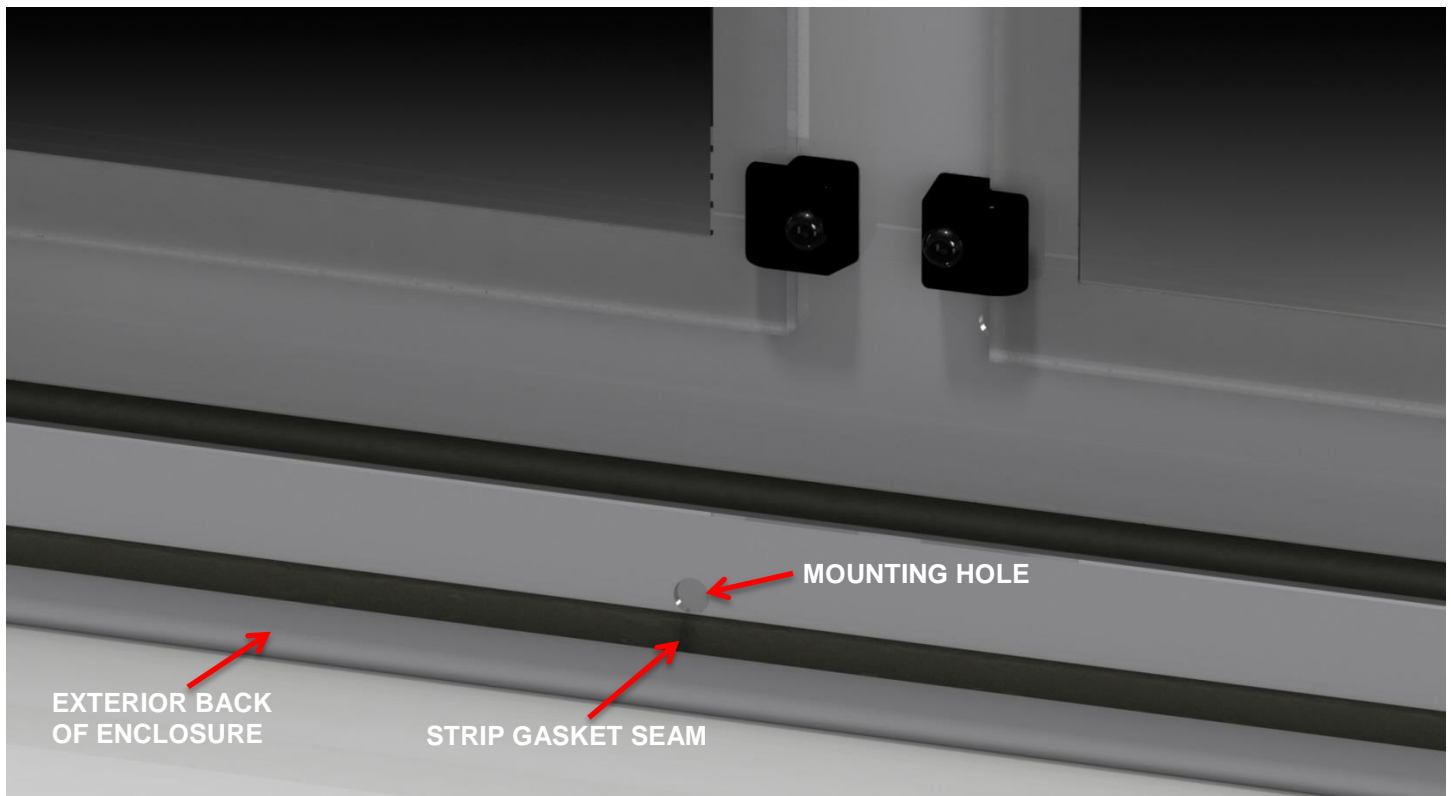

- A. Apply strip gasket provided with bolt pack to the exterior back of the enclosure.
- B. Start applying the strip gasket centered at the bottom of the enclosure.
- C. The strip gasket needs to be applied in one continuous path, on the outside of each mounting hole.
- D. End with the strip gasket seam centered at the bottom of the enclosure, flush to the starting point.