



User Manual SCE-HE08W120V

- 1. User Manual p. 2
- 2. Legal Regulations p. 2
- 3. Safety Instructions p. 3
- 4. Technical Information p. 4
- 5. Functional Principle p. 4
- 6. Technical Data p. 5
- 7. Performance Graph p. 6
- 8. Mounting p. 7
- 9. Mounting Principle p. 7
- 10. Cutout Dimensions p. 8
- 11. Dimensions (H x W x D) p. 8
- 12. Electrical Connection p. 9
- 13. Controller Programming p. 9
- 14. Wiring Diagram p. 12
- 15. Taking Into Operation p. 14
- 16. Repair p. 14
- 17. Maintenance & Cleaning p. 15
- 18. Transportation & Storage p. 16
- 19. Parts Supplied p. 16
- 20. Warranty / Limits of Liability p. 17



1. User Manual

This instruction manual contains information and instructions to enable the user to work safely, correctly and economically on the unit. Understanding and adhering to the manual can help one:

- Avoid any dangers
- Reduce repair costs and stoppages
- Extend and improve the reliability and working life of the unit

PLEASE ENSURE TO USE THE RIGHT VERSION OF THE INSTRUCTION MANUAL SUITABLE FOR YOUR UNIT

Conditions of Use

The unit is to be used exclusively for the dissipation of heat from control cabinets and enclosures in order to protect temperature sensitive components in an industrial environment. To meet the conditions of use, all the information and instructions in the instruction manual must be adhered to.



General Danger

Indicates compulsory safety regulations which are not covered by a specific pictogram such as one of the following.



High Electric Voltage

Indicates electric shock danger.



Important Safety Instruction

Indicates instructions for safe maintenance and operation of the unit.



Attention

Indicates possible burns from hot components.



Attention

Indicates possible damage to the unit.



Instruction

Indicates possible danger to the environment.

2. Legal Regulations

Liability

The information, data and instructions contained in this instruction manual are current at the time of going to press. We reserve the right to make technical changes to the unit in the course of its development. Therefore, no claims can be accepted for previously delivered units based on the information, diagrams or descriptions contained in this manual. No liability can be accepted for damage and production caused by:

- Disregarding the instruction manual
- Operation error
- Inappropriate work on or with the unit
- The use of non-specified spare parts and accessories
- Unauthorized modifications or changes to the unit by the user or his personnel

Saginaw Control & Engineering is only liable for errors and omissions as outlined in the guarantee conditions contained in the main contractual agreement. Claims for damages on any grounds are excluded.

3. Safety Instructions

Upon delivery the unit is already meeting current technical standards, therefore it can be safely taken into operation. Only trained specialists are allowed to work on the unit. Unauthorized personnel must be prohibited from working on the unit. Operating personnel must inform their superiors immediately if any malfunction of the unit becomes apparent.

Please note that before starting to work on or with the unit, a procedure must be carried out inside the cabinet on which the unit is to be mounted.

Before commencing work inside the cabinet, the control cabinet manufacturer's instruction must be read with regards to:

- Safety instructions
- Instructions on taking the cabinet out of operation
- Instructions on the prevention of unauthorized cabinet reconnection

The electric equipment meets the valid safety regulations. One can find dangerous voltage (above 50V AC or above 100V DC):

- Behind the control cabinet doors
- On the power supply in the unit housing

The units have to be fused according to the type plate and the wiring diagram. Switch the unit **off** immediately if the electric power supply is interrupted.



Danger Through Incorrect Work on the Unit

Only specialized personnel are allowed to maintain and clean the unit. Regular maintenance and cleaning must be kept in order to ensure that the unit remains in perfect working condition and has a long working life.



Danger from Electric Voltage

Only specialized personnel are allowed to maintain and clean the unit. The personnel must ensure that for the duration of the maintenance and cleaning, the unit is disconnected from the electrical supply.



Attention

Damage to the unit through the use of inappropriate cleaning materials. Please do not use aggressive cleaning material.



Instruction

Damage to the environment through unauthorized disposal. All spare parts and associated material must be disposed of according to the environmental laws.

4. Technical Information

Concise Unit Description

Heat Exchangers are used where the heat generated by energy losses in control cabinets must be conducted away to protect temperature-sensitive components. The characteristics graph shown in the "Performance Characteristics" section applies to external (ambient) air as the coolant

In Air-to-Air Heat Exchangers, the internal temperature of the control cabinet cannot be cooler than the ambient temperature. There are natural limits to the cooling performance, dependent on the air supply temperature and the requirement for a temperature difference of at least 9° F. Unlike systems in which the heat generated is allowed to escape by air convection through ventilation slots, with the Heat Exchanger, the clean air inside the control cabinet is prevented from mixing with the air outside, which may well be unclean.

5. Functional Principle

Functional Principle

The Heat Exchanger is a cooling device that creates a heat-transfer through a large area of thin aluminum sheet metal folded up in the Heat Exchanger core by means of forced convection. Used within an enclosure, it uses the ambient air as the cooling medium, thus avoiding the utilization of refrigerant.

The cooling performance of the Heat Exchanger is dependant on the ambient (external) air temperature. The internal fan is set to be always on. The external fan is controlled via a controller. When the cabinet temperature increases beyond the pre-set thermostat temperature, the external fan is switched on and the Heat Exchanger starts cooling. Cooling stops when the cabinet temperature cools below the pre-set temperature. Switching difference is 5.4° F.

6. Technical Data

Part Number	SCE-HE08W120V
Specific Performance	8 W/F
Operating Temperature Range	23°F - 131°F
Mounting	External
Housing Material	Mild Steel, Powder Coated
Dimensions (H x W x D)	29.50 x 10.00 x 5.95 inch
Weight	25.0 lbs
Rated Operating Voltage / Frequency	120 V - 50/60 Hz
Rated Current	1.10 A
Starting Current	1.30 A
Power Consumption	120 W
Fuse Rating	1.6A (T) - Time Delayed [Slow Acting]
Circuit Breaker - MCB Type D or K Slow Acting	1.6A Slow Acting
Connection	Cage Clamp Terminal Connector
NEMA Protection Class	NEMA 3, 3R & 12
Approvals	CE / cURus
Industry Standards	IS22
Max Voltage at Door Switch	5 A DC

7. Performance Graph

Enviro-Therm® Heat Exchangers 08 W/F Performance Curve

SCE-HE08W120V

T = Temperature difference between ambient and internal temperature
P = Heat Exchanger performance

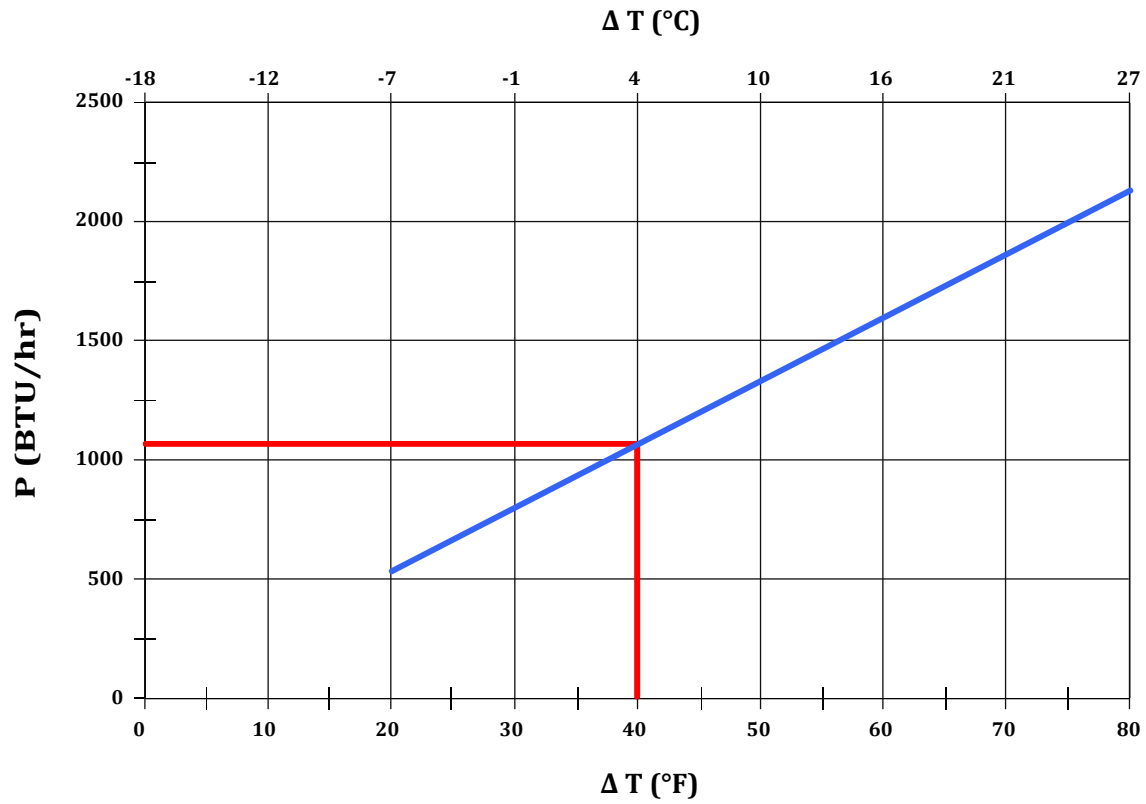

8. Mounting



Danger from Electrical Voltage

The unit must be mounted by specialized personnel (qualified electricians). The personnel must ensure that the cabinet is disconnected from the electrical supply for the duration of the mounting operation. Therefore, take the cabinet out of operation, following the relevant instructions before mounting work commences.



Danger Through Incorrect Work on the Unit

Only specialists are allowed to put the unit into operation.

Mounting Preparations

Several points must be checked before the unit can be mounted. These checks must be made to ensure safety and the trouble-free operation of the unit. These checks must be carried out with absolute thoroughness to ensure that the unit works perfectly.

Transport Damage Check

Upon delivery, the carton containing the unit must be examined for signs of transport damage. Any transport damage to the carton could indicate that the unit itself has been damaged in transit, which in the worst case could mean the unit will not function.

Location and Space Requirements

The location of the cabinet must allow for sufficient air circulation to and from the unit. The unit should be mounted roughly horizontally. It is therefore advisable to check that the cabinet is in a horizontal position. The max deviation from the vertical or horizontal should not exceed 20 degrees.

Sealing

To guarantee that the unit works perfectly, ensure that the control cabinet is completely sealed (min NEMA 12) and that a good seal exists between the control cabinet and the unit. If necessary, the cabinet mounting surface should be reinforced.

9. Mounting Principle

1. Heat Exchanger
2. Mounting Gasket
3. Slotted Stud M6 x 1"
4. Enclosure
5. Washer A6.4
6. M6 Lock Nut

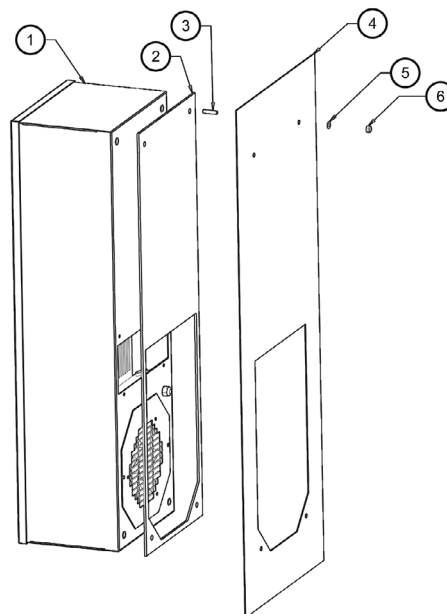

10. Cutout Dimensions

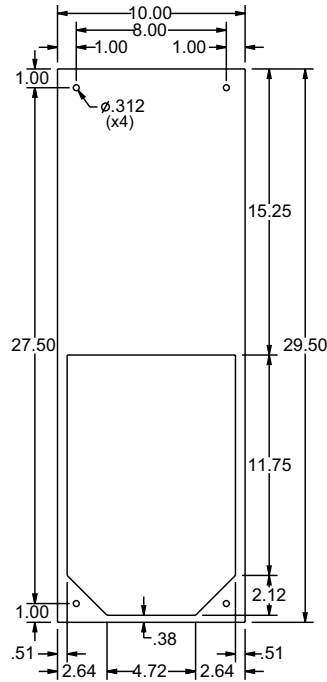

11. Dimensions (H x W x D)

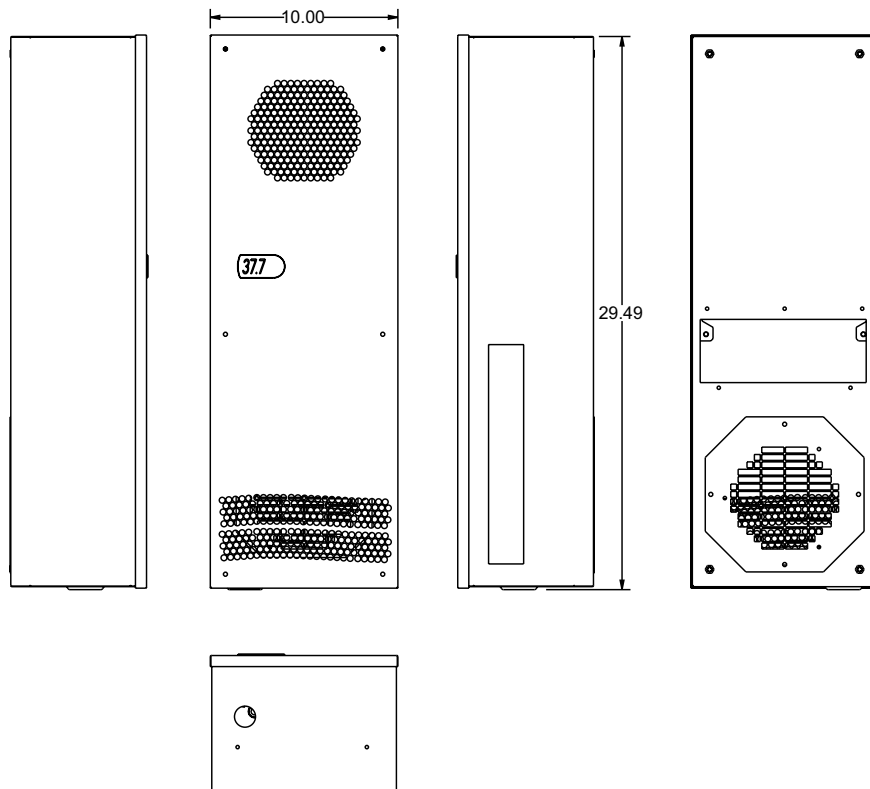
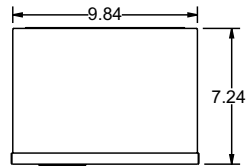

12. Electrical Connection

Door Switch

The unit can be switched on and off via a door contact switch. When delivered the door contact terminals are bridged on the female connector. To connect the door contact switch, remove the bridge and connect door contact switch. The contact must be closed when the cabinet door is closed.

13. Controller Programming

The cooling unit is intended to be used as a complementary accessory to larger industrial equipment. The unit is used where heat needs to be dissipated from electrical control cabinets or similar enclosures in order to protect heat sensitive components. It is not intended for household use. The unit has two completely separate air circuits which ensure that the clean cabinet air does not come into contact with the ambient air which may well be dirty or polluted. Enclosure cooling units can dissipate large quantities of heat from sealed enclosures such as electrical enclosures into the ambient air and at the same time reduce the cabinet internal temperature to below that of the ambient air.



The unit can function without problems in extreme ambient conditions (e.g. dusty and oily air) with a standard operating temperature ranging between +10°C and +55°C. Units can be ordered with an additional electrical cabinet heater. For the cooling capacities and environmental ratings please refer to the type plate data.

Controller



The display shows the temperature in the range of -50°C to +150°C (-58°F to +302°F). The temperature is displayed with resolution of tenths between -19.9°C and +99.9°C (-3.8°F to +211.8°F). During programming, it shows the codes and values of the parameters. The display also shows icons according to occurring events.

Display icons

Icon	Function	Description
1	Compressor relay active	
2	Alarm relay active	Flashes when activation is delayed or inhibited by protection times, external disabling, or other procedures in progress
3	Heater relay active	
4	Ambient blower relay active	
	Alarm	Flashes when alarms are active
	Heating mode	Signals operation of unit in heating mode
	Cooling mode in progress	Activated only by manual procedure

Programming

The operating parameters can be modified using the front keypad. Access differs depending on the type of parameter. Access to configuration parameters is protected by a password that prevents unwanted modifications or access by unauthorised persons.

Setting cooling set point, St1:

1. Press "SET" and display should show St1 and then the pre-set value of St1. (default: +35°C / +95°F)
2. Reach the desired value by using ▲ or ▼.
3. Press "SET" again to save the new value of St1.

Setting heating set point, St2 (only for units supplied with internal heater):

1. Press "SET" twice slowly and display should show St2 and then the pre-set value of St2. (default: +5°C / +41°F)
2. Reach the desired value by using ▲ or ▼.
3. Press "SET" again to save the new value of St2.

Setting temperature units ($^{\circ}\text{C}$ / $^{\circ}\text{F}$), low temperature alarm and high temperature alarm:



1. Press “PRG” button for 5 seconds to reach the modifiable parameter list.
2. Use ▲ or ▼ to reach the desired parameter:
 - C18 for temperature unit of measure
 - $^{\circ}\text{C}$ = 0
 - $^{\circ}\text{F}$ = 1
 - P25 for low temperature alarm threshold (default -10°C / $+14^{\circ}\text{F}$)
 - P26 for high temperature alarm threshold (default $+55^{\circ}\text{C}$ / $+131^{\circ}\text{F}$)
3. Press “SET” on the desired parameter to display the current value.
4. Use ▲ or ▼ to reach the desired value.
5. Pressing “SET” temporarily saves the new value and returns to the parameters list.
6. Repeat steps 2-5 to set other parameters.
7. Press “PRG” for 5 seconds to permanently save the new values.

Test Function

Different test functions can be used depending on the combination of keys pressed. Such tests run for the duration of 4 minutes.

- “SET+▲” tests Compressor and Ambient Blower relays.
- “SET+▼” tests Alarms and Heater relays

14. Wiring Diagram

- IB Internal Blower
- EB External Blower
- C Controller
- T Transformer
- CC 7-Core Cable
- AR Alarm Relay
- X3 Transformer Connector
- X4 Electrical Supply Connections
- 1 L1 - 120V
- 2 Neutral/N - 120V
- 3 Earth/Ground
- 4 —
- 5 P1 High Temp Alarm Contact
- 6 P2 High Temp Alarm Contact
- 7 T1 Door Switch Contact
- 8 T2 Door Switch Contact

Notes:

- #1 The Capacitor and BN Wire are not present in the SCE-HE08W120V
- #2 The Capacitor and BN Wire are not present in the SCE-HE08W120V

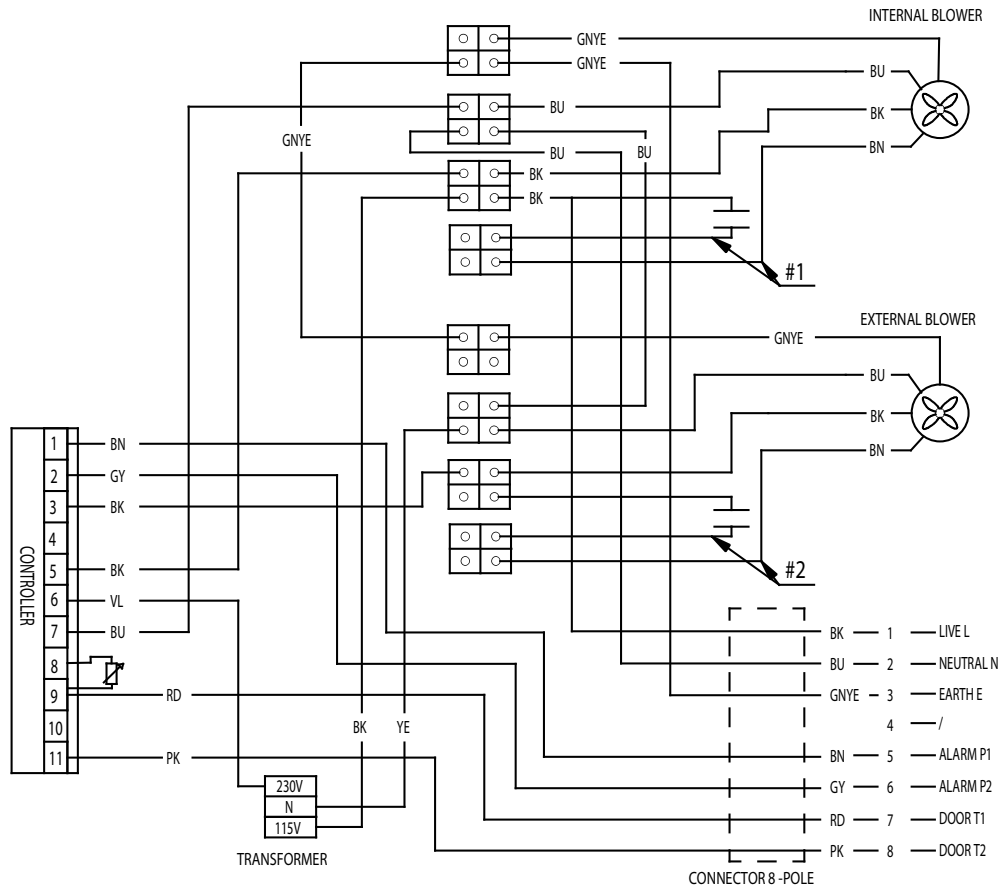

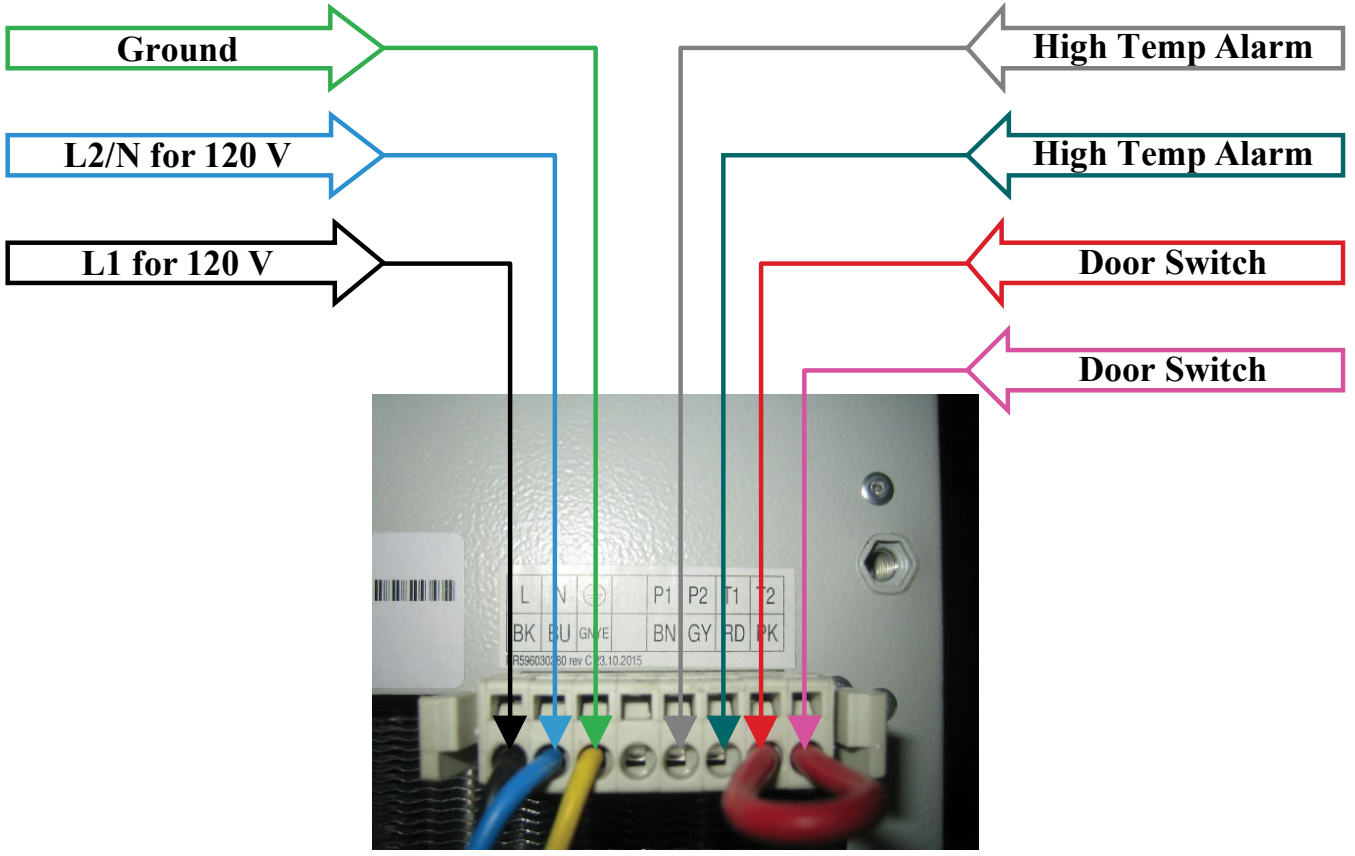

15. Taking Into Operation

As described in the “Technical Information” section, the unit is controlled in relation to the cabinet internal temperature. The required cabinet temperature can be set on the potentiometer on the controller. The temperature adjustment range is between 32°F (left-hand stop) and 140°F (right-hand stop). The thermostat is pre-set at 95°F.

To adjust the cabinet internal temperature, proceed as follows:

- Remove the MCB access plate on the front of the unit
- Using a screw driver, turn the adjustment wheel on the potentiometer “TEMP” slightly to the right (higher) or to the left (lower)
- Please note that the setting for the alarm signal should be at least 41 - 50°F higher than the setting for the cabinet internal temperature

Check that the new adjustment meets the necessary requirements. If necessary, repeat the procedure. Inspect and, if necessary, replace the MCB Access plate sealing tape.

16. Repair

Failure	Condition	Cause	Solution
Unit Does Not Cool	Internal fan does not work	Power not connected.	Verify power supply
	Internal fan works, external fan does not work	Enclosure temperature is below setting temperature (St)	Verify values of parameter "St"
		Door switch contact is open	Verify door switch
		Controller does not work	Replace controller
	Internal fan works, external fan does not work. Display shows alternating "OFF" and temperature	The sequence of the phases inside the power supply connector is incorrect	Change phases inside power supply connector
	External fan does not work	External fan needs to be replaced	Replace external fan
Enclosure Overheating	Fans (external and internal) work all the time	Unit cooling undersized	Enclosure needs a bigger cooling unit
Excessive Condensate	Door enclosure open	Ambient air gets into the enclosure	Ensure door is closed, add a door switch and connect it to controller
	Door enclosure closed	Enclosure IP degree minimum IP54	Seal openings on enclosure
		Damaged/misplaced sealing strip	Repair strip accordingly

17. Maintenance & Cleaning



Danger from Electrical Voltage

Maintenance and cleaning must be carried out by specialists (electricians). The personnel must ensure that for the duration of this work, the unit and the cabinet are disconnected from the electrical supply and protected against unauthorized reactivation.



Danger Through Incorrect Work on the Unit

The instructions in the cabinet manufacturer's manual must be adhered to!



Damage to the Unit Through Maintenance and Repair

Maintenance and repair must be carried out by the manufacturer or another specialist.

Fan Replacement

The rated life expectancy of the fan is L10 = 30,000 hours under normal operating conditions.

To replace the internal or external fan, please proceed with the following:

- Remove the internal access panel by unscrewing the 10 fixing screws
- Disconnect the blower cables from the connectors
- Unscrew the four screws fixing the blower bracket to the cabinet
- Unscrew the fan from the bracket
- Re-assemble with the new blower in reverse order

Make sure that the blower cable length is the same as the one on the fan removed to ensure that the cable does not come in contact with the blower while in operation. Make sure that the correct polarity is maintained (refer to circuit diagram). Inspect and, if necessary, replace the internal access panel sealing tape.

18. Transportation & Storage



Malfunction Due to Transport Damage

On delivery the carton containing the unit must be examined for signs of transport damage. Any transport damage to the carton could indicate that the unit itself has been damaged in transit, which in the worst case could mean that the unit will not function.

Storage Conditions

The unit can only be stored in locations which meet the following conditions:

Temperature Range: 104°F to 158°F

Relative Humidity (at 77°F): Max 95%

Returning the Unit



Damage to the Unit Through Incorrect Transport

To avoid transport damage the unit should be returned in the original packaging or in a packing case and must be strapped to a pallet!

If the unit cannot be returned in the original packaging, please ensure that:

- A space of at least 30 mm. must be maintained at all points between the unit and the external packaging
- The unit must be firmly fixed in the packaging
- The unit must be protected sufficiently by shock absorbing padding (hard foam corner pieces, strips, or cardboard corner pieces)

19. Parts Supplied

1 x Heat Exchanger

1 x Instruction Manual with technical information

1 x EC Declaration

1 x Installation pack containing:

4 x Slotted Studs M6 x 25

4 x Washers A6.4 DIN 125

4 x Lock Nuts M6 DIN 985

1 x Tight Tape

1 x Drain Connector

1 x O-ring

Saginaw Control and Engineering

95 Midland Road

Saginaw, MI 48638-5770

Phone: (989) 799-6871

Fax: (989) 799-4524

sce@saginawcontrol.com

20. Warranty / Limits of Liability

All goods manufactured by SCE shall be warranted to be free of defects in material or workmanship for a period of two years from the date of shipment. Should the product be proven to SCE to be defective, we shall option to repair or replace the product. At no time will SCE reimburse purchaser for unauthorized rework on any product.

Air Conditioners & Heat Exchangers are warranted on parts and service for a period of two years from the date of shipment by Saginaw Control and subject to the following conditions and exclusions:

All Goods must be installed and operated according to the following specifications: Maximum voltage variation no greater than plus or minus 10% of nominal rating; Maximum frequency variation no greater than plus or minus 3 Hz. from nominal rating; Must not exceed minimum and maximum rated temperatures; Must not exceed (BTU/Hr) rating; Filters must be cleaned regularly; Must be installed and grounded in accordance with all relevant electrical and safety codes, as well as the National Electric Code and OSHA rules and regulations; Must be installed in a stationery application, free of vibration.

Our warranty does not warranty product that has been modified, subjected to abuse, negligence in operation or maintenance, or if product is used in a manner that exceeds its designed capabilities and rating.

Warranty related claims will be returned to the factory for evaluation and final disposition of the claim, any replacement parts will be invoiced at standard pricing and credit issued for the returned product. If the product has been found to have been modified, subjected to abuse, negligence in operation or maintenance, or if product has been used in a manner that exceeds its designed capabilities and rating, credit may be reduced, denied or additional cost may be assessed and passed on to the purchaser, such as return freight.