

Selection diagram

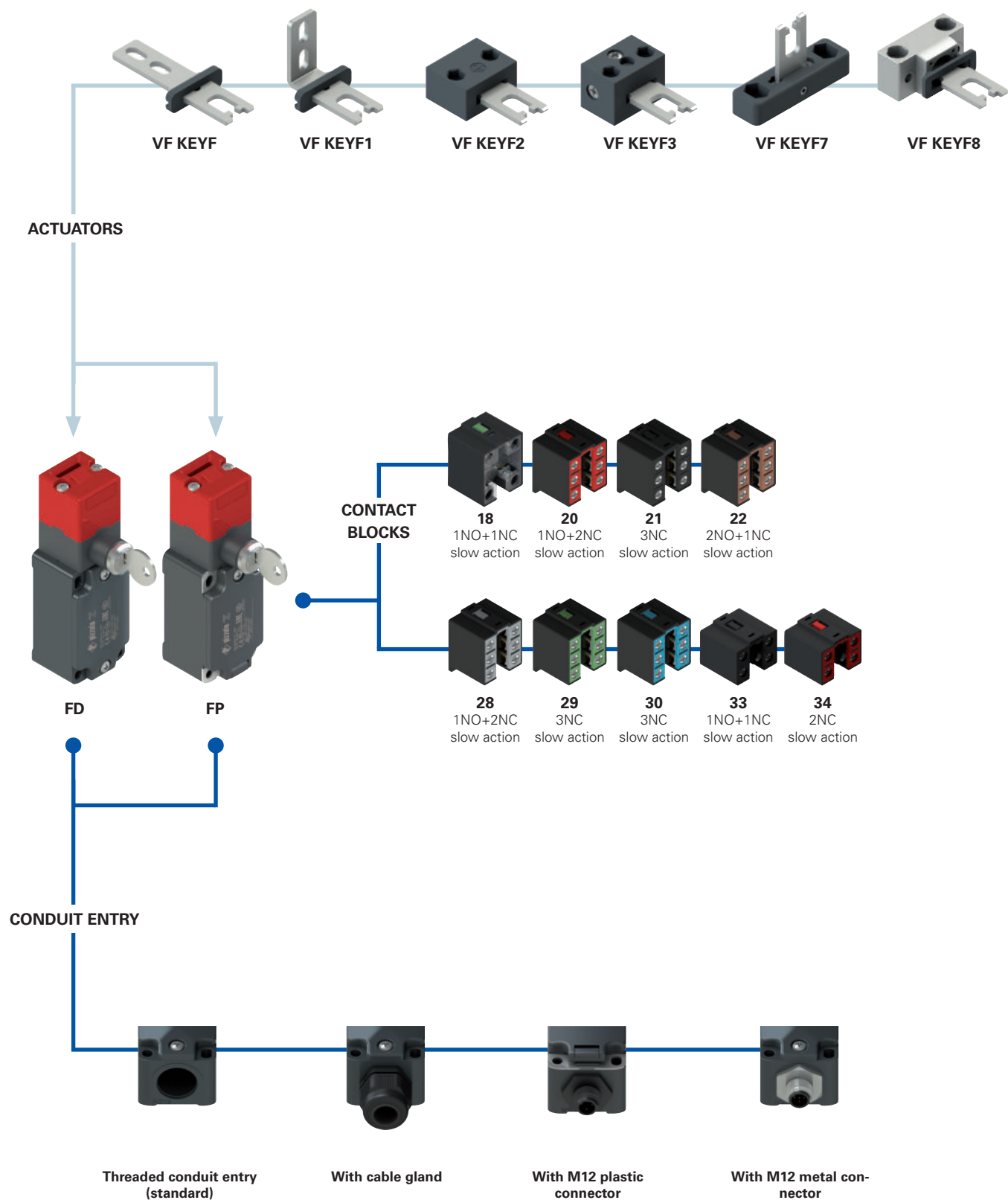



Code structure

Attention! The feasibility of a code number does not mean the effective availability of a product. Please contact our sales office.

article
options
options
FD 1899-F1GM2K50T6V200

Housing	
FD	metal, one conduit entry
FP	technopolymer, one conduit entry

Lock key coding	
	one standard key coding (371)
V200	up to 8 different key codings

Contact blocks		
	Contacts activated by the lock	Contacts activated by actuator extraction
18	1NO+1NC	
20	1NO+2NC	
21	3NC	
22	2NO+1NC	
28	1NO+1NC	1NC
29	2NC	1NC
30	1NC	2NC
33	1NO+1NC	
34	2NC	

Ambient temperature	
	-25°C ... +80°C (standard)
T6	-40°C ... +80°C

Pre-installed cable glands or connectors	
	no cable gland or connector (standard)
K23	cable gland for cables Ø 6 ... 12 mm
...
K50	M12 metal connector, 5-pole
...

For the complete list of possible combinations please contact our technical department.

Actuators	
	without actuator (standard)
F	straight actuator VF KEYF
F1	angled actuator VF KEYF1
F2	jointed actuator VF KEYF2
F3	jointed actuator adjustable in two directions VF KEYF3
F7	jointed actuator adjustable in one direction VF KEYF7
F8	universal actuator VF KEYF8

Threaded conduit entry	
M2	M20x1.5 (standard)
	PG 13.5

Contact type	
	silver contacts (standard)
G	silver contacts with 1 µm gold coating
G1	silver contacts, 2.5 µm gold coating (not for contact blocks 20, 21, 22, 28, 29, 30, 33, 34)

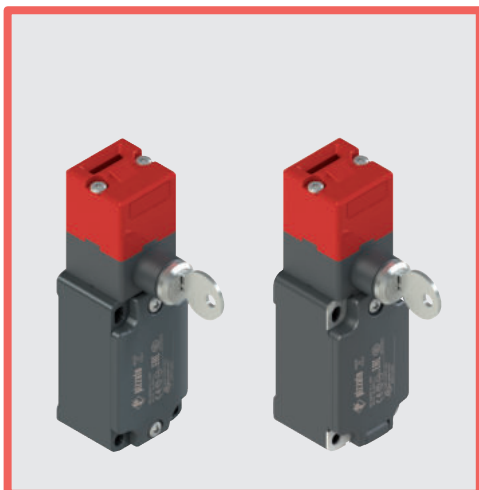

Main features

- Metal housing or technopolymer housing, one conduit entry
- Protection degree IP67
- 9 contact blocks available
- 6 stainless steel actuators available
- Versions with assembled M12 connector
- Versions with gold-plated silver contacts
- Strong actuator locking (1000 N)
- Release of the actuator by key

Quality marks:



IMQ approval:	EG605
UL approval:	E131787
CCC approval:	2007010305230000
EAC approval:	RU C-IT.YT03.B.00035/19

Technical data

Housing

FP series housing made of glass fibre reinforced technopolymer, self-extinguishing, shock-proof and with double insulation: 
 FD series: metal housing, baked powder coating.
 Metal head, baked epoxy powder coating.
 One threaded conduit entry: M20x1.5 (standard)
 Protection degree: IP67 acc. to EN 60529 with cable gland of equal or higher protection degree

General data

SIL (SIL CL) up to:	SIL 3 acc. to EN 62061
Performance Level (PL) up to:	PL e acc. to EN ISO 13849-1
Interlock with mechanical lock, coded:	type 2 acc. to EN ISO 14119
Coding level:	low acc. to EN ISO 14119
Safety parameters:	
B_{10D} :	1,000,000 for NC contacts
Mission time:	20 years
Ambient temperature:	-25°C ... +80°C (standard) -40°C ... +80°C (T6 option)
Max. actuation frequency:	3600 operating cycles/hour
Mechanical endurance:	500,000 operating cycles
Max. actuation speed:	0.5 m/s
Min. actuation speed:	1 mm/s
Maximum force before breakage F_{1max} :	1000 N acc. to EN ISO 14119
Max. holding force F_{Zh} :	770 N acc. to EN ISO 14119
Max. clearance of the actuator:	4.5 mm
Actuator extraction force:	30 N
Tightening torques for installation:	see page 339
Wire cross-sections and wire stripping lengths:	see page 357

In compliance with standards:

IEC 60947-5-1, IEC 60947-1, IEC 60204-1, EN ISO 14119, EN ISO 12100, IEC 60529, EN 50581, BG-GS-ET-15, UL 508, CSA 22.2 No.14.

Approvals:

EN 60947-5-1, UL 508, CSA 22.2 No.14, GB/T14048.5-2017.

Compliance with the requirements of:

Machinery Directive 2006/42/EC, EMC Directive 2014/30/EU, RoHS Directive 2011/65/EU.

Positive contact opening in conformity with standards:

IEC 60947-5-1, EN 60947-5-1.

 If not expressly indicated in this chapter, for correct installation and utilization of all articles see the instructions given on pages 337 to 350.

Electrical data

Utilization category

	Electrical data	Utilization category
without connector	Thermal current (I_{th}): 10 A Rated insulation voltage (U_i): 500 Vac 600 Vdc 400 Vac 500 Vdc (contact blocks 20, 21, 22, 28, 29, 30, 33, 34) Rated impulse withstand voltage (U_{imp}): 6 kV 4 kV (contact blocks 20, 21, 22, 28, 29, 30, 33, 34) Conditional short circuit current: 1000 A acc. to EN 60947-5-1 Protection against short circuits: type aM fuse 10 A 500 V Pollution degree: 3	Alternating current: AC15 (50±60 Hz) U_e (V) 250 400 500 I_e (A) 6 4 1 Direct current: DC13 U_e (V) 24 125 250 I_e (A) 3 0.55 0.3
with M12 connector, 4 and 5-pole	Thermal current (I_{th}): 4 A Rated insulation voltage (U_i): 250 Vac 300 Vdc Protection against short circuits: type gG fuse 4 A 500 V Pollution degree: 3	Alternating current: AC15 (50±60 Hz) U_e (V) 24 120 250 I_e (A) 4 4 4 Direct current: DC13 U_e (V) 24 125 250 I_e (A) 3 0.55 0.3
with M12 connector, 8-pole	Thermal current (I_{th}): 2 A Rated insulation voltage (U_i): 30 Vac 36 Vdc Protection against short circuits: type gG fuse 2 A 500 V Pollution degree: 3	Alternating current: AC15 (50±60 Hz) U_e (V) 24 I_e (A) 2 Direct current: DC13 U_e (V) 24 I_e (A) 2



Features approved by IMQ

Rated insulation voltage (U _i):	500 Vac 400 Vac (for contact blocks 20, 21, 22, 33, 34)
Conventional free air thermal current (I _{th}):	10 A
Protection against short circuits:	type aM fuse 10 A 500 V
Rated impulse withstand voltage (U _{imp}):	6 kV 4 kV (for contact blocks 20, 21, 22, 33, 34)
Protection degree of the housing:	IP67
MV terminals (screw terminals)	
Pollution degree:	3
Utilization category:	AC15
Operating voltage (U _e):	400 Vac (50 Hz)
Operating current (I _e):	3 A
Forms of the contact element:	Zb, Y+Y, Y+Y+X, Y+Y+Y, Y+X+X
Positive opening contacts on contact blocks	18, 20, 21, 22, 28, 29, 30
In compliance with standards:	EN 60947-1, EN 60947-5-1, fundamental requirements of the Low Voltage Directive 2014/35/EU.

Please contact our technical department for the list of approved products.

Features approved by UL

Electrical Ratings:	Q300 pilot duty (69 VA, 125-250 V dc) A600 pilot duty (720 VA, 120-600 V ac)
Environmental Ratings:	Types 1, 4X, 12, 13
Use 60 or 75 °C copper (Cu) conductor and wire size range 12, 14 AWG, stranded or solid. The terminal tightening torque of 7.1 lb in (0.8 Nm).	
For FP series: the hub is to be connected to the conduit before the hub is connected to the enclosure.	

Please contact our technical department for the list of approved products.

Description



This type of switches is applied on fences or guards where entrance is allowed to authorized personnel only. They have been designed to control large protected areas where operators may physically enter. Supplied with a strong lock, the actuator can be removed from the head only after a complete rotation (180°) of the locking key. The electrical contacts are switched as the key is turned; the actuator is released only after the NC contacts have been positively opened. Contacts activated by the lock are reset to the initial position only with inserted actuator and with the key in the locking position. It is impossible to rotate the key when the key locking device is unlocked and the actuator is removed (C state). These switches are considered interlocks with guard locking in accordance with ISO 14119, and the product is marked on the side with the symbol shown.



Head and release devices with variable orientation

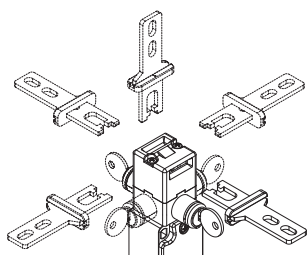

The head can be quickly turned to each of the four sides of the switch by unfastening the two fastening screws.

The auxiliary key release device can be rotated in 90° steps as well. This enables the switch to assume 32 different configurations.

Adjustment range

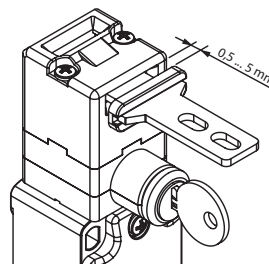

The actuation head of this switch features a wide range of travel. In this way the guard can oscillate along the direction of insertion (4.5 mm) without causing unwanted machine shutdowns. This wide range of travel is available in all actuators in order to ensure maximum device reliability.

Protection degree IP67

IP67 These devices are designed to be used in the toughest environmental conditions and they pass the IP67 immersion test acc. to EN 60529. They can therefore be used in all environments where maximum protection degree of the housing is required.

Contact block



Contact blocks with captive screws, finger protection, twin bridge contacts and double interruption for higher contact reliability.

Holding force of the unlocked actuator

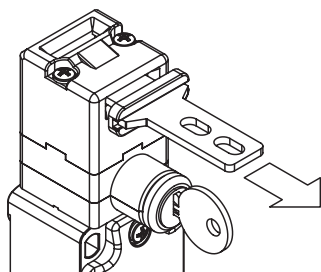

The inside of each switch features a device which holds the actuator in its closed position. Ideal for all those applications where several guards are unlocked simultaneously, but only one is actually opened. The device keeps all the unlocked guards in their position with a retaining force of approx. 30 N, stopping any vibrations or gusts of wind from opening them.

Extended temperature range

-40°C

These devices are also available in a special version suitable for an ambient operating temperature range from -40°C up to +80°C.

They can therefore be used for applications in cold stores, sterilisers and other equipment with low temperature environments. The special materials used to produce these versions retain their characteristics even under these conditions, thereby expanding the installation possibilities.

Laser engraving



All devices are marked using a dedicated indelible laser system. These engravings are therefore suitable for extreme environments too. Thanks to this system that does not use labels, the loss of plate data is prevented and a greater resistance of the marking is achieved over time.

Safety screws for actuators

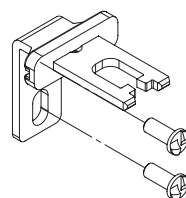

As required by ISO 14119, the actuator must be fixed immovably to the guard frame. Pan head safety screws with one-way fitting are available for this purpose. With this screw type, the actuators cannot be removed or tampered by using common tools. See accessories on page 332.

Operation

The switch is fastened to the machine body (A), while the stainless steel actuator is fastened to the guard (B). Once installed, the switch will firmly lock the actuator. To remove the actuator, the lock must be unlocked by turning the key (C). When the actuator is removed, the key cannot be put into the initial position anymore. The example shows how the contacts of the lock and actuator are switched and how the switch can be installed within the machine in such a way that only the release device is visible from the outside.

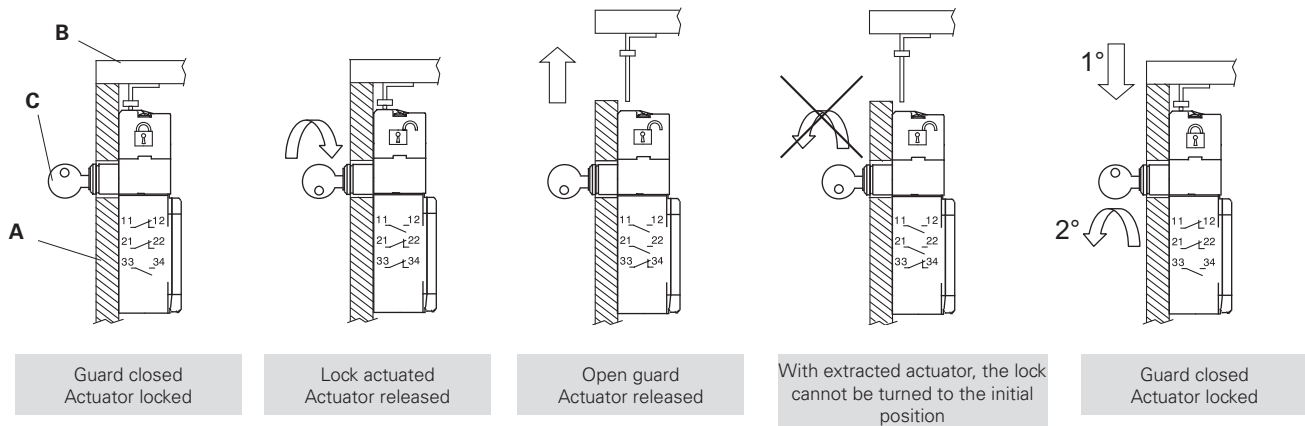

Operating phases

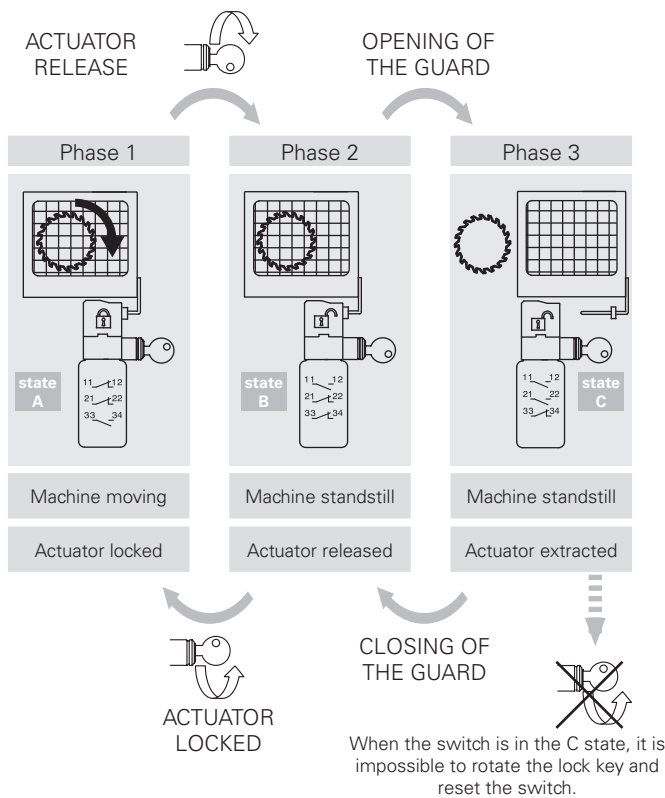

Contact positions related to switch states

Operating state	state A	state B	state C
Actuator	Inserted and locked	Inserted and released	Extracted
Lock	Closed	Open	Open

Contact blocks	state A	state B	state C
FD 1899 1NO+1NC controlled by the lock			
FD 2099 1NO+2NC controlled by the lock			
FD 2199 3NC controlled by the lock			
FD 2299 2NO+1NC controlled by the lock			
FD 2899 1NO+1NC controlled by the lock 1NC controlled by the actuator			
FD 2999 2NC controlled by the lock 1NC controlled by the actuator			
FD 3099 1NC controlled by the lock 2NC controlled by the actuator			

The key can be extracted from the lock with locked or released actuator.

Limits of use

Do not use where dust and dirt may penetrate in any way into the head and deposit there. Especially not where powder, shavings, concrete or chemicals are sprayed. Adhere to the ISO 14119 requirements regarding low level of coding for interlocks. Do not use in environments with presence of explosive or flammable gas. In these case use ATEX products (see dedicated Pizzato catalogue). Attention! These switches alone are not suitable for applications where operators may physically enter the dangerous area, because an eventual closing of the door behind them could restart the machine operation. In these cases the actuator entry locking device VF KB1 shown on page 106 must be used.



Contact type:	Technopolymer housing		Metal housing	
	Without actuator, supplied with two keys		Without actuator, supplied with two keys	
L = slow action				
Contact blocks				
18	L	FP 1899-M2 1NO+1NC	FD 1899-M2 1NO+1NC	
20	L	FP 2099-M2 1NO+2NC	FD 2099-M2 1NO+2NC	
21	L	FP 2199-M2 3NC	FD 2199-M2 3NC	
22	L	FP 2299-M2 2NO+1NC	FD 2299-M2 2NO+1NC	
28	L	FP 2899-M2 1NO+2NC	FD 2899-M2 1NO+2NC	
29	L	FP 2999-M2 3NC	FD 2999-M2 3NC	
30	L	FP 3099-M2 3NC	FD 3099-M2 3NC	
33	L	FP 3399-M2 1NO+1NC	FD 3399-M2 1NO+1NC	
34	L	FP 3499-M2 2NC	FD 3499-M2 2NC	
Actuating force		30 N (40 N)	30 N (40 N)	

Legend: With positive opening according to EN 60947-5-1, interlock with lock monitoring acc. to EN ISO 14119

How to read travel diagrams

All values in the diagrams are in mm or in degrees

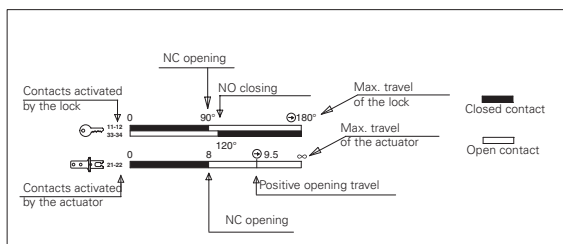

IMPORTANT:

The state of the NC contact () refers to the switch with inserted actuator and locked lock. In safety applications, actuate the switch **at least up to the positive opening travel** shown in the travel diagrams with symbol . Actuate the switch **at least with the positive opening force**, reported in brackets below each article, next to the actuating force value.

Stainless steel actuators

IMPORTANT: These actuators can be used only with items of the FD, FP, FL, FC, and FS series (e.g. FD 1899-M2).
Low level of coding acc. to EN ISO 14119.

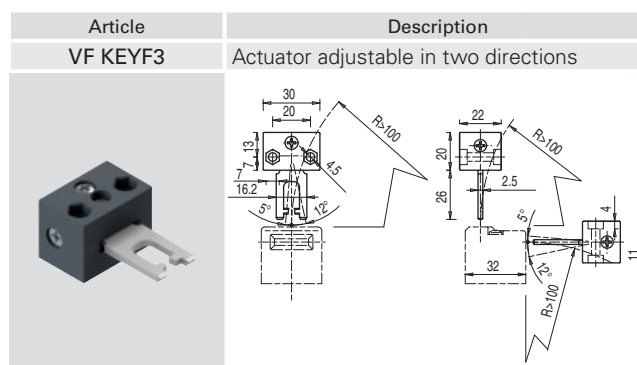
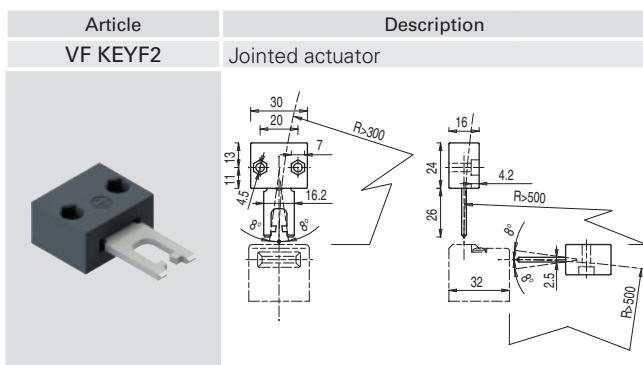
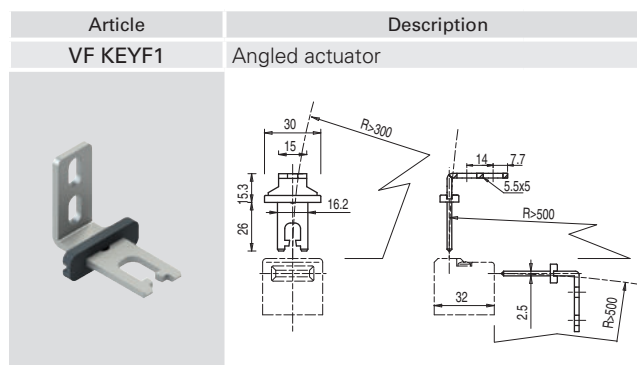
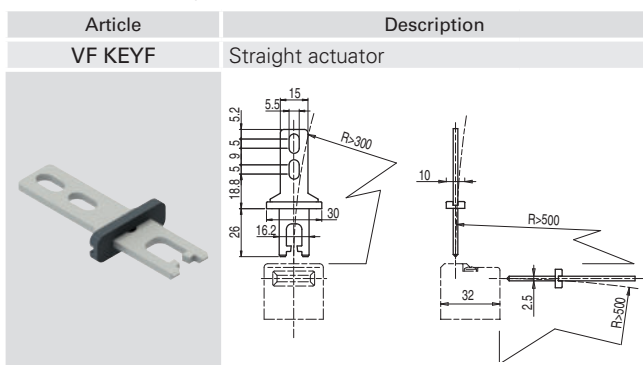

The actuator can flex in four directions for applications where the guard alignment is not precise.

Actuator adjustable in two directions for guards with reduced dimensions.

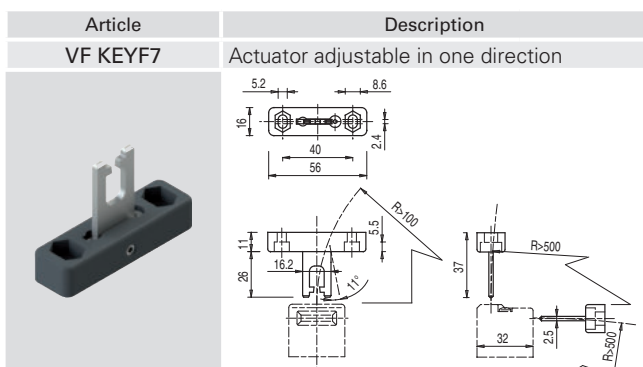

Actuator adjustable in one direction for guards with reduced dimensions.



Universal actuator VF KEYF8

IMPORTANT: These actuators can be used only with items of the FD, FP, FL, FC, and FS series (e.g. FD 1899-M2).
Low level of coding acc. to EN ISO 14119.

Article	Description
VF KEYF8	Universal actuator

Jointed actuator for guards with poor alignment, adjustable in two dimensions for small doors; can be mounted in various positions. The metal fixing body has two pairs of bore holes; it is provided for rotating the working plane of the actuator by 90°.

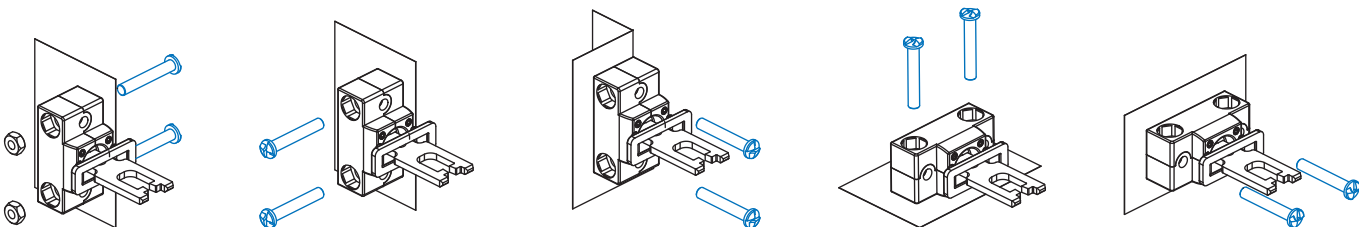
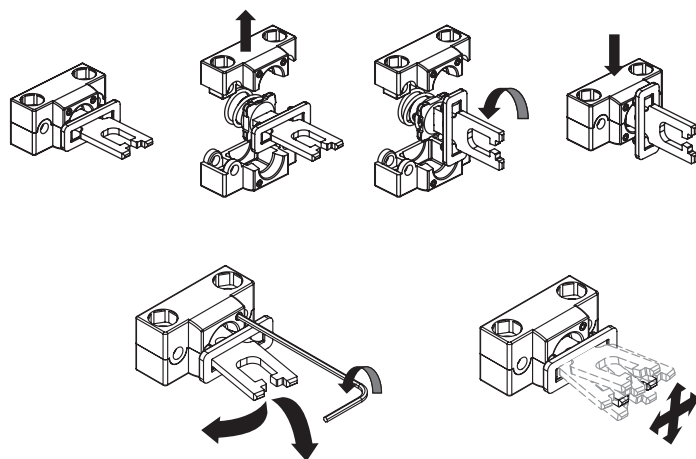

Accessories

Article	Description
VF KB1	Lock out device

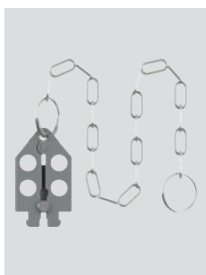

Padlockable lock out device to prevent the actuator entry and the accidental closing of the door behind operators while they are in the danger area.
Hole diameter for padlocks: 9 mm.



Article	Description
VF KLA371	Set of two locking keys

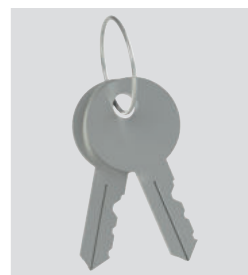

Extra copy of the locking keys to be purchased if further keys are needed (standard supply: 2 units). The keys of all switches have the same code. Other codes on request.