

Description



These switches are used on machines where the hazardous conditions remain for a while, even after the machines have been switched off, for example because of mechanical inertia of pulleys, saw disks, parts under pressure or with high temperatures. Thus, the switches can also be used if individual guards are only to be opened under certain conditions.

Versions with mode 1 and 3 (safety outputs active when guard closed and locked) are interlocks with guard locking acc. to ISO 14119; the product is labelled with the symbol shown.



Maximum safety with a single device

PL e + SIL 3

The NG series switches are constructed with redundant electronics. As a result, the maximum PL e and SIL 3 safety levels can still be achieved through the use of a single device on a guard. This avoids expensive wiring in the field and allows faster installation. Inside the control cabinet, the two electronic safety outputs must be connected to a safety module with OSSD inputs or to a safety PLC.

Series connection of several switches

PL e + SIL 3

One of the most important features of the NG series is the possibility of connecting up to 32 sensors in series, while still maintaining the maximum safety levels PL e laid down in EN 13849-1 and SIL 3 acc. to EN 62061.

This connection type is permissible in safety systems which have a safety module at the end of the chain that monitors the outputs of the last NG switch. The fact that the PL e safety level can be maintained even with 32 sensors connected in series demonstrates the extremely secure structure of each single device.

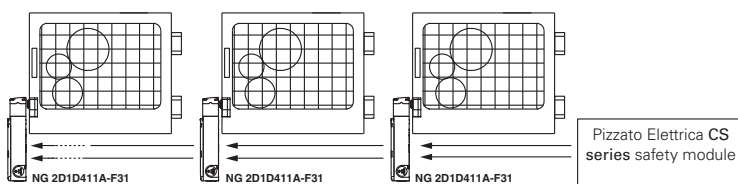

Series connection with other devices

PL e + SIL 3

The NG series features two safety inputs and two safety outputs, which can be connected in series with other Pizzato Elettrica safety devices. This option allows the creation of safety chains containing various devices. For example, stainless steel safety hinges (HX BEE1 series), transponder sensors (ST series) and door lock sensors (NG series) can be connected in series while still maintaining the maximum PL e and SIL 3 safety levels.

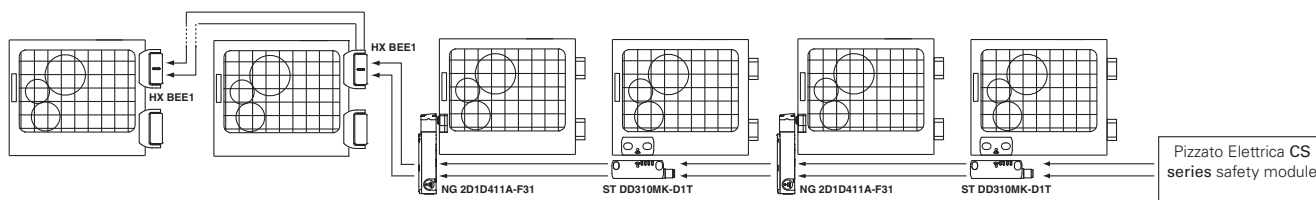

RFID actuators with high coding level



The NG series is provided with an electronic system based on RFID technology to detect the actuator. This allows to provide each actuator with different coding and makes it impossible to tamper with a device by using another actuator of the same series. Millions of different coding combinations are possible for the actuators. They are therefore classified as high level coded actuators, according to EN ISO 14119.

The NG series is provided with an electronic system based on RFID technology to detect the actuator. This allows to provide each actuator with different coding and makes it impossible to tamper with a device by using another actuator of the same series. Millions of different coding combinations are possible for the actuators. They are therefore classified as high level coded actuators, according to EN ISO 14119.

Holding force of the locked actuator

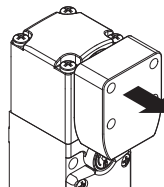

9750 N

The strong interlocking system guarantees a maximum actuator holding force of $F_{Tmax} = 9750 \text{ N}$. This is one of the highest values currently available on the market today, making this device suitable for heavy-duty applications.

Dustproof

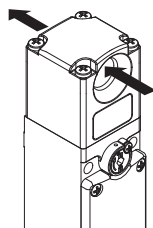

The switch is provided with a through hole for inserting the actuator. Thanks to this unique feature, any dust that enters the actuator hole can always come out on the opposite side instead of remaining inside. Moreover, the lock pin is provided with a diaphragm seal, making the system suitable for critical environments with a high level of dust.

Integrated control devices

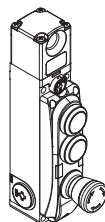

The switch is also available with elevated cover. Control devices such as buttons, emergency buttons, indicator lights or selectors can thereby be attached directly to the switch together with corresponding contact blocks.

The result is a compact solution with direct access to control devices without needing to install them separately on the switch panel or in their own housing. The devices can be illuminated and, thanks to the PUSH-IN spring-operated connections, wiring is quick and intuitive.

Centring

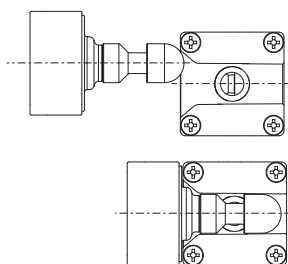

The switch is provided with a wide centring inlet for the actuator pin. This solution makes it easier to align the actuator and the opening hole on the head during installation. Moreover, this solution drastically reduces the probability of a collision between the switch and the actuator, making it possible to install the device even on inaccurately closing doors.

Push-in spring-operated connections

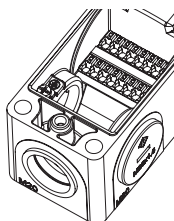

The switch is provided with a PUSH-IN type spring-operated connection system on the inside. This technology allows wiring to be performed quickly and easily, as the wire just needs to be inserted into the appropriate hole in order to establish the electrical connection and automatically secure the wire. This operation can be performed with rigid or flexible wires with a crimped wire-end sleeve and requires no tools. Release is obtained by pressing the appropriate wire-releasing button.



Six LEDs for immediate diagnosis



As the LEDs have been designed for quick immediate diagnosis, the status of each input and output is highlighted by one specific LED. This makes it possible to quickly identify the interruption points in the safety chain, which device is released, which door is opened and any errors inside the device. All of this at a glance, without needing to decode complex flashing sequences.

Holding force of the unlocked actuator

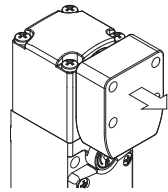

The inside of each switch features a device which holds the actuator in its closed position. Ideal for all those applications where several guards are unlocked simultaneously, but only one is actually opened. The device keeps all the unlocked guards in their position with a retaining force of approx. 30 N, stopping any vibrations or gusts of wind from opening them.

Protection against tampering

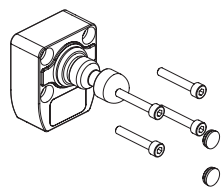

Each actuator of the NG series is supplied with four protection caps. Not only do the caps prevent dirt from accumulating and simplify cleaning, they also block access to the fastening screws of the actuator. As a result, standard screws can be used instead of tamper-proof screws.

Jointed actuator for inaccurately closing guards

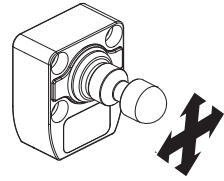

All NG series actuators are articulated, thereby allowing the actuator pin to be safely guided into the switch through the centring hole. As a result, the actuator and switch do not need to be precisely aligned during installation. In addition, the device can thereby be used on guards with a minimum actuation radius of 150 mm without the actuation pin needing to be angled.

Function for protecting against recoil forces

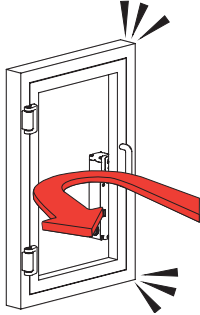

If a guard is closed too quickly or with so much force that the recoil would cause it to open again, a special function in the NG switch prevents locking. This function prevents the immediate locking of the guard if the lock signal is applied. This protects the switch against recoil forces that occur during instantaneous locking. This serves to protect the switch from damage and forces the operator to close the guard more gently.

Head and devices with variable orientation

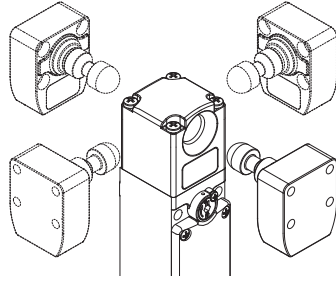

The system can be variably configured by loosening the 4 screws on the head. The key release device and the escape release button can also be rotated and secured independently of one another in steps of 90°. The device can thus assume 16 different configurations.

Key release device and escape release button

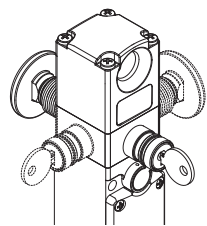

The key release device (auxiliary release) is used to permit unlocking of the actuator only by personnel in possession of the key. The device also functions with no power supply and, once actuated, prevents the guard from being locked.

The escape release button allows actuator release and immediate opening of the guard. Generally used in machines

within which an operator could inadvertently become trapped, it faces towards the machine interior, to allow the operator to exit even in the event of a power failure. The button has two stable states and can be freely extended in length with suitable extensions (see accessories). Both devices can be positioned on the four sides of the switch. As a result, it can be installed both towards the interior and towards the exterior of the machine.

Non-detachable head and release devices

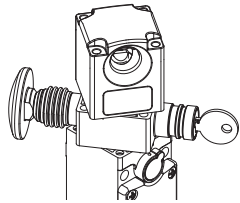

The head and the release device can be rotated but cannot be detached from each other. This makes the switch more secure since the problem of incorrect assembly by the installer cannot occur; in addition, the risk of damage is lower (loss of small parts, penetration of dirt, etc.).

High protection degree

IP69K
IP67

These devices are designed to be used in the toughest environmental conditions and they pass the IP67 immersion test acc. to EN 60529. They can therefore be used in all environments where maximum protection degree of the housing is required. Due to their special design, these devices are suitable for use in equipment subjected to cleaning with high pressure hot water jets. These devices meet the IP69K test requirements according to ISO 20653 (water jets with 100 bar and 80°C).

Three safety output actuation modes

MODE 1
MODE 2
MODE 3

The device is available with 3 different actuation modes for safety outputs:

- mode 1: safety outputs active with inserted and locked actuator, for machines with inertia;
- mode 2: safety outputs active with inserted actuator, for machines without inertia;

- mode 3: a first safety output active with actuator inserted and locked and a second safety output active with actuator inserted, for special applications.

External device monitoring

EDM

On request, the switch can be supplied with EDM function (External Device Monitoring). In this case, the switch itself checks the proper function of the devices connected to the safety outputs. These devices (usually relays or safety contactors) must send a feedback signal to the EDM input, which checks that the received signal is consistent with the state of the safety outputs.

Selection diagram

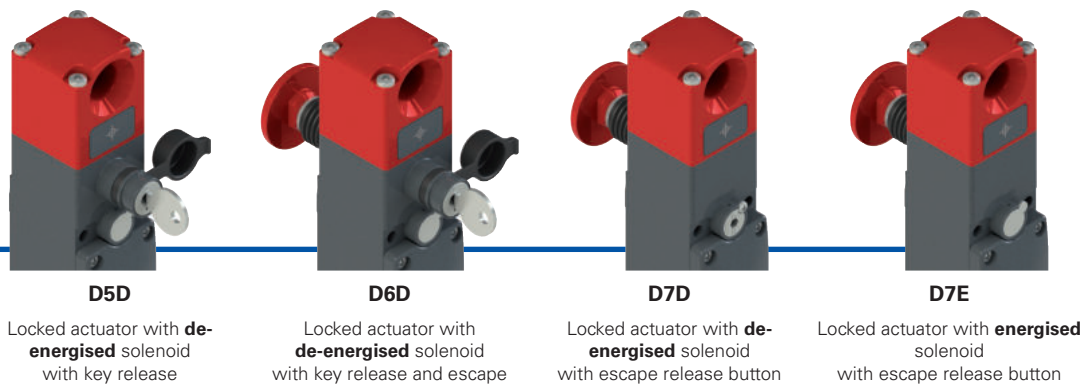

HEAD TYPE AND OPERATING PRINCIPLE

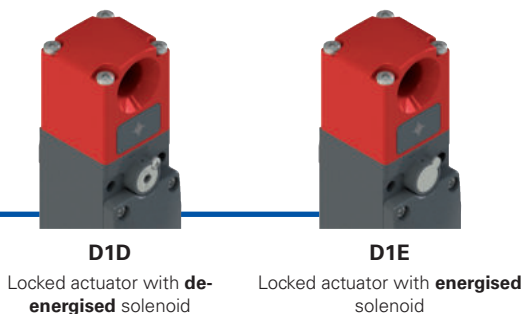

ACTUATORS

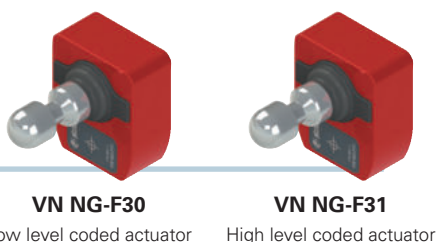

COVER CONFIGURATIONS

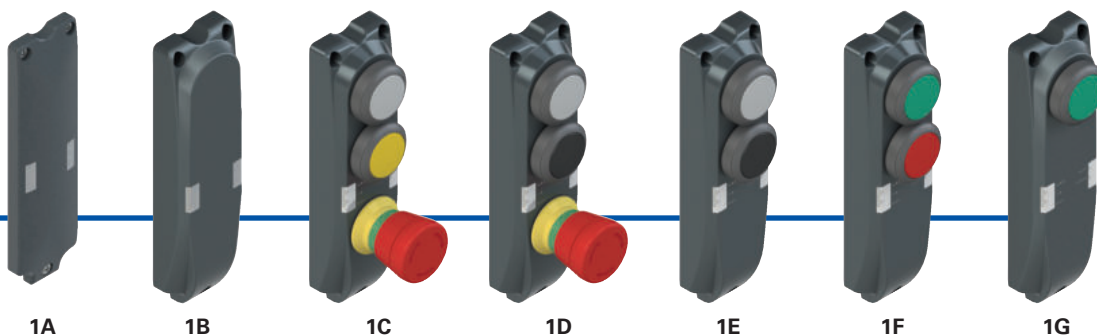

CONDUIT ENTRIES

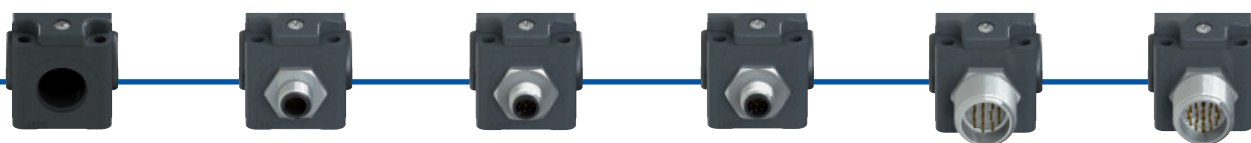

Threaded conduit entry M20

With M12 metal connector

With M12 metal connector for stand-alone connection

With M12 metal connector for series connection with "Y" connectors

With M23 metal connector (clockwise numbering)

With M23 metal connector (clockwise numbering)

K110	12-pole, bottom
K111	12-pole, right
K112	12-pole, left

K953	8-pole, bottom
K954	8-pole, right
K955	8-pole, left

K950	8-pole, bottom
K951	8-pole, right
K952	8-pole, left

K900	12-pole, bottom
K901	12-pole, right
K902	12-pole, left

K601	19-pole, bottom, configuration 1
K602	19-pole, bottom, configuration 2
...

● product options
→ Sold separately as accessory

**Code structure****Attention!** The feasibility of a code number does not mean the effective availability of a product. Please contact our sales office.

article
options

NG 2D1D411A-F31E34K900LP30

Operating principle		Release button length	
D1D	locked actuator with de-energised solenoid		for max. 15 mm wall thickness (standard)
D1E	locked actuator with energised solenoid	LP30	for max. 30 mm wall thickness
D5D	locked actuator with de-energised solenoid. With key release	LP40	for max. 40 mm wall thickness
D6D	locked actuator with de-energised solenoid. With key release and escape release button	LP50	for max. 50 mm wall thickness
D7D	locked actuator with de-energised solenoid. With escape release button	LP60	for max. 60 mm wall thickness
D7E	locked actuator with energised solenoid. With escape release button	...	other wall thicknesses on request

Inputs and outputs		Pre-installed connectors	
3	2 safety inputs IS1, IS2		without connector (standard)
	2 safety outputs OS1, OS2	K110	M12 metal connector, 12-pole, bottom
	1 signalling output O3: actuator inserted	K601	M23 metal connector, 19-pole, bottom, configuration 1
	1 signalling output O4: actuator locked	K900	M23 metal connector, 12-pole, bottom
	1 or IE1/IE2 inputs for solenoid activation	K950	M12 metal connector, 8-pole, bottom, for series connection
1 reset input I3	...	other connectors on request	
Note: Supplied only together with actuator		For the complete list of possible combinations please contact our technical department.	

Actuator extraction force	
	actuator extraction force 30 N (standard)
E34	actuator freely removable

Actuator	
F30	low level coded actuator VN NG-F30 the switch recognises any type F30 actuator
F31	high level coded actuator VN NG-F31 the switch recognises one single type F31 actuator

Cover configurations	
1A	low cover (standard)
1B	raised cover without holes
1C	cover with white button / yellow button / emergency button with rotary release
1D	cover with white button / black button / emergency button with rotary release
1E	cover with white button / black button
1F	cover with green button / red button
1G	cover with green button
...	other configurations on request

Activation of OS outputs	
1	mode 1: safety outputs OS1 and OS2 active with inserted and locked actuator
2	mode 2: safety outputs OS1 and OS2 active with inserted actuator
3	mode 3: safety output OS1 active with inserted and locked actuator, safety output OS2 active with inserted actuator

Code structure for actuator**VN NG-F30**

Actuator	
F30	low level coded actuator the switch recognises any type F30 actuator
F31	high level coded actuator the switch recognises one single type F31 actuator

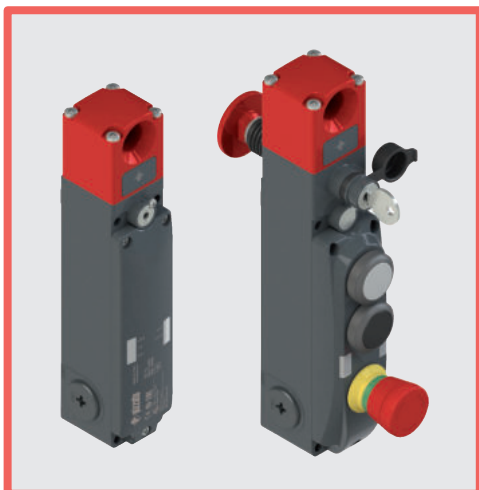

Main features

- Actuation without contact, using RFID technology
- Digitally coded actuator
- Actuator holding force: 9750 N
- SIL 3 and PL e with a single device
- Metal housing, three M20 conduit entries
- Protection degree up to IP67 and IP69K
- PL e also with series connection of up to 32 devices
- Signalling LED

Quality marks:



EC type examination certificate: M6A180475157023

UL approval: E131787

TÜV SÜD approval: Z10 18 04 75157 022

EAC approval: RU C-IT.YT03.B.00035/19

In compliance with standards:

EN ISO 14119, EN 60947-5-3, EN 60947-1, IEC 60204-1, EN 60204-1, EN ISO 12100, IEC 60529, EN 60529, EN 61000-6-2, EN 61000-6-3, BG-GS-ET-19, IEC 61508-1, IEC 61508-2, IEC 61508-3, IEC 61508-4, SN 29500, EN ISO 13849-1, EN ISO 13849-2, EN 62061, EN 61326-1, EN 61326-3-1, EN 61326-3-2, EN 50581, ETSI 301 489-1, ETSI 301 489-3, ETSI 300 330-2, UL 508, CSA 22.2 No. 14

Compliance with the requirements of:

Machinery Directive 2006/42/EC, EMC Directive 2014/30/EC, RED Directive 2014/53/EU, RoHS directive 2011/65/EU, FCC Part 15.

Features approved by UL

Electrical Ratings: 24 Vdc, 0,25 A.

Input supplied by Class 2 source or limited voltage limited energy.

Environmental Ratings: Types 1, 4X, 12, 13 (versions without control devices), Type 1 (versions with control devices).

Features approved by TÜV SÜD

Protection degree: IP67, IP69K
Ambient temperature: -20°C...+50°C
Storage temperature: -40°C...+75°C
PL, category: PL e, cat. 4
SIL: SIL 3 / SIL CL 3

In compliance with standards: 2006/42/EC, EN 60947-1:2007/A2:2014, EN 60947-5-2:2007/A1:2012, EN 60947-5-3:2013, EN ISO 14119:2013, EN 61508-1:2010 (SIL 3), EN 61508-2:2010 (SIL 3), EN 61508-3:2010 (SIL 3), EN 61508-4:2010 (SIL 3), EN 62061:2005/A2:2015 (SIL CL 3), EN ISO 13489-1:2015 (PL e, Cat 4).

Please contact our technical department for the list of approved products.

Technical data

Metal head and housing, baked powder coating.

Three threaded conduit entries:

Protection degree:

M20x1.5

IP67 acc. to EN 60529,

IP69K acc. to ISO 20653

Protection degree with control devices:

IP65 acc. to EN 60529 with cable gland of equal or higher protection degree

General data

Safety parameters	SIL	PL	Cat.	DC	PFH ₀	MTTF ₀
Monitoring function: actuator locked - Mode 1	3	e	4	High	1,15E-09	2968
Monitoring function: actuator present - Mode 2	3	e	4	High	1,15E-09	3946
Monitoring function: actuator locked - Mode 3	2	d	2	High	1,48E-09	2957
Monitoring function: actuator present - Mode 3	2	d	2	High	1,48E-09	3927
Dual-channel control for locking function of the actuator	3	e	4	High	1,51E-10	4011
Single-channel control for locking function of the actuator	2	d	2	High	1,51E-10	4011

Interlock with lock, no contact, coded:

Level of coding acc. to EN ISO 14119:

type 4 acc. to EN ISO 14119

low with F30 actuator

High with F31 actuator

20 years

-20°C ... +50°C

Mission time:

Ambient temperature:

Max. actuation frequency

with actuator lock and release:

Mechanical endurance:

Max. actuation speed:

Min. actuation speed:

Maximum force before breakage F_{1max} :

Max. holding force F_{2h} :

Maximum clearance of locked actuator:

Released actuator extraction force:

600 operating cycles/hour

1 million operating cycles

0.5 m/s

1 mm/s

9750 N acc. to EN ISO 14119

7500 N acc. to EN ISO 14119

4 mm

~ 30 N

Power supply electrical data

Rated operating voltage U_{0} :

Operating current at U_{0} voltage:

24 Vdc \pm 10% SELV

40 mA min.; 0,4 A with activated solenoid;

1,2 A with activated solenoid and all outputs

at maximum power

32 Vdc

1,5 kV

Rated insulation voltage U_{i} :

Rated impulse withstand voltage U_{imp} :

External protection fuse:

Overvoltage category:

Solenoid duty cycle:

Solenoid consumption:

Pollution degree:

2 A type gG or equivalent device

III

100% ED (continuous operation)

9 W max.

3 acc. to EN 60947-1

Electrical data of IS1/IS2/I3/I4/I5/IE1/IE2/EDM inputs

Rated operating voltage U_{01} :

Rated current consumption I_{01} :

24 Vdc

5 mA

Electrical data of OS1/OS2 safety outputs

Rated operating voltage U_{02} :

Output type:

Maximum current per output I_{02} :

Minimum current per output I_{m2} :

Thermal current I_{th2} :

Utilization category:

Short circuit detection:

Overcurrent protection:

Internal self-resettable protection fuse:

Duration of the deactivation impulses at the safety outputs:

Permissible maximum capacitance between outputs:

Permissible maximum capacitance between output and ground:

Activation time of safety outputs OS1 and OS2 after

deactivation of inputs IS1, IS2:

Activation time upon unlocking the guard:

Maximum delay of EDM status change:

24 Vdc

PNP type OSSD

0,25 A

0,5 mA

0,25 A

DC13; U_{02} =24 Vdc, I_{02} =0,25 A

Yes

Yes

1,1 A

< 300 μ s

< 200 nF

< 200 nF

typically 7 ms, max. 15 ms

typically 7 ms, max. 12 ms

500 ms

Electrical data of O3/O4 signalling output

Rated operating voltage U_{03} :

Output type:

Maximum current per output I_{03} :

Utilization category:

Short circuit detection:

Overcurrent protection:

Internal self-resettable protection fuse:

24 Vdc

PNP

0,1 A

DC13; U_{03} =24 Vdc, I_{03} =0,1 A

No

Yes

1,1 A

RFID sensor data

Assured operating distance S_{ao} :

Assured release distance S_{ar} :

Rated operating distance S_n :

Repeat accuracy:

Differential travel:

RFID transponder frequency:

Max. switching frequency:

2 mm

4 mm (actuator not locked)

10 mm (actuator locked)

2,5 mm

\leq 10 % s_n

\leq 20 % s_n

125 kHz

1 Hz



Actuation mode of the OS1 and OS2 safety outputs

Mode 1	Mode 2	Mode 3
Safety outputs OS1 and OS2 are active when the actuator is inserted and locked.	Safety outputs OS1 and OS2 are active when the actuator is inserted.	Safety output OS1 is active when the actuator is inserted and locked and IS1 is active. Safety output OS2 is active when the actuator is inserted and IS2 is active.
In case of machines with or without inertia of the dangerous elements. Safety category of the safety outputs: PL e, SIL 3.	In case of machines without inertia of the dangerous elements. Safety category of the safety outputs: PL e, SIL 3.	In case of machines with or without inertia of the dangerous elements. Safety category of the safety outputs: PL d, SIL 2.

Selection table for switches with high level coded actuators

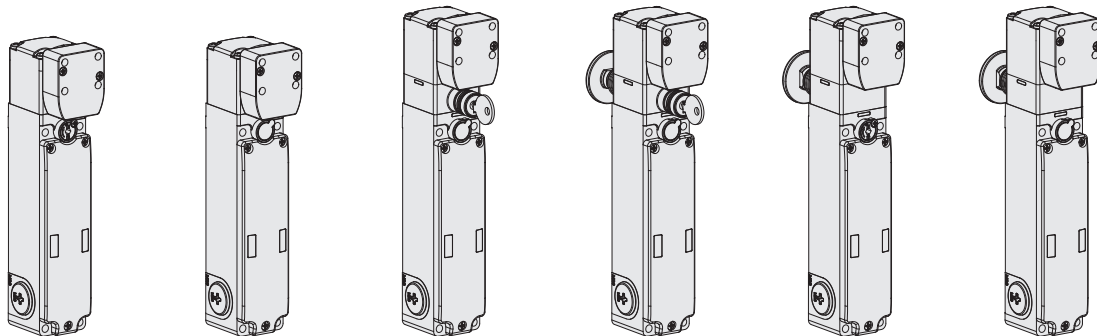

Operating principle	Locked actuator with de-energised solenoid. With sealable auxiliary release device	Locked actuator with energised solenoid.	Locked actuator with de-energised solenoid. With key release.	Locked actuator with de-energised solenoid. With key release and escape release button.	Locked actuator with de-energised solenoid. With escape release button and sealable auxiliary release device.	Locked actuator with energised solenoid. With escape release button.
Mode 1	NG 2D1D411A-F31	NG 2D1E411A-F31	NG 2D5D411A-F31	NG 2D6D411A-F31	NG 2D7D411A-F31	NG 2D7E411A-F31
Mode 2	NG 2D1D421A-F31	NG 2D1E421A-F31	NG 2D5D421A-F31	NG 2D6D421A-F31	NG 2D7D421A-F31	NG 2D7E421A-F31
Mode 3	NG 2D1D431A-F31	NG 2D1E431A-F31	NG 2D5D431A-F31	NG 2D6D431A-F31	NG 2D7D431A-F31	NG 2D7E431A-F31

Selection table for switches

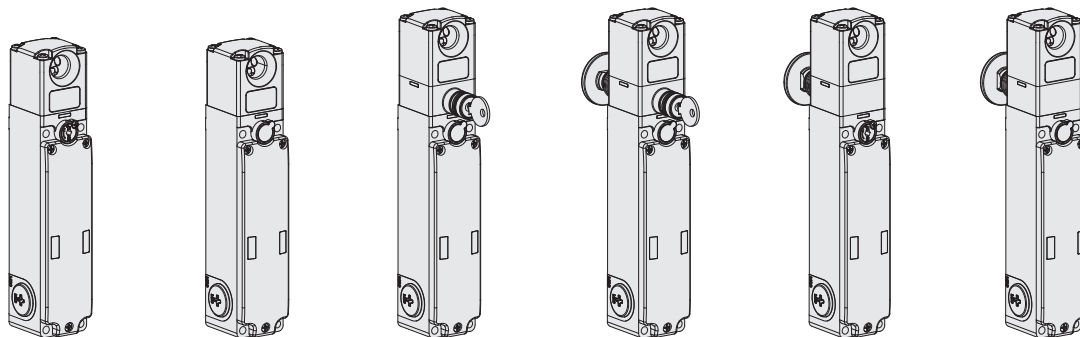

Operating principle	Locked actuator with de-energised solenoid. With sealable auxiliary release device	Locked actuator with energised solenoid.	Locked actuator with de-energised solenoid. With key release.	Locked actuator with de-energised solenoid. With key release and escape release button.	Locked actuator with de-energised solenoid. With escape release button and sealable auxiliary release device.	Locked actuator with energised solenoid. With escape release button.
Mode 1	NG 2D1D411A	NG 2D1E411A	NG 2D5D411A	NG 2D6D411A	NG 2D7D411A	NG 2D7E411A
Mode 2	NG 2D1D421A	NG 2D1E421A	NG 2D5D421A	NG 2D6D421A	NG 2D7D421A	NG 2D7E421A
Mode 3	NG 2D1D431A	NG 2D1E431A	NG 2D5D431A	NG 2D6D431A	NG 2D7D431A	NG 2D7E431A

To order a product with EDM input replace number 4 with number 5 in the codes shown above. Example: NG 2D1D411A → NG 2D1D511A

Legend: interlock with lock monitoring acc. to EN ISO 14119

Selection table for actuators

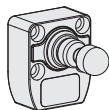

The use of RFID technology in NG series devices makes them suitable for several applications. Pizzato Elettrica offers two different versions of actuators, in order to best suit customers' specific needs.

Type F30 actuators are all encoded with the same code. This implies that a device associated with an actuator type F30 can be activated by other actuators type F30.

Type F31 actuators are always encoded with different codes. This implies that a device associated with an actuator type F31 can be activated only by a specific actuator. Another F31 type actuator will not be recognized by the device until a new association procedure is carried out (reprogramming). After reprogramming, the old actuator F31 will no longer be recognized.

Reprogramming of the actuator can be performed repeatedly.

Level of coding acc. to EN ISO 14119	Article
low	VN NG-F30
high	VN NG-F31

Complete safety system

The use of complete and tested solutions guarantees the electrical compatibility between the NG series switches and the safety modules from Pizzato Elettrica, as well as high reliability. The switches have been tested with the modules listed in the adjacent table.

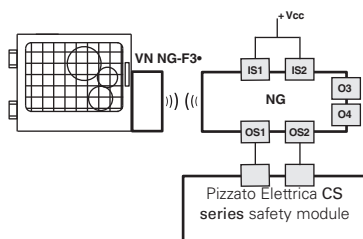

NG series switches can be used as individual devices provided that the safety outputs be evaluated by a Pizzato Elettrica safety module (see table for combinable safety modules).

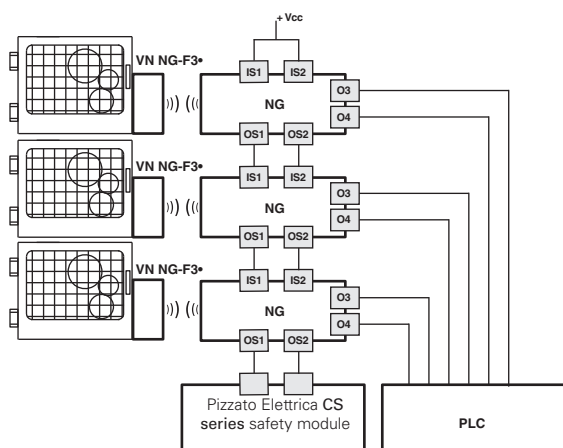

Possibility of series connection of multiple switches for simplifying the wiring of the safety system, whereby only the outputs of the last switch are evaluated by a Pizzato Elettrica safety module (see table with compatible safety modules). Each NG series switch is provided with two signalling outputs which are activated when the guard is closed (O3) or locked (O4). Depending on the specific requirements of the system that has been realised, the signals of the signalling outputs can be evaluated by a PLC.

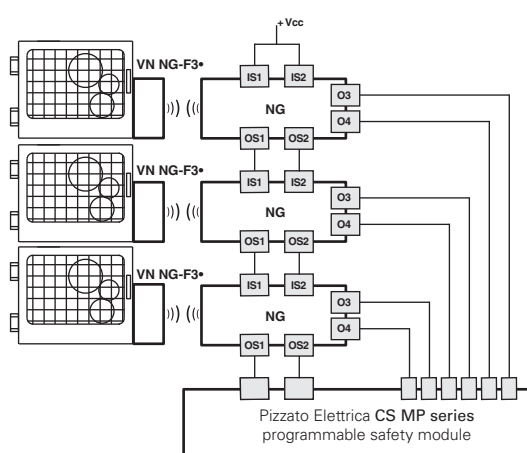

Possibility of series connection of multiple switches for simplifying the wiring of the safety system, whereby only the outputs of the last switch are evaluated by a Pizzato Elettrica safety module of the CS MP series. Both the safety-relevant evaluation and the evaluation of the signalling outputs are performed by the CS MP series.

The examples listed above refer to applications with NG 2•••4•••

Switches	Compatible safety modules	Safety module output contacts		
		Instantaneous safety contacts	Delayed safety contacts	Signalling contacts
NG 2••••••	CS AR-05•••••	3NO	/	1NC
	CS AR-06•••••	3NO	/	1NC
	CS AR-08•••••	2NO	/	/
	CS AT-0•••••	2NO	2NO	1NC
	CS AT-1•••••	3NO	2NO	/
	CS MP•••••			

page 277

page 305

All NG series switches can be connected to safety modules or safety PLCs with OSSD inputs provided compatibility is ensured in advance.

Internal block diagram

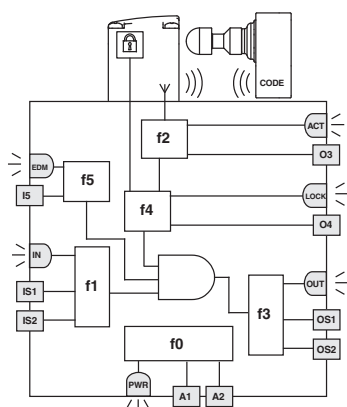

LED	Function
PWR	Power supply / self-diagnosis
IN	status of safety inputs
OUT	status of safety outputs
ACT	actuator state
LOCK	actuator locked
EDM	state of EDM input (NG 2D•••5•••)

The diagram on the side represents the 6 logic functions which interact inside the device.

Function f0 is a basic function and includes the monitoring of the power supply as well as internal, cyclical tests.

Function f1 monitors the status of the device inputs, whereas function f2 monitors the presence of the actuator within the detection areas of the switch.

Function f4 checks the actuator lock condition.

Function f3 is intended to activate or deactivate the safety outputs and check for any faults or short circuits in the outputs.

In the EDM versions, the f5 function verifies the consistency of the EDM signal during safety output state changes.

The safety-related function, which combines the sub-functions mentioned above, activates the safety outputs according to the chosen operating mode:

- Both safety outputs OS1/OS2 for switches in mode 1 are activated only if both IS1/IS2 safety inputs are active and the actuator is inserted and locked;
- Both safety outputs OS1/OS2 for switches in mode 2 are activated only if both IS1/IS2 safety inputs are active and the actuator is inserted;
- The safety output OS1 for switches in mode 3 is activated only if the IS1 safety input is active and the actuator is inserted and locked, whereas the safety output OS2 is activated only if the IS2 safety input is active and the actuator is inserted.

The status of each function is displayed by the corresponding LED (PWR, IN, OUT, ACT, LOCK, EDM), in such a way that the general device status becomes immediately obvious to the operator.



Actuation sequence in mode 1

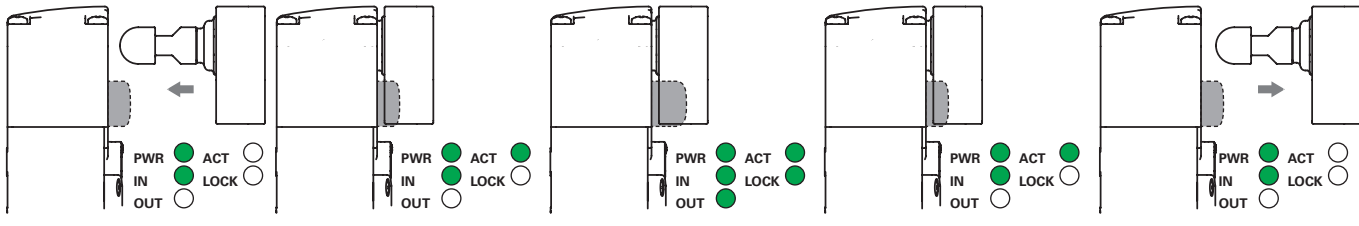

The switch is supplied with power (PWR LED on, green), the IS1 and IS2 inputs are enabled (IN LED on, green), the OS1 and OS2 safety outputs are disabled (OUT LED off). The actuator is outside of the actuation zone (LED ACT off).

When the actuator is brought inside the safe actuation area (dark grey area), the switch turns on the ACT LED (green). In this position, the O3 signalling output (door-closed) is activated. The actuator is not locked (LOCK LED off).

The I4 input can be used to lock the actuator (LOCK LED on, green). The OS1 and OS2 safety outputs are enabled (OUT LED on, green). The O4 signalling output is activated at the same time. The safe actuation area is extended in order to allow greater play for the actuator.

The I4 input can be used to unlock the actuator (LOCK LED off). The switch disables the OS1 and OS2 safety outputs and turns off the OUT LED. The O4 signalling output is deactivated at the same time. The safe actuation area returns to the initial values.

When the actuator leaves the actuation limit area, the device turns off the ACT LED and the O3 signalling output.

Actuation sequence in mode 2 and mode 3

In contrast to the above mode 2 description, the safety outputs OS1 and OS2 are activated when the actuator is detected, and deactivated when the actuator is no longer detectable, in mode 3, the OS1 safety output is active with inserted and locked actuator and IS1 active, the OS2 safety output is active with inserted actuator and IS2 active.

Operating states

PWR LED	IN LED	OUT LED	ACT LED	LOCK LED	EDM LED (a)	Device state	Description
○	○	○	○	○	○	OFF	Device switched off.
●	●	●	●	●	●	POWER ON	Internal tests upon activation.
●	○	○	*	*	●	RUN	Safety inputs of the device not active.
●	●	*	*	*	*	RUN	Activation of safety inputs.
●	◐	○	*	*	*	RUN	Safety inputs incoherence. Recommended action: check for presence and/or wiring of inputs.
●	*	*	●	*	*	RUN	Actuator in safe area. O3 signalling output active.
●	*	*	●	●	○	RUN	Actuator in safe area and locked; O3 and O4 outputs active.
●	●	●	●	●	○	RUN	Mode 1 Activation of safety inputs IS1, IS2. Actuator in safe area and locked. O3, O4, OS1 and OS2 outputs active.
●	●	●	●	*	○	RUN	Mode 2 Activation of safety inputs IS1, IS2. Actuator in safe area. O3, OS1 and OS2 outputs active.
●	◐	◐	●	●	○	RUN	Mode 3. Actuator present, guard closed and locked, IS1 enabled, IS2 disabled, OS1 enabled, OS2 disabled
●	●	◐	●	○	○	RUN	Mode 3. Actuator present, guard closed and not locked, IS1 and IS2 enabled, OS1 disabled, OS2 enabled
●	*	◐	*	*	*	ERROR	Error on safety outputs. Recommended action: check for any short circuits between the outputs, outputs and ground or outputs and power supply, then restart the device.
●	○	○	◐	○	○	ERROR	Actuator detection error. Check the physical integrity of the device and, in case of failure, please replace the entire device. If undamaged, realign the actuator with the switch and restart the device.
●	○	○	○	○	○	ERROR	Internal error. Recommended action: restart the device. If the failure persists, replace the device.
●	*	○	*	*	●	RUN	EDM signal active (external relay off) ^a
●	●	●	●	●	○	RUN	EDM signal not active (external relay on) ^a
●	○	○	○	○	◐	ERROR	Error in the EDM ^a function

Legend: ○ = off ● = on ◐ = flashing ◑ = alternating colours * = indifferent (a) Available for NG 2D●●5●●● versions only

External device monitoring (EDM)

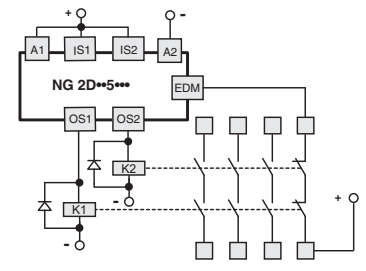

The NG 2D●●5●●● version, in addition to maintaining the operating and safety characteristics of the NG series, allows control of **forcibly guided NC contacts of contactors or relays** controlled by the safety outputs of the switch itself. As an alternative to the relays or contactors you can use Pizzato Elettrica expansion modules CS ME-03. See page 267. This check is carried out via the EDM input (External Device Monitoring as defined in EN 61496-1) of the switch.

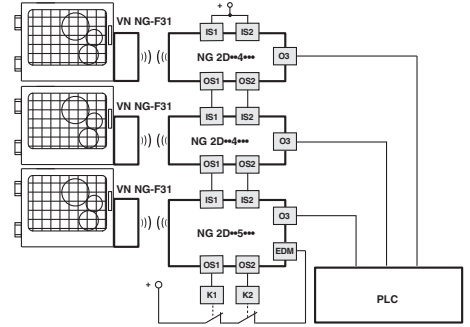

This version, with the IS safety inputs, **can be used at the end of a series of NG switches, up to a maximum number of 32 devices**, while maintaining the maximum PL e safety level and acc. to EN ISO 13849-1 and SIL 3 safety level acc. to EN 62061.

This solution allows you to dispense with the safety module connected to the last device in the chain.

Connection with safety modules

Connections with CS AR-08•••• safety modules

Input configuration with monitored start
2 channels / Category 4 / up to SIL 3 / PL e

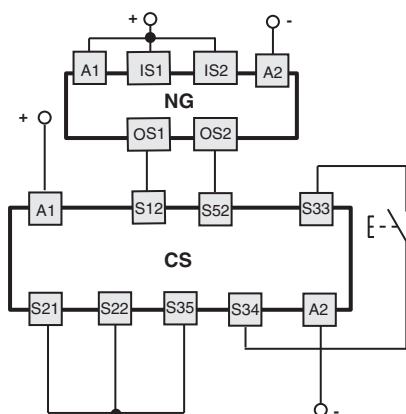

Connections with CS AR-05•••• / CS AR-06•••• safety modules

Input configuration with manual start (CS AR-05••••)
or monitored start (CS AR-06••••)
2 channels / Category 4 / up to SIL 3 / PL e

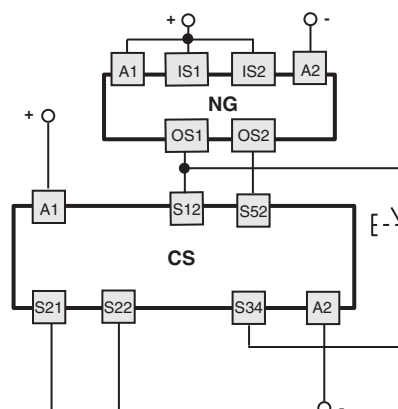

Connections with CS AT-0••••• / CS AT-1••••• safety modules

Input configuration with monitored start
2 channels / Category 4 / up to SIL 3 / PL e

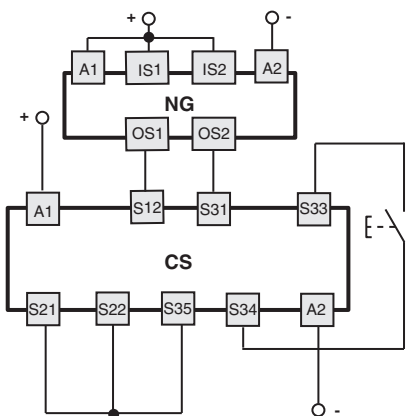

Connections with CS MF•••••, CS MP••••• safety modules

The connections vary according to the program of the module
Category 4 / up to SIL 3 / PL e

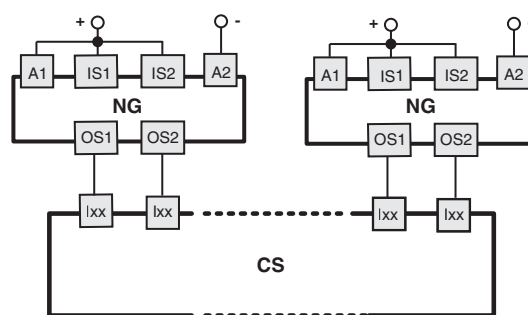

Application example on page 275.

Series connection of several switches

Monitoring function: actuator locked
2 channels / Category 4 / up to SIL 3 / PL e

Single-channel control for locking function of the actuator
1 channel / Category 2 / up to SIL 2 / PL d

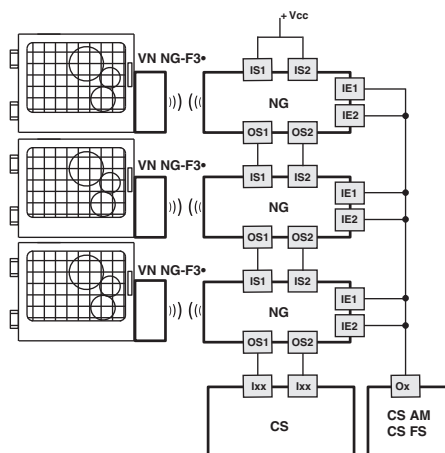

Monitoring function: actuator locked
2 channels / Category 4 / up to SIL 3 / PL e

Dual-channel control for locking function of the actuator
2 channels / Category 4 / up to SIL 3 / PL e

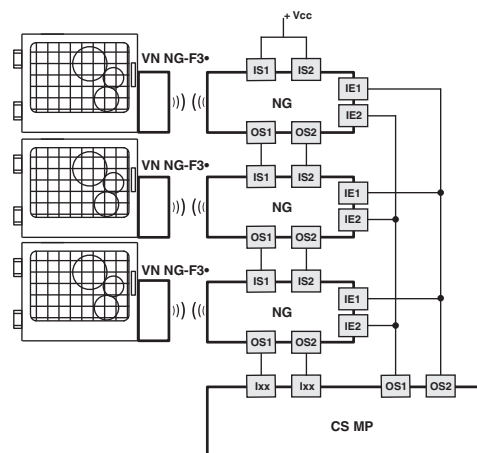

Connection terminals

PUSH-IN type spring-operated connection system

Cross-section of rigid/flexible wires w. wire-end sleeve:

min. 1 x 0.34 mm² (1 x AWG 22)
max. 1 x 1.5 mm² (1 x AWG 16)

Wire cross-section with pre-insulated wire-end sleeve:

min. 1 x 0.34 mm² (1 x AWG 22)
max. 1 x 0.75 mm² (1 x AWG 18)

Cable stripping length (x):

min.: 8 mm
max.: 12 mm





Pin assignments (version with standard cover NG 2D•••1A)

Internal terminal strip	M23 connector 12-pole	M12 connector, 12-pole	M12 connector, 8-pole stand-alone connection	M12 connector, 8-pole series connection with "Y" connectors	Connection
A2	3	3	3	3	A2 Supply input 0 V
B2	3	3	3	3	B2 0 V auxiliary supply output
I4	10	10	8	8	I4 Solenoid activation input for single channel mode (c)
O3	5	5	2	/	O3 Signalling output, actuator inserted (e)
O4	9	9	5	5 (f)	O4 Signalling output, actuator inserted and locked (b) (e)
I3	8	8	6	/	I3 Actuator programming input / reset
IE1	10	10	/	/	IE1 Solenoid activation input for double channel mode
IE2	12	12	/	/	IE2 Solenoid activation input for double channel mode (d)
A1	1	1	1	1	A1 Supply input +24 Vdc
B1	1	1	1	1	B1 Auxiliary supply output +24 Vdc, 8 A max.
IS1	2	2	/	2	IS1 Safety input
IS2	2	2	/	2	IS2 Safety input
I5	6	6	/	6	IS2 Safety input
OS1	11	11	/	/	I5 EDM input (a)
OS2	4	4	4	4	OS1 Safety output
	7	7	7	7	OS2 Safety output

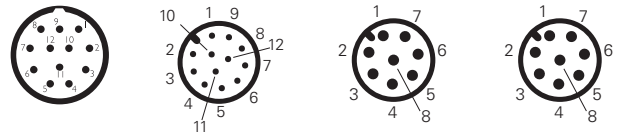
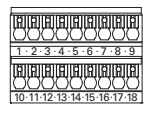
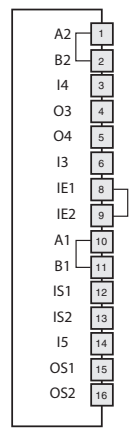

Important: terminals 7, 17, 18, of the internal terminal strip must not be used.

(a) Available in NG 2D••5••• version only.
 (b) For NG 2D••6•••: the output signals the fault condition of the device.
 (c) In single-channel actuation mode, inputs IE1 and IE2 must be short-circuited.
 (d) In double-channel actuation mode, remove the internal bridge between terminals 8-9 and connect the pin 12 wire to the internal terminal 9.
 (e) For NG 2D••7••• articles: the signalling outputs O3 and O4 have negative operating logic (low active signal).
 (f) Available for 8-pole connector, not available for the end of a chain with Y connectors.

Female connectors See page 321

Dimensional drawings

Switch NG 2D1D••1A
Operating principle D, with sealable auxiliary release device, without actuator

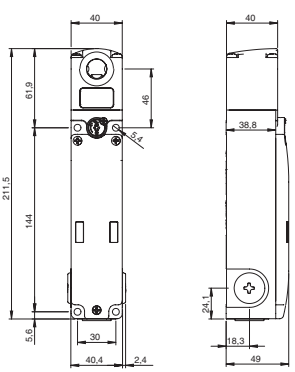

Switch NG 2D1E••1A
Operating principle E, without actuator

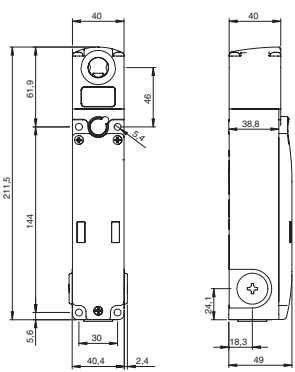

Switch NG 2D5D••1A
Operating principle D, with key release, without actuator

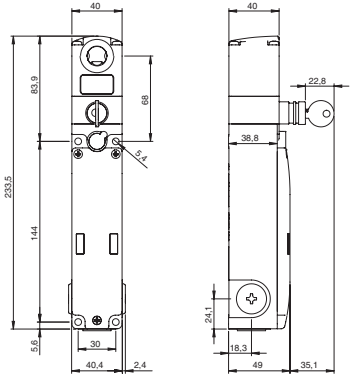

Switch NG 2D6D••1A
Operating principle D, with key release and escape release button, without actuator

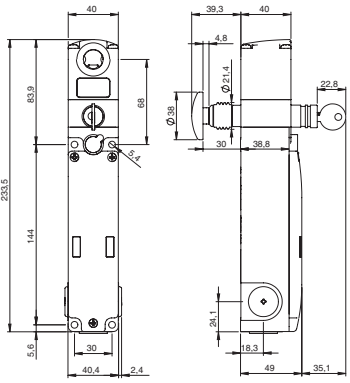

Switch NG 2D7D••1A
Operating principle D, with escape release button, without actuator

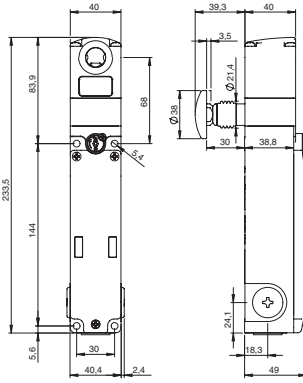

Switch NG 2D7E••1A
Operating principle E, with escape release button, without actuator

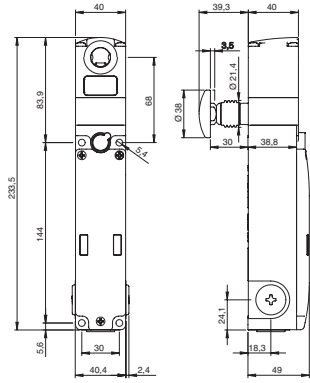

Actuator VN NG-F3•

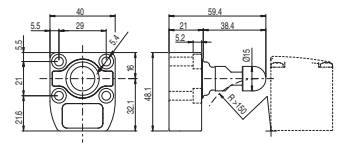

All values in the drawings are in mm

Accessories See page 321

➔ The 2D and 3D files are available at www.pizzato.com

Switch with integrated field-wireable control devices

NG 2D••••1C				NG 2D••••1D				NG 2D••••2V				
	Description	Colour	Terminals		Description	Colour	Terminals		Description	Colour	Terminals	
	Device 1	illuminated button, spring-return 1NO+1NC	white	19 21 31 E- 20 22 34 23 25 32 24 26 34 27 29 28 30	Device 1	illuminated button, spring-return 1NO+1NC	white	19 21 31 E- 20 22 34 23 25 32 24 26 34 27 29 28 30	Device 1	illuminated button, spring-return 1NO+1NC	white	19 21 31 E- 20 22 34 23 25 32 24 26 34 27 29 28 30
	Device 2	illuminated button, spring-return 1NO+1NC	yellow		Device 2	button, not illuminated, spring-return 1NO+1NC	black		Device 2	illuminated button, spring-return 1NO+1NC	blue	
	Device 3	emergency button, not illuminated, with rotary release 2NC	red		Device 3	emergency button, not illuminated, with rotary release 2NC	red		Device 3	emergency button, not illuminated, with rotary release 2NC	red	
	NG 2D••••1E			NG 2D••••1F			NG 2D••••7F					
		Description	Colour	Terminals		Description	Colour	Terminals		Description	Colour	Terminals
	Device 1	illuminated button, spring-return 1NO+1NC	white	19 21 31 E- 20 22 34 23 25 32 24 26 34	Device 1	illuminated button, spring-return 1NO+1NC	green	19 21 31 E- 20 22 34 23 25 32 24 26 34	Device 1	illuminated button, spring-return 1NO+1NC	white	19 21 31 E- 20 22 34 23 25 32 24 26 34
Device 2	button, not illuminated, spring-return 1NO+1NC	black		Device 2	illuminated button, spring-return 1NO+1NC	red		Device 2	illuminated button, spring-return 1NO+1NC	blue		
	NG 2D••••1G			NG 2D••••1H			NG 2D••••3G					
		Description	Colour	Terminals		Description	Colour	Terminals		Description	Colour	Terminals
	Device 1	illuminated button, spring-return 1NO+1NC	green	19 21 31 E- 20 22 34 23 25 32 24 26 34	Device 1	illuminated button, spring-return 1NO+1NC	white	19 21 31 E- 20 22 34 23 25 32 24 26 34	Device 1	illuminated button, spring-return 1NO+1NC	blue	19 21 31 E- 20 22 34 23 25 32 24 26 34

Internal connections (version with integrated control devices)

Terminal no.	Connection	NG 2D••••1C NG 2D••••1D NG 2D••••2V	NG 2D••••1E NG 2D••••1F NG 2D••••7F	NG 2D••••1G NG 2D••••1H NG 2D••••3G
1	A2 Supply input 0 V	A2 1	A2 1	A2 1
2	B2 0 V auxiliary supply output	B2 2	B2 2	B2 2
3	I4 Solenoid activation input for single channel mode (c)	I4 3	I4 3	I4 3
4	O3 Signalling output, actuator inserted (d)	O3 4	O3 4	O3 4
5	O4 Signalling output, actuator inserted and locked (b) (d)	O4 5	O4 5	O4 5
6	I3 Actuator programming input / reset	I3 6	I3 6	I3 6
8	IE1 Solenoid activation input for double channel mode	IE1 8	IE1 8	IE1 8
9	IE2 Solenoid activation input for double channel mode	IE2 9	IE2 9	IE2 9
10	A1 Supply input +24 Vdc	A1 10	A1 10	A1 10
11	B1 Auxiliary supply output +24 Vdc, 1.5 A max.	B1 11	B1 11	B1 11
12	IS1 Safety input	IS1 12	IS1 12	IS1 12
13	IS2 Safety input	IS2 13	IS2 13	IS2 13
14	I5 EDM input (a)	I5 14	I5 14	I5 14
15	OS1 Safety output	OS1 15	OS1 15	OS1 15
16	OS2 Safety output	OS2 16	OS2 16	OS2 16

Terminal no.	Connection	NG 2D••••1C NG 2D••••1D NG 2D••••2V	NG 2D••~•~1E NG 2D••~•~1F NG 2D••~•~7F	NG 2D••~•~1G NG 2D••~•~1H NG 2D••~•~3G
19	Contact 1	19	19	19
20	Contact 2	20	20	20
21	Contact 1	21	21	21
22	Contact 2	22	22	22
23	Contact 1	23	23	23
24	Contact 2	24	24	24
25	Contact 1	25	25	25
26	Contact 2	26	26	26
27	Contact 1	27	27	27
28	Contact 2	28	28	28
29	Contact 1	29	29	29
30	Contact 2	30	30	30
31	Supply input +24 Vdc / LED device 1	31	31	31
32	Supply input +24 Vdc / LED device 2	32	32	32
33	Supply input +24 Vdc / LED device 3	33	33	33
34	Supply input 0 V / LED	34	34	34

Important: terminals 7, 17, 18, of the internal terminal strip must not be used.

(a) Available in NG 2D••~•~5•••• version only.

(b) For NG 2D••~•~6••••: the output signals the fault condition of the device.

(c) In single-channel actuation mode, inputs IE1 and IE2 must be short-circuited.

(d) For NG 2D••~•~7•••• articles: the signalling outputs O3 and O4 have negative operating logic (low active signal).

Internal terminal strip integrated control devices

19	20	21	22	23	24	25	26
27	28	29	30	31	32	33	34



Switch with integrated control devices and M23 connector, 19-pole

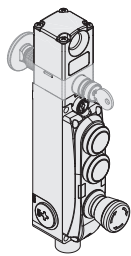

NG 2D••••1C-K603			
	Description	Colour	Terminals
Device 1	illuminated button, spring-return 1NO	white	17 18 6 19
Device 2	illuminated button, spring-return 1NO	yellow	15 16 6 19
Device 3	emergency button, not illuminated, with rotary release 2NC	red	10 13 11 14

NG 2D••••1D-K603			
	Description	Colour	Terminals
Device 1	illuminated button, spring-return 1NO	white	17 18 6 19
Device 2	button, not illuminated, spring-return 1NO	black	15 6
Device 3	emergency button, not illuminated, with rotary release 2NC	red	10 13 11 14

NG 2D••••2V-K603			
	Description	Colour	Terminals
Device 1	illuminated button, spring-return 1NO	white	17 18 6 19
Device 2	illuminated button, spring-return 1NO	blue	15 16 6 19
Device 3	emergency button, not illuminated, with rotary release 2NC	red	10 13 11 14

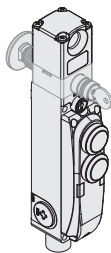

NG 2D••••1E-K602			
	Description	Colour	Terminals
Device 1	illuminated button, spring-return 1NO	white	17 18 6 19
Device 2	button, not illuminated, spring-return 1NO	black	15 6

NG 2D••••1F-K602			
	Description	Colour	Terminals
Device 1	illuminated button, spring-return 1NO	green	17 18 6 19
Device 2	illuminated button, spring-return 1NO	red	15 16 6 19

NG 2D••••7F-K602			
	Description	Colour	Terminals
Device 1	illuminated button, spring-return 1NO	white	17 18 6 19
Device 2	illuminated button, spring-return 1NO	blue	15 16 6 19

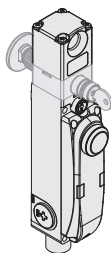

NG 2D••••1G-K601			
	Description	Colour	Terminals
Device 1	illuminated button, spring-return 1NO	green	17 18 6 19

NG 2D••••1H-K601			
	Description	Colour	Terminals
Device 1	illuminated button, spring-return 1NO	white	17 18 6 19

NG 2D••••3G-K601			
	Description	Colour	Terminals
Device 1	illuminated button, spring-return 1NO	blue	17 18 6 19

Internal connections (version with integrated control devices)

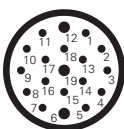

M23 connector, 19-pole	Connection
19	A2 Supply input 0 V
19	B2 0 V auxiliary supply output
1	I4 Solenoid activation input for single channel mode
8	O3 Signalling output, actuator inserted (c)
9	O4 Signalling output, actuator inserted and locked (b) (c)
7	I3 Actuator programming input / reset
/	IE1 Solenoid activation input for double channel mode (d)
/	IE2 Solenoid activation input for double channel mode (d)
6	A1 Supply input +24 Vdc
6	B1 Auxiliary supply output +24 Vdc, 1.5 A max.
2	IS1 Safety input
3	IS2 Safety input
12	I5 EDM input (a)
4	OS1 Safety output
5	OS2 Safety output

Important: terminals 7, 17, 18, of the internal terminal strip must not be used.

(a) Available in NG 2D••••5 version only.

(b) For NG 2D••••6 version: the output signals the fault condition of the device.

(c) For NG 2D••••7 version: the signalling outputs O3 and O4 have negative operating logic (low active signal).

(d) Input not connected.

17	Contact 1	Device 1	
6	Contact 2		
/	Contact 1	Device 2	
15	Contact 2		
6	Contact 1	Device 3	
/	Contact 2		
10	Contact 1		
11	Contact 2		
13	Contact 1		
14	Contact 2		
18	Supply input +24 Vdc / LED device 1		
16	Supply input +24 Vdc / LED device 2		
/	Supply input +24 Vdc / LED device 3		
19	Supply input 0 V / LED		

NG 2D••••1C-K603
NG 2D••••1D-K603
NG 2D••••2V-K603

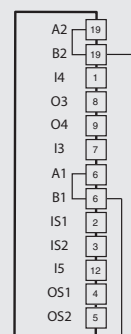

NG 2D••~•1E-K602
NG 2D••~•1F-K602
NG 2D••~•7F-K602

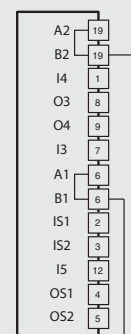

NG 2D••~•1G-K601
NG 2D••~•1H-K601
NG 2D••~•3G-K601

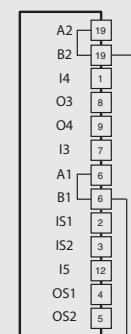

Female connectors See page 321

Dimensional drawings

NG 2D switch with integrated control devices

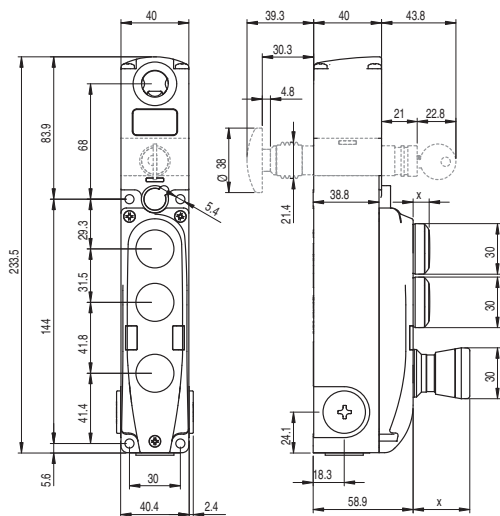

All values in the drawings are in mm

Available integrated devices

	Description	Colours	Article	Combinable with contacts	Installation height (x) mm
	Illuminated button, spring-return	○ White ● Red ● Green ● Yellow ● Blue	VN NG-AC26005 VN NG-AC26001 VN NG-AC26003 VN NG-AC26002 VN NG-AC26004	1NO 2NO 1NO+1NC	10
	Button, not illuminated, spring-return	● Black	VN NG-AC26007	1NO 2NO 1NO+1NC	10
	Indicator light	○ White ● Red ● Green	VN NG-AC26064 VN NG-AC26060 VN NG-AC26062	/	9.7
	Emergency button acc. to EN ISO 13850			2NC	33.4
	Rotary release Push-pull release	● Red ● Red	VN NG-AC26052 VN NG-AC26055		
	Emergency release button, illuminated, acc. to EN ISO 13850			2NC	33.4
	Rotary release Push-pull release	● Red ● Red	VN NG-AC26051 VN NG-AC26054		
	Illuminated selector switch with handle, with transparent lens for LED	● Black ● Black	VN NG-AC26033 VN NG-AC26034	1NO 2NO 1NO+1NC	23.8
	Key selector switch, 2 positions	● Black ● Black	VN NG-AC26040 VN NG-AC26043	1NO 2NO 1NO+1NC	without key 21~ with key 46~
	Closing cap	● Black	VN NG-AC26090	/	4
	Fixing key	● Black	VN NG-AC26080	/	/

Legend: Maintained Spring-return Key extraction position

Other devices and contacts on request.

Please contact our technical office for the complete list of available products.

Technical data of the integrated control devices

General data

Protection degree:	IP65 acc. to EN 60529	
Mechanical endurance:		
Spring-return button:	1 million operating cycles	
Emergency stop button:	50,000 operating cycles	
Selector switch:	300,000 operating cycles	
Key selector switch:	50,000 operating cycles	
Safety parameter B _{10D} :	100,000 (emergency stop button)	

Actuating force

Spring-return button:	4 N min	100 N max.
Emergency stop button:	20 N min	100 N max.
Selector switch:	0.1 Nm min	1.5 Nm max.
Key selector switch:	0.1 Nm min	1.3 Nm max.

Contact blocks of the control devices

Material of the contacts:	silver contacts
Contact type:	Self-cleaning contacts with double interruption

Electrical data:

Thermal current I _{th} :	1 A
Rated insulation voltage U _i :	32 Vac/dc
Rated impulse withstand voltage U _{imp} :	1.5 kV
LED supply voltage:	24 Vdc ± 15%
LED supply current:	10 mA per LED

Utilization category of the contact block:

Direct current: DC13
U _e (V) 24
I _e (A) 0.55

In compliance with standards:

IEC 60947-5-1, IEC 60947-5-5, EN ISO 13850

⚠ Installation for safety applications:

Always connect the safety circuit to the **NC contacts** (normally closed contacts) as stated in standard EN 60947-5-1.

Extensions for release button

Article	Description	Drawing
VN NG-LP30	Metal extension for release button. For max. wall thickness of 30 mm	
VN NG-LP40	Metal extension for release button. For max. wall thickness of 40 mm	
VN NG-LP50	Metal extension for release button. For max. wall thickness of 50 mm	
VN NG-LP60	Metal extension for release button. For max. wall thickness of 60 mm	
VN NG-ERB	Red metal release button	

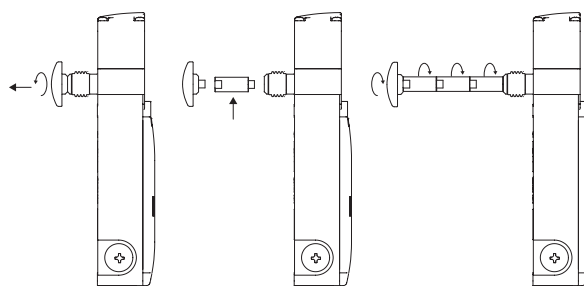

- Metal extensions can be combined with one another to achieve the desired length.
- Do not exceed an overall length of 500 mm between the release button and the switch.
- Use medium-strength thread locker to secure the extensions.

Adhesive labels for escape release button



Polycarbonate yellow adhesive, rectangular, 300x32 mm, red inscription. It has to be fixed on the internal part of the jamb and helps finding the escape release button.

Article	Description
VF AP-A1AGR01	PREMERE PER USCIRE
VF AP-A1AGR02	PUSH TO EXIT
VF AP-A1AGR04	ZUM ÖFFNEN DRÜCKEN
VF AP-A1AGR05	POUSSER POUR SORTIR
VF AP-A1AGR06	PULSAR PARA SALIR
VF AP-A1AGR07	НАЖАТЬ ДЛЯ ВЫХОДА
VF AP-A1AGR08	NACISNAĆ ABY WYJŚĆ
VF AP-A1AGR09	PRESSIÓNAR PARA SAIR

Accessories

Article	Description
VF KLB300	Set of two locking keys



Extra copy of the locking keys to be purchased if further keys are needed (standard supply: 2 units). The keys of all switches have the same code. Other codes on request.

Series connection

To simplify series connections of the devices, various M12 connectors are available that allow complete wiring.

This solution significantly reduces installation times while at the same time maintaining the maximum safety levels PL e and SIL 3.

For further information see page 326.

