

# Operating Manual

## Attachment and Installation Cooling Units DTS and DTI Series 6201 / 6301 Multi Controller (MC) – 230 V

Original instruction manual – Version 1.0, February 2022



Select your language  
by clicking 

Toolbar upper/ left 

-  Betriebsanleitung\_PWI+PWS\_D
-  Operating Manual\_PWI+PWS\_GB
-  Instruction d'utilisation\_PWI+PWS\_F
-  Istruzioni per l'uso\_PWI+PWS\_I
-  Instrucciones de servicio\_PWI+PWS\_E
-  Руководство по эксплуатации\_PWI+PWS\_RU

<b>1</b>	<b>About this manual .....</b>	<b>5</b>
1.1	Use and safekeeping .....	5
1.2	Exclusion of liability .....	5
1.3	Target group .....	6
1.4	Explanation of the notes .....	7
1.5	Marking of contents .....	8
1.5.1	Handling instructions .....	8
1.5.2	Links and cross references .....	8
<b>2</b>	<b>Safety .....</b>	<b>9</b>
2.1	Intended use .....	9
2.1.1	Permissible usage conditions .....	9
2.2	Foreseeable misuse .....	10
2.3	Duty of the operator .....	10
2.4	Terms of warranty .....	11
2.4.1	Returning units .....	11
<b>3</b>	<b>Unit description .....</b>	<b>12</b>
3.1	Unit structure .....	12
3.2	Scope of delivery .....	13
3.3	Order options .....	13
3.3.1	Filter adapter (option) .....	14
3.4	Functional description .....	15
3.4.1	Air circuit .....	15
3.4.2	Controller .....	16
3.4.3	Refrigeration circuit .....	18
3.4.4	Safety concept .....	19
3.4.5	Condensate treatment .....	20
3.4.6	Energy-saving mode .....	21
3.4.7	Multimaster function .....	22
3.5	Type plate .....	23
3.6	Signs and symbols on the unit .....	25
3.7	Technical data .....	26
3.7.1	Refrigeration circuit .....	26
3.7.2	Electrical data .....	27
3.7.3	Dimensions .....	28
3.7.4	Other unit data .....	28

<b>4</b>	<b>Assembly and initial commissioning .....</b>	<b>29</b>
4.1	Safety information.....	29
4.2	Transport.....	30
4.2.1	Transporting the cooling unit.....	31
4.2.2	Crane transport .....	32
4.3	Storage.....	33
4.4	Unpacking .....	33
4.5	Assembly.....	34
4.5.1	General .....	34
4.5.2	DTS cooling unit assembly (side attachment).....	35
4.5.3	Assembly of the DTI cooling unit (Installation).....	37
4.6	Electrical connection .....	40
4.6.1	Notes for connecting cables to the unit.....	40
4.6.2	Electrical circuit diagram .....	41
4.6.3	Connection compartment.....	42
4.6.4	Multimaster Control .....	43
4.6.5	Door contact switch .....	44
4.6.6	Collective fault signal.....	45
4.6.7	Mains connection .....	46
4.6.8	Adapting the unit to the mains voltage .....	48
4.6.9	Equipotential bonding connections.....	48
<b>5</b>	<b>Operation.....</b>	<b>49</b>
5.1	General functions.....	49
5.2	Multi-Controller (MC) operation .....	50
5.2.1	Carrying out menu settings .....	50
5.2.2	Menu overview .....	51
5.3	Operation of the cooling unit .....	52
5.4	Service interface.....	53
5.5	Test mode .....	54
<b>6</b>	<b>Service and maintenance.....</b>	<b>55</b>
6.1	Safety information.....	55
6.2	General .....	56
6.3	Maintenance schedule .....	57
6.4	Maintenance work.....	58
6.4.1	Cleaning.....	58
<b>7</b>	<b>Rectification of operating faults .....</b>	<b>63</b>
7.1	General .....	63
7.1.1	Error messages.....	64
7.1.2	System messages .....	67

<b>8</b>	<b>Decommissioning .....</b>	<b>68</b>
8.1	Temporary decommissioning .....	68
8.2	Final decommissioning.....	68
<b>9</b>	<b>Dismantling and disposal .....</b>	<b>69</b>
9.1	Safety information.....	69
9.2	Dismantling.....	70
9.3	Disposal .....	71
<b>10</b>	<b>Spare parts and accessories .....</b>	<b>72</b>
<b>11</b>	<b>Index .....</b>	<b>73</b>

## 1 About this manual

### 1.1 Use and safekeeping

#### NOTE

---

Read the manual before starting any work on the unit/plant.

---

#### Observe the following points:

- The manual is part of the unit and must always be available on the product and accessible to the operator. The manual must be kept complete, close to the machine and accessible to the respective authorized persons.
- The unit can only be commissioned, operated and serviced properly with the help of this manual.
- This manual refers only to the product specified on the title page.
- This manual is subject to change in the course of technical progress.
- This manual is part of the scope of delivery.
- This manual is valid from transport until final disposal and must be observed.
- Always keep the manual in a legible condition.
- Leave the manual with the unit in the event of a resale.
- The unit can present unavoidable residual hazards for persons and property. Therefore, personnel must read, understand and observe the manual before beginning any work. In addition, every person who works on and with the unit in any way must be instructed and aware of the possible dangers.
- This manual is aimed only at instructed and authorized specialist personnel.
- The owner must ensure that all persons concerned have read and understood the manual before starting work.
- Illustrations in this manual serve for general understanding and can differ from the actual version.

### 1.2 Exclusion of liability

Pfannenberg is not liable for any errors in this documentation. Liability for indirect and direct damages that occur in connection with the delivery or use of this documentation is excluded insofar as this is legally permitted.

Pfannenberg reserves the right to change this document, including the exclusion of liability, at any time without notice and is not liable for any consequences of this change.

### 1.3 Target group

The different activities for handling the unit must be allocated to the target groups.

The necessary personnel qualifications are subject to different legal requirements according to the application site. The owner must ensure that the applicable laws are observed. The admissible personnel and their minimum qualification are defined below insofar as this is not regulated by law.

Observe the following points:

- Work on or with the unit/system may only be performed by suitable specialists.
- The personnel must be familiar with the pertinent standards, regulations, rules for the prevention of accidents and operating conditions.
- The personnel must be instructed and trained for the work to be performed.
- The personnel must be capable of recognizing and avoiding hazards.

Person	Activity	Qualification	Life phase
Load transport specialists	Lifting/setting down and transporting the system	Proven experience in the handling of suspended loads and load securing	Transport, disposal
Specialized personnel (mechanics)	Mechanical work for: Commissioning, troubleshooting, maintenance and decommissioning	Training as industrial mechanics or an equivalent professional qualification	Commissioning, maintenance, troubleshooting, decommissioning, disassembly
Specialized personnel (electrician)	Electrical work	Professional training in electrical engineering or an equivalent professional qualification	Commissioning, maintenance, troubleshooting, decommissioning, disassembly
Operators and users	Operation of the system	By the owner based on the instruction of an instructed person	Commissioning, operation, maintenance, troubleshooting
Specialized personnel (disposal agent)	Proper disposal of the system	Knowledge of the disposal regulations applicable at the application site	Decommissioning, disassembly, disposal

*Tab. 1: Target groups and required personnel qualification*

## 1.4 Explanation of the notes

The warnings are indicated by signal words which express the degree of danger.  
The warnings must be heeded to avoid accidents, injuries and property damages.

Explanation of the warnings in this manual:

### **DANGER**

#### **Brief description of the danger**

The signal word **DANGER** indicates an imminent danger.  
Failure to heed this warning will lead to severe injury or death.

### **WARNING**

#### **Brief description of the danger**

The signal word **WARNING** indicates a possible danger.  
Failure to heed this warning can lead to severe injury or death.

### **CAUTION**

#### **Brief description of the danger**

The signal word **CAUTION** indicates a possible danger.  
Failure to heed this warning can lead to minor to moderate injuries.

### **ATTENTION**

#### **Brief description**

The signal word **ATTENTION** indicates possible property damages.  
Failure to heed the warning can lead to damages to the unit or plant.

### **NOTE**

The signal word **NOTE** indicates further information about the unit or its use.

## 1.5 Marking of contents

### 1.5.1 Handling instructions

Handling instructions are indicated in this manual as follows:

#### Requirements

Requirements and additional warnings

#### Required tools and materials

Tools and materials required for handling

#### Procedure

1. <Handling steps>
  2. ...
    - <Intermediate result / Further instructions>
  3. ...
- ⇒ <Final result>

### 1.5.2 Links and cross references

Links and cross references are indicated in this manual as follows:

- If this document is available in digital form, the links are interactive. A CLICK will bring you to the desired target.
  - The button combination <ALT> + <Cursor left> always returns you to the starting point.
- The table of contents is also interactive.

#### Cross references (example)

For further information, see section "Links and cross references", page 8.



## 2 Safety

### 2.1 Intended use

The Pfannenberg add-on and built-in cooling units of the DTS and DTI series are stationary cooling units for heat dissipation from switch cabinets. They are available in two versions:

- The DTI cooling units are installed partly sunken into the side or door.
- The DTS cooling units are mounted on the side or door.

#### **WARNING**

Risk of injury due to impermissible use of the units.

Improper use of units can lead to serious accidents.

- Only use cooling units in stationary operation.

The DTI/DTS-cooling units are only approved for stationary operation.

As cooling units of protection class IP 55, the cooling units are largely dust-proof.

Limitation: Dust can penetrate despite this under permanent exposure. The cooling units withstand splash water but not a continuous water jet.

The cooling units are available with different cooling capacities. For exact capacity data, see chapter "Refrigeration circuit", Page 26.

The cooling units have a cut-out compatibility with air/air heat exchangers and air/water heat exchangers. The use of aluminum filters, felt filters or bellows filters is possible with an additional adapter.

The cooling units are available with different unit controllers. Cooling units with a Standard Controller (SC) or a Multi-Controller (MC) are available. These controllers are control unit for setting refrigeration functions and operating data. They also enable readout of system messages and diagnostic data.

The Multi-Controller (MC) is additionally equipped with a Multimaster function and an energy-saving mode.

- For detailed data of the controller, see chapter "Technical data", Page 26, "Electrical connection", Page 40 and "Operation", Page 49.

All Pfannenberg cooling units are RoHS compliant and free from:

- Silicone compounds
- PCT, asbestos, formaldehyde, cadmium
- Substances that cause wetting defects

#### 2.1.1 Permissible usage conditions

- The permissible ambient air temperature of the DTI/DTS cooling units is +10 ... 55 °C (+50 ... 131 °F).
- The permissible storage temperature of the DTI/DTS cooling units is -20 ... +70 °C (-4 ... +131 °F).
- The operation of the DTI/DTS cooling units is only permissible for stationary assembly and closed switch cabinets.

## 2.2 Foreseeable misuse

The following points describe a foreseeable misuse of the unit:

- Use of the unit as a storage place, work platform.
- Attachment of transport aids.
- Installation in unsuitable locations.
- Outdoor operation.
- Operation outside of the permissible technical data. See section "Technical data".
- Operation without or with damaged sub-assemblies which serve for the safety of persons and the unit/plant.
- Use of cooling media not listed and approved in the "technical data".
- Cooling of media and objects not intended for operation of the unit.
- Blocking of the ambient air inlets and outlets by set down objects for example.

## 2.3 Duty of the operator

- The operator must ensure that the cooling units are only used for their intended purpose and that all hazards pertaining to the life and health of users or third parties are avoided. The accident prevention guidelines and safety regulations must also be observed.
- Unit faults must be responded to immediately.
- The owner must ensure that all users have read and understood this operating manual.

Non-compliance with this operating manual will void the warranty. The same applies if improper work has been carried out on the unit by the customer and/or third parties without the consent of the manufacturer.

## 2.4 Terms of warranty

### ATTENTION

#### Loss of warranty!

Loss of warranty due to spare parts from other manufacturers.

- Only original parts are subject to quality control by the manufacturer.
- The use of spare parts from other manufacturers will lead to loss of warranty.
- Only use original manufacturer parts to ensure safe and reliable operation.

The warranty does not apply or shall expire in the following cases:

- Improper use of the unit.
- Non-compliance with the operating conditions or non-observance of the operating manual.
- Irregular maintenance of the cooling units.
- Damage due to failure to observe the maintenance recommendations.
- Damage to cooling units caused by dirty or blocked filters.
- Damage due to unauthorized opening of the refrigeration circuit.
- Modifications made to the unit or any change in the serial number.
- Transport damage or other accidents.
- Replacement of parts by unauthorized personnel.

#### 2.4.1 Returning units

The following must be observed to assert warranty claims and to return the unit:

- Attach a precise description of the defect and the SRO (RMA) number assigned by Pfannenberger to the cooling unit.
- Enclose proof of purchase (copy of delivery note or invoice).
- Send the cooling unit with all supplied accessories, in original box or equivalent packaging, free of transport charges and insured.
- Observe transport instructions, see section "Transport", Page 30.

### 3 Unit description

#### 3.1 Unit structure

The Pfannenberg add-on and built-in cooling units of the DTS and DTI series are designed for heat dissipation from switch cabinets. Sensitive components in the switch cabinet are protected. Condensate produced during cooling is discharged through a built-in system.

- The cooling units operate with refrigerant that is very difficult to ignite and is not harmful to the ozone layer.

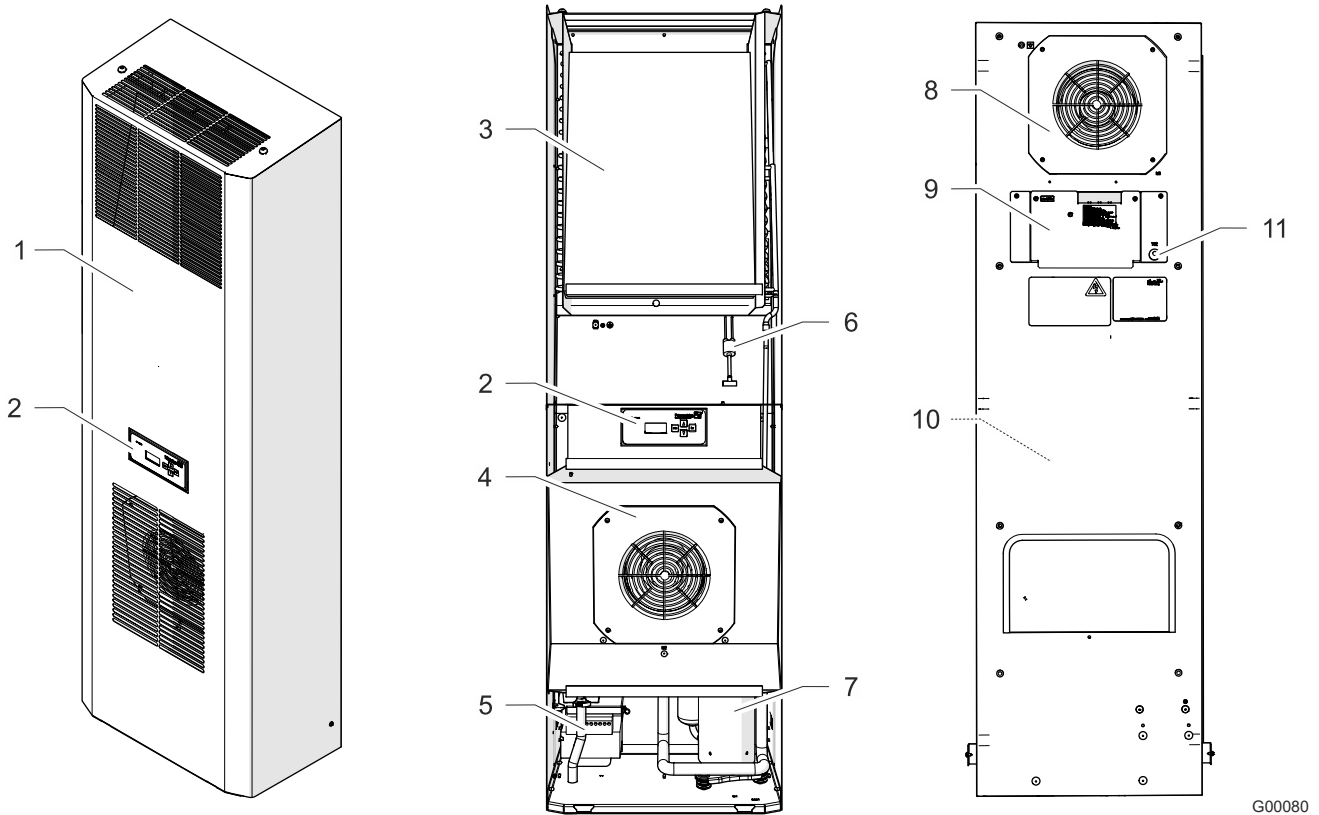

Fig. 1: Unit structure (example DTS cooling unit)

1	Unit cover	7	Compressor
2	Display unit (SC)/control unit (MC)	8	Evaporator fan (internal)
3	Condenser	9	Connection compartment with cover
4	Condenser fan (external)	10	Evaporator (internal)
5	Condensate drain	11	Temperature sensor TS2 (only for MC-Controller)
6	High pressure switch		

### 3.2 Scope of delivery

The scope of delivery consists of:

- DTI/DTS cooling unit
- Brief operating instructions cooling unit
- Accessory kit: According to unit type - e.g. seal, fixing material, electrical plug connectors
- Special accessories if necessary

### 3.3 Order options

#### ATTENTION

#### Damage to the unit!

Damage to the unit due to non-genuine spare parts.

- Only original parts are subject to the manufacturer's quality control.
- For safe and reliable operation, use only original parts of the manufacturer.

The Pfannenberg part number for spare parts can be found in chapter "Spare parts and accessories", Page 72.

An optional extension by a filter adapter for different filter mats (felt filter, pleated filter and metal filter) is available.

- The Pfannenberg part number for accessory orders can be found in chapter "Spare parts and accessories", Page 72.

**3.3.1 Filter adapter (option)**

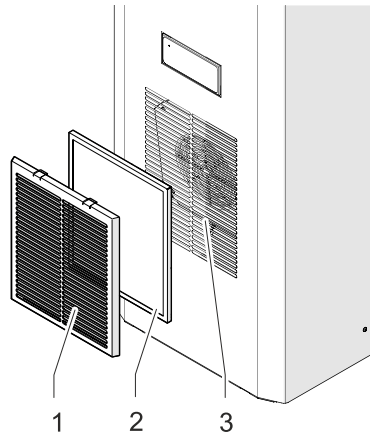

G00052

*Fig. 2: Filter adapter on the cooling unit*

For permanent protection of the external air circuit from contamination, the optional filter adapter (1) can be fitted with a filter mat (2) at the air inlet (3) of the cooling unit.

The filter adapter (1) is simply clipped into the air inlet (3). Only one filter adapter per unit is needed. All filter types are suitable for the adapter.

Order number	Description
18310000151	Filter adapter, RAL 7035
18300000147	Felt filter (standard, dusty air without oil vapors)
18300000148	Pleated filter (longer life, dusty air without oil vapors)
18300000149	Aluminum filter (oily air)

*Tab. 2: Order information filter adapters and filter mats*

### 3.4 Functional description

#### 3.4.1 Air circuit

**⚠ CAUTION**

**Risk of burns**

Risk of burns due to high temperatures at the ambient air outlet. The air outlet can get very hot depending on the ambient temperature.

- Do not hold any parts of the body directly in front of the ambient air outlet (A).

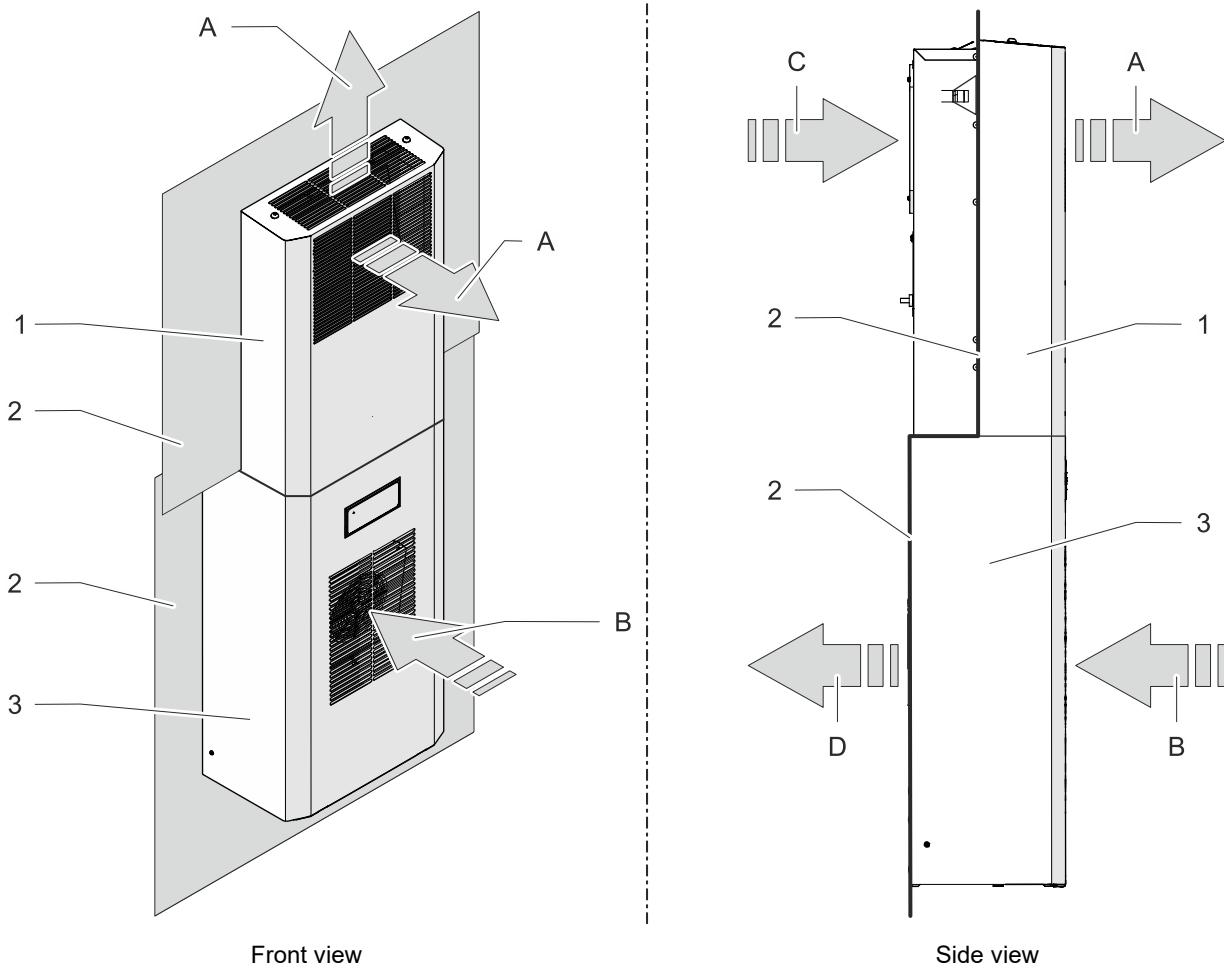

G00001-01

Fig. 3: Air circuit switch cabinet DTI/DTS

A	Ambient air outlet	1	DTI unit cover
B	Ambient air inlet	2	Switch cabinet
C	Hot air inlet (switch cabinet)	3	DTS unit cover
D	Cold air outlet (switch cabinet)		

**NOTE**

The top section of Fig. 3 shows the DTI cooling unit (1) and the bottom section a DTS cooling unit (3).

### 3.4.2 Controller

The controllers are control units for setting refrigeration functions and operating data. They allow readouts of system messages and diagnostic data.

The controllers have a service interface at which different configurations are possible.

They also have a connection for collective fault signals.

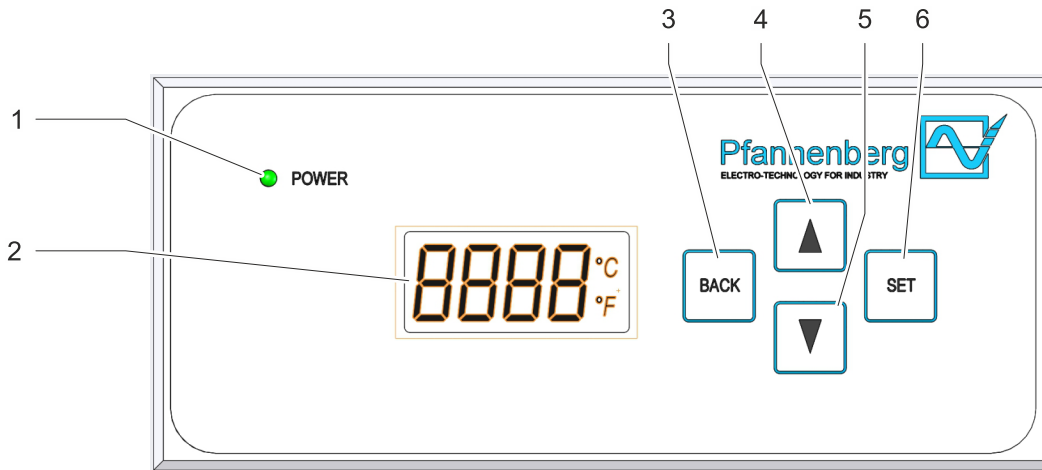

G00018

Fig. 4: Control unit Multi-Controller (MC)

1	LED light	4	SCROLL UP button
2	Control panel	5	SCROLL DOWN button
3	BACK button	6	SET button

Operating/display element	Function
LED light	Indicates the operating mode: Continuous light = fault-free / flashing = operating fault
Control panel (4-digit)	Shows system information: Temperature measuring unit, energy function, operating mode, system data, error number and menu settings/menu items/menu level.
BACK button 	<ul style="list-style-type: none"> <li>Activation of the menu settings.</li> <li>Jump back to the next highest menu level.</li> </ul>
SCROLL UP / DOWN button 	SCROLL UP / DOWN of the menu items or the display elements, in the current menu level.
SET button 	<ul style="list-style-type: none"> <li>Selection of the current menu item.</li> <li>Jump to the next lowest menu level.</li> </ul>





Tab. 3: Operating and display elements on the Multi-Controller



Cooling units with a Multi-Controller (MC) have a control unit with a green LED light and a control panel. The control unit is on the unit cover.

Steady lighting of the green LED light when mains voltage is applied indicates fault-free operating mode. System information is displayed on the control panel.

The following system information displays are possible:

Control panel	System information
	Display – Temperature (°C/°F) of the control sensor in normal operating condition.
	Display – Execute stop mode. Door is open. Alternating display with temperature and stop mode, for fault Er00. Display: StoP → Er00 → Temperature.
	Display - Execution of the energy function, is activated in energy-saving mode Alternating display with temperature display (°C/°F).
	Display - Error number when a fault occurs. In case of a fault, error number (Er01-Er15) alternating with temperature display (°C/°F). Exception error Er00: StoP → Er00 → Temperature.

Tab. 4: System information on the Multi-Controller

For details of error messages, see "Error messages", Page 64.

3.4.3 Refrigeration circuit

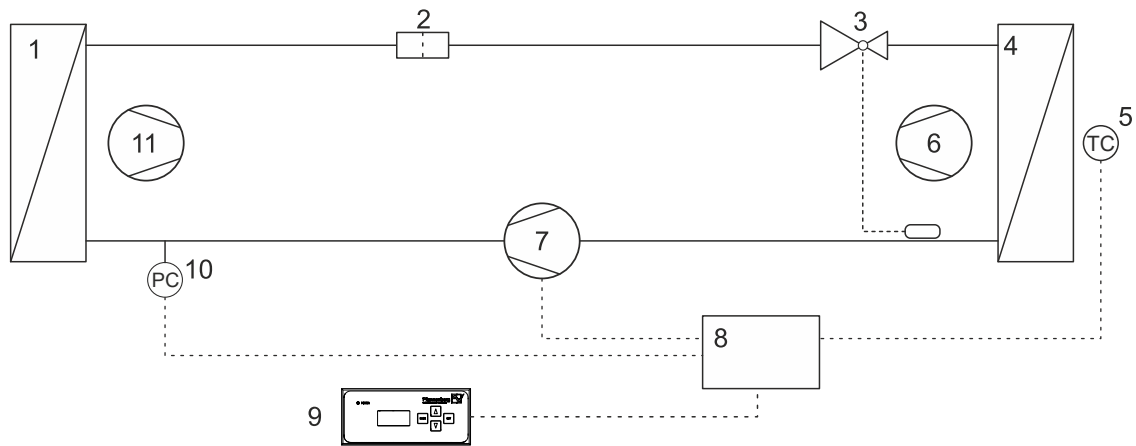

G00004-01

Fig. 5: Refrigeration circuit

1	Condenser	7	Compressor
2	Filter dryer	8	Electronic controller
3	Expansion valve	9	Display unit (SC)/control unit (MC)
4	Evaporator	10	High pressure switch
5	Temperature sensor	11	Condenser (external)
6	Evaporator fan (internal)		

The cooling units consist of different components, see Fig. 5.

- The compressor (7) compresses the refrigerant with high pressure. The temperature rises.
- This heat is dissipated into the ambient air in the condenser (1). The refrigerant becomes liquid.
- The condenser fan (11) sucks in room air through the condenser (1) and discharges it into the ambient air.
- If the refrigerant passes through the expansion valve (3), there is a drop in pressure.
- In the evaporator (4), the refrigerant draws heat from the air inside the cabinet and evaporates it. The air inside the cabinet is cooled and dehumidified.
- The evaporator fan (internal) (6) sucks in the air from inside the cabinet through the evaporator (4) and feeds it back into the switch cabinet as cool air.

The cooling units are controlled by a temperature sensor (5). It measures the air temperature inside the switch cabinet.

### 3.4.4 Safety concept

#### **WARNING**

##### **Risk of injury due to modified safety devices.**

Non-functional, modified or defective safety devices lead to serious accidents.

- All modifications to the unit and especially the safety devices are prohibited.
- In case of defective safety devices, shut down the unit immediately and take it out of operation.

#### 3.4.4.1 Safety devices

- The cooling units have a tested pressure switch in accordance with EN 12263. The pressure switch reacts to a pressure increase in the refrigeration circuit by switching off automatically.
- The fans and compressors are protected against overloading and overheating. For example, the compressor is protected against overspeeding.

#### 3.4.4.2 Additional protection function

Only cooling units with antifreeze option.

- The compressors and fans switch off if there is a danger of freezing.
- The unit must be restarted to exit this switch-off function.

**3.4.5 Condensate treatment**

**⚠ CAUTION**

**Danger of slipping on spilled condensate**

Danger of slipping on condensate spilling onto the floor from the condensate drain hose.

- Collect condensate from the condensate drain hose.

**ATTENTION**

**Damage to the switch cabinet components by formation of condensate**

Switch cabinet interior temperatures below the dew point of the ambient air or damaged switch cabinet seals can lead to excessive condensate formation.

- Check the switch cabinet seals regularly to avoid excessive formation of condensate due to penetrating ambient air.
- Install a door contact switch to reduce formation of condensate when the switch cabinet is open.

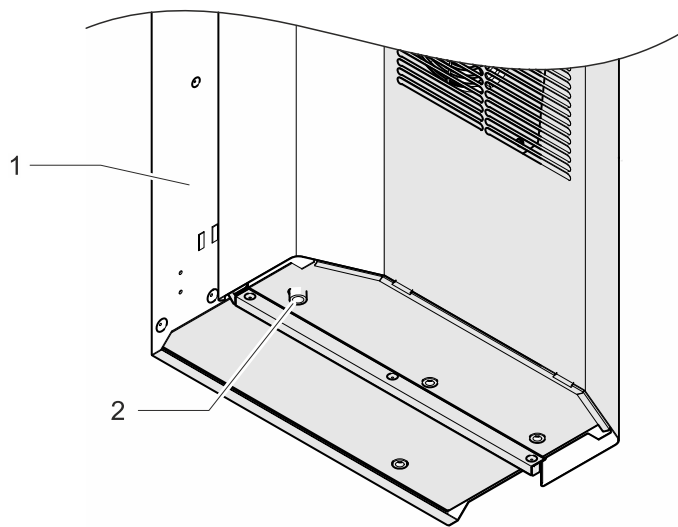

View from below at an angle

G00025

Fig. 6: Condensate drain nozzle (example, DTI cooling unit)

1	Cooling unit	2	Condensate drain hose
---	--------------	---	-----------------------

Condensate can form when the evaporator cools down. The condensate is drained to avoid damage to the switch cabinet and the cooling units. The integrated condensate evaporator discharges the condensate into the ambient air.

For safety reasons, the condensate evaporator has a drain nozzle with drain hose (2) through which the excess condensate is discharged from the unit.

The condensate emerging from the drain hose (2) can be collected in the condensate collection bottle available as an accessory (see "Spare parts and accessories", Page 72).

### 3.4.6 Energy-saving mode

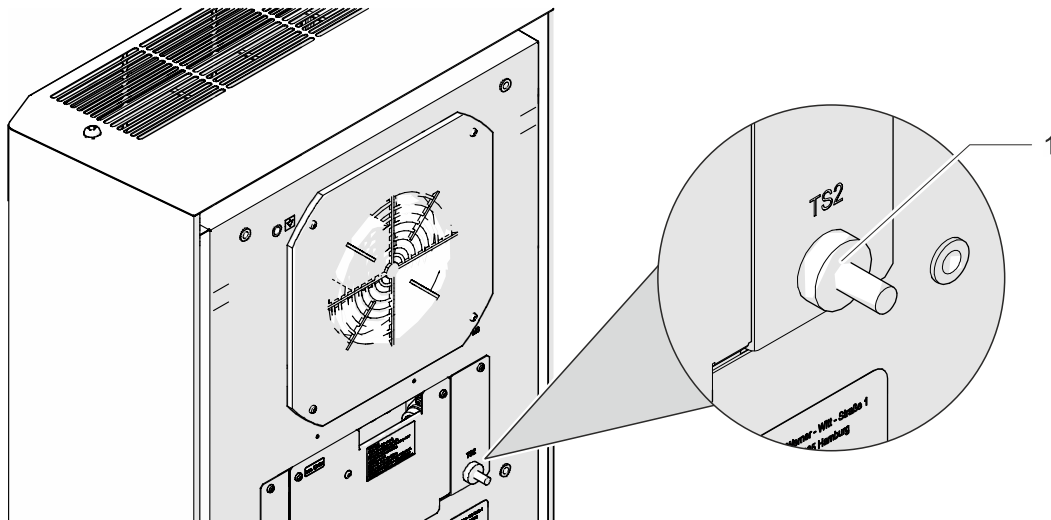

G00068

Fig. 7: Temperature sensor - TS2 for energy-saving mode

Cooling units with Multi-Controllers (MC) have an energy-saving mode.

There is a second temperature sensor TS2 (1) for this on the back of the cooling units which measures the switch cabinet interior temperature.

#### Functional description:

- In the delivery condition, the energy-saving mode is activated if no cooling request is received from the controller for 15 minutes. The control panel then shows "En", see chapter "Controller", Page 16.
- If the switch cabinet interior temperature measured by temperature sensor TS2 exceeds the set temperature setpoint, the evaporator fan (inside the switch cabinet air circuit) is switched off.
- The evaporator fan remains switched on until the switch cabinet interior temperature measured by the temperature sensor TS2 exceeds the set temperature setpoint+2K hysteresis. The evaporator is then switched back on and the energy-saving mode is ended.

### 3.4.7 Multimaster function

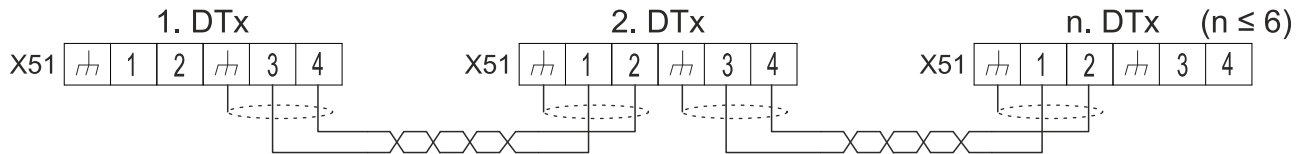

Fig. 8: Multimaster Control

The Multimaster function can control up to six cooling units in the system (bus function). Several cooling units are connected with each other by a 2-wire bus for this.

#### Functional description

- In the bus function, the cooling unit that reaches the switching threshold " $T_{nom} + 2K$ " first activates the cooling mode.
- It is ended by the cooling unit that drops below the switching threshold " $T_{nom} - 2K$ " last.
- The energy-saving mode is ended by the cooling request of one of the cooling units in the bus function.
- The energy-saving mode is reactivated 15 minutes (delivery condition) after the last cooling request of one of the cooling units in the bus function.
- If the minimum temperature alarm is triggered ( $Lit_{\_}$ , falling below the lower temperature limit), check the affected unit. If the unit is part of a Multimaster system, the cooling requirement can be forced from another unit. If this is the case, the proper functioning of each unit involved in Multimaster operation must be checked.

#### NOTE

- 
- All cooling units in the bus function can activate or end the cooling mode or the energy-saving mode. There is no "master and slave function".
  - For details on the electrical connection, see chapter "Electrical circuit diagram", Page 41.
-

### 3.5 Type plate

**⚠ WARNING**

**Risk of injury**

Risk of injury due to failure to heed the type plate specifications.

- Always observe the information on the type plate when installing and maintaining the units.

**NOTE**

- The type plate is on the back of the cooling unit housing.
- The figure shows the standard design adopted by EU member states. The type plate design may differ in other countries.

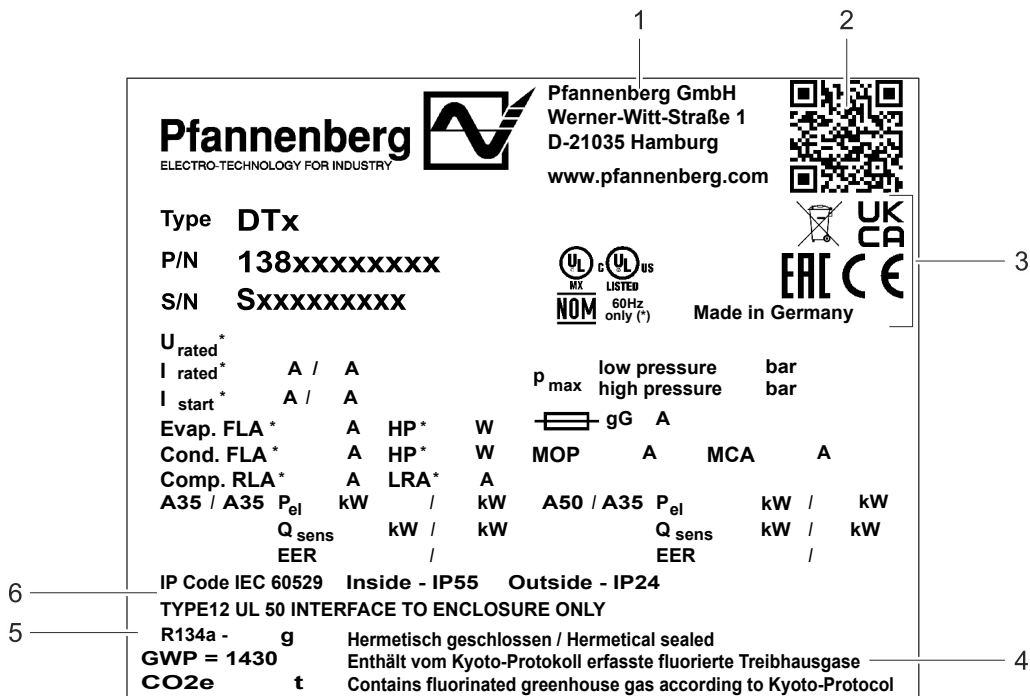

G00005-01

Fig. 9: Type plate (example)

1	Manufacturer address	5	Refrigerant/quantity
2	QR code	6	Housing protection type/NEMA/UL protection classification
3	Designations/approvals		
4	Refrigerant notes: Hermetically sealed, Contains fluoruous greenhouse gases recorded in the Kyoto Protocol		

Value	Description
Type	Unit type
P/N	Part number
S/N	Serial number
U <sub>rated</sub>	Rated voltage/frequency
I <sub>rated</sub>	Nominal current
I <sub>start</sub>	Starting current
 gG	Fuse
Evap. FLA / HP	Evaporator fan Full Load Amps / horse power Full-load current consumption of the evaporator fan/capacity of the evaporator fan in HP
Cond. FLA / HP	Condenser fan Full Load Amps / horse power Full-load current consumption of the condenser fan/capacity of the condenser fan in HP
Comp. RLA / LRA	Compressor Rated Load Amps (RLA) / Locked Rotor Amps (LRA) Nominal current of the compressor/blocking current of the compressor
A35 / A35 A50 / A35	External ambient temperature/temperature in the switch cabinet
P <sub>el</sub>	Electric power consumption
Q <sub>sens</sub>	Cooling capacity
EER	Ratio between power consumption and emitted cooling capacity (Energy Efficiency Ratio)
MOP*	Maximum Overcurrent Protection
MCA*	Minimum Circuit Ampacity
P <sub>max</sub>	Refrigerant pressures
GWP	Global warming potential (Global Warming Potential) of the refrigerant
CO <sub>2e</sub>	CO <sub>2</sub> equivalent of the refrigerant filling

Tab. 5: Type plate data



\* Data for UL-approved units on the design of the protection (MOP) and cable cross-sections (MCA).



### 3.6 Signs and symbols on the unit

The signs and symbols attached to the unit must be observed.

The signs and symbols attached to the unit must not be removed and must be kept in a fully legible condition. Damaged or illegible signs and symbols must be replaced.

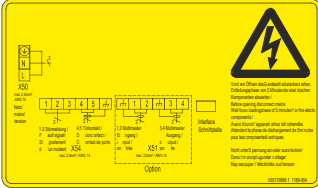
Sign/Symbol	Position	Description
	Rear of unit at the connection for the function equipotential-bonding	Functional equipotential-bonding for a signal reception with low interference between the unit and the switch cabinet.
	Rear of unit at the connection for the protective equipotential-bonding	Protective equipotential-bonding for the connection of metal components and dissipation of a possible touch voltage.
	Rear of unit	<p><b>Connection diagram</b></p> <p><b>Warning</b> – Disconnect power before opening the unit</p> <p><b>X51</b> – connection terminals Multimaster input/output</p> <p><b>X54</b> – connection terminals door contact and fault indication</p> <p><b>X50</b> – connection terminals mains supply</p>
<p>Warning: Risk of electric shock. Can cause injury or death. Disconnect all remote electric power supplies before servicing.</p> <p>Avertissement: Risque de choc électrique. Peut causer des blessures ou la mort. Débranchez toutes les alimentations électriques à distance avant l'entretien.</p>	Rear of unit, cover of the connection terminals	<b>Warning</b> – Danger of electric shock. Switch off power to the unit before working on the unit.

Tab. 6: Signs and symbols on the unit

### 3.7 Technical data

#### 3.7.1 Refrigeration circuit

Designation	Unit	Model DTI / DTS 6201	
Cooling capacity at A35 / A35 */**	Q <sub>0</sub>	W	1150
Cooling capacity at A50 / A35 */**	Q <sub>0</sub>	W	750
Refrigerant type *	–		R134a
Refrigerant quantity *	g		400
Temperature setpoint (factory setting)	°C (°F)		+35 °C (95 °F)
Fault indication: Switch cabinet interior temperature (factory setting)	°C (°F)		SC-Controller: > +50 °C (+122 °F)
			MC-Controller: > +52 °C (+125,6 °F)
Ambient air temperature	°C (°F)		+10 ... 55 °C (+50 ... 131 °F)
Switch cabinet interior temperature	°C (°F)		+25 ... 45 °C (+77 ... 113 °F)
Air volume flow, exterior circuit (free-blowing)	m <sup>3</sup> /h		885
Air volume flow, interior circuit (free-blowing)	m <sup>3</sup> /h		885

Tab. 7: Refrigeration data model DTI / DTS 6201

Designation	Unit	Model DTI / DTS 6301	
Cooling capacity at A35 / A35 */**	Q <sub>0</sub>	W	1550
Cooling capacity at A50 / A35 */**	Q <sub>0</sub>	W	1200
Refrigerant type *	–		R134a
Refrigerant quantity *	g		350
Temperature setpoint (factory setting)	°C (°F)		+35 °C (95 °F)
Fault indication: Switch cabinet interior temperature (factory setting)	°C (°F)		SC-Controller: > +50 °C (+122 °F)
			MC-Controller: > +52 °C (+125,6 °F)
Ambient air temperature	°C (°F)		+10 ... 55 °C (+50 ... 131 °F)
Switch cabinet interior temperature	°C (°F)		+25 ... 45 °C (+77 ... 113 °F)
Air volume flow, exterior circuit (free-blowing)	m <sup>3</sup> /h		885
Air volume flow, interior circuit (free-blowing)	m <sup>3</sup> /h		885

Tab. 8: Refrigeration data model DTI / DTS 6301

\* Data on the type plate.

\*\* The use of optional filter mats reduces the cooling capacity

### 3.7.2 Electrical data

Designation		Unit	Model DTI / DTS 6201
Rated voltage */**		V	230 V, 1~
Rated frequency *		Hz	50/60
Functional area		—	DIN IEC 60038
Power consumption * A35 / A35	P <sub>el</sub> 50 Hz	W	500
	P <sub>el</sub> 60 Hz	W	631
Power consumption * A50 / A35	P <sub>el</sub> 50 Hz	W	573
	P <sub>el</sub> 60 Hz	W	733
Nominal current *	I <sub>nom</sub> 50 Hz	A	3.1
	I <sub>nom</sub> 60 Hz	A	4.8
Start-up current *	I <sub>start max</sub> 50 Hz	A	9.1
	I <sub>start max</sub> 60 Hz	A	9.1
MOP (Maximum Overcurrent Protection)***		A	15.0
MCA (Minimum Circuit Ampacity)***		A	5.5

Tab. 9: Electrical data model DTI / DTS 6201

Designation		Unit	Model DTI / DTS 6301
Rated voltage */**		V	230 V, 1~
Rated frequency *		Hz	50/60
Functional area		—	DIN IEC 60038
Power consumption * A35 / A35	P <sub>el</sub> 50 Hz	W	721
	P <sub>el</sub> 60 Hz	W	845
Power consumption * A50 / A35	P <sub>el</sub> 50 Hz	W	831
	P <sub>el</sub> 60 Hz	W	945
Nominal current *	I <sub>nom</sub> 50 Hz	A	5.0
	I <sub>nom</sub> 60 Hz	A	4.4
Start-up current *	I <sub>start max</sub> 50 Hz	A	19.7
	I <sub>start max</sub> 60 Hz	A	19.7
MOP (Maximum Overcurrent Protection)***		A	15.0
MCA (Minimum Circuit Ampacity)***		A	6.5

Tab. 10: Electrical data model DTI / DTS 6301

\* Data on the type plate.

\*\* In case the rated voltage changes, adapt the upstream fuse, see "Adapting the unit to the mains voltage", Page 48.

\*\*\* Data for UL-approved units on the design of the protection (MOP) and cable cross-sections (MCA).

### 3.7.3 Dimensions

Designation	Unit	Model DTI / DTS 6201
Height	mm	DTI: 1537 DTS: 1540
Width	mm	485
Depth with cover (standard)	mm	218
Installation depth DTI	mm	60
Weight	kg	DTI: 55 DTS: 58
Installation attitude	—	Vertical
Unit construction	—	Standard: Steel sheet Option: With stainless-steel cover

Tab. 11: Dimensions and weight model DTI / DTS 6201

Designation	Unit	Model DTI / DTS 6301
Height	mm	DTI: 1537 DTS: 1540
Width	mm	485
Depth with cover (standard)	mm	218
Installation depth DTI	mm	60
Weight	kg	DTI: 55 DTS: 58
Installation attitude	—	Vertical
Unit construction	—	Standard: Steel sheet Option: With stainless-steel cover

Tab. 12: Dimensions and weight model DTI / DTS 6301

### 3.7.4 Other unit data

Designation	
Anti-corrosion protection	Standard: Galvanized, electrostatically powder-coated (200°C) Variant: Stainless-steel cover (material 1.4301, grounded)
Housing protection type (according to EN 60529)	When used as intended: <ul style="list-style-type: none"> <li>• IP 55 internal – against the switch cabinet.</li> <li>• IP 24 internal – against the environment.</li> </ul>

## 4 Assembly and initial commissioning

### 4.1 Safety information

#### DANGER

##### **Danger of fatal injury due to electric shock!**

Parts may be under voltage when the unit is opened and can cause an electric shock if touched.

Observe the following points when working on the open unit:

- Work on the electrical system may only be carried out by authorized electricians.
- Before commencing work on the electrical system, switch off the power supply, check that no voltage is applied and secure against being switched back on.
- Cordon off the working area and post a warning sign.
- The electrical connection must be made according to nationally valid regulations.

#### CAUTION

##### **Danger of crushing!**

Danger of crushing between the switch cabinet and the unit frame during assembly of the unit.

- Do not place any body parts between the frame and the unit cut-out.
- Work carefully and wear cut-proof gloves.

#### ATTENTION

##### **Damage to the switch cabinet equipment by metal chips**

Metal chips can get into the switch cabinet when fitting the assembly cut-outs.

- Protect the switch cabinet from contamination during assembly and use protective covers.

## 4.2 Transport

Observe the following to avoid personal injury and property damage:

- Work may only be performed by qualified specialists.
- Observe the safety information.

### **WARNING**

#### **Risk of injury for persons!**

Increased risk of injury due to improper transport.

- The unit may only be transported by persons who are familiar with the procedure and aware of the risks as well as having the necessary qualifications.

#### **Danger of crushing by components during transport.**

Components can crush limbs and cause severe injuries during transport.

- Use suitable means of transport.
- Use anti-slip materials for securing, e.g. anti-slip matting.
- Secure loads.
- Use personal protective equipment.

### **WARNING**

#### **Risk of injury for persons!**

Risk of injury due to tipping of the unit in case of improper transport.

- The unit may only be transported by persons who are familiar with the procedure and aware of the risks as well as having the necessary qualifications.
- Secure the unit against tipping during transport.

### **ATTENTION**

#### **Damage to the unit!**

Damage to the unit due to improper transport.

- Observe the information signs (if available) on the unit when transporting it.
- Only transport the unit with suitable lifting gear.
- Only transport the unit in its operating position.

### **NOTE**

The cooling units are always transported in the packaging provided at the factory.  
It consists of a covering carton, base plate, base and top padding.

#### 4.2.1 Transporting the cooling unit

##### Prerequisites

The cooling unit is accommodated in the factory packaging.

##### Required tools and materials

Lashing straps, if necessary loading crane

##### Procedure

1. Secure the unit properly for transport using lashing straps. Always transport in the operating position.
  2. Only lift the unit by its housing.
  3. Always raise the cooling unit slowly and evenly and park it securely.
- ⇒ The cooling unit was properly transported and loaded.

---

##### NOTE

The cooling unit can also be lifted by means of M8 jack rings.

Observe the information in chapter "Crane transport", Page 32 for crane transport.

---

## 4.2.2 Crane transport

### **DANGER**

#### **Danger to life due to suspended loads**

Tipping or falling loads can cause severe to fatal injuries.

- Never stand beneath suspended loads.
- Only use approved lifting gear and slings which are designed for the total weight of the attached load.
- Only use slings/load handling devices in technically perfect condition.
- Observe the sling points and center of gravity of the load.
- Secure loads with suitable devices.

### **WARNING**

#### **Risk of injury due to improper crane transport**

Moving switch cabinets with integrated cooling units can lead to accidents.

- Lifting by M8 jack rings is only permitted for the cooling unit.
- Make sure that jack rings and unit threads are not damaged and deformed.
- Use only jack rings with sufficient thread length in accordance with DIN 580 and check their fit.

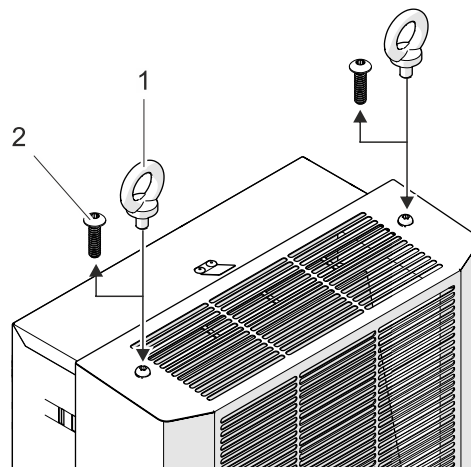

G00006-01

Fig. 10: M8 jack rings DTI/DTS cooling units

1	M8 jack rings	2	Unit cover fastening screws
---	---------------	---	-----------------------------

The cooling units have screw-in threads for M8 jack rings. Cooling units with screwed in M8 jack rings can be used for crane transport .

#### **Prerequisites**

- The unit has been unpacked completely.
- Observe the minimum screw-in depth of the M8 jack rings according to DIN 580.
- The M6 jack rings and cooling unit threads are free of damage (corrosion, deformation).
- The fastening screws (2×) were removed from the unit cover.

#### **Procedure**

1. Screw in the M8 jack rings (2×) completely.
  2. Check that the M6 jack rings are securely fitted in the cooling unit as prescribed.
- ⇒ The M8 jack rings are screwed in the cooling unit and the unit can be moved.



### 4.3 Storage

#### ATTENTION

##### Loss of warranty!

Failure to observe the storage conditions will lead to loss of warranty.

Note the following points for storage of the unit:

- Observe the permissible storage temperature of -20 ... +70 °C (-4 ... +131 °F).
- Always store the unit in its operating position.

### 4.4 Unpacking

#### ⚠ WARNING

##### Risk of injury!

Risk of injury for persons due to the heavy weight of the units!

The total weight must be observed when transporting the unit.

- Observe the weight according to section "Dimensions", Page 28.
- Always transport the unit with several persons or suitable lifting gear.
- Use personal protective equipment.

#### ⚠ CAUTION

##### Risk of cutting and injury!

Risk of cutting and injury due to production-related, sharp sheet metal edges on the unit.

- Use personal protective equipment (cut-proof gloves).
- Handle with care.

#### Unpacking the unit

1. Check the packing for transport damages.
2. Remove all transport and packing material.
3. Check the unit for transport damages or other damages after unpacking.
4. If no damage is found, dispose of the packing material in an environmentally friendly way.

If damages occur during transport, observe the following points:

- Notify the transport company and the manufacturer in writing. Always state type designation and serial number in addition.
- Keep the packing material.
- Make a note of external and internal damages.
- Document damage (e.g. by photos).
- The "General Conditions for Deliveries and Services" of the ZVEI (Central Association for the German Electrotechnical Industry) shall apply in the latest version.

#### NOTE

The unit should only be sent back in the original packing to avoid transport damages during return transport.

## 4.5 Assembly

### **WARNING**

#### **Risk of injury!**

Risk of injury for persons due to the heavy weight of the units!

The total weight must be observed when transporting the unit.

- Observe the weight according to section "Dimensions", Page 28.
- Always transport the unit with several persons or suitable lifting gear.
- Use personal protective equipment.

### **CAUTION**

#### **Risk of cutting and injury!**

Risk of cutting and injury due to production-related, sharp sheet metal edges on the unit.

- Use personal protective equipment (cut-proof gloves).
- Handle with care.

### 4.5.1 General

Ensure that the following general requirements are met for safe and reliable operation of the cooling units:

- Choose an installation site for the switch cabinet that ensures adequate ventilation of the cooling unit. The minimum distance of units from each other and from the wall is 200 mm.
- Installations in the switch cabinet must not obstruct air circulation.
- Secure switch cabinet against tilting.
- Make sure that any hinges can bear the extra weight with cooling unit.
- The cooling unit can be installed with or without an external unit cover.
- Protect the installation site from heavy soiling using covers.

4.5.2 DTS cooling unit assembly (side attachment)

4.5.2.1 Making cut-outs for DTS cooling unit

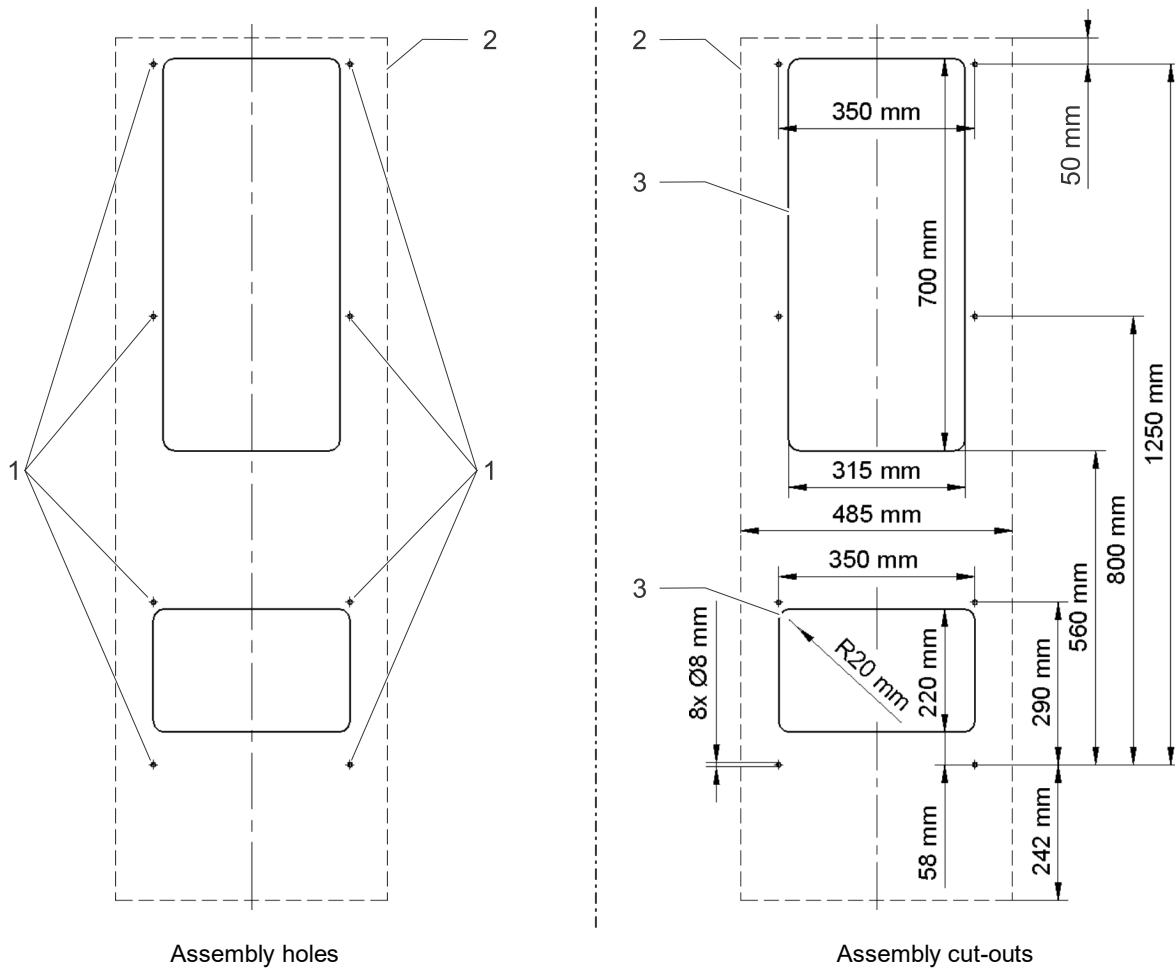

G00007

Fig. 11: External view of switch cabinet, assembly bores and cut-outs

1	Holes	3	Assembly cut-outs
2	Device contour		

Requirements

**⚠ DANGER** – Danger to life due to electric shock. Make sure that the unit is voltage-free.

- All general requirements are satisfied, see "General", Page 34.

Required tools and materials

- Saw
- Switch cabinet milling machine if necessary
- Protective covers

Procedure

1. Ensure that the switch cabinet has a protective cover to protect against chips.
  2. Make cut-outs and assembly holes as shown in Fig. 11.
  3. Deburr the cutting edges.
  4. Remove chips and assembly waste from the switch cabinet.
- ⇒ The cut-outs and holes are made and the cooling unit can be assembled.

**4.5.2.2 Fitting the profile seal**

**ATTENTION**

**Damage to the switch cabinet and the cooling unit!**

Incorrectly fitted seals can lead to excessive formation of condensate in the switch cabinet and thus to short-circuits and damage due to condensate.

- Fit the seal so that it provides sealing against the switch cabinet.
- Make sure that the slotted ends of the seal lie cleanly in front of each other and that the seal joint is centered at the bottom of the cut-out.
- Always check seals during cleaning and maintenance work.

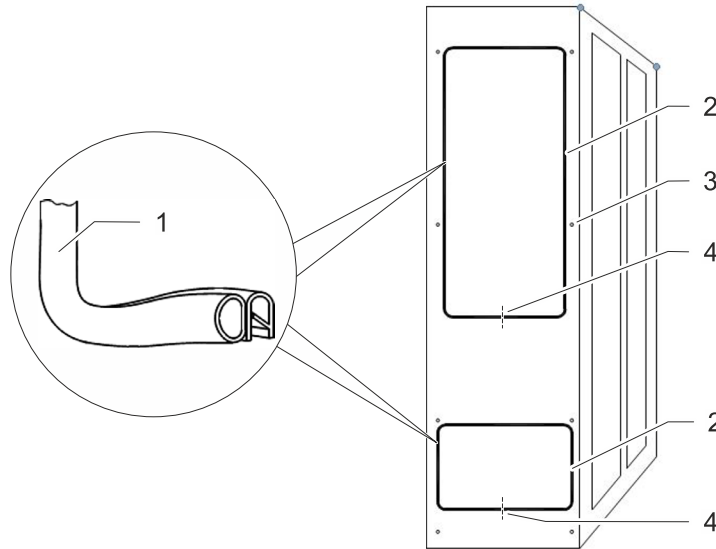

G00008

Fig. 12: Fitting the profile seal

1	Profile seal	3	Switch cabinet interior fastenings
2	Cut-outs for seals	4	Profile seal slotted ends

**Requirements**

**⚠ DANGER** – Danger to life due to electric shock. Make sure that the unit is voltage-free.

- The cut-outs for the DTS cooling unit have been made, see "Making cut-outs for DTS cooling unit", Page 35.

**Required tools and materials**

- Profile seal
- Assembly tool
- Accessory kit: Threaded pins, screws, nuts, washers

**Procedure**

1. Push profile seals onto the sheet edge of the cut-outs. Mount the seals with the slotted ends facing down.
  2. Screw the two included threaded pins (accessory kit) into the upper fastening points of the DTS cooling unit. Hang the cooling unit onto the outside of the switch cabinet with the screwed threaded pins.
  3. Screw the cooling unit to the inside of the switch cabinet. Use the included screws, nuts and washers (accessory kit) for fastening. Tighten the fastenings so that the profile seal is pressed together to a thickness of 2 mm.
- ⇒ The cooling unit is now mounted on the switch cabinet and ready for electrical connection, see "Electrical connection", Page 40.

**4.5.3 Assembly of the DTI cooling unit (Installation)**

**4.5.3.1 Making cut-outs for DTI cooling unit**

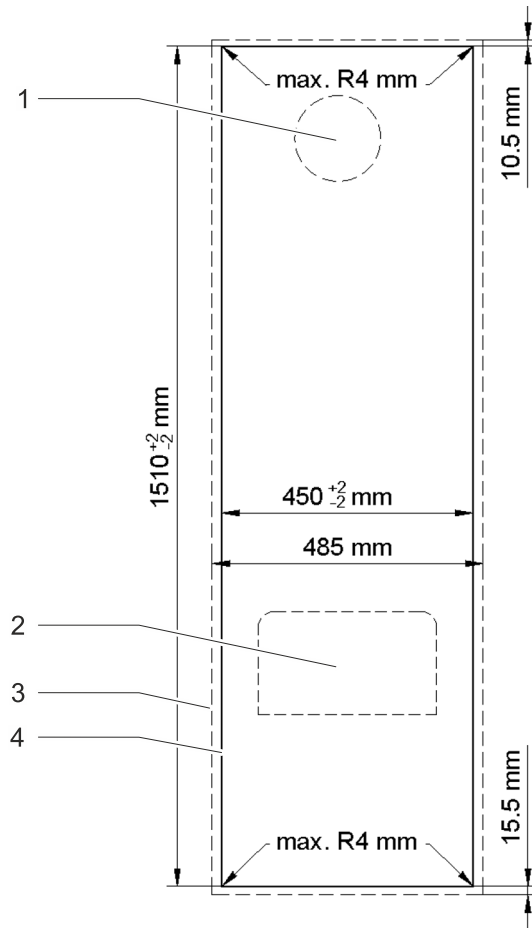

G00009

Fig. 13: External view switch cabinet, assembly cut-outs

1	Air inlet	3	Device contour
2	Air outlet	4	Assembly cut-out

**Prerequisites**

**⚠ DANGER** – Danger to life due to electric shock. Make sure that the unit is voltage-free.

- All general requirements are met, see "General", Page 34.

**Required tools and materials**

- Saw
- Switch cabinet mill if necessary
- Protective covers

**Procedure**

1. Ensure that the switch cabinet has a protective cover to protect against chips.
  2. Provide switch cabinet with cut-outs. For prescribed dimensions, see **Fig. 13**.
  3. The four cut-out corners can be made rectangular or with a max. radius of 4 mm.
  4. Deburr the cutting edge.
  5. Remove chips and assembly waste from the switch cabinet.
- ⇒ The cut-outs and holes are made and the cooling unit can be assembled.

4.5.3.2 DTI cooling unit switch cabinet assembly (installation)

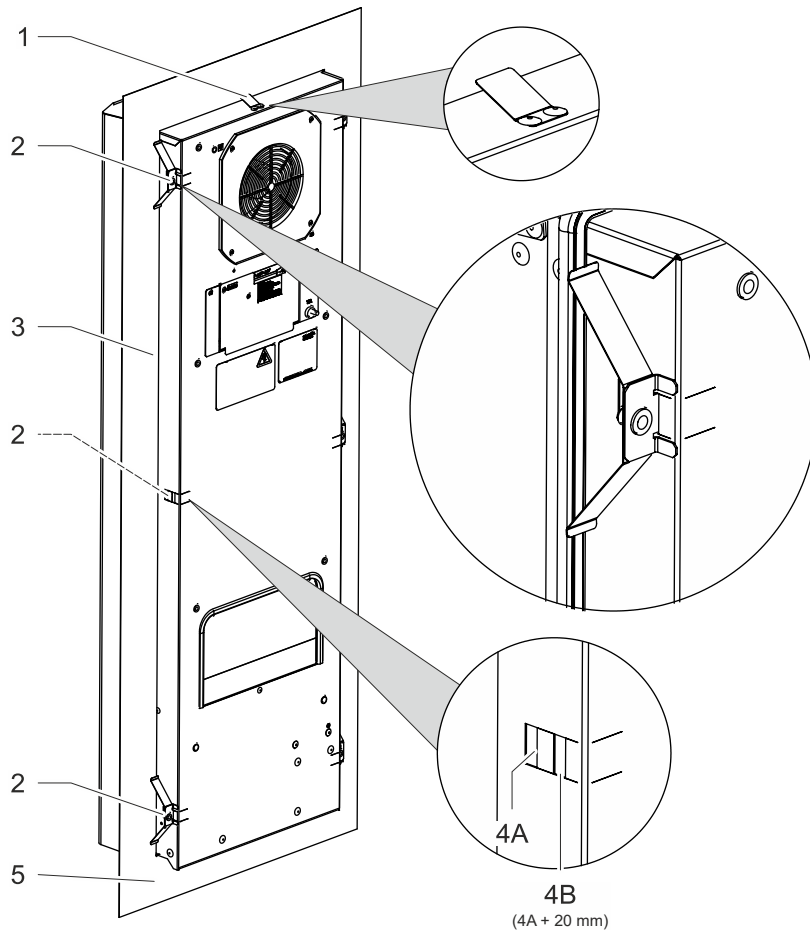

G00010-01

Fig. 14: Assembling the cooling unit

1	Catch spring	4A	Housing cut-out for fastening spring
2	Fastening spring (number depends on the size: DTI 6201 to 6501: 6×; DTI 6801: 10×)	4B	Housing cut-out for fastening spring (for switch cabinets with reinforcing frame)
3	DTI cooling unit	5	Switch cabinet wall/switch cabinet door

**NOTE**



Just scan or click the QR code opposite to watch the assembly video for DTI cooling units.

**Prerequisites**

**⚠ DANGER** – Danger to life due to electric shock. Make sure that the unit is voltage-free.

- The cut-out for the DTI cooling unit is made, see "Making cut-outs for DTI cooling unit", Page 37.

**Required tools and materials**

- Assembly tools, fastening springs (accessory kit).

**Procedure**

1. Place the cooling unit into the cut-out from the outside, see **Fig. 14**.
  2. Push the cooling unit into the switch cabinet until the unit seal is engaged.
  3. The catch spring on the top of the unit snaps in audibly. The cooling unit is now secured against falling out.
  4. Snap in the fastening springs on the inside of the switch cabinet.
  5. Press the fastening springs with your hand so that the bracket hooks into the housing cut-out (4A).
  6. In switch cabinets with stiffening frames, insert the fastening springs in the rear housing cut-outs (4B).
  7. Assemble the cooling unit (3) so that the emergency condensate drain is at the bottom of the unit.
- ⇒ The cooling unit is now mounted on the switch cabinet and ready for the electrical connection, see "Electrical connection", Page 40.

## 4.6 Electrical connection

### **DANGER**

#### **Danger of fatal injury due to electric shock!**

Parts may be under voltage when the unit is opened and can cause an electric shock if touched.

Observe the following points when working on the open unit:

- Work on the electrical system may only be carried out by authorized electricians.
- Before commencing work on the electrical system, switch off the power supply, check that no voltage is applied and secure against being switched back on.
- Cordon off the working area and post a warning sign.
- The electrical connection must be made according to nationally valid regulations.

### **ATTENTION**

#### **Unit malfunction**

Unit malfunction due to wrong field of rotation in the mains connection and due to high-frequency interferences (EMC interferences).

- Make sure that the unit is connected to a three-phase network with right-hand field of rotation.
- Always check the field of rotation before commissioning the unit!
- Interfering electrical installations (high-frequency) must be avoided.
- Signal cables must be laid separately from power cables.

### **ATTENTION**

#### **Wrong connection voltage!**

Wrong connection voltages can damage component parts.

- Compare the connection voltage with the unit type plate. Necessary protection according to section "Electrical data", Page 27.

### 4.6.1 Notes for connecting cables to the unit

Note the following points when connecting the lines to the unit:

- All cables must be supported by a suitable strain relief.
- Maximum cable cross-section 2.5 mm<sup>2</sup> (AWG 14).
- Observe the stripping length of the cable wires for plugs, see connection diagrams of the plugs.
- Observe the connection assignment according to the circuit diagram.



4.6.2 Electrical circuit diagram

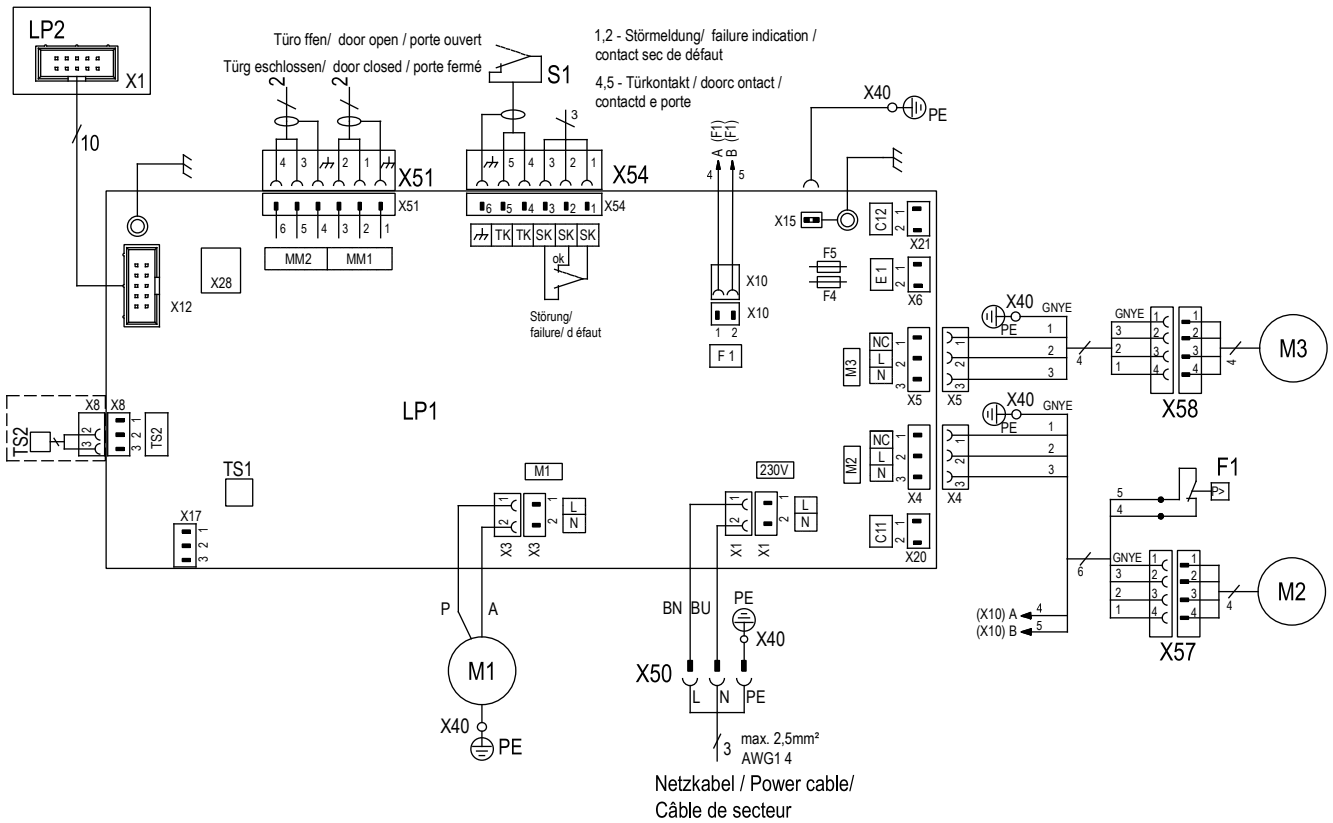

086100114

Fig. 15: Circuit diagram

F1	High pressure switch	MM1	Multimaster input	X28	Service interface
F4-F5	Fuse	MM2	Multimaster output	X40	Ground terminal contact
LP1	Controller	S1	Door contact	X50	Terminal strip mains connection
LP2	Display control unit (MC)	SK	Fault signal contact (terminal 1,2)	X51	Terminal strip multimaster
M1	Compressor	TK	Door contact/signal (terminal 4,5)	X54	Terminal strip door contact + fault indication
M2	Condenser fan (external)	TS1	Temperature sensor (internal)	X57	Terminal strip fan (external)
M3	Evaporator fan (internal)	TS2	Temperature sensor (external)	X58	Terminal strip fan (internal)

4.6.3 Connection compartment

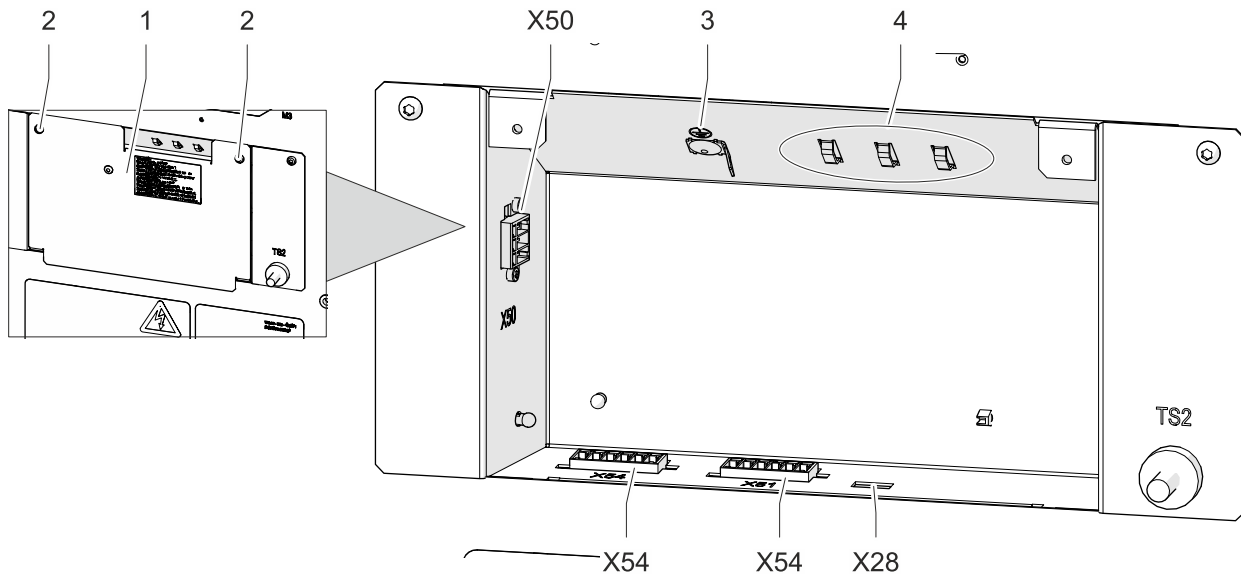

G00095

Fig. 16: Connection compartment

1	Cover plate	X50	Terminal strip mains connection
2	Screws (2×) for cover plate	X51	Terminal strip multimaster control (only for MC-Controller)
3	Grounding connection for cover plate	X54	Terminal strip fault indication/door contact
4	Cable tie eyes for strain relief	X28	Service interface
		F2/F3	Control voltage fuse

The units are connected electrically in the connection compartment. The connection compartment is on the back of the unit behind the cover plate.

**ATTENTION**

The UL approval is voided if the cover plate is not mounted.

- Only operate the unit with the cover plate mounted.

**Prerequisite**

**⚠ DANGER** – Danger to life due to electric shock. Make sure that the unit is voltage-free.

- All general requirements for safe and reliable operation are fulfilled.

**Procedure**

1. Loosen the screws (2) on the cover plate (1) and remove the cover plate. Pull off the grounding connection (4) for the cover plate.
  2. Strip the connecting cables and fasten to the cable tie eyes (5) with cable ties for strain relief.
  3. Make the electrical connections according to the circuit diagram and the following chapters.
  4. Plug on the grounding connection (4) for the cover plate and fix the cover plate with the screws (2).
- ⇒ The cooling unit is connected electrically.

#### 4.6.4 Multimaster Control

**ATTENTION**

**Damage to the unit!**

Damage to the unit and the controller by applying external voltage to the Multimaster inputs/outputs.

- Do not apply external voltage to the Multimaster inputs/outputs (MM1 / MM2).
- The Multimaster inputs/outputs are supplied from the cooling unit with a low voltage (< 20 V, 20 mA).

The Multimaster function can control up to six cooling units in the system (bus function). The connection is made on the input and output side by the terminals MM1 and MM2.

##### 4.6.4.1 Connecting the Multimaster control

**Prerequisites**

**⚠ DANGER** – Danger to life due to electric shock. Make sure that the unit is voltage-free.

**Procedure**

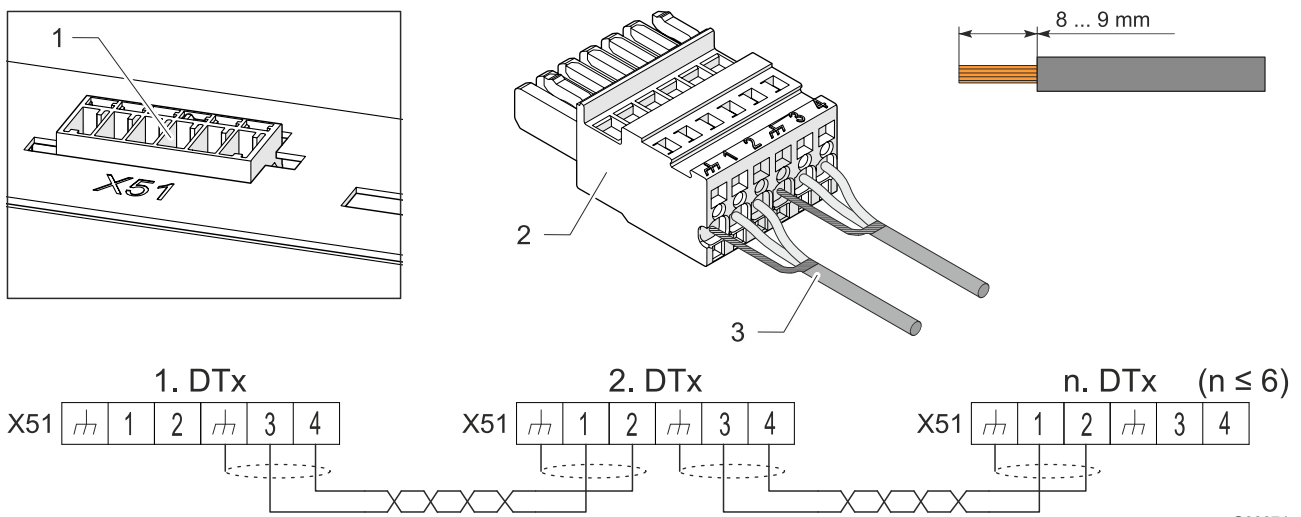

G00074

Fig. 17: Multimaster Control

1	Multimaster connecting plug X51	3	Shielded cable, stripping length 8 to 9 mm
2	Mating plug		

1. Connect the controllers of the cooling units according to the connection diagram and **Fig. 17** on the appropriate terminal strip X51, see "Electrical circuit diagram", Page 41.
    - Use a shielded cable with twisted pairs to avoid interferences. Connect the shield to the terminal for function ground on one side.
    - If shielded cables are not used, make sure that there are no sources of interference in the immediate vicinity. Sources of interference are: Power cables and components with increased electromagnetic radiation, these include, for example, frequency converters or motor drives.
- ⇒ The Multimaster control is connected.

### 4.6.5 Door contact switch

**ATTENTION**

**Damage to the unit!**

Damage to the unit and the controller by applying external voltage to the door contact input.

- Do not apply external voltage to the door contact input.
- The door contact input provides a low voltage (< 20 V, 20 mA) for the door contact switch.

Fitting a door contact switch increases safety and prevents increased condensate formation. The door contact switch switches off the cooling unit motors (fan, compressor) when the switch cabinet is opened.

The door contact switch must interrupt the connection between the terminals **X54:4** and **X54:5** when the switch cabinet door is open.

#### 4.6.5.1 Connecting a door contact switch

**Prerequisites**

**⚠ DANGER** – Danger to life due to electric shock. Make sure that the unit is voltage-free.

**Procedure**

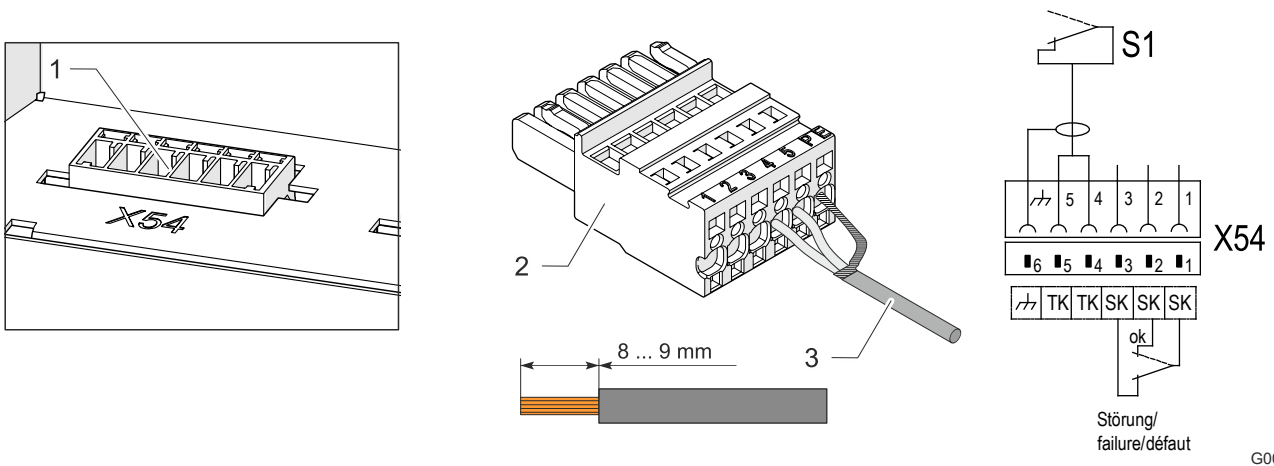

Fig. 18: Connecting a door contact switch

1	Door contact/fault indication plug X54	3	Shielded cable, stripping length 8 to 9 mm
2	Mating plug		

1. Connect the door contact switch (S1) according to the connection plan at the appropriate terminal strip of the controller, see "Electrical circuit diagram", Page 41.
    - Use a shielded cable with twisted pairs to avoid interferences. Connect the shield to the terminal for function ground on one side.
    - If no shielded cables are used, make sure that no sources of interference are laid in the immediate vicinity. Sources of interference are: Power cables and components with increased electromagnetic radiation, these include, for example, frequency converters or motor drives.
  2. Close the switch cabinet, restart the unit and check the function of the door contact switch:
    - Open the switch cabinet door when the unit is running, the motors (fan, compressor) must switch off.
- ⇒ The door contact switch is connected.

### 4.6.6 Collective fault signal

The unit is equipped with a potential-free changeover contact for the collective fault signal.

Three connections are provided for connecting the collective fault signal. The terminals are marked with the device tag SK.

#### 4.6.6.1 Connecting the collective fault signal

##### Prerequisites

**⚠ DANGER** – Danger to life due to electric shock. Make sure that the unit is voltage-free.

##### Procedure

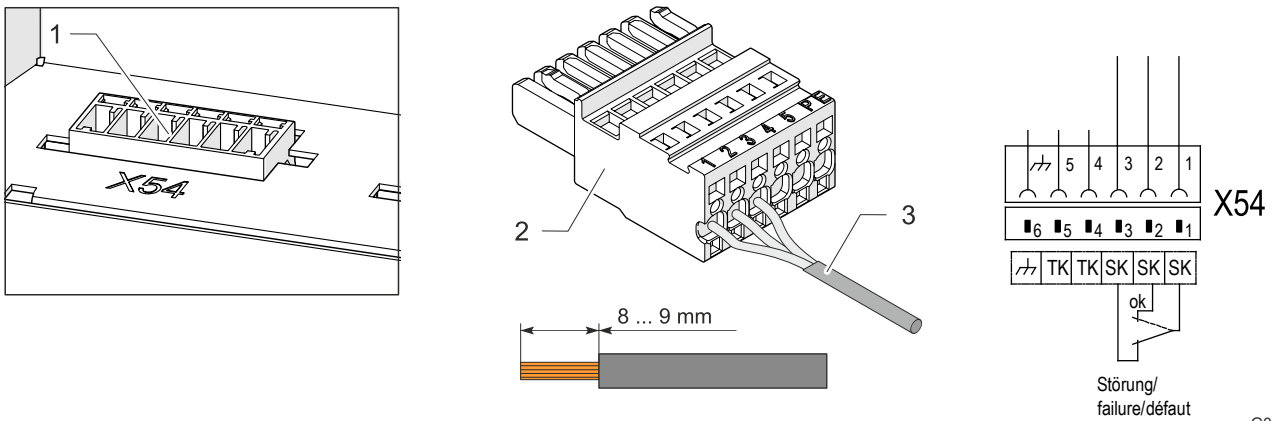

G00076

Fig. 19: Connecting the collective fault signal (example)

1	Door contact/fault indication plug X54	3	Cable for fault indication, stripping length 8 to 9 mm
2	Mating plug		

Terminals	Voltage	Current load capacity	Version
X54:1 root contact	Maximum 230 V	Maximum 1 A	Potential-free changeover contact
X54:2 normally closed (NC)			
X54:3 normally open (NO)			

Tab. 13: Collective fault signal

1. Connect the collective fault signal (SK) according to the connection plan at the appropriate terminal strip of the controller, see "Electrical circuit diagram", Page 41.
- ⇒ The collective fault signal is connected.

#### 4.6.7 Mains connection

##### **DANGER**

###### **Danger of fatal injury due to electric shock!**

Unconnected or incorrectly installed protective conductor systems can generate hazardous voltages and cause electrical shocks resulting in serious accidents.

- Work may only be carried out by qualified specialists.
- Implement protective conductor systems in accordance with DIN EN 60204-1, Section 8.2.
- Every single part of the electrical equipment must be connected to the protective conductor system.
- If parts are removed, e.g. during maintenance work, make sure that the protective conductor system is not interrupted for the remaining parts.

##### **DANGER**

###### **Risk of injury and fire due to electric arcs!**

Electric arcs, dangerous voltages and electric shocks may occur when disconnecting and plugging in the connectors of the mains connection under load or voltage.

- Never plug or unplug mains connectors under voltage.
- Switch off the power supply and secure against switching back on before working on the mains connection.
- Work on the connectors must only be carried out under sufficient lighting.

##### **WARNING**

###### **Risk of fire!**

Risk of fire due to too small cable cross-sections. A too small cable cross-section will result in overheating of the cable.

- Lay cable cross-sections according to the current consumption of the unit and the length of the cable.
- Protect the power cable with the upstream fuse specified on the type plate and in the technical data.

**4.6.7.1 Electrical connection of the cooling unit**

The device corresponds to overvoltage category II.

Fulfill the following general requirements to ensure safe and reliable operation of the cooling unit:

- Connection of an upstream temperature control on the feed side is prohibited.
- Connect the fuse specified on the type plate as line protection, see chapter "Type plate", Page 23 und "Adapting the unit to the mains voltage", Page 48.
- Always connect the cooling unit to the mains via a disconnecting device (switch/contactor).
  - The disconnecting device must have a contact opening of 3 mm and comply with overvoltage category III. The disconnecting device is provided and fitted by the customer.
- Install an all-pole sine filter (phase-phase and phase-earth) when using a frequency converter.

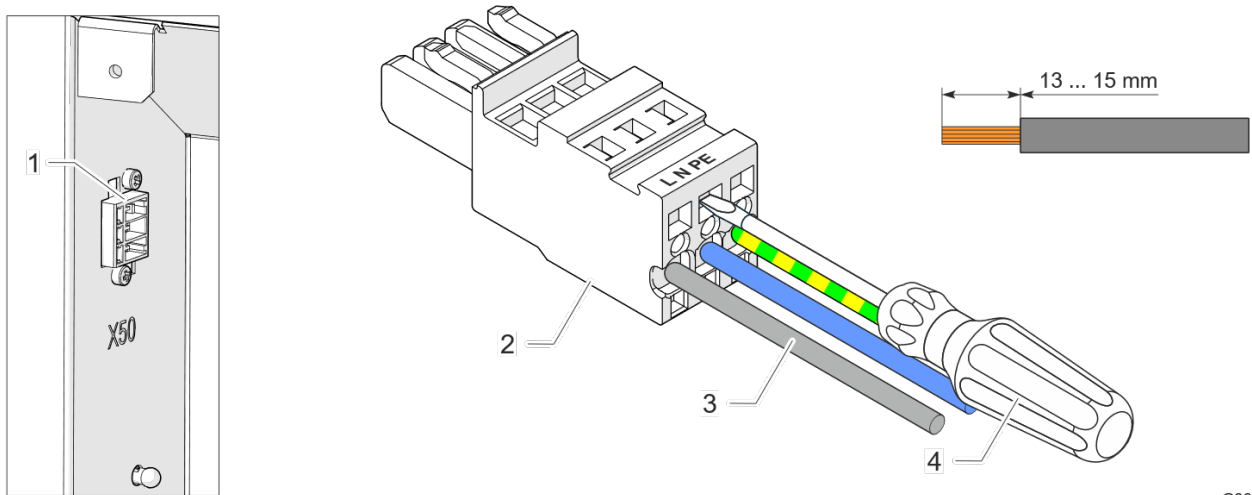

G00089

Fig. 20: Cooling unit mains plug

1	Mains plug X50	3	Cable 1.5 to 2.5 mm <sup>2</sup> , stripping length 8 to 9 mm
2	Mating plug	4	Screwdriver (flat, max. 3.5 mm)

**NOTE**

Protective conductors in the mains connection cable are not regarded as potential equalization conductors.

**Prerequisite**

**⚠ DANGER** – Danger to life due to electric shock. Make sure that the unit is voltage-free.

- All general requirements for safe and reliable operation are fulfilled.

**Procedure**

1. Connect to the mains according to the circuit diagram, see chapter "Electrical circuit diagram", Page 41.
  2. Open the cage clamp terminal of the mating plug with the flat screwdriver and connect the cables on the mating plug.
    - Firmly insert the screwdriver into the cage clamp terminal. Never turn, this will damage the cage clamp terminal.
  3. Plug the mating plug into the mains plug X50.
  4. Before switching on, make sure that the mains voltage matches the data on the type plate.
- ⇒ The cooling unit is connected electrically.

**4.6.8 Adapting the unit to the mains voltage**

**NOTE**

Only cooling units with a rated voltage of 400 / 460 V, 3~ can be optionally connected to another mains voltage.

- Cooling units with the rated voltage 230 / 115 V, 1~ have no transformer options.

**4.6.9 Equipotential bonding connections**

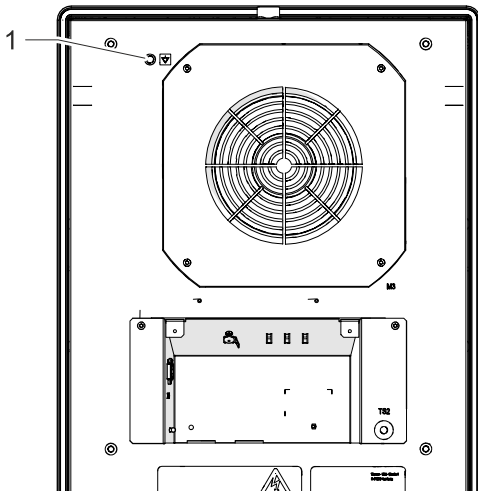

G00092

- 1 Functional equipotential bonding  $\nabla$  (M8-thread), for a signal reception with low interference between the unit and the switch cabinet.

Fig. 21: Equipotential bonding

**NOTE**

Potential equalization provided by customer

If the device is to be integrated into the customer's existing potential equalization for EMC reasons, a conductor can be connected at the connecting point of the function potential equalization.

The connecting point is labeled with the necessary circuit symbol.



## 5 Operation

### 5.1 General functions

#### ATTENTION

##### Damage to the unit

Operation without the unit cover prevents sufficient air supply to the condenser and restricts the intended cooling function.

- Only operate the cooling unit with the unit cover in place.

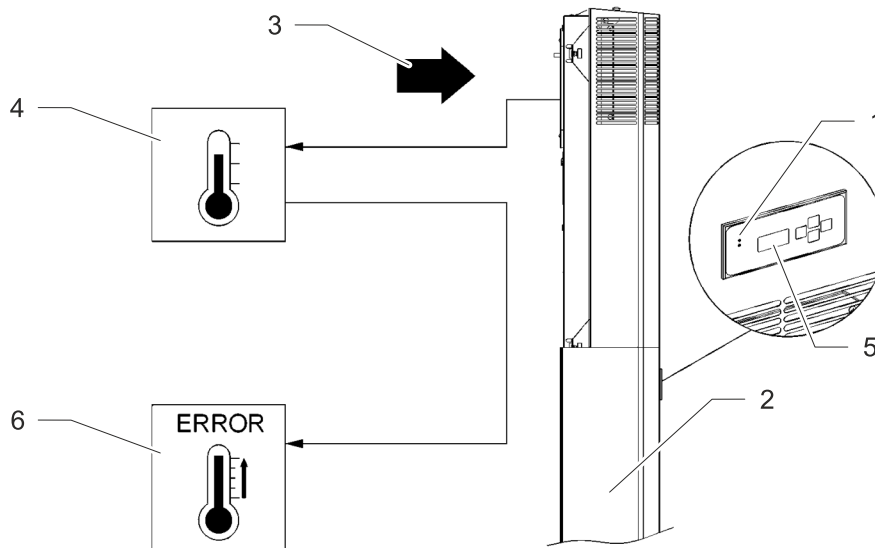

G00021

Fig. 22: Electronic control function

The Multi-Controller (MC) has an indicator unit with a green LED light (1).

If an error occurs, the green LED light (1) flashes and various information is displayed in the control panel (5), see "Controller", Page 16.

- Switch on the power supply to the cooling unit after completing the assembly and installation work.
- The cooling unit (2) starts operation and the LED light (1) of the indicator unit switches to green continuous light. The units run continuously after applying the supply voltage and closing the door.
  - Exception: Energy-saving mode and cooling units with antifreeze option.
  - The external temperature sensor controls the energy-saving mode, see section "Energy-saving mode", Page 21.
- The Multimaster function can connect up to six cooling units in the bus function.
- The control panel (5) shows the current operating states.
- The cooling unit (2) is equipped with an electronic controller. A temperature sensor (4) measures the temperature of the sucked in interior switch cabinet air (3).
- Exceeding or dropping below the lower and upper temperature limit leads to tripping of the fault indication (6).
- The green LED light flashes in the case of a fault indication the control panel (5) shows the error number alternately with the temperature.

#### NOTE

- The ambient conditions and switch cabinet interior temperatures must correspond to the prescribed technical data, see section "Technical data", Page 26.

## 5.2 Multi-Controller (MC) operation

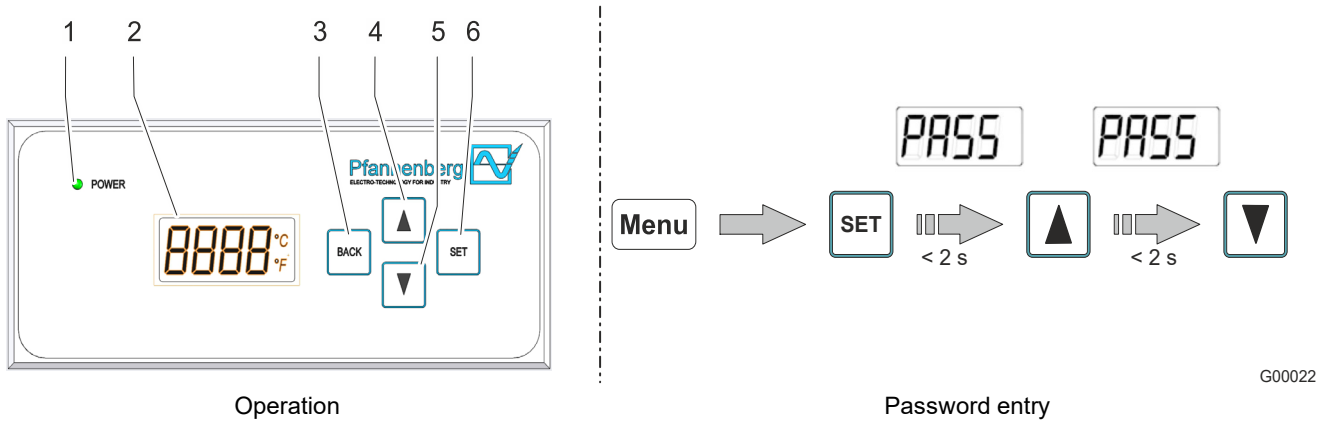

Fig. 23: Multi-Controller (MC) operation

1	LED light	4	SCROLL UP button
2	Control panel	5	SCROLL DOWN button
3	BACK button	6	SET button

The control unit offers four menus which are displayed on the control panel (1).

Control panel	System information	Value range
SEtP	SetP: Setpoint of the switch cabinet temperature.	0 ... 90 °C
Lit <sup>-</sup>	Lit <sup>-</sup> : Maximum value (limit value high) of the switch cabinet temperature	-55 ... 95 °C
Lit <sub>-</sub>	Lit <sub>-</sub> : Minimum value (limit value low) of the switch cabinet temperature	-55 ... 95 °C
Un it	Unit: Unit of the switch cabinet temperature.	°C / °F

Tab. 14: Menus on the Multi-Controller

### 5.2.1 Carrying out menu settings

See also chapter "Menu overview", Page 51.

#### Prerequisite

- The cooling unit has started operation.
- The LED light (1) of the control unit lights green.

#### Procedure

1. Scroll through the menus (SetP, Lit<sup>-</sup>, Lit<sub>-</sub>, Unit) from the temperature display (2) with the SCROLL UP (4) and SCROLL DOWN (5) buttons.
  2. Select a menu with the SET button (6).
  3. Enter the password. After pressing the SET button (6), first press the SCROLL UP button (4) and then the SCROLL DOWN button (5) within two seconds, see Fig. 23 – Password entry.
  4. Set the desired value with the SCROLL UP (4) and SCROLL DOWN (5) buttons.
  5. Confirm the value with the SET button (6).
    - Back with the BACK button (3); the value will not be saved in this case.
  6. Select another menu by scrolling with the SCROLL UP (4) and SCROLL DOWN (5) buttons.
 

**Note** – If no entry is made for 30 seconds, a TIMEOUT occurs and the control panel jumps to the temperature display.
- ⇒ Menu is set in the cooling unit.

5.2.2 Menu overview

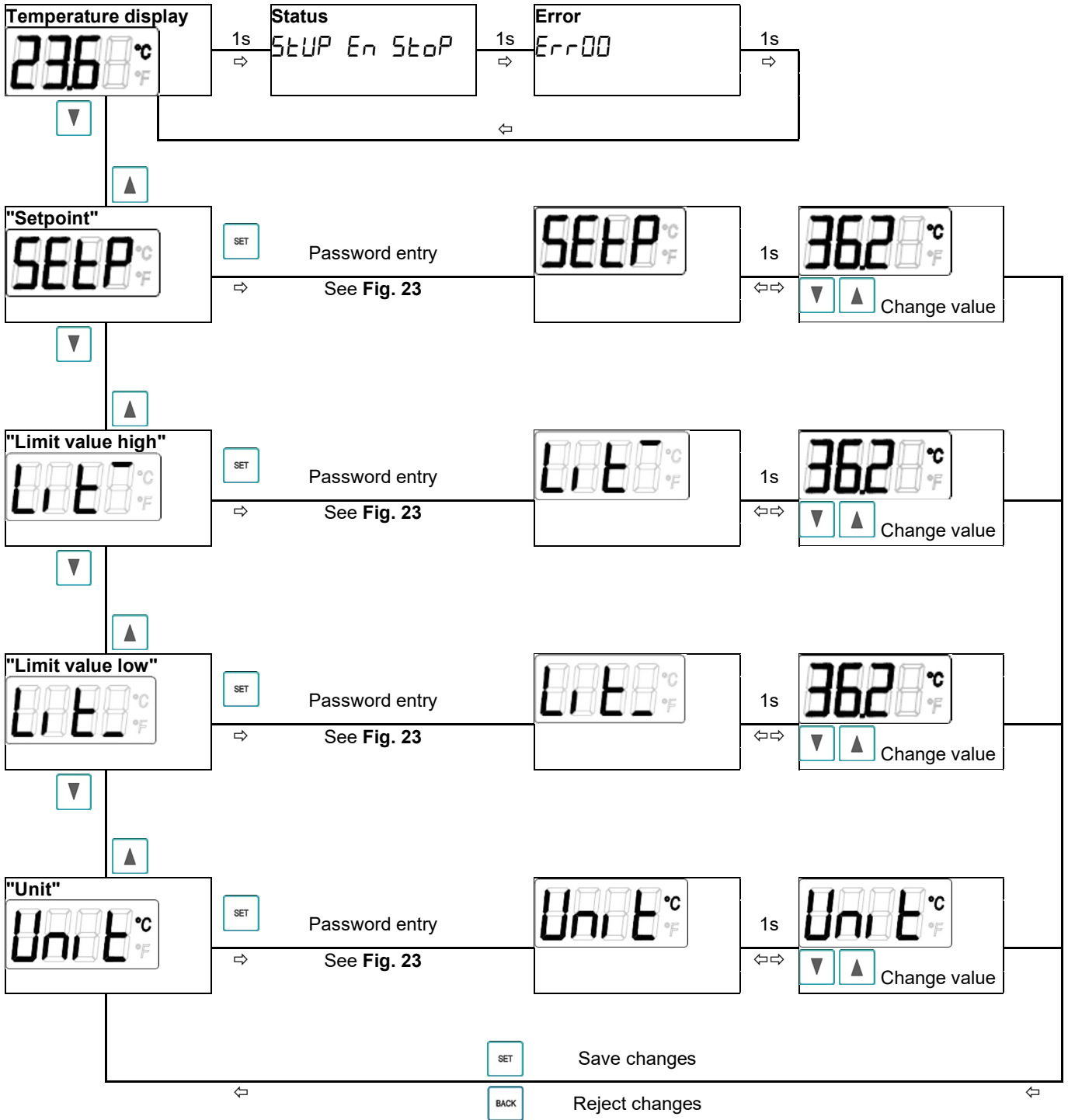

**NOTE**

If no entry is made for 30 seconds, a TIMEOUT occurs and the control panel jumps to the temperature display.

### 5.3 Operation of the cooling unit

#### ATTENTION

##### Damage to the switch cabinet components by formation of condensate

Switch cabinet interior temperatures below the dew point of the ambient air or damaged switch cabinet seals can lead to excessive formation of condensate.

- Check the switch cabinet seals regularly to avoid excessive condensate from penetrating ambient air.
- Install a door contact switch to reduce formation of condensate when the switch cabinet is open.

- The unit goes directly into operating mode after the mains voltage is applied. Which mode it adopts depends on the controller equipment.
- In the operating mode, the cooling unit switches to cooling mode if necessary. This happens depending on whether the temperature switching threshold ( $T_{nom}$ ) is reached or exceeded.
  - The cooling mode switches off if the temperature drops below the temperature switching threshold ( $T_{nom}$ ).
  - The evaporator fan (internal), the condenser fan (external) and the compressor switch off when the door is opened (only with connected door contact switch).

#### 5.3.1.1 Operating conditions

- The mains voltage must be within the specified values, see section "Electrical data", Page 27.
  - A deviation of  $\pm 10\%$  is permitted.
  - The rated frequency must be within  $\pm 3$  Hz of the specified value.
- The ambient air temperature must be below  $55\text{ }^{\circ}\text{C}$ . Other options, see section "Refrigeration circuit", Page 26.
  - Only use cooling units in such a way that the specified cooling capacity can cover the actual demand.
  - Only the specified refrigerant may be used.

#### NOTE

For the Pfannenberg part numbers for spare parts, see section "Spare parts and accessories", Page 72.

**5.4 Service interface**

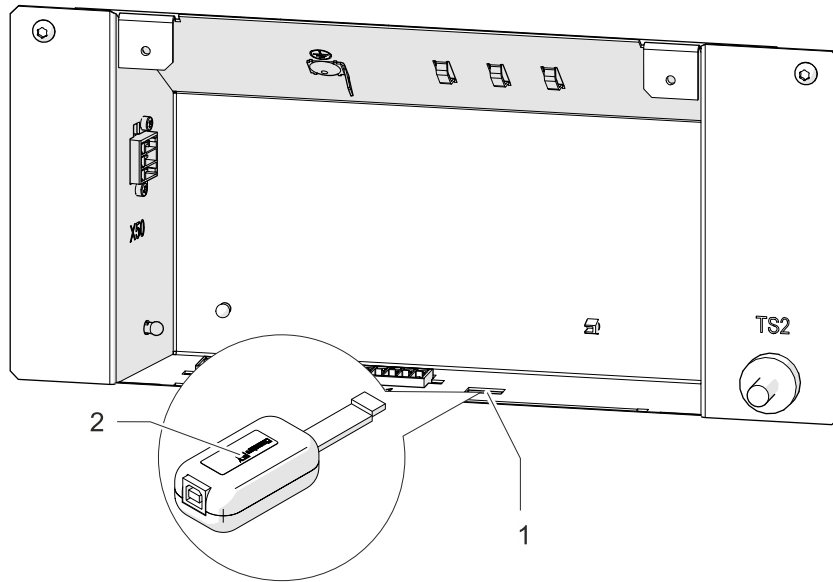

G00097

Fig. 24: Service interface

1	Service interface on the controller	2	USB adapter
---	-------------------------------------	---	-------------

The service interface enables operating parameters to be changed.

- A USB adapter and the configuration software ECoolPLANT 2.X, including the USB driver software are required for this.
- The connection for the USB adapter is marked on the circuit diagram with the device tag X28.
- The USB adapter enables connection to a computer that operates with the configuration software ECoolPLANT 2.X.
  - The USB adapter is available as an accessory, see chapter "Spare parts and accessories", Page 72.
  - Remove the USB adapter from the unit after use. The service interface is only intended for temporary data exchange, e.g. to read out system messages. Continuous operation is forbidden.

**NOTE**



- The ECoolPLANT software is available as a free download on the website **Fehler! Linkreferenz ungültig..** Alternatively, simply scan the QR code opposite.
- The appropriate operating manual for the ECoolPLANT software is available for downloading under **Fehler! Linkreferenz ungültig.**

**NOTE**

For a detailed description of the error messages and troubleshooting notes, see section "Error messages", Page 64.

## 5.5 Test mode

### DANGER

#### **Danger of fatal injury due to electric shock!**

Condensate may form increasingly on the cooling unit when the switch cabinet door is open and during extended test operation.

This may lead to an electrical hazard in the vicinity of live parts.

- The test mode may only be activated by authorized specialists with electrical training.
- The unit may only be operated in test mode under supervision.

The test mode triggers the cooling unit to commence unconditional cooling for 90 s.

This means that the internal and external fans as well as the compressor are switched on. Errors and alarms have priority, but the "door contact open" error is ignored.

Normal operation is automatically resumed after 90 s.

#### **Requirements**

- The cooling unit is ready for operation.
- The LED light of the control unit lights green.

#### **Procedure**

1. Press the **Back + Set** buttons simultaneously for at least 5 s.
  - Fans and compressors start up.
2. The countdown timer is shown in the display (alternating with the ACTUAL temperature):



- ⇒ The test mode is active. The cooling unit resumes normal operation after 90 s. If the **Back + Set** button combination is pressed again during the countdown, the test mode starts again with the countdown of 90 seconds.

The test mode may be started as often as necessary.

## 6 Service and maintenance

### 6.1 Safety information

#### DANGER

##### **Danger of fatal injury due to electric shock!**

Parts may be under voltage when the unit is opened and can cause an electric shock if touched.

Observe the following points when working on the open unit:

- Work on the electrical system may only be carried out by authorized electricians.
- Before commencing work on the electrical system, switch off the power supply, check that no voltage is applied and secure against being switched back on.
- Cordon off the working area and post a warning sign.
- The electrical connection must be made according to nationally valid regulations.

#### WARNING

##### **Danger due to faulty maintenance/repair!**

A higher risk of injury exists for persons who carry out work for which they are neither qualified nor have been instructed.

- The unit may only be maintained/repared by persons who are familiar with the procedure and aware of the risks as well as having the necessary qualifications.
- Always switch off the disconnecter/contactator prior to starting maintenance work.
- Wait for the end of the 10-minute discharge phase of the electrical components. The unit should only be opened afterwards.
- Ensure that the fans are in the idle position and do not rotate.
- Check the unit for proper and safe operation after replacing defective parts or components.
- Check the full performance of the condensate drain following each maintenance operation or replacement of spare parts.

#### CAUTION

##### **Risk of cutting and injury!**

Risk of cutting and injury due to production-related, sharp sheet metal edges on the unit.

- Use personal protective equipment (cut-proof gloves).
- Handle with care.

#### ATTENTION

##### **Damage to the unit!**

Damage to the unit due to irregular maintenance. Non-compliance with the recommended maintenance work reduces the cooling capacity of the cooling unit and may lead to reduced machine availability.

- Regularly carry out maintenance work in accordance with the maintenance checklist.
- Only units serviced in accordance with specifications are covered by the warranty.

#### ATTENTION

##### **Damage to the unit!**

Damage to the unit due to spare parts from other manufacturers.

- Only original parts are subject to quality control by the manufacturer.
- Only use original manufacturer parts to ensure safe and reliable operation.

## 6.2 General

The refrigeration circuit is a maintenance-free, hermetically sealed system.  
The units are 100%-tested at the factory.

### **Manufacturer recommendation to the owner for maintenance work:**

- Perform maintenance work regularly every 12 months according to the maintenance checklist, see section "Maintenance schedule", Page 57.
  - Shorter maintenance intervals are required for air/water heat exchangers that cool in ambient air containing oil and dust. A shorter guide value of two to six months applies between the maintenance intervals.
- The functions of the Pfannenberg filters are optimally adapted to the cooling units. Therefore, the use of Pfannenberg filters has positive effects on the scope of the maintenance work.



### 6.3 Maintenance schedule

<b>Maintenance interval:</b>	Perform every twelve months. Every two to six months, in ambient air containing oil and dust.			
<b>Type:</b>	_____			
<b>Serial number:</b>	_____			
<b>Date of maintenance:</b>	_____			
<b>Executing specialist (name):</b>	_____			
	<b>Unit area designation / necessary maintenance work</b>	<b>Visual inspection</b>	<b>To do</b>	<b>Result</b>
<b>1</b>	<b>Aggregate prior to maintenance</b>			
1.1	General visual inspection of the aggregate			
1.2	Inspection for corrosion damage			
<b>2</b>	<b>Refrigeration circuit</b>			
2.1	Check refrigerant carrying parts for oil traces			
2.2	Check refrigerant carrying parts for leaks			
2.3	Check electrical connections for damage			
<b>3</b>	<b>Condenser/heat exchanger</b>			
3.1	Check pipe assembly for deposits			
3.2	Inspection for general corrosion damage			
3.3	Check, clean and align blades*			
<b>4</b>	<b>Evaporator/heat exchanger</b>			
4.1	Check pipe assembly for deposits			
4.2	Inspection for general corrosion damage			
4.3	Check, clean and align blades*			
<b>5</b>	<b>Condenser fan (external)</b>			
5.1	Check holder for loose parts			
5.2	Check electrical connections for damages			
5.3	Check motor bearing for noise			
5.4	Check drive for signs of overheating			
5.5	Clean fan*			
<b>6</b>	<b>Evaporator fan (internal)</b>			
6.1	Check holder for loose parts			
6.2	Check electrical connections for damages			
6.3	Check motor bearing for noise			
6.4	Check drive for signs of overheating			
6.5	Clean fan*			
<b>7</b>	<b>Pre-filter</b>			
7.1	Change filter mat*			
7.2	Clean filter mat*			

Tab. 15: Cooling unit maintenance schedule

\* Maintenance intervals more frequent, depending on the level of contamination.

## 6.4 Maintenance work

### 6.4.1 Cleaning

#### **WARNING**

##### **Danger of accident and component damage**

Danger of accident and component damage due to improper cleaning.

Cleaning the cooling units using water jets, steam jet cleaners or high-pressure cleaners or sharp objects may damage the electrical and electronic components. Malfunctions may cause accidents.

- Do not clean with a water jet, high-pressure cleaner or flammable cleaning agents.
- Protect electrical components against moisture penetration.
- Do not use pointed or sharp-edged objects when cleaning the blades. They must not be compressed or damaged.

The frequency of cleaning intervals depends on the respective operating conditions. Perform the following cleaning operations regularly to ensure safe and reliable operation of the cooling units:

- Clean the heat exchangers of dust or ambient residues.
- Regularly check the condensate drain.

### 6.4.1.1 Removing/assembling the unit cover

#### **⚠ CAUTION**

##### **Danger of crushing when removing/assembling the unit cover**

Hands and other body parts may be crushed when removing and reinserting the unit cover.

- Do not place any body parts between the frame, springs and the unit cut-out.
- Work carefully and wear cut-proof gloves.

#### Removing the unit cover

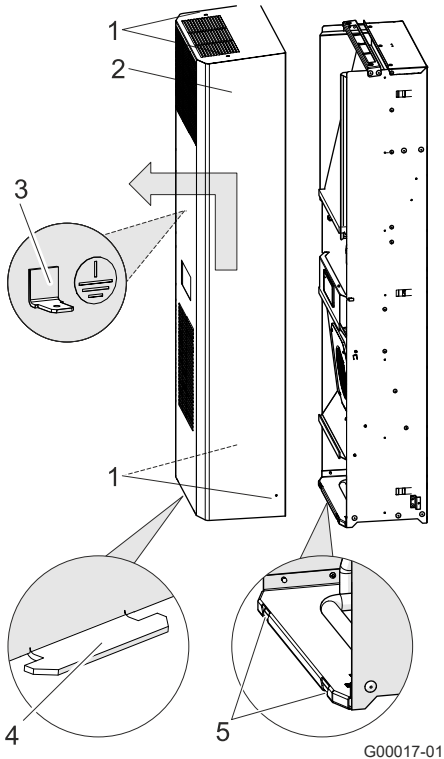

Fig. 25: Removing the unit cover

#### Prerequisite

**⚠ DANGER** – Danger to life due to electric shock. Make sure that the unit is voltage-free.

Wait for a discharge phase of 10 minutes for the electrical components. The unit should only be opened afterwards.

#### Procedure

1. Remove the four screws (1) of the unit cover (2).
  2. Tip the unit cover forward by 20°.
 

**ATTENTION** – Damage to the unit.  
Always pull off the earthing cable (3) from the inside of the unit cover before removing the unit cover.
  3. Lift the unit cover (2) about 15 mm and pull the lugs (4) out of the slits (5) in the floor plate.
- ⇒ The unit cover is removed.

### Assembling the unit cover

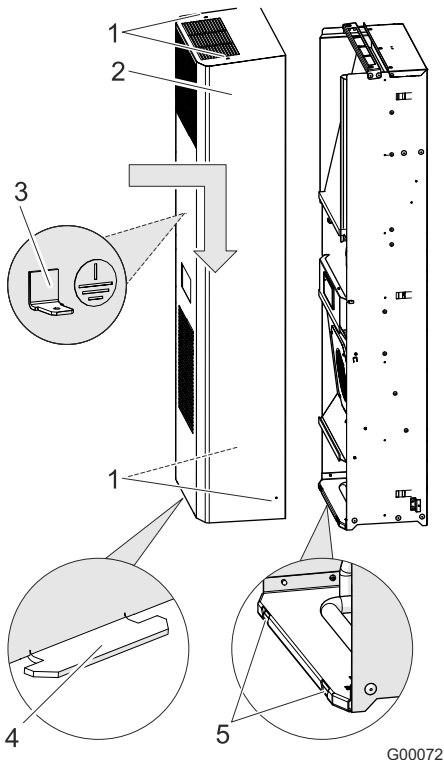

Fig. 26: Assembling the unit cover

#### Prerequisite

**⚠ DANGER** – Danger to life due to electric shock. Make sure that the unit is voltage-free.

Wait for a discharge phase of 10 minutes for the electrical components. The unit should only be opened afterwards.

#### Procedure

1. Plug the earthing cable (3) into the inside of the unit cover (2).
2. Push the lugs (4) of the unit cover into the slits (5) in the floor plate.
3. Plug the earthing cable (3) into the inside of the unit cover.
4. Close the unit cover again.

**⚠ ATTENTION** – Damage to the unit.

When closing the unit cover, make sure that the earthing cable (3) is not trapped.

5. Fasten the unit cover with the four screws (1).
- ⇒ The unit cover is assembled.

### 6.4.1.2 Cleaning the heat exchanger

#### ATTENTION

##### Damage to components

Damage to the heat exchanger fins due to incorrect cleaning.

- Clean the heat exchanger fins with a soft brush, compressed air or a vacuum cleaner with a brush attachment.

#### NOTE

The time intervals for cleaning depend strongly on the contamination of the ambient air.

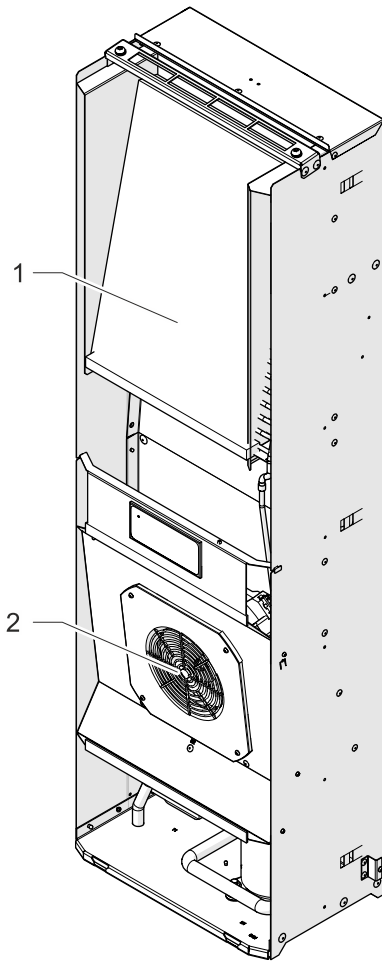

G00026-01

Fig. 27: Cleaning the heat exchanger

#### Prerequisites

**⚠ DANGER** – Danger to life due to electric shock. Make sure that the unit is voltage-free.

- The unit cover is removed, see chapter "Removing/assembling the unit cover", Page 59.

#### Required tools and materials

- Soft brush
- Vacuum cleaner with brush attachment or compressed air cleaner
- Fin comb

#### Procedure

1. Clean heat exchanger fins (1) and condenser fan (2) with a soft brush, with compressed air or with a vacuum cleaner with brush attachment.

**⚠ CAUTION** – risk of injury. Do not touch the sharp heat exchanger fins.

**⚠ CAUTION** – dust development when cleaning with compressed air. Wear eye, mouth and nose protection when cleaning with compressed air.

2. Check heat exchanger for bent fins; straighten fins with fin comb.
  3. Refit the unit cover.
  4. Check that the cooling unit works properly and safely after cleaning.
- ⇒ The heat exchanger is cleaned.

### 6.4.1.3 Cleaning filter mats

#### ATTENTION

##### Damage to components

Damage to the filter mats due to improper cleaning.

- Avoid high-pressure water jets.
- Do not wring out filter mats.
- Replace oily or greasy filter mats immediately.

#### NOTE

The time intervals for cleaning or replacing the filter mats depend strongly on the contamination of the ambient air.

#### Requirements

- Unit is switched off.

#### Required tools and materials

- Brush
- Water below 40 °C
- Fine detergent
- Vacuum cleaner or compressed air cleaner

#### Procedure

In cooling units with pre-filters, clean the filter mat at regular intervals.

1. Unhook the filter adapter from the cooling unit.
  2. Remove the filter mat and clean it or, if it can no longer be cleaned, replace it.
    - Wash out the filter mat with water up to 40 °C and commercially available fine detergent.
    - Knock off, suck off or blow off dry contamination from the filter mat.
  3. Insert the cleaned filter mat into the filter adapter.
  4. Hang the cooling unit back onto the cooling unit.
  5. Check that the cooling unit works properly and safely after cleaning.
- ⇒ The cooling unit is cleaned.

## 7 Rectification of operating faults

### 7.1 General

#### NOTE

Flashing of the red LED light on the controller card is **not** a fault indication or error message.  
 The red LED light indicates that the cooling unit is carrying voltage.

Fault	Possible causes	Remedial measures
Unit does not cool, evaporator fan (internal) running	Temperature setting too high.	Check temperature setting.
Unit does not cool sufficiently	Application limits exceeded.	Check ambient air temperature and internal load.
	Low refrigerant level.	Call authorized specialist personnel, check the unit for leaks.
	Heat exchanger contaminated.	Cleaning the heat exchanger.
	Evaporator fan (internal) defective. Condenser fan (external) defective.	Call authorized specialist personnel; change fan.
	Air circulation in switch cabinet disrupted.	Check installations and circulation channels in the switch cabinet. Check the air inflow and outflow from the cooling unit into the inlet and outlet openings of the switch cabinet. Check DIP-switch and cable connections.
Unit only cools sometimes.	DIP-switch set incorrectly or defective.	Set higher temperature on the DIP-switch.
Condensate formation in the switch cabinet	Blow-out temperature too low.	Close switch cabinet door.
	Switch cabinet is not sufficiently sealed.	Rectify any leaky areas or seals on the switch cabinet. Check temperature setting.
Condensate does not drain	Condensate drain is blocked.	Clean the condensate drain. Check whether the condensate drain hose is free of kinks and installed on a gradient.
Condensate drips from the unit.	Switch cabinet is not sufficiently sealed.	Rectify any leaky areas or seals on the switch cabinet.
	Condensate drain is blocked.	Clean the condensate drain. Check whether the condensate drain hose is free of kinks and installed on a gradient.

Tab. 16: General operating faults

**7.1.1 Error messages**

The error numbers are not displayed in units with Standard Controllers. Using the ECoolPLANT software, it is possible to read out the error numbers on the computer.

**NOTE**

Flashing of the red LED light on the controller card is **not** a fault indication or error message.  
 The red LED light indicates that the cooling unit is carrying voltage.

Error no.	Fault/unit behavior	Possible causes	Remedial measures
Er00	LED:	flashes	<b>Door contact:</b> The door contact circuit is interrupted.  Close the door. Connect the door contact switch. Bridge the door contact. Check wiring.
	Compressor:	OFF	
	Evaporator fan (internal):	OFF	
	Condenser fan (external):	OFF	
	Heating (external):	OFF	
	Fault signal contact::	closed	
Er01	LED:	flashes	<b>Pressostat tripped:</b> Too high pressure in the refrigeration circuit. The cooling unit cannot dissipate the heat from the refrigeration circuit.  Let the unit cool down. Clean the fins of the heat exchanger (internal/external). Check the function of the condenser fan (external).
	Compressor:	OFF	
	Evaporator fan (internal):	ON	
	Condenser fan (external):	OFF	
	Heating (external):	OFF	
	Fault signal contact::	Open	
Er04	LED:	flashes	<b>Phase sequence/phase failure:</b> Failure of at least one phase or phase sequence is wrong (only in three-phase units with cam compressors).  Check field of rotation - (right-hand field of rotation is mandatory). All phases must carry rated voltage.
	Compressor:	OFF	
	Evaporator fan (internal):	OFF	
	Condenser fan (external):	OFF	
	Heating (external):	OFF	
	Fault signal contact::	Open	
Er05	LED:	flashes	<b>Sensor 1 (TS1) defective.</b>  According to the unit type, replace sensor 1 (permanently soldered on the controller card) or the complete controller card.
	Compressor:	ON	
	Evaporator fan (internal):	ON	
	Condenser fan (external):	ON	
	Heating (external):	OFF	
	Fault signal contact::	Open	

Tab. 17: Possible error messages



Error no.	Fault/unit behavior	Possible causes	Remedial measures
Er06	LED:	flashes	<b>Sensor 1 Minimum:</b> Minimum value of the switch cabinet temperature "Lit" (display) is reached or exceeded.  Select a higher switch cabinet temperature setpoint. Check switch cabinet for leakages. Move components located in the vicinity of the air inlet and air outlet further away to prevent an air short-circuit. (The cold air is deflected directly to the air inlet by components.)
	Compressor:	OFF	
	Evaporator fan (internal):	ON	
	Condenser fan (external):	ON	
	Heating (external):	OFF	
	Fault signal contact::	Open	
Er07	LED:	flashes	<b>Sensor 1 Maximum:</b> Maximum value of the switch cabinet temperature "Lit" (display) is reached or exceeded. The cooling unit cannot cool the air in the switch cabinet sufficiently.  Check settings of the cooling unit. Clean the fins of the heat exchanger (internal/external). Check the function of the evaporator fan (external). Check the refrigeration circuit for spilled refrigerant or leakage. Install a cooling unit with a higher cooling capacity if necessary.
	Compressor:	ON	
	Evaporator fan (internal):	ON	
	Condenser fan (external):	ON	
	Heating (external):	OFF	
	Fault signal contact::	Open	
Er08	LED:	flashes	<b>Sensor 2 (TS2) defective.</b>  Replace sensor 2 according to the unit type. Sensor 2 is plugged to the card, not permanently soldered.
	Compressor:	ON	
	Evaporator fan (internal):	ON	
	Condenser fan (external):	ON	
	Heating (external):	OFF	
	Fault signal contact::	Open	

Tab. 17: Possible error messages (continued)

Error no.	Fault/unit behavior	Possible causes	Remedial measures
<b>Er 15</b>	LED: flashes	<b>Antifreeze (option):</b> Antifreeze-Sensor ≤ 1°C. Safety cut-out because the evaporator is threatening to ice up.	Restart operation after condensate has evaporated. A restart is only possible by disconnecting and reconnecting the mains voltage. No other reset is provided for safety reasons. Clean the fins of the heat exchanger (internal/external). Check switch cabinet for leakages. Select a higher switch cabinet temperature setpoint. Check the evaporator fan (internal) function.
	Compressor: OFF		
	Evaporator fan (internal): OFF		
	Condenser fan (external): OFF		
	Heating (external): OFF		
	Fault signal contact:: Open		
<b>Er 19</b>	LED: flashes	Sensor 5 (TS5) defective.	Replace sensor 5 or the controller card according to the unit type.
	Compressor: OFF		
	Evaporator fan (internal): OFF		
	Condenser fan (external): OFF		
	Heating (external): OFF		
	Fault signal contact:: Open		

Tab. 17: Possible error messages (continued)

7.1.2 System messages

Signal	Unit behavior	System information
En	LED:	lights
	Compressor:	OFF
	Evaporator fan (internal):	OFF
	Condenser fan (external):	OFF
	Heating (external):	OFF
	Fault signal contact::	closed
StUP	LED:	lights
	Compressor:	OFF
	Evaporator fan (internal):	OFF
	Condenser fan (external):	OFF
	Heating (external):	OFF
	Fault signal contact::	closed
StOP	LED:	lights
	Compressor:	OFF
	Evaporator fan (internal):	OFF
	Condenser fan (external):	OFF
	Heating (external):	OFF
	Fault signal contact::	closed

**Energy-saving mode active**

- Execution of the energy function, is activated in energy-saving mode.
- For details of the energy-saving mode, see section "Energy-saving mode", Page 21.

**Start-up mode**  
The cooling unit starts its operation

**Stop mode**  
Unit was stopped by:

- Opening the switch cabinet door.
- The cooling unit received a stop command, e.g. via the software application.

Tab. 18: Possible system messages

## 8 Decommissioning

### DANGER

#### **Danger of fatal injury due to electric shock!**

Parts may be under voltage when the unit is opened and can cause an electric shock if touched.

Observe the following points when working on the open unit:

- Work on the electrical system may only be carried out by authorized electricians.
- Before commencing work on the electrical system, switch off the power supply, check that no voltage is applied and secure against being switched back on.
- Cordon off the working area and post a warning sign.
- The electrical connection must be made according to nationally valid regulations.

### 8.1 Temporary decommissioning

#### WARNING

#### **Danger of injury from materials and substances**

Improper work on the unit or opening of the refrigeration circuit can be harmful to the health.

- Always ensure that the power supply is disconnected prior to working on the unit.
- Only properly qualified personnel should dispose of the unit in accordance with applicable environmental regulations.

The power supply must be interrupted if the cooling unit is not required for an extended period of time.

- Ensure that improper commissioning by third parties is ruled out

### 8.2 Final decommissioning

#### CAUTION

#### **Danger of crushing when decommissioning the unit**

Hands and other body parts may be crushed when removing units.

- Do not place any body parts between the frame, springs and the unit cut-out.

When cooling units are ultimately decommissioned or disposed of, observe the notes in section "Dismantling and disposal", Page 69!

#### **NOTE**

Old units are also professionally disposed of by Pfannenberg. Delivery to one of our manufacturing facilities shall be free of charge.

## 9 Dismantling and disposal

The unit must be dismantled and disposed of in an environmentally friendly way at the end of its useful life.

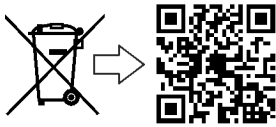

Units marked by the symbol opposite may not be disposed of with unsorted domestic waste. They must be taken to a separate electrical and electronic waste collection depot. For further information about disposal, scan the QR code or call [www.pfannenberg.com/disposal](http://www.pfannenberg.com/disposal).

### 9.1 Safety information

All work may only be performed by persons with certified qualifications under consideration of:

- the minimum qualification
- this manual
- the valid local regulations and laws
- company-internal work, operation and safety regulations

Use the necessary personal protective equipment for the respective activity for all work.

#### DANGER

##### **Danger of fatal injury due to electric shock!**

Parts may be under voltage when the unit is opened and can cause an electric shock if touched.

Observe the following points when working on the open unit:

- Work on the electrical system may only be carried out by authorized electricians.
- Before commencing work on the electrical system, switch off the power supply, check that no voltage is applied and secure against being switched back on.
- Cordon off the working area and post a warning sign.
- The electrical connection must be made according to nationally valid regulations.

#### CAUTION

##### **Risk of cutting and injury!**

Risk of cutting and injury due to production-related, sharp sheet metal edges on the unit.

- Use personal protective equipment (cut-proof gloves).
- Handle with care.

#### CAUTION

##### **Risk of injury due to improper working!**

Risk of injury due to improper working on the refrigeration unit.

- The refrigeration unit may only be dismantled by specialized refrigeration companies.

**ATTENTION****Hazards for the environment**

Refrigerants are harmful to the environment as soon as they escape into the atmosphere.

- Only have work on the refrigeration unit carried out by experts in accordance with the chemicals climate protection directive.
- Do not damage refrigerant lines.
- Pass on refrigerants for professional treatment.

**NOTE**

Dismantling and disposal are to be carried out by the owner or persons authorized by him.

Contact the local authorities or special disposal companies for information on issues of environmentally friendly disposal.

**9.2 Dismantling****Requirements**

**⚠ DANGER** – Danger to life due to electric shock. Make sure that the unit is voltage-free.

**Procedure**

1. Switch off the unit, secure against switching back on and wait until all parts have a temperature below 40 °C.
2. Physically disconnect all energy and media supplies from the unit, discharge stored residual energy.
3. Clean dirt and contamination from the unit.
4. Remove operating and auxiliary materials and dispose of them in an environmentally friendly way.
5. Dismantle the unit into the different separable materials.
  - Observe the valid work safety and environmental protection regulations.

### 9.3 Disposal

#### NOTE

---

Old units are also professionally disposed of by Pfannenberg. Delivery to one of our manufacturing facilities shall be free of charge.

---

Dismantled components should be recycled unless return or disposal agreements have been made:

- Scrap metals
- Hand over plastic elements for recycling
- Dispose of other parts sorted according to their material properties

#### ATTENTION

---

##### Hazards for the environment

Improper disposal of chemicals (e.g. additives) can cause environmental pollution.

- Chemicals must not be thrown in with the domestic trash and must not be allowed to get into the sewer system or ground.
  - Wear appropriate protective clothing (gloves, eye protection, etc.) for disposal.
  - Dispose of the used chemicals (as special waste if necessary) and pass on for recycling separately.
  - Refrigerants may not escape into the atmosphere. Pass on refrigerants for professional treatment.
  - Work on the refrigeration circuit may only be carried out by experts in accordance with the chemicals climate protection directive.
  - Observe safety data sheets as well as valid national and local regulations.
- 

The components of the plant or the unit basically consist of the following materials:

- plastic
- non-ferrous metals
- stainless steel
- steel and aluminum parts
- electronic sub-assemblies
- refrigerants in the refrigeration circuit (type and amount, see section "Refrigeration circuit", Page 26)

## 10 Spare parts and accessories

### NOTE

- Always state the Pfannenberg part number when ordering spare parts and accessories.
- The Pfannenberg part number for the controller is on the controller transformer.

No.	Designation	No.	Designation
18811100065	Evaporator fan (internal)	18811100065	Condenser fan (external)
18810200156	Unit cover DTI 62/63/64/6501 RAL	18810200158	Unit cover DTS 62/6301 RAL
18314000100	Condensate collection bottle	18810000001	Indicator unit Standard Controller (SC)
18310000151	Filter adapter	18310000004	USB adapter
18300000148	Bellows filter	18300000147	Felt filter
—	—	18300000149	Metal filter

Tab. 19: Spare parts and accessories list



## 11 Index

<b>A</b>	
About this document	
Handling instructions.....	8
Accessories .....	72
Adapting the mains voltage .....	48
Assembly	
DTI cooling unit (installation).....	37
DTS cooling unit (side attachment).....	35
Profile seal.....	36
<b>C</b>	
Cable cross-section.....	40
Cleaning .....	58
Cleaning filter mats.....	62
Cleaning the heat exchanger.....	61
Collective fault signal.....	45
<b>D</b>	
Decommissioning.....	68
Dimensions .....	28
Dismantling .....	69
Disposal.....	69
Door contact switch.....	44
<b>E</b>	
ECoolPLANT.....	53
Electrical connection .....	40
Circuit diagram.....	41
Collective fault signal .....	45
Connection compartment.....	42
Equipotential bonding.....	48
Mains connection.....	46
Electrical data .....	27
Energy-saving mode .....	21
Equipotential bonding.....	48
Error messages.....	64
<b>F</b>	
Filter adapter.....	14
Filter mat.....	14
Functional description	
Air circuit.....	15
<b>M</b>	
Mains connection .....	46
Maintenance schedule.....	57
Maintenance work .....	58
Cleaning .....	58
Menu overview.....	51
Misuse .....	10
Multi-Controller (MC).....	16, 43
Energy-saving mode.....	21
Menu overview.....	51
Menus .....	50
Multimaster function.....	22
Operating/display elements.....	16
Operation.....	50
Password.....	50
System information .....	17
Multimaster Control .....	43
Multimaster function .....	22
<b>O</b>	
Operating faults.....	63
Operation .....	52
Test mode .....	54
Order options .....	13
<b>R</b>	
Refrigeration circuit .....	18, 26
Removing the unit cover .....	59
<b>S</b>	
Safety information .....	29, 55, 69
Service interface .....	53
Signs .....	25
Spare parts .....	72
Storage .....	33
Strain relief.....	40
Symbols.....	25
System messages.....	67
<b>T</b>	
Technical data.....	26
Dimensions.....	28
Electrical data .....	27
Other data .....	28
Terms of warranty .....	11
Test mode.....	54
Transport .....	30
Crane transport.....	32
Type plate .....	23
<b>U</b>	
Unpacking.....	33
USB adapter .....	53

**Exclusion of liability:**

All the contained information has been carefully checked.

However, we shall assume no liability with regard to the completeness and accuracy of the information.

**Company details:**

Pfannenberg GmbH  
Werner-Witt-Strasse 1  
21035 Hamburg  
Tel. +49 40 734 12-0  
[www.pfannenberg.com](http://www.pfannenberg.com)