

Operating manual

Roof-mounted cooling units

DTT series 6801

Standard Controller (SC) – 400 / 460 V 3~

Version 1.0, September 2017



Preface

Skills and information provided in the present ORIGINAL OPERATING MANUAL are required for assembly and safe operation of Pfannenberg cooling units.

The information is presented in a brief, clearly arranged format. The chapters are numbered throughout. If you have the operating manual in digital format, the links are **interactive**.

Various unit types are documented in this operating manual.

Pfannenberg cooling units are subject to continuous improvement. Please understand that we must reserve the right to changes in design, equipment and technology. For this reason, no claims to specific features of the unit can be derived from the content of this operating manual.

Safety instructions and markings



Identifies an exceptionally dangerous situation. Severe, irreversible injuries or death will occur if this notice is not observed.



Identifies an exceptionally dangerous situation in connection with electrical voltage. Severe, irreversible injuries or death will occur if this notice is not observed.



Identifies an exceptionally dangerous situation. Severe, irreversible or deadly injuries will occur if this notice is not observed.



Identifies a dangerous situation. Minor or moderate injuries will occur if this notice is not observed.

☒ before notices and explanations.

* Legend notice

⇒ Arranged before results of actions.

Table of contents

1	Intended use	5
1.1	General overview	5
1.2	Permissible usage conditions	5
1.3	Duty of the operator	5
2	Unit description	6
2.1	Description of use	6
2.2	Scope of delivery	6
2.3	Order options	6
2.4	Functional description	7
2.4.1	Air flow functional principle	7
2.4.2	Optional quick-release frame	7
2.4.3	Optional flat channel system	8
2.4.4	Controller	10
2.4.5	DIP switch	10
2.4.6	Refrigerant circuit functional principle	11
2.4.7	Safety concept	11
2.4.8	Condensate management	12
2.5	Type plate	13
2.6	Technical data	14
2.6.1	Refrigeration data	14
2.6.2	Electrical data	14
2.6.3	Dimensions	14
2.6.4	Other unit data	14
3	Assembly and initial commissioning	15
3.1	Transport	15
3.2	Storage	15
3.3	Unpacking	16
3.4	Assembly	16
3.4.1	General assembly requirements	17
3.4.2	DTT cooling unit assembly (installation)	18
3.4.3	Mounting M8 jack rings	19
3.4.4	Install flat seal and assemble	20
3.4.5	Switch cabinet assembly	21
3.4.6	Assembly with quick-release frame	22
3.5	Electrical connection	25
3.5.1	Electrical circuit diagram - Standard controller (SC)	25
3.5.2	DIP switch	26
3.5.3	Door contact switch	27
3.5.4	Mains supply connection	27
3.5.5	Adapting the upstream fuse /transformer options	29
3.5.6	Collective fault signal	29

4	Operation	30
4.1	General functions.....	30
4.2	Operation of the cooling unit.....	31
4.3	Service interface	32
4.4	Error messages.....	33
5	Service and Maintenance	35
5.1.	General cleaning.....	35
5.2	Cleaning the cooling unit - Unit cover removal.....	36
5.3	Cooling unit and filter mat cleaning tasks	36
5.4	Maintenance	37
5.5	Maintenance checklist template.....	38
5.6	Decommissioning	39
6	Troubleshooting.....	40
7	Spare part orders / accessory orders	41
8	Terms of warranty	41

1 Intended use

1.1 General overview

Die Pfannenberg roof-mounted cooling units of the DTT series DTT are stationary cooling units for the dissipation of heat from switch cabinets. The DTT cooling units are mounted on the switch cabinet roof.

The cooling units have different cooling outputs. For exact power specifications, see [Technical data](#).

The cooling units have cut-out compatibility with air/air heat exchangers and air/water heat exchangers. Use of aluminum filters, fleece filters and fluted filters is possible with an additional adapter.

The cooling units are available with different controllers. Cooling units are available with a standard controller (SC) or a multicontroller (MC). These controllers are regulating units for the adjustment of refrigeration functions and operating data. They also enable readouts of system messages and diagnostic data. The [multicontroller](#) (MC) is also equipped with a multimaster function and energy saving mode.

☒ For detailed specifications for the controller, see [Technical data](#), and operation [standard](#) controller.

All Pfannenberg cooling units are ROHS-compliant and free from:

- silicone connections
- PCT, asbestos, formaldehyde, cadmium
- moisture-impairing substances

☒ All cooling units are factory-tested for conformance to pressure tightness standard UVV-BGV D4.

☒ Comprehensive safety testing is carried out in the factory prior to delivery. The proper and safe condition of the cooling units is checked. The operator's duty in according to Accident Prevention Regulation BGB A2, §5 (4) for the electrical safety testing during the initial commissioning does not apply.

1.2 Permissible usage conditions

- The permissible ambient air temperature range of DTT cooling units is +15°C (+59°F) to +55°C (+131°F).
- The permissible storage temperature of DTT cooling units must not exceed +70 °C (+158°F).

1.3 Duty of the operator

The operator must ensure that the cooling units are used exclusively as intended and dangers of all types to the life and limb of users or third parties are avoided. In addition, accident prevention regulations and recognized safety rules are observed.

The operator must ensure that all users have read and understood this operating manual.

Non-observance of this operating manual will void the warranty. The same applies if improper work has been carried out on the unit by the customer and/or third parties without the approval of the manufacturer.

2 Unit description

2.1 Description of use

The Pfannenberg roof-mounted cooling units of the DTT series are designed for the dissipation of heat from switch cabinet. The innovative configuration of the climate control circuits prevents cold bridging in the switch cabinet and the risk of condensate accumulating in the switch cabinet is prevented.

The evaporator unit in the upper section of the cooling unit guarantees problem-free condensate water drainage without switch cabinet contact.

☒ The cooling units operate with refrigerant rated for very low flammability and which is not harmful for the ozone layer.

2.2 Scope of delivery

The shipment consists of the following contents:

- DTT cooling unit
- Cooling unit quick guide
- Accessory kit: Appropriate seal, fastening material, electrical plug connector, etc. for the specific unit type
- Special accessories, if applicable

2.3 Order options



WARNING

Spare parts from third-party manufacturers can damage the unit

- Only original parts are subject to the manufacturer's quality control.
- Only use specially harmonized manufacturer parts for safe and reliable operation.

☒ For Pfannenberg spare part numbers, see [ordering spare parts and accessory parts](#).

There is an optional expansion with a filter adapter for various filter mats (fleece filters, fluted filters and metal filters).

DTT cooling units are also available with the optional quick-release frame. It makes replacement of cooling units convenient and easy. The cooling units are available in different sizes.

☒ For Pfannenberg part numbers for all accessory orders, see [ordering spare parts and accessory parts](#).



WARNING

Danger due to impermissible use of units

Inappropriate use of the units can cause severe accidents.

- Cooling units must only be used in stationary operation.

The DTT cooling units are only approved for stationary operation. As cooling units with protection rating IP 54, the cooling units are essentially dust-protected. Limitation: Dust can penetrate after continuous exposure. The cooling unit are resistant to spray water, but not a constant water jet.

2.4 Functional description

2.4.1 Air flow functional principle

! CAUTION

Danger due to the release of very warm air

The air outlet can become very warm depending on the ambient temperature.

- Keep body parts away from the air outlet.

☒ For the ambient temperature and air outlet ratio, see [Technical data](#).

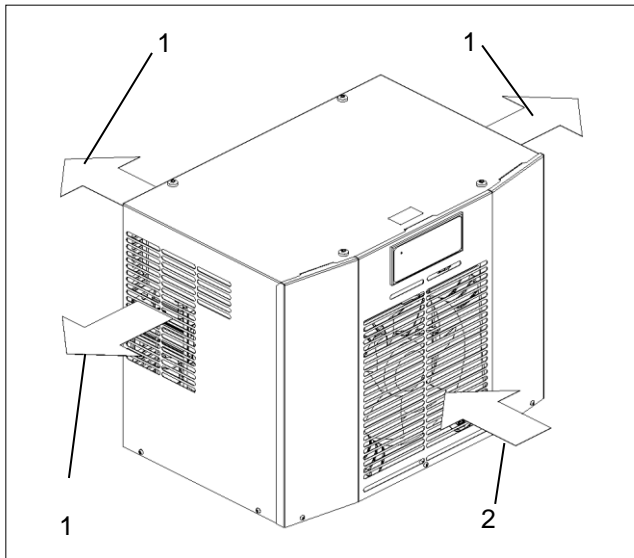

Figure 1 - Air flow principle front view

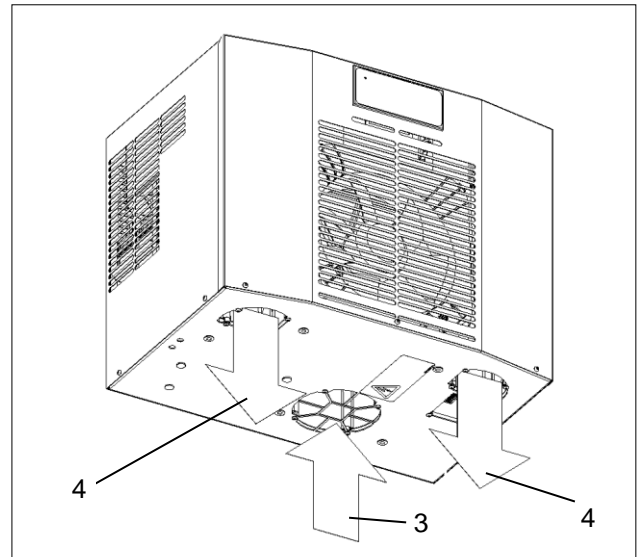

Figure 2 - Air flow principle bottom view

Item	Designation	Item	Designation
1	Ambient air outlet	3	Warm air inlet
2	Ambient air inlet	4	Cold air outlet

2.4.2 Optional quick-release frame

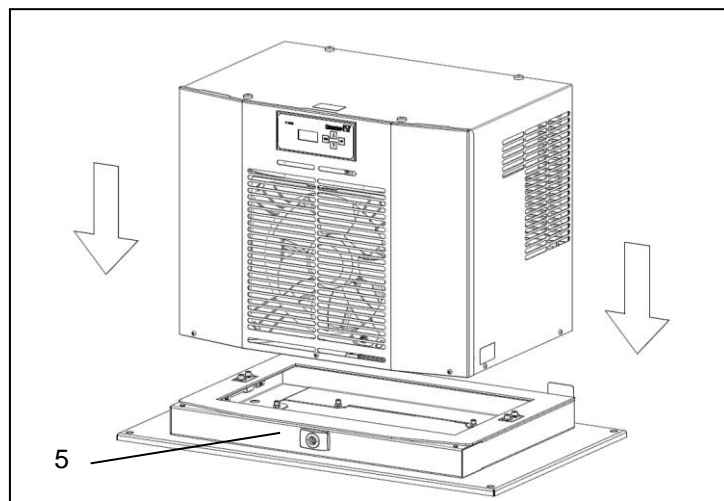

Figure 3 - Quick-release frame

DTT cooling units with quick-release frame (5) can be installed quickly and easily. The flexibility makes replacement of cooling units convenient and easy. A switch cabinet opening is not necessary.

2.4.3 Optional flat channel system

WARNING

Condensate water in the switch cabinet can cause short-circuits

Condensate water can accumulate on the air duct system.

- Check the switch cabinet regularly for condensate water on the air duct system.
- In case of damage, shut down the unit immediately and notify your supervisor.

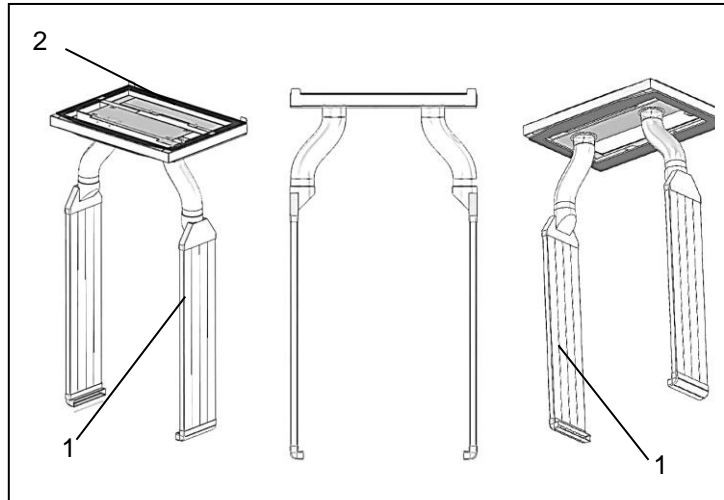

Figure4 – Flat channel system

The flat channel system (1) supports the air distribution in confined switch cabinets. It assures optimal cooling unit performance with adapted power consumption. The flat channel system (1) is used with a PAD frame (2).

☒ Three different PAD channel systems are provided for the flat channel system:

- DTT cooling units 6101/6201 size 1 (500 W / 1000 W): PAD single-channel system (3) with PAD single-channel frame (4).

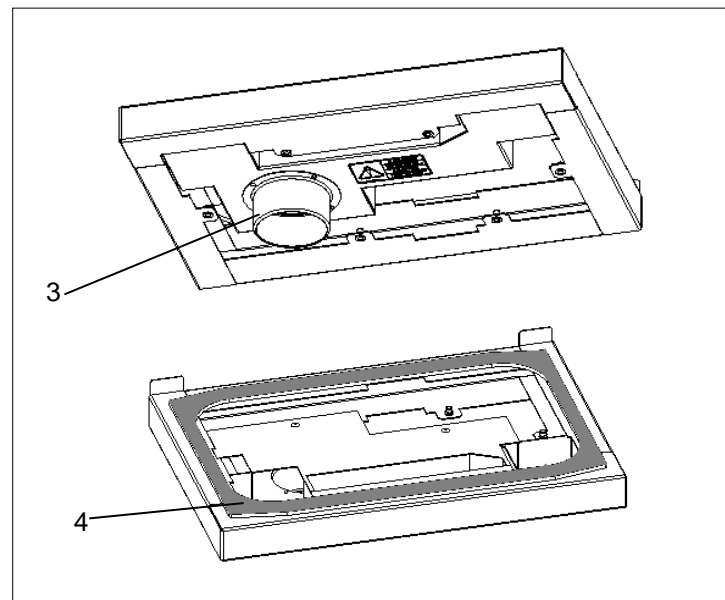

Figure5 - PAD single-channel system, DTT cooling units 6101/6201

☒ Three different PAD channel systems are provided for the flat channel system:

- DTT cooling units 6301/6401 size 2 (1500 W / 4000 W): PAD two-channel system* (5) with PAD two-channel frame (6).

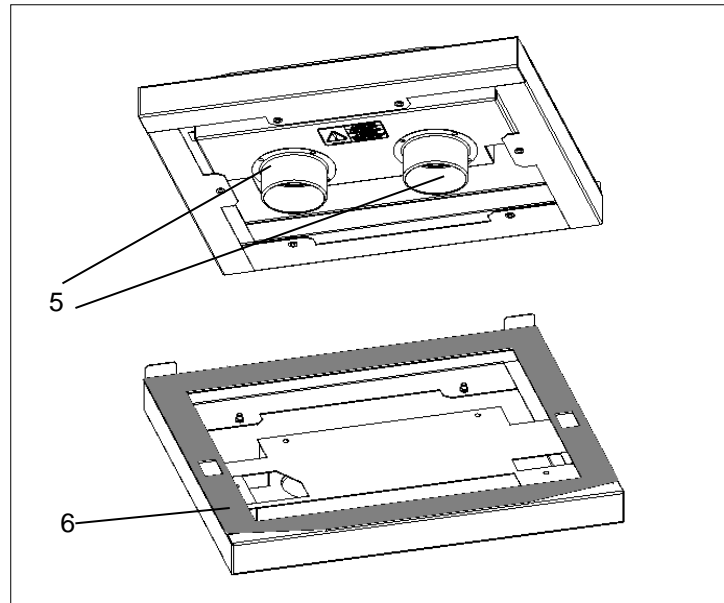

Figure6 - PAD two-channel system*, DTT cooling units 6301/6401

- DTT cooling units 6601/6801 size 3 (1500 W / 4000 W): PAD two-channel system* (7) with PAD two-channel frame (8).

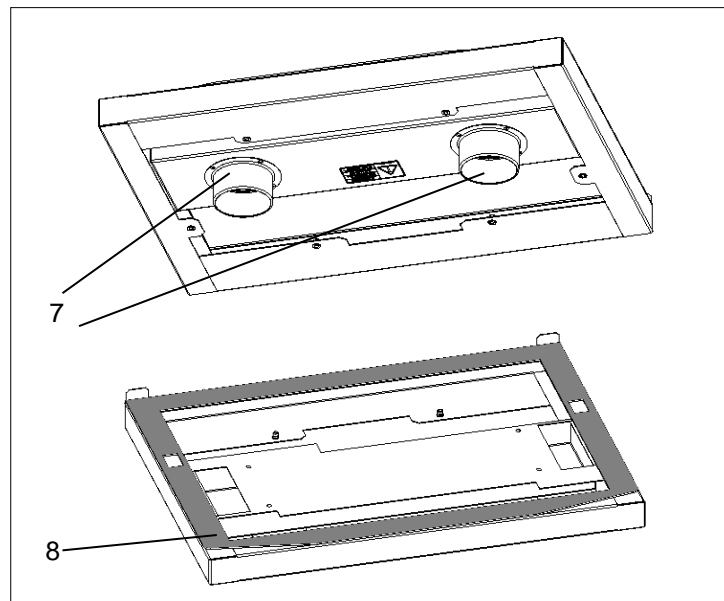

Figure7 - PAD two-channel system*, DTT cooling units 6601/6801

The DTT cooling units require the following PAD frames and the following PAD air channel system:

No.	Designation	No.	Designation
1831500005	DTT 6101/6201 PAD frame	1831500000	DTT 6301/6401 PAD frame
1831500001	DTT 6601/6801 PAD frame	1831500001	PAD air channel system*

* The PAD two-channel system (5/7) necessitates use of two PAD air channel systems.

2.4.4 Controller

Controllers are regulating units for the adjustment of refrigeration functions and operating data. They enable readouts of system messages and diagnostic data. The controllers have a service interface which enables various configurations. There is also a connection for collective fault indications.

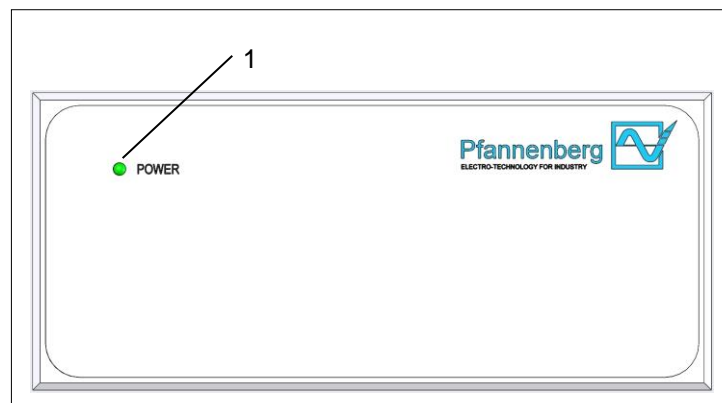

Figure 8 – Standard controller (SC) operating display

Cooling units with a standard controller (SC) have a display unit with a green LED light (1). The display unit is located on the unit cover. Permanent illumination of the green LED light (1) while the mains voltage is connected indicates fault-free operation. The LED light (1) begins to blink in case of an operational fault or a malfunction. For detailed information about the error messages, see [Error messages](#).

2.4.5 DIP switch

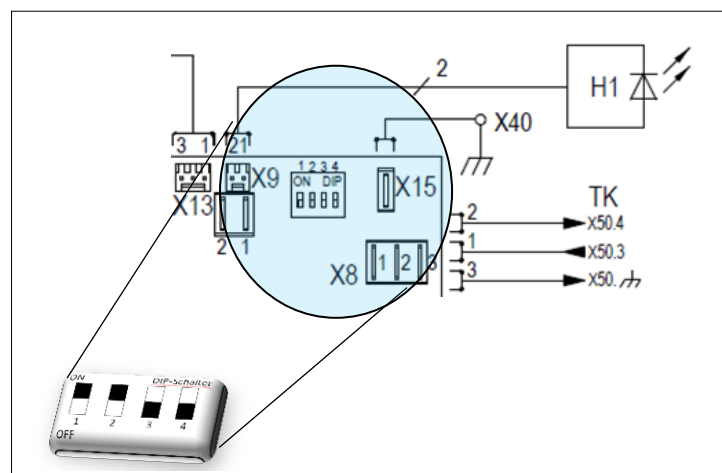

Figure 9 – DIP switch

The DIP switch on the control circuit board enables regulation and control of setpoints and limit values for temperatures; see [DIP switch](#).

☒ Position 4 on the DIP switch controls the adjustment of the temperature unit.

Optional control °C to °F (OFF = °C / ON = °F).

☒ Activation and deactivation of cooling units fixes the changes on the DIP switch. The settings of the DIP switch are made at the time of commissioning.

The following values are set in the condition as supplied from the factory:

- The switch cabinet temperature setpoint is 35°C.
- The maximum switch cabinet temperature is 50°C.

2.4.6 Refrigerant circuit functional principle

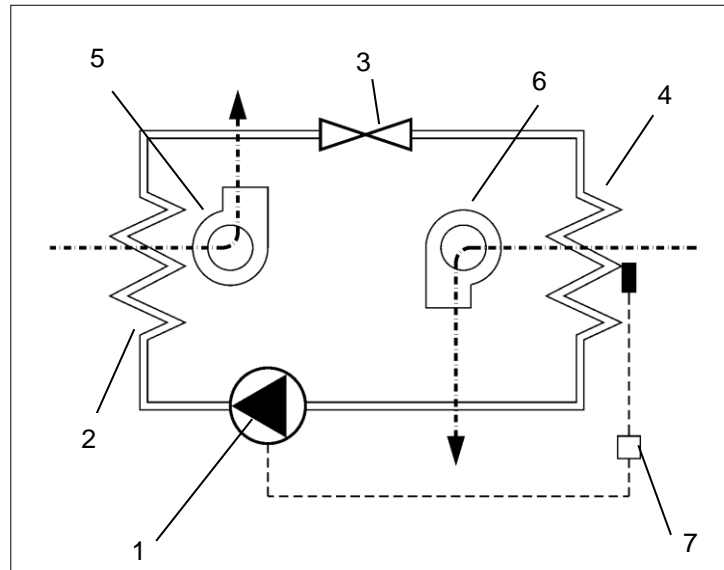

Figure 10 - Refrigerant circuit

Item	Designation	Item	Designation
1	Compressor	2	Liquefier
3	Expansion valve	4	Evaporator
5	Condenser fan (external)	6	Evaporator fan (internal)
7	Electronic control with temperature sensor		

The cooling units are comprised of various components; see the figure Refrigerant circuit.

- The compressor (1) compresses the refrigerant under high pressure. The temperature increases.
- This heat is released to the ambient air in the condenser (2). The refrigerant liquefies.
- The condenser fan (5) draws room air through the condenser (2) and releases it to the environment.
- A pressure drop occurs when the refrigerant passes through the expansion valve (3).
- Inside the evaporator (4), the refrigerant absorbs heat from the air inside the switch cabinet and evaporates. The air inside the switch cabinet is cooled and dehumidified.
- The evaporator fan (6) draws the air from inside the switch cabinet out through the evaporator (4) and releases the cooled air back to the switch cabinet.

☒ The cooling units are controlled with a temperature sensor (7). It detects the air temperature inside the switch cabinet.

2.4.7 Safety concept



WARNING

Danger due to modified safety equipment

Non-functioning or defective safety equipment can cause severe accidents.

- Any changes to the unit, particularly the safety equipment, are prohibited.
- In case of defective safety equipment, shut down the unit and decommission it immediately.

- Cooling units have a pressure switch tested in accordance with EN 12263. It reacts to a pressure increase in the refrigerant circuit by shutting off automatically.
- Fans and compressors are protected from overloading and overheating: e.g. the compressor is protected against overlocking.

Additional protective functions (only cooling units with anti-freeze option):

- If there is a risk of ice formation, switch off the compressor and the fans.
- This shut-off function is not withdrawn until a system restart.

2.4.8 Condensate management

Note

Damaged switch cabinet seals impair the function of the unit.

- Regular inspection of the seals assures protection against heavy condensate accumulation.
- Installation of a door contact switch reduces the accumulation of condensate when the switch cabinet is open.

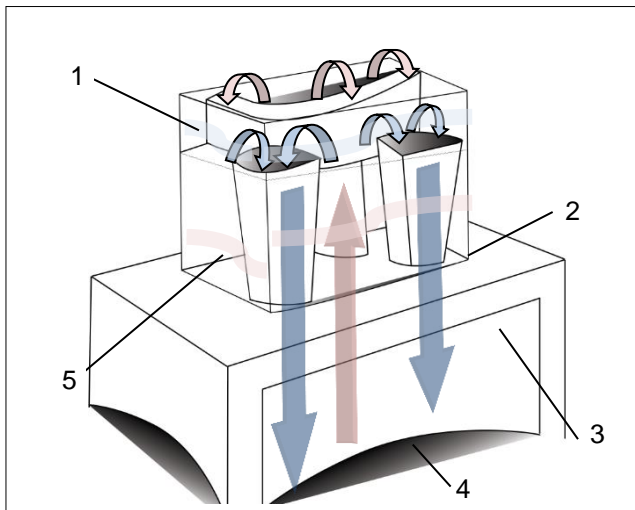

Figure 11 – Cooling circuit arrangement

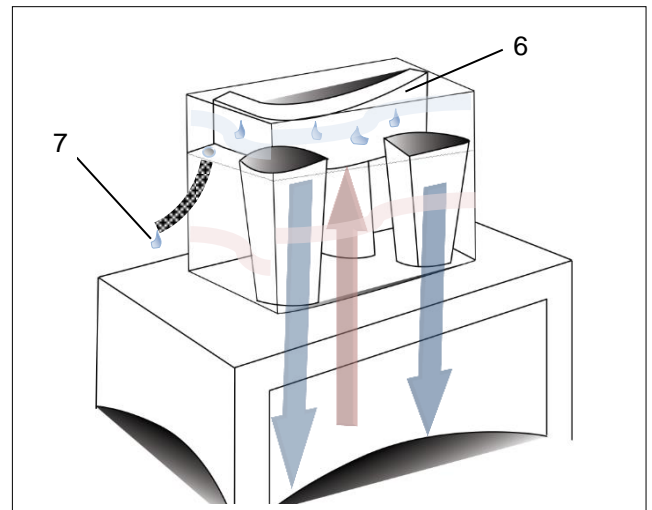

Figure 12 - Condensate drainage

- The main feature of DTT cooling units is the re-positioning of the cooling circuits. The cold circuit (1) is at the top and the hot circuit (5) is at the bottom. No cold bridging (2) can occur in the switch cabinet (3) and, therefore, no condensate accumulates in the switch cabinet interior (4); see the figure Cooling circuits.
- The evaporator unit (6) is situated in the upper section of the DTT cooling unit, so vertical drainage of condensate water is possible. The condensate water does not come into contact with the switch cabinet. For safety reasons, there is a drain port with drain hose on the condensate evaporator (7).
- ☒ Accumulating condensate is collected by a condensate collecting bottle. It is available as an accessory. Always specify the part number when ordering accessories, see [Spare part orders](#).

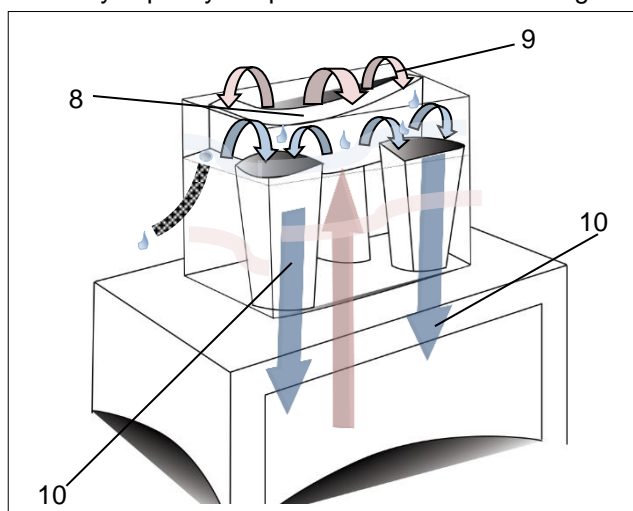

Figure 13 - Evaporator function

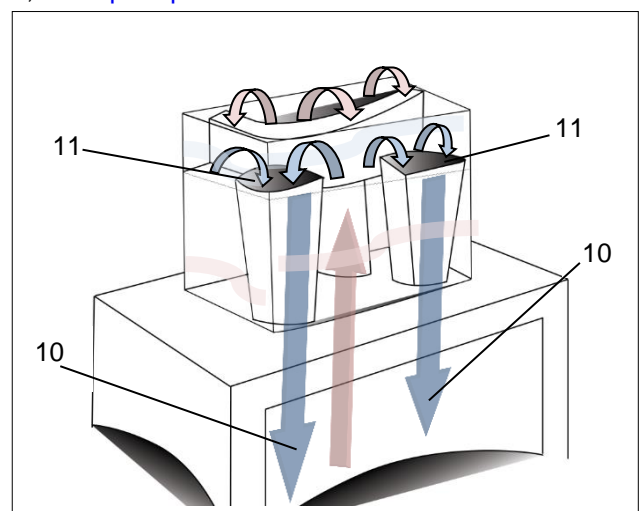

Figure 14 - Air cooling

- Hot air that meets the evaporator in concentrated form causes condensate water. The hot air (9) is distributed over a wide area on the evaporator (8) in the DTT cooling unit. Reduction of the air speed in this manner prevents turbulence, so the air flow (10) towards the switch cabinet is free from condensate.
- DTT cooling units have air outlet nozzles (11) arranged on both sides instead of air hoses. These air outlet nozzles (11) accelerate the cold air (10) and guide it to the switch cabinet floor free from condensate; see the figure Air cooling.

2.5 Type plate



WARNING

Danger due to damage of units

Disregard of type plate specifications can result in severe accidents.

- Always observe the specifications on the type plate when installing and maintaining the units.

- ☒ The type plate is located on the rear side of the cooling unit housing.
- ☒ The figure shows the standard version for EU Member States. The type plate version may differ in other countries.

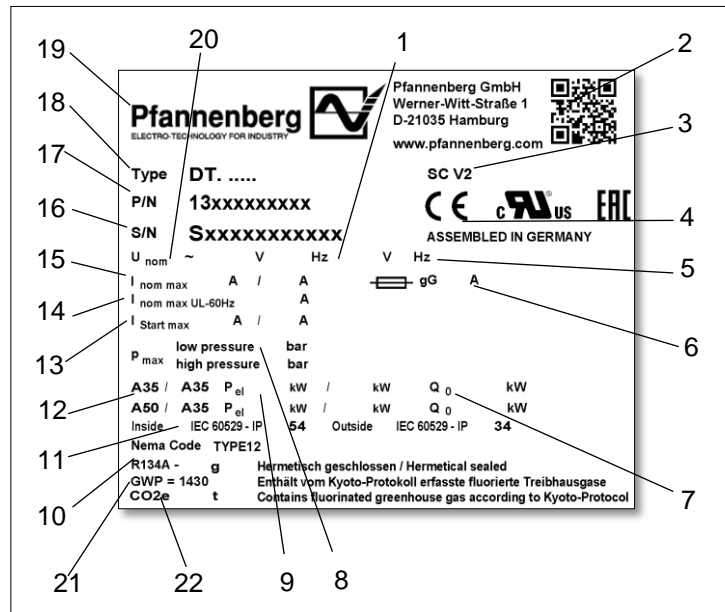

Figure 15 - Type plate for EU Member States

Item	Designation	Item	Designation
1	Frequency	2	QR code
3	Options	4	CE mark
5	Protection type	6	Protection
7	Cooling capacity	8	Coolant pressure
9	Power rating	10	Coolant
11	Protection type	12	Exterior / interior ambient conditions
13	Start-up current	14	Nominal current (UL 60 HZ)
15	Current rating	16	Serial number
17	Article number	18	Unit type
19	Manufacturer logo	20	Rated operating voltage
21	Global Warming Potential	22	CO2 equivalent value

2.6 Technical data

2.6.1 Refrigeration data

Designation		Model DTT 6601		Model DTT 6801	
		50 Hz	60 Hz	50 Hz	60 Hz
Cooling capacity A35 / A35 * / **	Q ₀	3000 W	3200 W	4000 W	4250 W
Cooling capacity A50 / A35 * / **	Q ₀	2000 W	2250 W	3260 W	3495 W
Refrigerant type *		R 134a			
Refrigerant amount *		1250 g			
Thermostat setting (factory set)		+35°C (+95°F)			
Failure indication: Enclosure internal temperature (factory set)		> +50°C (+122°F)			
Ambient air temperature		+15°C (+59°F) bis +55°C (+131°F)			
Enclosure internal temperature		+25°C (+77°F) bis +45°C (+113°F)			
Air volume, external circulation		1970 m ³ /h	2180 m ³ /h	1970 m ³ /h	2180 m ³ /h
Air volume, internal circulation		1420 m ³ /h	1530 m ³ /h	1420 m ³ /h	1530 m ³ /h
Condensation discharge		Condensate evaporator			
Sound pressure level (1m)		≤ 62 dB(A)			

2.6.2 Electrical data

Designation		Model DTT 6601		Model DTT 6801	
		400V/ 50 Hz	460V/ 60 Hz	400V/ 50 Hz	460V/ 60 Hz
Rated operating voltage * / ***		400 / 460 V 3~			
Rated frequency *		50 / 60 Hz			
Operating range		DIN IEC 60038			
Power consumption *	P _{el} A35/A35	1700 W	2100	1601	1989
Rated current*	I _{nom max}	3,16 A	4,5 A	4,6 A	4,5 A
Starting current*	I _{Start max}	8,9 A	9,9 A	17,1 A	19,5 A

2.6.3 Dimensions

Designation		Model DTT 6601		Model DTT 6801	
Height		485 mm			
Width		795 mm			
Depth with cover (standard)		575 mm			
Weight		75 kg		77 kg	
Installation attitude		Vertical			
Unit construction		Standard: Steel/ plastic			

2.6.4 Other unit data

Designation		Model DTT 6601		Model DTT 6801	
Corrosion protection		Standard: Galvanized, electrostatically powder coated (200°C) Option: Stainless steel unit hood			
Protection classification		Under correct operating conditions: IP 54 against the enclosure (EN 60529). IP 34 against the environment (EN 60529).			

* Data on the type plate.

** Use of optional filter mats reduces the cooling capacity.

*** With a change to the rated operating voltage, see [Adapting the](#) upstream fuse /transformer options.

3 Assembly and initial commissioning

3.1 Transport



Danger due to uncontrolled movements

Improper securing of the unit can result in severe accidents.

- Loading must only be carried out by trained, qualified personnel.
- Lash the unit correctly for transport on a truck or trailer.
- Only use lashing straps with an adequate rated strength.
- Use slip-resistant materials for securing, e.g. anti-slip mats.
- When loading by crane, do not walk or stand under the raised units.

NOTE

Danger of material damage during transport and setting down of the units.

- Improper device securing or uncontrolled movements can cause damage.
- Exercise maximum caution during movement and transport of the units.
- Always transport the unit in the position of use.

Transport of the cooling units must always take place with the packaging provided at the factory. It comprises an outer carton, bottom plate and base and top cushions.

Transporting cooling units

Requirements

- Cooling unit are in the packaging provided by the factory.

Required tools and material

- Lashing straps, loading crane, if applicable

Procedure

- Secure correctly for transport with lashing straps. Always transport in the position of use.
- Always raise cooling units by the housing.
- Always raise cooling units slowly and evenly and set down safely.

⇒ *The cooling units was transported and loaded correctly.*

☒ The cooling unit can also be loaded using M8 jack rings or placed on the switch cabinet. For this purpose, screw the M8 jack rings into the cooling unit beforehand; [Mounting M8 jack rings](#).

3.2 Storage

- Do not expose the cooling unit to temperatures above +70 °C during storage.
- Always store the cooling unit in the position of use.
- ☒ The warranty will no longer apply if these instructions are not observed.

3.3 Unpacking

WARNING

Danger of accidents due to the heavy weight of the units

Uncontrolled movements of the units during assembly can cause accidents.

- Use suitable lifting equipment and secure units to prevent accidents.
- Also secure assembled components.

CAUTION

Danger of injury due to sharp edges

- For manufacturing reasons, the metal edges of the unit may have burrs.
- Wear gloves during service and assembly work.

- Perform a visual inspection for transport damage when unpacking the cooling units. Take note of any loose parts, dents, scratches, visible loss of oil etc.
- Inspect the packaging material for any loose functional parts before disposal.
- ☒ Reported any damages to the freight carrier immediately. Observe the "Terms for Cases of Damage".
- ☒ Precise information about defects, including possible photos must be provided for the handling of warranty claims. Always specify the type designation and serial number.
- ☒ The "General Terms for Deliveries and Services" of ZVEI (Zentralverband der Elektrotechnischen Industrie; Central Association of the Electrical Engineering and Electronics Industry, in Germany) according to the latest revision apply.

3.4 Assembly

DANGER

Life-threatening danger due to electric shock

Live units and exposed connection cables can generate an electric shock and cause severe accidents.

- Work on electrical connections must be carried out exclusively by trained, qualified electricians.
- Before assembly, de-energize all supply lines to the separate fuse or a main switch, disconnect the system and secure to prevent re-connection.
- Test to ensure the absence of voltage on the unit.

WARNING

Danger of falling during unit assembly on the switch cabinet roof

There is a danger of falling during assembly work on the switch cabinet roof due to defective, missing or untested personal safety equipment.

- Plan carefully and proceed cautiously when carrying out the assembly work.
- Use a suitable safety ladder that is secured to prevent tipping over.
- Wear personal protective equipment.

CAUTION

Danger of crushing during assembly of the unit

There is a danger of crushing between the switch cabinet and frame of the unit during assembly.

- Keep body parts out of the space between the frame and unit cut-out.
- Work carefully and wear gloves.

3.4.1 General assembly requirements

NOTE

Switch cabinet installation hazard due to assembly chips

When making the cooling unit cut-outs, assembly chips can fall into the switch cabinet.

- When assembling the switch cabinet, protect against contaminants and use protective covers.

The following general requirements must be followed for safe and reliable operation of the cooling units:

- The place where the switch cabinet is mounted must be selected so as to guarantee adequate ventilation of the cooling unit. A minimum clearance of 200 mm between units and from the nearest wall must be observed.
- Installed components in the switch cabinet must not impede air circulation.
- Secure the switch cabinet against tipping.
- Ensure that provided hinges can support the additional weight of the cooling unit.
- Assembly of the cooling unit can take place with and without an external unit cover.
- Protect the installation location from heavy contamination with covers.

3.4.2 DTT cooling unit assembly (installation)

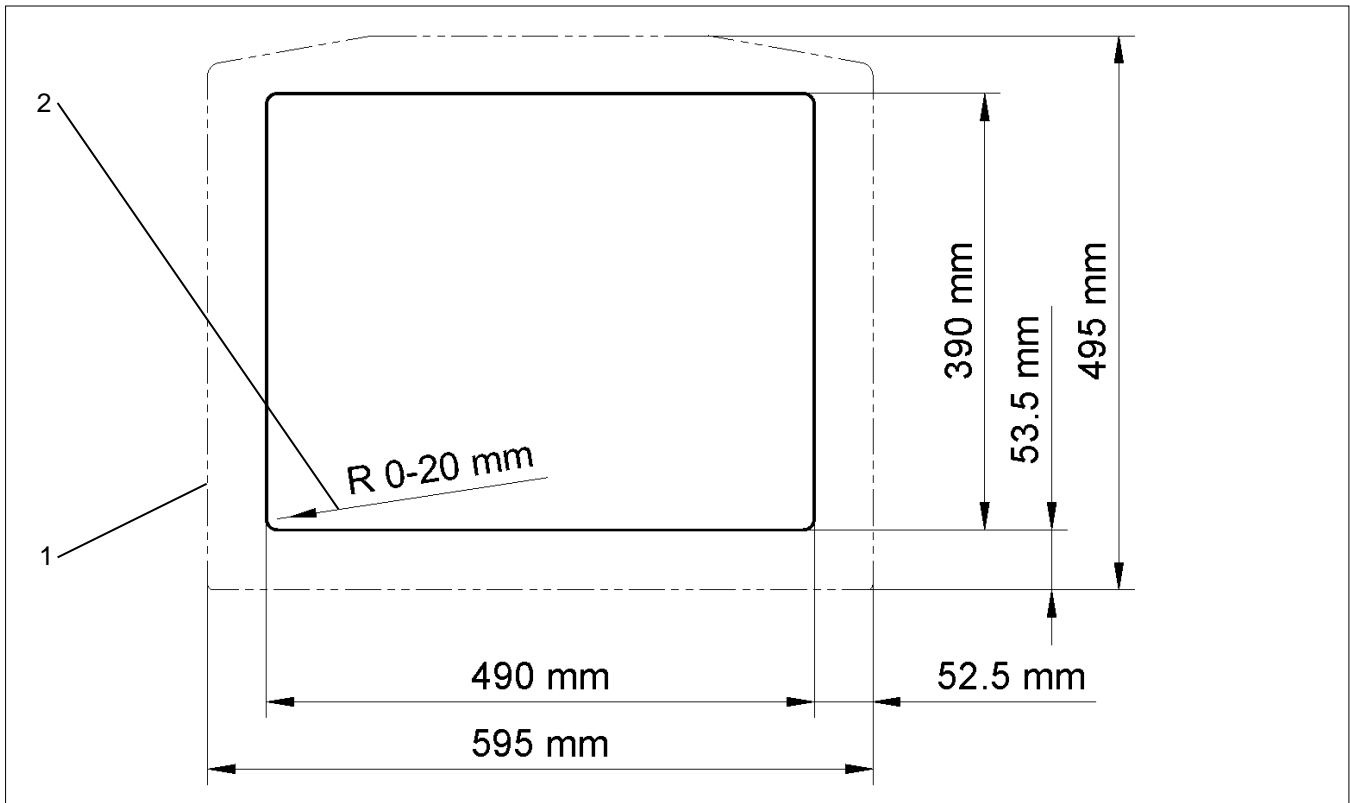

Figure16 – DTT switch cabinet cut-out

Item	Designation	Item	Designation
1	Unit contour	2	Cut-out angle

Make cut-outs for the DTT cooling unit

2

Requirements

- All general requirements are fulfilled, see [General assembly requirements](#)
- The cooling unit is de-energized.

Required tools and material

- Saw
- Use a switch cabinet cutter, if applicable
- Protective covers

Procedure

- Use a protective cover to protect the switch cabinet from chips.
- Provide the switch cabinet with cut-outs and holes. For the prescribed dimensions, refer to the figure [cut-outs for the DTT cooling unit](#).
- Deburr the cut edges.
- Remove chips and assembly waste from the switch cabinet.

⇒ *Cut-outs and holes have been made.*

3.4.3 Mounting M8 jack rings

WARNING

Danger due to uncontrolled movements and high weight of the units

Improper securing of the unit can result in severe accidents.

- Assembly must only be carried out by trained, qualified personnel.
- Do not walk or stand under the raised units.
- Use suitable lifting equipment and secure units to prevent accidents.
- Use belts with a sufficient rated strength to lift the units.
- Secure assembled components immediately.

WARNING

Danger of accidents due to unapproved crane transport

Movement of switch cabinets with integrated cooling units can result in accidents.

- Lifting by M8 jack rings is only permitted for the cooling unit.
- Ensure that jack rings and unit threads are not damaged or deformed.
- Only use jack rings with an adequate thread length and ensure that they are securely seated.

☒ The cooling units have threads for M8 jack ring installation. M8 jack rings can be installed in cooling units for crane transport.

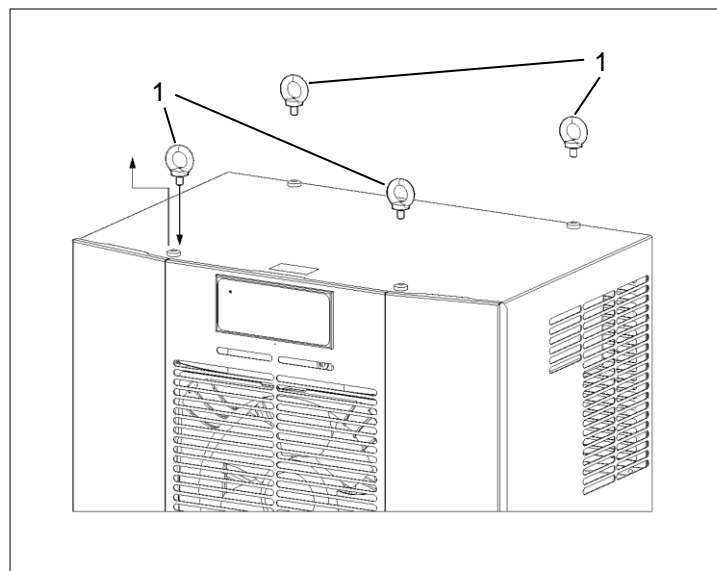

Figure 17 – Installing M8 jack rings

Requirements

- The factory-provided packaging has been removed from the cooling units.
- The minimum screw depth of the M8 jack rings (1) must be observed.
- M8 crane eyes and cooling unit threads must be free from damage (corrosion and deformation).
- The unit cover screws have been removed.

Procedure

- Screw in the two M8 jack rings (1) completely with the appropriate thread depth; see figure [Mounting M8 jack rings](#).
- Check to ensure the proper approved seating of the M8 jack rings in the cooling unit.

⇒ *The M8 jack rings are installed in the cooling unit and the unit can be moved.*

3.4.4 Install flat seal and assemble



WARNING

Danger of accidents due to incorrectly installed seals

Leaky seals can allow moisture to penetrate and cause short-circuits.

- Install the seal so that it provides a tight seal to the switch cabinet.
- Always inspect seals during cleaning and maintenance.

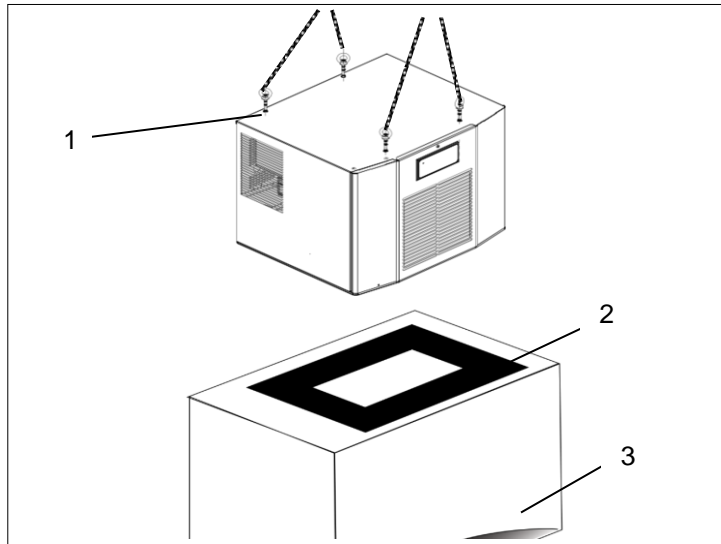

Figure 18 - Flat seal installation and assembly

Flat seal installation and DTT cooling unit assembly

Requirements

- Cut-outs have been made for the cooling unit; see figure [cut-outs for the DTT cooling unit](#).
- The M8 jack rings (1) are screwed into the cooling unit, see [Mounting M8 jack rings](#).
- The cooling unit is de-energized.

Required tools and material

- Flat seal (2), installation tool
- Accessory kit: Threaded bolts, screws, nuts, washers

Procedure

- Adhere the self-adhesive flat seal (2) on the switch cabinet (3).
- ☒ Incorporating a reinforcement on the installation surface provides an optimal seal between the cooling unit and switch cabinet.

⇒ The flat seal is applied and the cooling unit can be assembled.

3.4.5 Switch cabinet assembly

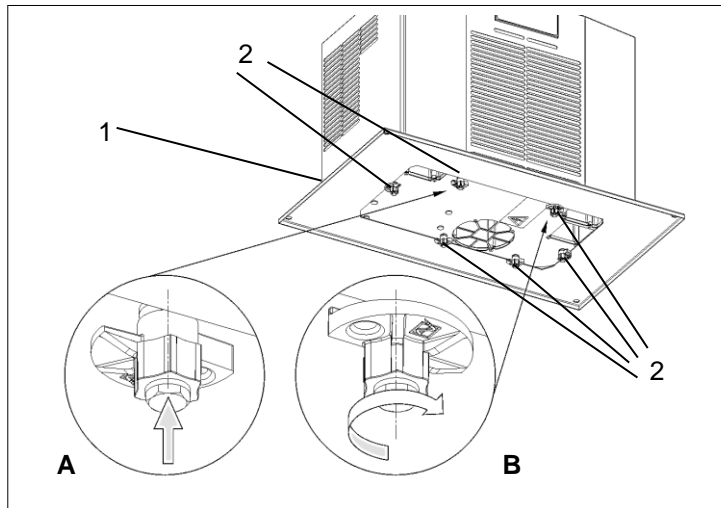

Figure 19 – Cooling unit assembly with casement fasteners

Requirements

- The M8 jack rings are screwed into the cooling unit, see [Mounting M8](#) jack rings.
- The cooling unit is secured correctly with lashing straps.

Required tools and material

- Lashing straps, loading crane, if applicable

Procedure

- Raise the correctly secured cooling unit slowly and evenly; see figure [and DTT cooling unit assembly](#).
- Assemble the cooling unit in a level position.
- Position the cooling unit on the switch cabinet roof and align it with the cut-outs.
- Ensure that the condensate drain (1) is positioned at the lowest point.
- Install the condensate drain hose on a consistent decline and without kinks.
- ☒ The condensate drain hose length must not exceed 3 m.
- ☒ Check regularly during operation to ensure that the condensate water drains correctly.
- Position the cooling unit precisely in the cut-out.
- All six casement fasteners (2) on the inside of the switch cabinet; see the figure Cooling unit assembly - detail A.
- Screw in all six casement fasteners (2) on the inside of the switch cabinet over the rail to mount the cooling unit; see the figure Cooling unit assembly - detail B.

⇒ The cooling unit is attached to the switch cabinet and ready for electrical connection, see .

3.4.6 Assembly with quick-release frame

The quick-release frame offers maximum flexibility for assembly and removal of cooling units.

- It makes replacement of cooling units quick and easy. The assembly cut-outs and fastening points are identical to those for assembly of the cooling unit alone; see figure [cut-outs for the DTT cooling unit](#). This makes retrofitting with the quick-release frame simple and easy; see [ordering spare parts and accessory parts](#).

The quick-release frame has a central locking mechanism that guarantees an absolutely secure connection with the DTT cooling unit.

Unit preparation - front panel removal

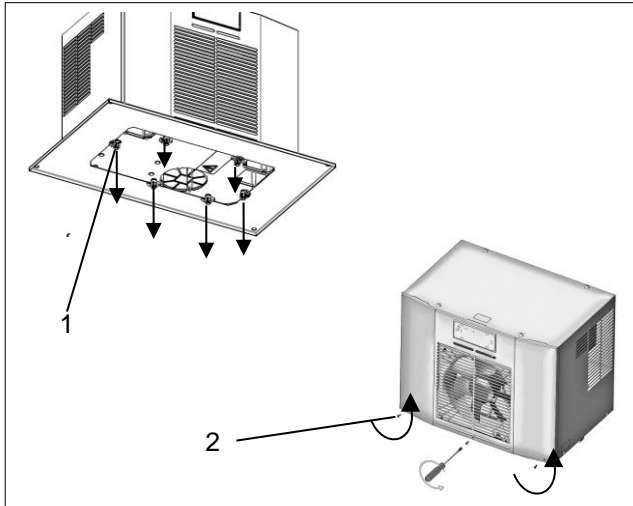

Figure 20 – Loosening the front panel

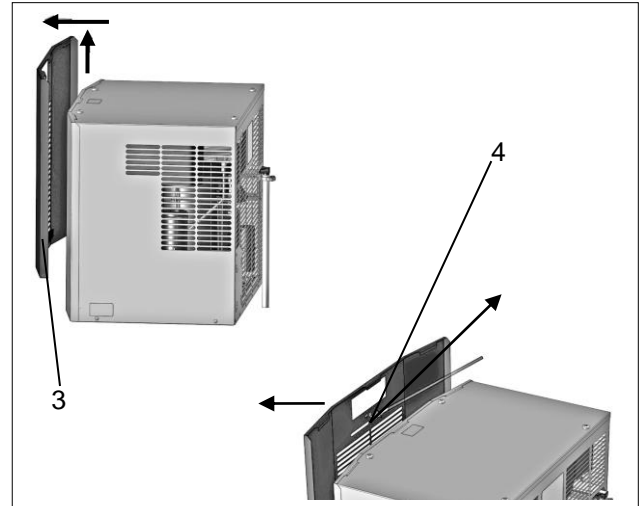

Figure 21 - Front panel removal

Item	Designation	Item	Designation
1	Screws / casement fasteners (6x)	2	Front panel screws (3x)
3	Front panel	4	Ground cable

Requirements

- All general requirements for assembly are fulfilled, see [General assembly requirements](#)
- Cut-outs have been made for the cooling unit; see figure [cut-outs for the DTT cooling unit](#).
- The cooling unit is de-energized.
- The flat seal is applied on the switch cabinet.

Required tools and material

- Assembly tool, screwdriver
- Accessory kit: Bracket (2x), M6x10 mm screws (4x), washers (4x)

Procedure

- Unscrew the six screws (switch cabinet/interior) with the casement fasteners (1).
- ☒ The screws and casement fasteners are required for later assembly of the quick-release frame. Unscrew the three screws (2) on the front panel. Turn the screwdriver counterclockwise to loosen the screws; see the figure Loosening the front panel.
- Carefully slide the front panel (3) upwards.
- Always disconnect the ground cable (4) before removing the front panel.
- Carefully pull the front panel upwards; see the figure Front panel removal.

⇒ The front panel has been removed.

Assembly with quick-release frame
Unit preparation - unit cover removal

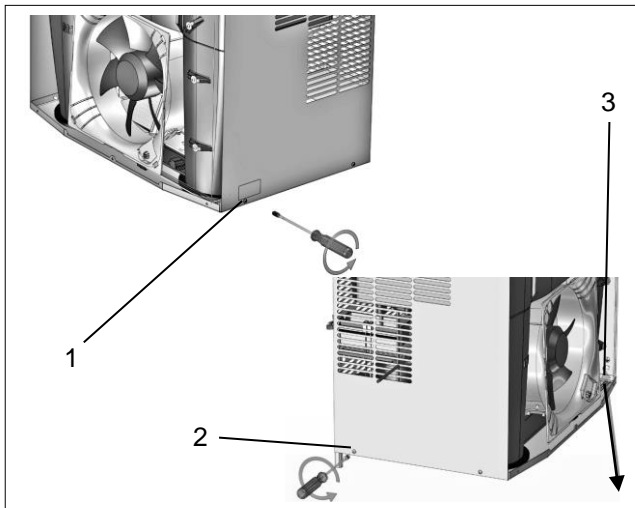

Figure 22 – Loosening the unit cover

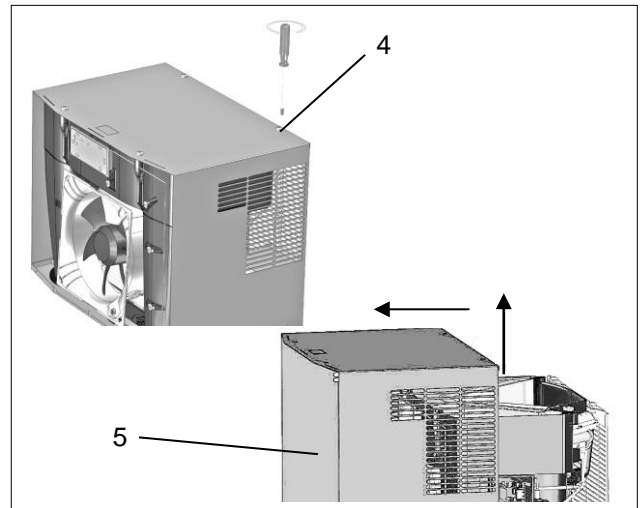

Figure 23 - Unit cover removal

Item	Designation	Item	Designation
1	Right cover screws (2x)	2	Left cover screws (2x)
3	Ground cable	4	Top cover screws (4x)

Procedure

- Unscrew the two screws on the right side of the unit (1) and the two screws on the left side of the unit (2).
- Disconnect the ground cable (3); see the figure Loosening the unit cover.
- Remove the four screws on the top side of the unit (4).
- Carefully pull the unit cover (5) upwards; see the figure Unit cover removal.

⇒ *The cover has been removed from the cooling unit.*

Unit preparation – Bracket assembly

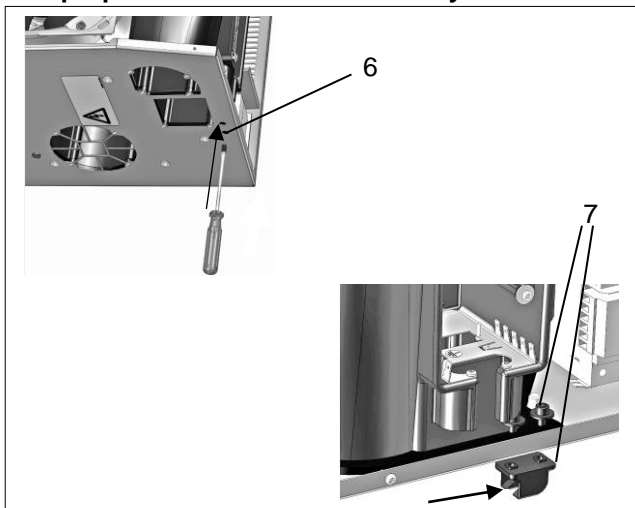

Figure 24 – Bracket assembly

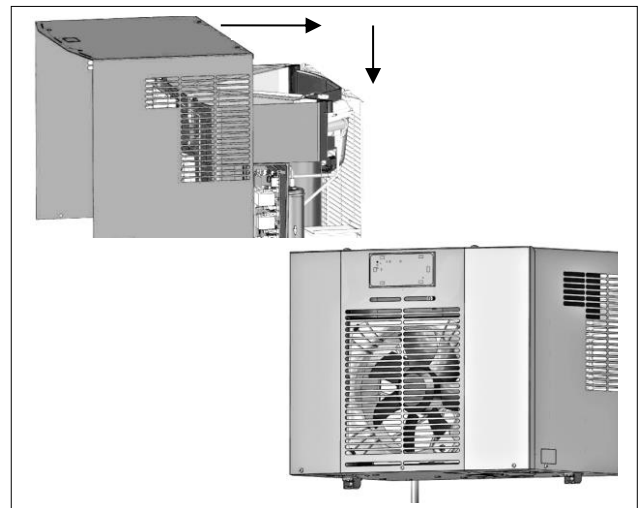

Figure 25 – Cover installation

Procedure

- Make a hole in the insulation of the bracket opening (6) with a screwdriver. Make 2x on the right and 2x on the left.
- Mount the two brackets (7) with the four screws (7) and the four washers (accessory kit). The openings of the brackets face forwards; see the figure Bracket assembly.
- Install the cover and front panel in the reverse order.
- Tighten the screws, connect the ground cables; see the figure – Cover installation.

⇒ *Unit preparation is completed. The cooling unit is ready for installation with the quick-release frame.*

Assembly with quick-release frame

Install the cooling unit on the quick-release frame.

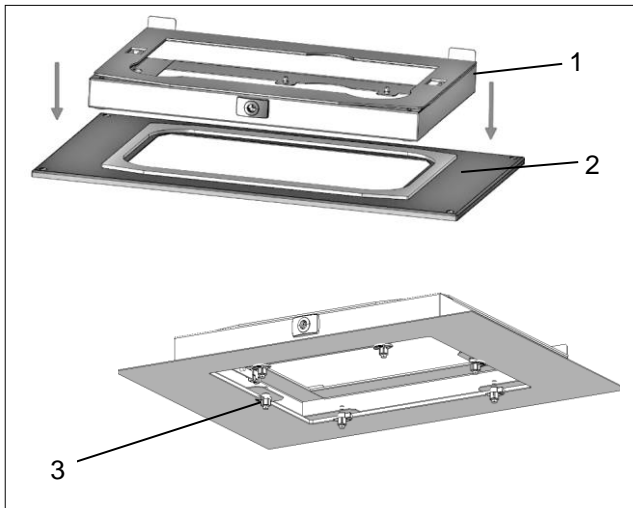

Figure 26 - Quick-release frame/switch cabinet assembly

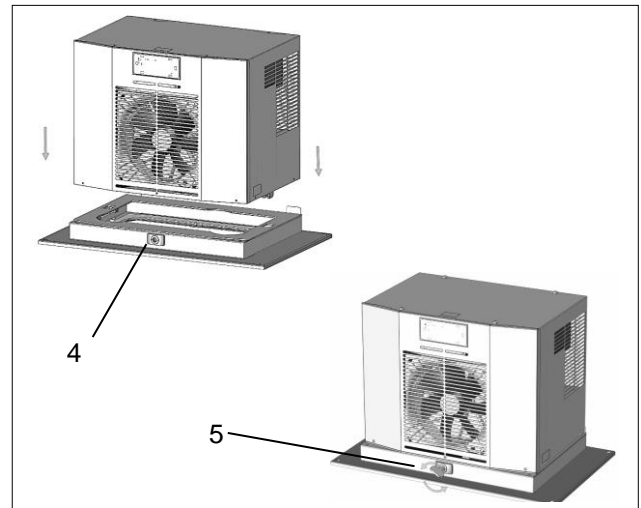

Figure 27 – Quick-release frame/switch cabinet/cooling unit assembly

Procedure

- Position the quick-release frame (1) on the assembly cut-out (2).
- ⊗ The assembly cut-outs and fastening points are identical to those for assembly of the cooling unit alone; see figure [cut-outs for the DTT cooling unit](#).
- Fasten the quick-release frame with screws and casement fasteners (3) on the switch cabinet from the inside; see the figure Quick-release frame/switch cabinet assembly.
- ⊗ When retrofitting, use the screws and casement fasteners which fastened the cooling unit; see the figure [Loosening the front panel](#).
- Insert the cooling unit in the quick-release frame (4).
- Lock the cooling unit in the quick-release frame. Use the wrench (5) provided for this purpose.

⇒ *The DTT cooling unit is attached and ready for electrical connection.*

3.5 Electrical connection
3.5.1 Electrical circuit diagram - Standard controller (SC)



Life-threatening danger due to electric shock

Live units and exposed connection cables can generate an electric shock and cause severe accidents.

- Work on electrical connections must be carried out exclusively by trained, qualified electricians.
- Ensure that the unit is voltage-free before routing all electrical connections.

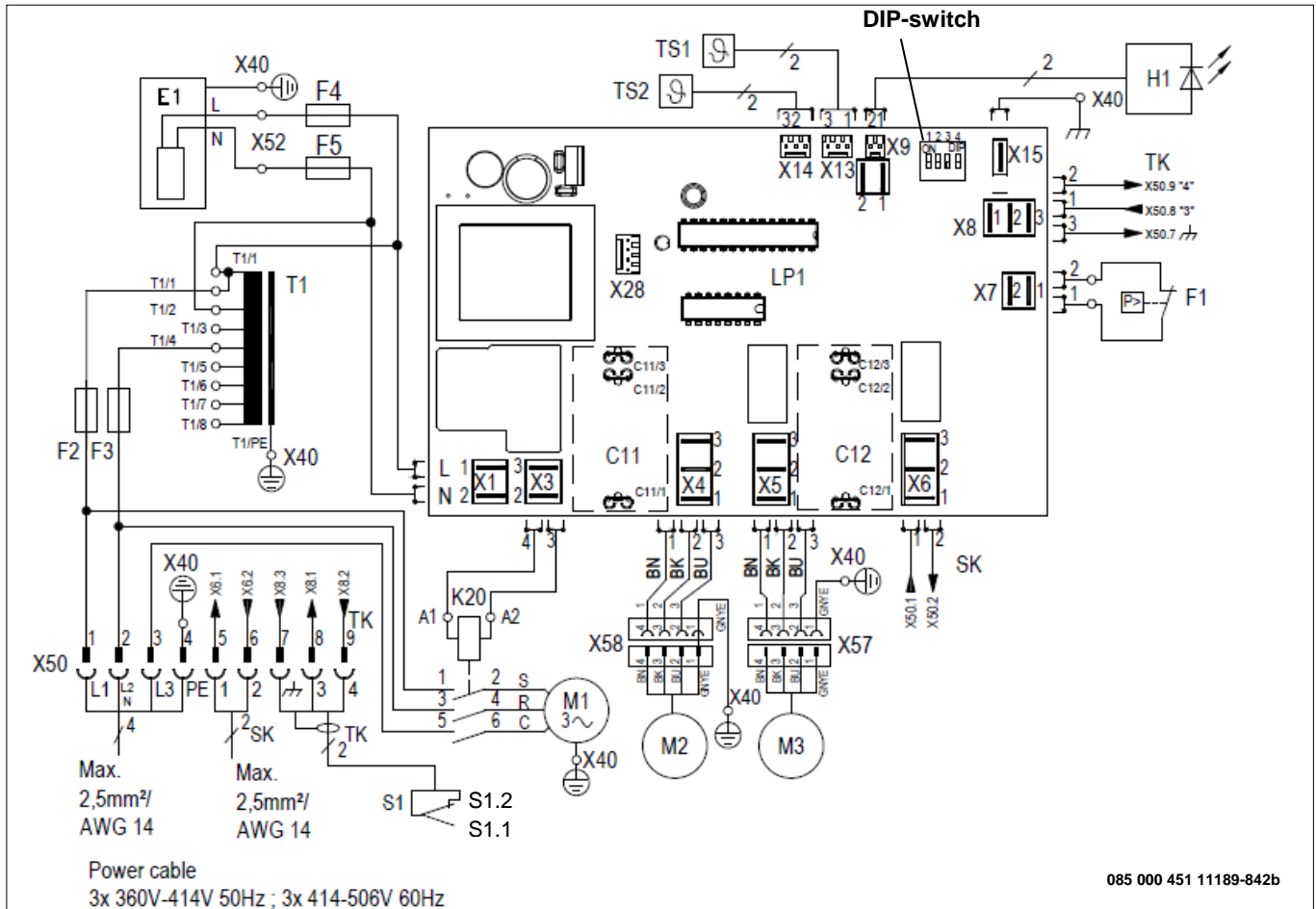

Item	Designation	Item	Designation	Item	Designation
C11	Capacitor condenser fan (external)	C12	Capacitor evaporator fan (internal)	F1	High-pressure pressostat
F2-F5	Fuse	H1	LED / indicator unit	E1	Condensate evaporation
K20	Contacteur compressor	LP1	Controller	M1	Compressor
M2	Condenser fan (external)	M3	Evaporator fan (internal)	S1	Door contact
S1.1	Door open	S1.2	Door close	SK	Fault signal contact (1,2)
TK	Door contact / signal (3,4)	T1	Control circuit transformer	TS1	Temperature sensor (internal)
TS2	Temperature sensor (external)	X40/42	Ground terminal contact	X50	Mains terminal contact + Door contact + Fault indication
X52	Heater condensate contact				

3.5.2 DIP switch

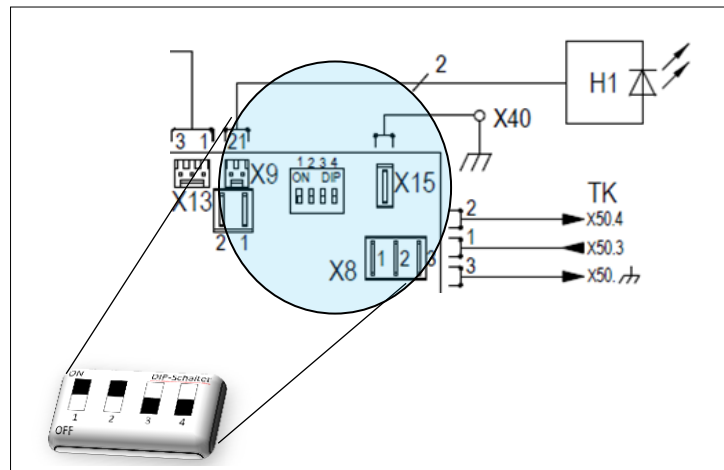

Figure28 - DIP switch

The DIP switch on the control circuit board enables regulation and control of setpoints and limit values for temperatures.

DIP switch (1) position			Temperatures in °C		Temperatures in °F	
			Switch position 4 OFF = °C		Switch position 4 ON = °F	
1	2	3	Setpoint	Max. limit value	Setpoint	Max. limit value
OFF	OFF	OFF	25°C	45°C	77°F	113°F
ON	OFF	OFF	30°C	45°C	86°F	113°F
OFF	ON	OFF	35°C	45°C	95°F	113°F
ON	ON	OFF	35°C	50°C	95°F	122°F
OFF	OFF	ON	40°C	50°C	104°F	122°F
ON	OFF	ON	40°C	55°C	104°F	131°F
OFF	ON	ON	45°C	55°C	113°F	131°F
ON	ON	ON	45°C	60°C	113°F	140°F

☒ Switch off the cooling unit for changes to the DIP switch. Ensure that the unit is voltage-free. The new settings of the DIP switch take effect with next commissioning.

The factory setting is as follows:

- The switch cabinet temperature setpoint is 35°C.
- The maximum switch cabinet temperature is 50°C.

☒ For working on the DIP switch remove the unit cover .Unit cover removal, see [front panel removal](#).

3.5.3 Door contact switch



Danger due to connection of external voltage at the input of the door contact

External voltage can cause severe accidents.

- Connection of external voltage to the input for the door cabinet is prohibited.
- The input/door contact provides low voltage (< 20V, 20mA) for the door contact switch.

Installation of a door contact switch increases safety and prevents increased accumulation of condensate.
 ☒ If a door contact switch has not been connected, the connection contact (S1) must always be bypassed.

Door contact switch installation

Requirements

- The cooling unit is de-energized.

Procedure

- The door contact switch is connected to the S1 connection; see or the electrical circuit diagram in the housing cover.
 - The door contact is supplied with low voltage, <20V, 20 mA, from the cooling unit.
 - Connect the shielding to the terminal for functional earth on one end.
 - A shielded cable with twisted pairs is used to prevent interference.
 - If shielded cables are not used, ensure that there are no sources of interference in the immediate vicinity. Sources of interference include: supply cables and components with increased electromagnetic radiation, including frequency converters, motor drives, etc.
- ⇒ The door contact switch is connected. The motors switch off when the switch cabinet is opened.

3.5.4 Mains supply connection



Potential danger due to incorrect cables

An incorrect cable cross-section will cause the cable to overheat. Scorched insulation can cause fires.

- The cable cross-section (4) matches the output required for the power consumption and is 0.5 – 2.5mm² or AWG 20 to AWG 14.



Electric arcing can cause electric shock and burns.

When disconnecting and connecting the plug connector for mains connection under load or voltage, electric arcing, dangerous voltage and electric shock can occur.

- The plug connector for mains connection must never be plugged in or disconnected under load/voltage.
- Work on plug connectors must only be carried out with adequate lighting.
- Always switch off the circuit breaker and secure against reconnection.

The following general requirements must be assured for safe and reliable operation of the cooling units:

- Upstream installation of a supply-side temperature regulator is prohibited.
- Connect the fuse specified on the type plate as a power contactor; see [type plate](#) and Adapting the [upstream fuse](#).
- Ensure that the type plate specifications for rated values match the present values for mains voltage and mains frequency; see [type plate](#)
- Always connect the cooling unit to the mains by means of a separating device (switch/contactor).
- ☒ The separating device must have a contact opening of 3 mm. The separating device is installed by the customer.

Cooling unit electrical connection

DANGER

Life-threatening danger due to electric shock

Circuit breaker systems that are not connected or attached incorrectly can generate hazardous voltages and electric shock and cause severe accidents.

- Work on electrical connections must be carried out exclusively by trained, qualified electricians.
- Circuit breakers systems must be provided in accordance with DIN EN 60204-1, chapter 8.2.
- Each element of electrical equipment must be connected to the circuit breaker system.
- Never interrupt the circuit breaker system if electrical equipment is attached to covers, doors or cover panels.
- If parts are removed, e.g. for maintenance work, ensure that the circuit breaker system is not interrupted for the remaining parts.

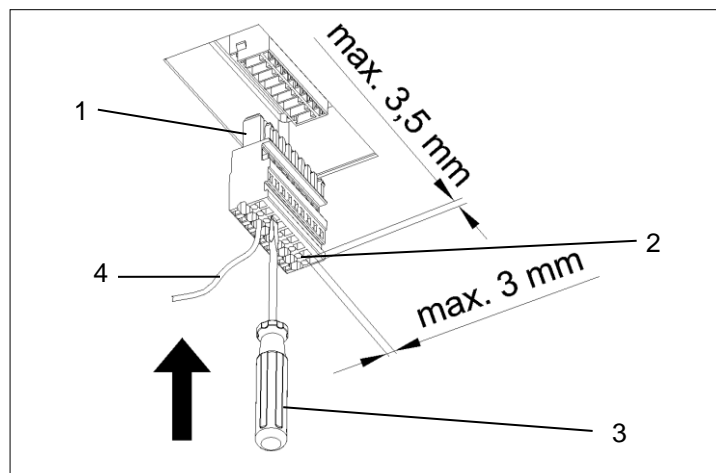

Figure 29 - Cooling unit plug connection

Item	Designation	Item	Designation
1	Connecting plug	2	Cage terminal - max. 3.5 x 3.0 mm
3	Screwdriver (slotted)	4	Cable - Ø 0.5 – 2.5mm ²

☒ Protective conductors in the mains connection cable do not apply as equipotential bonding conductors.

Requirement

- All general requirements for safe and reliable operation are assured; see [Mains supply connection](#) .
- The cooling unit is de-energized.

Procedure

- Connect the cable (4) with the connecting plug (1)/ (accessory kit) as specified in the electrical circuit diagram; see .
- For electrical connection insert the screwdriver (3) into the cage terminal (2) and connect the cables (4) to the cooling unit with the connecting plug (1).
- ☒ Insert the screwdriver firmly into the cage terminal (2). Never twist the screwdriver; otherwise the cage terminal (2) will be damaged.
- Before switching on, ensure that the mains voltage matches the upstream fuse; see .

⇒ *The cooling unit is connected electrically.*

3.5.5 Adapting the upstream fuse /transformer options

- ☒ Only cooling units with the rated operating voltage 400V / 460V can be optionally connected to a different mains voltage.
- Reconnection takes place via the supply of the primary side of the transformer.
- ☒ The upstream fuse must match the changed mains voltage; see Adapting the upstream fuse.

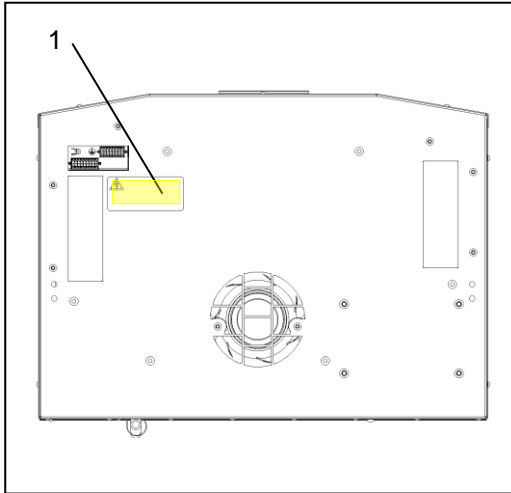

Figure 30 - Transformer options

☒ The specifications for the factory settings of the transformer are provided on the yellow connection diagram (1) on the rear side of the unit.

☒ UL-conformity with the following fuses:
Category "ClassCC", slow-burning.

Voltage Range (V)		Transformer - Option		Pre-fuse (Min. 480 V)
50HZ	60HZ			
360-418	-	380V	T1/1(0) - T1/3 (380)	Max 4A
360-440	-	400V	T1/1(0) - T1/4 (400)	Max 4A
378-440	-	420V	T1/1(0) - T1/5 (420)	Max 4A
-	414-484	440V	T1/1(0) - T1/6 (440)	Max 4A
-	414-506	460V	T1/1(0) - T1/7 (460)	Max 2,5A
-	432-506	480V	T1/1(0) - T1/8 (480)	Max 2,5A

3.5.6 Collective fault signal

- Two connections are provided for connection of the collective fault signal. They are marked with the item designation SK; see .
- The fault signaling contact is potential-free.
- ☒ Ensure that the contact is loaded with a maximum of 230V, 1 A.

4 Operation

4.1 General functions

NOTE

Danger of damage to the cooling unit

Operation without the unit cover prevents the adequate supply of air to the condenser and limits the intended heating function.

- Only operate the cooling unit with the unit cover installed.

The standard controller (SC) has a display unit with a green LED light (1). With the DIP switch (4), various switch cabinet temperature setpoints and upper limit temperatures can be adjusted. If an error occurs, the green LED light (1) blinks.

- If assembly and installation work are completed, switch on the power supply to the cooling unit.
- The cooling unit starts its operation and the LED light (1) of the display unit illuminates green continuously.

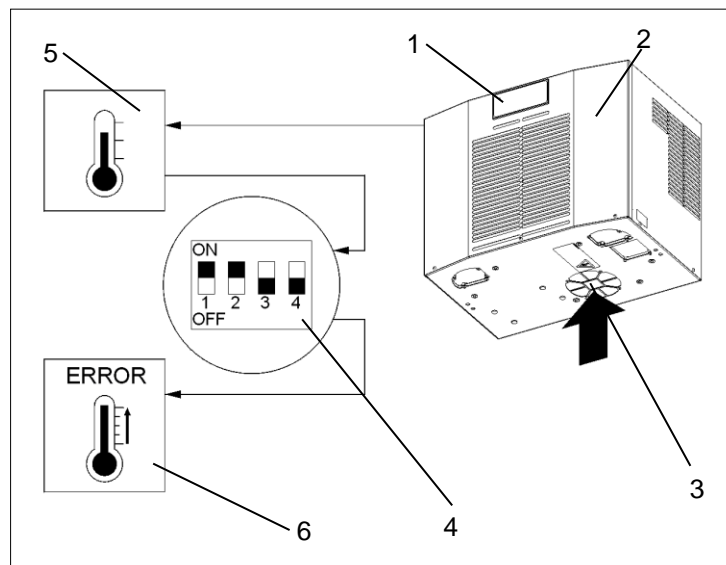

Figure 31 - Electronic control function

- After the supply voltage has been connected and the door is closed, the units run continuously.
 - ⊗ Exception: Energy-saving mode and antifreeze option.
- The cooling unit (2) is equipped with an electronic control unit. A temperature sensor (5) detects the temperature of the air sucked in from the interior of the switch cabinet (3).
- The various switch cabinet temperature setpoints and upper limit temperatures are specified with the DIP switch (4); see [DIP switch](#).
- If the upper or lower limit temperature is exceeded or undercut, a fault indication is triggered (6).
- The green LED light (1) blinks for a fault indication.
- With the standard controller (SC), the readout of system messages or error information is only possible via the USB adapter, ECoolPLANT 2.X configuration software, with USB driver software.
- ⊗ The ECoolPLANT software 2.X is available for download free of charge on the website: <https://www.pfannenberg.com/>.
- ⊗ The corresponding operating manual for the ECoolPLANT software is available [HERE](#) and from My Pfannenberg.
- ⊗ The ambient conditions and switch cabinet interior temperatures must correspond to the prescribed technical data; see [Technical data](#).
- ⊗ The ambient temperature must be less than 55°C; see [Air flow functional principle](#).

4.2 Operation of the cooling unit

Note

Condensate can damage the electronic components in the switch cabinet.

Internal temperatures below the dewpoint or damaged switch cabinet seals cause excessive accumulation of condensate.

- Regular inspection of the seals assures protection against heavy condensate accumulation.
- Ensure that the accumulating condensate can drain freely.

- After connection of the mains voltage, the device switches to startup/test mode or directly to operating mode. The controller equipment determines which mode is activated.
- In operating mode, the cooling units switches to cooling mode as needed. This takes place depending on whether a temperature switching threshold (TSet) is reached or undercut.
- ☒ Cooling mode switches off when the temperature switching threshold (TSet) is undercut. It continues running if the temperature switching threshold (TSet) has not been reached yet.
- ☒ The evaporator fan (internal) fan (external) and compressor switch off when the door is opened.

Operating conditions

- The mains voltage must lie within the specified range; see [Technical data](#).
- ☒ A deviation of $\pm 10\%$ is permissible.
- The rated frequency must be within ± 3 Hz of the value specified.
The ambient temperature must be below 55 °C. For further options, see [Technical data](#).
- ☒ The cooling unit must only be used in such a manner as to ensure that the specified cooling capacity is able to meet actual demands.
- ☒ Only the specified coolant may be used.

NOTE

Spare parts from third-party manufacturers can damage the unit

Internal temperatures below the dewpoint or damaged switch cabinet seals cause excessive accumulation of condensate.

- Only use specially harmonized manufacturer parts for safe and reliable operation.
- ☒ For Pfannenberg spare part numbers, see [ordering spare parts and accessory parts](#).

4.3 Service interface



Life-threatening danger due to electric shock

Live units and exposed connection cables can generate an electric shock and cause severe accidents.

- Work on electrical connections must be carried out exclusively by trained, qualified electricians.
- Ensure that the unit is voltage-free before routing all electrical connections.

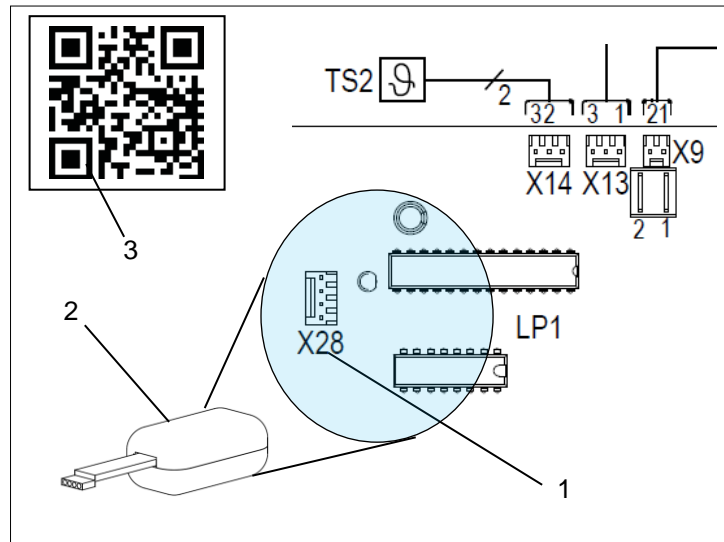

Figure 32 - Service interface

- The service interface (1) can be used to change operating parameters. It is installed inside the DTT cooling unit, so the unit cover must be removed for connection to the USB adapter.
- Unit cover removal, see [front panel removal](#).
- The connection (1) for the USB adapter is provided on the controller circuit board. It is identified as X28 on the electrical circuit diagram.
- ☒ The blinking of the red LED light on the controller circuit board is not a fault indicator or error message. The red LED light indicates that voltage is supplied to the cooling unit.
- To change operating parameters, a USB adapter (2) and the ECoolPLANT 2.X configuration software and USB driver software are required.
- The USB adapter enables connection to a computer that works with the ECoolPLANT 2.X configuration software. The detailed use is described in the corresponding operating manual for the ECoolPLANT 2.X software.
- Remove the USB adapter (2) from the unit after use. The service interface (1) is only provided for temporary data exchange in order to read system notifications, etc. Continuous operation is prohibited.
- ☒ The USB adapter is available as an accessory, see [ordering spare parts and accessory parts](#).
- ☒ The ECoolPLANT software (3) is available for download free of charge on the website: <https://www.pfannenberg.com/> – QR code (3) available.
- ☒ The corresponding operating manual for the ECoolPLANT software is available [HERE](#) and from My Pfannenberg.

4.4 Error messages

The error numbers are not displayed for units with standard controllers: With the ECoolPLANT software it is possible to read the error numbers on the computer.

☒ The blinking of the red LED light on the controller circuit board is **not** a fault indicator or error message. The red LED light indicates that voltage is supplied to the cooling unit.

Error no.	Fault	Unit activity	Possible causes	Corrective measures
Er00	<ul style="list-style-type: none"> • LED: • Compressor: • Evaporator fan (internal): • Condenser fan (external): • Fault signal contact: 	Blinking OFF OFF OFF Closed	<ul style="list-style-type: none"> • Door contact: • The door contact loop has been interrupted. 	<ul style="list-style-type: none"> ▪ Close door. ▪ Connect door contact switch. ▪ Bypass door contact. ▪ Check wiring.
Er01	<ul style="list-style-type: none"> • LED: • Compressor: • Evaporator fan (internal): • Condenser fan (external): • Fault signal contact: 	Blinking OFF ON OFF Open	<ul style="list-style-type: none"> • Pressostat tripped: • Excessively high pressure has built up in the refrigerant circuit. The cooling unit cannot dissipate the heat from the refrigerant circuit. 	<ul style="list-style-type: none"> ▪ Allow the unit to cool down. ▪ Clean the heat exchanger fins (internal/external). ▪ Liquefier- Check fan (external) for function.
Er04	<ul style="list-style-type: none"> • LED: • Compressor: • Evaporator fan (internal): • Condenser fan (external): • Fault signal contact: 	Blinking OFF OFF OFF Open	<ul style="list-style-type: none"> • Phase sequence / phase loss: • Failure of at least one phase or phase sequence is incorrect (only with alternating current units with rotating piston compressors). 	<ul style="list-style-type: none"> ▪ Check the field of rotation - (clockwise rotation is required). ▪ All phases must carry rated voltage.
Er05	<ul style="list-style-type: none"> • LED: • Compressor: • Evaporator fan (internal): • Condenser fan (external): • Fault signal contact: 	Blinking ON ON ON Open	<ul style="list-style-type: none"> • Sensor 1 (TS1) defect. 	<ul style="list-style-type: none"> ▪ Replace Sensor 1 (permanently soldered on the controller circuit board) or the overall controller circuit diagram according to the unit type.

Error messages

Error no.	Fault	Unit activity	Possible causes	Corrective measures
Er07	<ul style="list-style-type: none"> • LED: • Compressor: • Evaporator fan (internal): • Condenser fan (external): • Fault signal contact: 	<p>Blinking ON</p> <p>ON</p> <p>ON</p> <p>Open</p>	<ul style="list-style-type: none"> • Sensor 1 Maximum: The maximum value of the switch cabinet temperature "Lit" (display) has been reached or exceeded. The cooling unit cannot sufficiently cool the air in the switch cabinet. 	<ul style="list-style-type: none"> ▪ Check the settings of the cooling unit. ▪ Clean the heat exchanger fins (internal/external). ▪ Evaporator- Check fan (internal) for function. ▪ Check the refrigeration circuit for escaping refrigerant or leaks. ▪ If necessary, install a cooling unit with a higher cooling capacity.
Er08	<ul style="list-style-type: none"> • LED: • Compressor: • Evaporator fan (internal): • Condenser fan (external): • Fault signal contact: 	<p>Blinking ON</p> <p>ON</p> <p>ON</p> <p>Open</p>	<ul style="list-style-type: none"> • Sensor 2 (TS2) defect. 	<ul style="list-style-type: none"> ▪ Replace Sensor 2 according to the unit type. ▪ Sensor 2 is plugged into the circuit board, not permanently soldered in place.
Er15	<ul style="list-style-type: none"> • LED: • Compressor: • Evaporator fan (internal): • Condenser fan (external): • Fault signal contact: 	<p>Blinking OFF</p> <p>OFF</p> <p>OFF</p> <p>Open</p>	<ul style="list-style-type: none"> • Antifreeze (optional): Antifreeze sensor $\leq 1^{\circ}\text{C}$. Safety shut-off, because there is a risk of icing of the compressor. 	<ul style="list-style-type: none"> ▪ Restart after accumulating condensate water has evaporated. ▪ A restart is only possible with disconnection and re-connection of the mains voltage. ▪ For safety reasons, no other means of resetting is provided. ▪ Clean the heat exchanger fins (internal/external). Inspect the switch cabinet for leaks. ▪ Select higher switch cabinet- Select temperature setpoint. ▪ Evaporator function- Check fan (internal).

5 Service and Maintenance

5.1 General cleaning



DANGER

Life-threatening danger due to electric shock

Live units and exposed connection cables can generate an electric shock and cause severe accidents.

- Work on electrical connections must be carried out exclusively by trained, qualified electricians.
- Before working on the unit, de-energize all supply lines to the separate fuse or a main switch, disconnect the system and secure to prevent re-connection.
- Test to ensure the absence of voltage on the unit.



WARNING

Danger of accidents due to component damage during cleaning

Cleaning of cooling units with water jet, steam jet, high-pressure washer or sharp objects can damage the electrical and electronic assemblies. Malfunctions can cause accidents.

- Do not clean with a water jet, pressure washer or flammable cleaning agents.
- Protect electrical components from the penetration of moisture.
- Do not use pointed or sharp-edged objects to clean the fins. They must not be pinched or damaged.



CAUTION

Danger of crushing during removal of the unit cover

Hands and other body parts can be crushed during removal and re-installation of the unit cover.

- Keep body parts out of the space between the frame, springs and unit cut-out.
- Work carefully and wear gloves.

The frequency of cleaning intervals depends on the operating conditions in the individual case. The following cleaning work must take place regularly for safe and reliable operation of the cooling units:

- Remove dust or environmental residue from the heat exchangers.
- Check the condensate drain regularly.

5.2 Cleaning the cooling unit - Unit cover removal

Requirement

- The cooling unit is de-energized.

Procedure

- Loosen and remove the front panel; see [Loosening the front panel](#).
- ☒ Always disconnect the ground cable before removing the front panel.
- Loosen and remove the unit cover; see [unit cover removal](#).
- ☒ Always disconnect the ground cable before removing the unit cover.

⇒ *The unit cover is removed.*

5.3 Cooling unit and filter mat cleaning tasks

NOTE

Danger of damage to the filter mat due to improper cleaning

- Do not wring out filter mats.
- Avoid water jets with high pressure.
- Immediately replace filter mats that are contaminated with oil or grease.

Requirements

- The cooling unit is de-energized.
- The unit cover is removed.

☒ Time intervals for the cleaning or replacement of filter mats depend heavily on the ambient air contamination.

Required tools and material

- Brush
- Water below 40 °C
- Fine washing detergent
- Vacuum or compressed air cleaner

Procedure

- Clean the heat exchangers using a soft brush or compressed air.
- If the cooling units have a pre-filter the filter mat must be cleaned at regular intervals.
- Wash the filter mat with water with a temperature of up to 40 °C and commercially available fine washing detergent.
- If the dirt is dry, vacuum, blow or knock the dirt off of the filter mat.
- Ensure that correct and safe operation is assured after cleaning.

⇒ *The cooling unit is clean.*

5.4 Maintenance



DANGER

Life-threatening danger due to electric shock

Live units and exposed connection cables can generate an electric shock and cause severe accidents.

- Opening, troubleshooting and replacement of components on the unit must only be carried out by qualified personnel.
- Always ensure that the unit is de-energized before working on the unit.



WARNING

Danger due to improper maintenance work

Damage of components and faulty replacement of components can cause accidents.

- Always switch off the disconnecter/contactator before beginning with maintenance work.
- Ensure that the fans are in idle position and no longer rotate.
- After replacement of defective parts or components, inspect the unit for correct and safe operation.
- After all maintenance or replacement of spare parts, check to ensure the full capability of the condensate drain.



WARNING

Spare parts from third-party manufacturers can damage the unit and cause accidents.

- Only original parts are subject to the manufacturer's quality control.
- Only use specially harmonized manufacturer parts for safe and reliable operation.

NOTE

Danger of unit damage due to incorrectly performed maintenance

Disregard of the recommended maintenance work reduces the cooling capacity of the cooling unit and can result in reduced machine availability.

- Maintenance work must be carried out regularly, as specified in the maintenance checklist.
- Warranty claims are only valid for units that have been maintained according to specifications.

The refrigerant circuit is a maintenance-free, hermetically sealed system. The following preparations are made at the factory:

- Necessary refrigerant quantities are filled.
- All cooling units are tested in the factory in accordance with: DGUV-R 100-500, 2.35 (operation of refrigeration plants, heat pumps and cooling equipment).
- A functional test run was carried out.

Pfannenberg recommendation to the operator for maintenance work:

- Carry out maintenance work regularly, every 12 months, according to the maintenance checklist; see the [template](#).
- Shorter maintenance intervals are required for cooling units that cool in oil- and dust-laden ambient air. A reduced guideline value of two to six months between maintenance intervals applies.
- ☒ The functions of Pfannenberg filters are optimally matched to the cooling units. Therefore, use of Pfannenberg filters has a positive effect on the scope of maintenance work.

5.5 Maintenance checklist template

Cooling unit maintenance checklist				
<p>Maintenance interval: Conduct maintenance every twelve months. Conduct maintenance every two to six months in oil- and dust-laden environmental air.</p> <p>Type: Serial number: Date of maintenance: Technician carrying out the work (name):</p>				
	Unit range designation/ Required maintenance tasks	Visual inspection	To Do	Result
1	System before maintenance			
1.1	General visual inspection of the system			
1.2	Inspection for corrosion damage			
2	Cooling circuit			
2.1	Inspect refrigerant-carrying parts for traces of oil			
2.2	Inspect refrigerant-carrying parts for tightness			
2.3	Inspect electrical connections for damage			
2.4	Inspect evaporator for ice formation			
3	Condenser / heat exchanger			
3.1	Inspect pipe package for deposits			
3.2	Inspection for general corrosion damage			
3.3	Inspect, clean, align fins*			
4	Evaporator / heat exchanger			
4.1	Inspect pipe package for deposits			
4.2	Inspection for general corrosion damage			
4.3	Inspect, clean, align fins*			
5	Condenser fan (external)			
5.1	Inspect mount for loose parts			
5.2	Inspect the electrical connection for damage			
5.3	Check motor bearings for noises			
5.4	Check the drive for signs of overheating			
5.5	Clean fans*			
6	Evaporator fan (internal)			
6.1	Inspect mount for loose parts			
6.2	Inspect the electrical connection for damage			
6.3	Check motor bearings for noises			
6.4	Check the drive for signs of overheating			
6.5	Clean fans*			
7	Pre-filter			
7.1	Replace filter mat*			
7.2	Clean filter mat*			

* Maintenance intervals are more frequent, depending on the degree of contamination.

5.6 Decommissioning

WARNING

Danger of injury due to materials and substances

Improper work on the unit or opening of the refrigerant circuit can result in harm to the health.

- Always ensure that the unit is de-energized before working on the unit.
- The unit must only be disposed of by qualified personnel and in accordance with applicable environmental regulations.

If the cooling unit is no longer needed for a longer period, it must be disconnected from the voltage supply.

☒ Ensure that improper start-up by third parties is not possible.

Final decommissioning

CAUTION

Danger of crushing during the decommissioning of units

Hands and other body parts can be crushed during removal of units.

- Keep body parts out of the space between the frame, springs and unit cut-out.

If cooling units are conclusively decommissioned or disposed of, the following must be observed:

- Applicable statutory regulations of the user country and environmental protection regulations must be observed.
- Refrigerant must be professionally extracted from the refrigerant system. Avoid refrigerant emissions.
- The cooling unit must only be disposed of by authorized, qualified personnel.

☒ Waste equipment must also be disposed of correctly by Pfannenberg. Freight charges for delivery to one of our manufacturing facilities must be pre-paid.

6 Troubleshooting

Fault	Possible causes	Corrective measures
Unit does not cool, Evaporator fan (internal) running	<ul style="list-style-type: none"> Temperature setting too high. 	<ul style="list-style-type: none"> Check the temperature setting.
Unit does not cool sufficiently	<ul style="list-style-type: none"> Operating limits exceeded. 	<ul style="list-style-type: none"> Check the ambient temperature and internal load.
	<ul style="list-style-type: none"> Too little coolant. 	<ul style="list-style-type: none"> Call in authorized qualified personnel to check the unit for leakage.
	<ul style="list-style-type: none"> Heat exchanger dirty. 	<ul style="list-style-type: none"> Clean the heat exchanger.
	<ul style="list-style-type: none"> Evaporator fan (internal) defect. Condenser fan (external) defect. 	<ul style="list-style-type: none"> Call in authorized, qualified personnel; replace fan.
	<ul style="list-style-type: none"> Disturbance in the air circulation inside the cabinet. 	<ul style="list-style-type: none"> Check the installation and the path of air circulating in the switchgear cabinet. Check the supply and outlet flow of air of the cooling unit to the inlet and outlet opening of the switch cabinet. Check DIP switch and cable connections.
Unit cools only periodically	<ul style="list-style-type: none"> Temperature set incorrectly or defective. 	<ul style="list-style-type: none"> Set the DIP switch to a higher temperature.
Condensate accumulates in the switch cabinet	<ul style="list-style-type: none"> Exhaust temperature is too high. 	<ul style="list-style-type: none"> Close the cabinet door.
	<ul style="list-style-type: none"> Switch cabinet is not sufficiently sealed. 	<ul style="list-style-type: none"> Correct leaky points or seals on the switch cabinet. Check the temperature setting.
Condensate does not drain	<ul style="list-style-type: none"> Condensate drain is plugged up. 	<ul style="list-style-type: none"> Clean the condensate drain. Check whether the condensate drain hose is free from kinks and is installed with a downward slope.
Condensate drains from the unit	<ul style="list-style-type: none"> Condensate evaporator defector is too much condensate accumulates. 	<ul style="list-style-type: none"> Replace fuses for the condensate evaporator.
	<ul style="list-style-type: none"> Switch cabinet is not sufficiently sealed. 	<ul style="list-style-type: none"> Correct leaky points or seals on the switch cabinet.

⊗ The blinking of the red LED light on the controller circuit board is not a fault indicator or error message. The red LED light indicates that voltage is supplied to the cooling unit.

7 Spare part orders / accessory orders

No.	Designation	No.	Designation
18811100078	Evaporator fan (internal)	18811000049	Condenser fan (external)
18810200140	Unit cover	18810200143	Stainless steel cover
18810000058	Control panel (MC)	18810000001	Display unit (SC)
18314000100	Condensate collecting bottle	18310000004	USB adapter
18315000005	DTT 6101/6201 PAD frame	18315000000	DTT 6301/6401 PAD frame
18315000001	DTT 6601/6801 PAD frame	18315000001	PAD air channel system*
18300000144	Quick-release frame/ DTT cooling unit 6101/6201	18300000145	Quick-release frame/ DTT cooling unit 6301/6401
18300000146	Quick-release frame/ DTT cooling unit 6601/6801		

* The PAD two-channel system necessitates use of two PAD air channel systems.

- ☒ Always specify the Pfannenberg part numbers when ordering spare parts and accessory parts.
- ☒ The Pfannenberg part numbers for the controller are provided on the transformer of the controller.

8 Terms of warranty

- The warranty does not apply or is voided in the following cases:
 - Improper use of the unit.
 - Failure to observe operating conditions or disregard of the operating manual.
 - If the unit is operated in areas with a corrosive atmosphere or one containing acids.
 - Maintenance not carried out regularly on the cooling units.
 - Damage due to disregard of maintenance recommendations.
 - Damage to cooling units due to soiled or clogged filters.
 - Damage occurring due to unauthorized opening of the refrigerant circuit.
 - Modifications that are carried out on the unit or a change to the serial number.
 - In the event of damage during transport or other accidents.
 - Replacement of parts by unauthorized personnel.

☒ Only original Pfannenberg GmbH parts are permitted for use. Violations void the warranty.

For recognition of warranty claims and return of the unit, observe the following:

- Provide an exact description of the defect and the SRO (RMA) numbers specified by Pfannenberg with the cooling unit.
- Include a reference document (delivery note or invoice copy).
- Forward the cooling unit to us, complete with all accessories, in the original box or in comparable packaging with freight and transport insurance pre-paid.
- ☒ Observe transport instructions; see [Transport](#).

Liability disclaimer:

All information contained was thoroughly checked in March 2017.
However, we make no guarantee as to the completeness and correctness of the specifications.

Legal notice:

Pfannenberg GmbH
Werner-Witt-Strasse 1
21035 Hamburg
Tel. +49 40 734 12-0
www.pfannenberg.com

© Pfannenberg 2017