



Incremental rotary encoder

MNI40N

- Clear function verification via two-color LEDs (red/green)
- Simple installation and adjustment using assistance functions reduce costs
- Self-diagnostics including the magnetic wheel provide quality assurance
- Internal intelligence provides easy setup and reliable operation
- The elastomer coating of the magnetic wheel provides resistance to dirt as well as thermal and mechanical shock
- Long service life at high speeds and temperatures

Magnetic, Non Contact



Function

The magnetic incremental encoder MNI40 combines an exceptionally robust measurement system with intelligent diagnosis and alignment functions in the smallest space. Its highly compact encapsulated housing gives the sensor its high resistance to harsh environmental conditions. The installation-friendly design and simple guided adjustment of the sensor using two-color status LED reduces the installation time considerably.

Dimensions

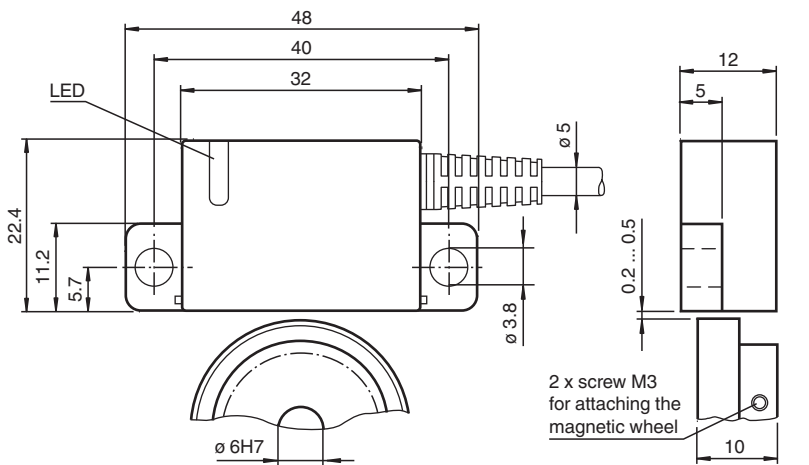

Poles	Ø d [mm]	Ø D [mm]	X [mm]
50	6 10 12 15	31.7	21.9
64	6 19.05 10 20 12 15	40.6	26.35
72	6 20 10 24 12 25 15 30	45.7	28.9
100	35	63.7	37.9

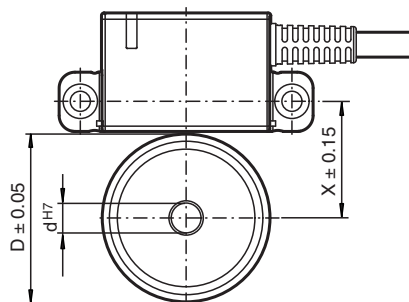

Release date: 2020-05-15 Date of issue: 2020-05-15 Filename: t42651_eng.pdf

Refer to "General Notes Relating to Pepperl+Fuchs Product Information".

Pepperl+Fuchs Group
www.pepperl-fuchs.com

USA: +1 330 486 0001
fa-info@us.pepperl-fuchs.com

Germany: +49 621 776 1111
fa-info@de.pepperl-fuchs.com

Singapore: +65 6779 9091
fa-info@sg.pepperl-fuchs.com

PEPPERL+FUCHS

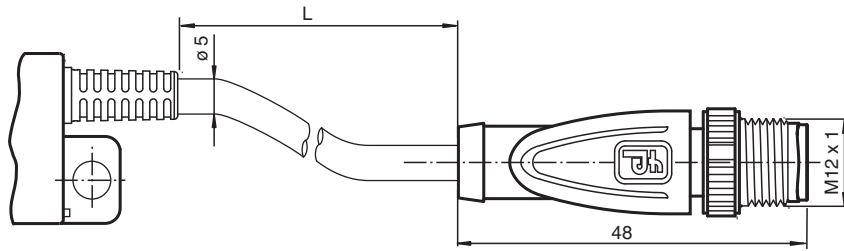

Technical Data

General specifications	
Detection type	magnetic sampling
Pulse count	max. 7200
UL File Number	E223176 "For use in NFPA 79 Applications only" , if UL marking is marked on the product.
Functional safety related parameters	
MTTF _d	942 a
Mission Time (T _M)	20 a
Diagnostic Coverage (DC)	0 %
Indicators/operating means	
LED red/green	Operating display / Alignment aid
Electrical specifications	
Operating voltage	U _B 10 ... 30 V DC 5 V DC for RS-422
No-load supply current	I ₀ max. 55 mA
Output	
Output type	push-pull, incremental or RS-422, incremental
Voltage drop	U _d < 2.5 V
Load current	max. per channel 30 mA , short-circuit protected (max. per channel 20 mA, conditionally short-circuit proof)
Output frequency	max. 1 MHz
Connection	
Cable	Ø4,7 mm, 4 x 2 x 0,128 mm ² connection with plug M12, 8-pin, L = 0.3 m
Standard conformity	
Degree of protection	DIN EN 60529, IP67 , IP68 , IP69K
Climatic testing	DIN EN 60068-2-30
Emitted interference	EN 61000-6-4:2007/A1:2011
Noise immunity	EN 61000-6-2:2005
Shock resistance	DIN EN 60068-2-27, 200 g, 6 ms
Vibration resistance	DIN EN 60068-2-6, 40 g, 10 ... 2000 Hz
Approvals and certificates	
UL approval	cULus Listed, General Purpose, Class 2 Power Source, Type 1 enclosure , if UL marking is marked on the product. adapters providing field wiring on request
Maximum permissible ambient temperature	max. 80 °C (max. 176 °F)
Ambient conditions	
Operating temperature	-40 ... 100 °C (-40 ... 212 °F)
Storage temperature	-40 ... 100 °C (-40 ... 212 °F)
Mechanical specifications	

Release date: 2020-05-15 Date of issue: 2020-05-15 Filename: t42651_eng.pdf

Refer to "General Notes Relating to Pepperl+Fuchs Product Information".

Technical Data

Material	
Housing	PA
Cable	PUR
Magnetic wheel	steel 1.4021 (AISI 420) ferrite filled cured rubber
Mass	approx. 190 g
Rotational speed	max. 30000 min ⁻¹

Connection

Signal	Cable, 8-core	Connection cable with M12 plug, 8-pin
GND	White	1
+U _b	Brown	2
A	Green	3
B	Grey	5
\bar{A}	Yellow	4
\bar{B}	Pink	6
0	Blue	7
$\bar{0}$	Red	8
Screen	-	-

Operation

Signal outputs

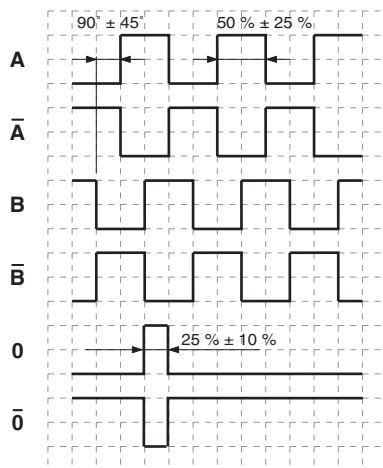

ccw - with top-view

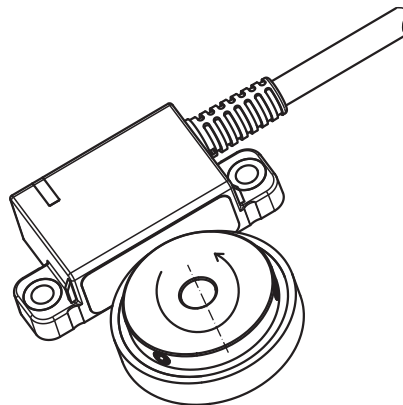

Indication

LED-Indicators

LED status	Description
Green On	Sensor self test and magnetic wheel verification successfully completed.
Green Flashing	Sensor waiting to complete single magnetic revolution for code wheel verification process.
Red Flashing	Warning Alignment or wheel velocity detected as out of specified limits. Possible cause: improper alignment (large sensor-wheel gap, magnetic wheel misalignment, ...)
Red On	Error Possible reason: <ul style="list-style-type: none"> • Supply voltage drop • Magnetic wheel not detectable (e. g. too large gap) • Broken magnetic wheel

Release date: 2020-05-15 Date of issue: 2020-05-15 Filename: t42651_eng.pdf

