

MANUAL

# Strain Gauge Converter KFD2-WAC2-(Ex)1.D



With regard to the supply of products, the current issue of the following document is applicable: The General Terms of Delivery for Products and Services of the Electrical Industry, published by the Central Association of the Electrical Industry (Zentralverband Elektrotechnik und Elektroindustrie (ZVEI) e.V.) in its most recent version as well as the supplementary clause: "Expanded reservation of proprietorship"

<b>1</b>	<b>Symbols used in this document</b>	<b>3</b>
<b>2</b>	<b>Overview</b>	<b>3</b>
<b>3</b>	<b>Safety instructions</b>	<b>4</b>
<b>4</b>	<b>Explosion protection</b>	<b>5</b>
<b>5</b>	<b>Mounting and connection</b>	<b>6</b>
5.1	Mounting	6
5.2	Connection	7
5.3	Front panel	9
<b>6</b>	<b>Display mode and error messages</b>	<b>10</b>
<b>7</b>	<b>Editing device data</b>	<b>11</b>
7.1	Parameterisation mode of the control panel	11
7.1.1	Invocation	11
7.1.2	Password	12
7.1.3	Navigation principle	13
7.1.4	Lowest menu level: select values, enter numbers	14
7.2	Unit	15
7.3	Sensor	16
7.3.1	Excitation, Sensitivity, Cell rating	18
7.3.2	Rate, Cell error, Smoothing	19
7.4	Calibration	21
7.4.1	Zero point	22
7.4.2	Adjust without mechanical load	22
7.4.3	Adjust with mechanical load	22
7.4.4	Adjust	22
7.4.5	Notes on zero point and Adjust	23
7.4.6	Range	24
7.4.7	kg/unit	24
7.5	Triggers	25

<b>7.6</b>	<b>Relays</b> .....	<b>26</b>
7.6.1	Trip alarm .....	27
7.6.2	Operating behaviour .....	28
7.6.3	Trip point and Hysteresis .....	29
7.6.4	Delay .....	30
7.6.5	Alarm freeze and Hold on error .....	31
7.6.6	Fault indication .....	31
<b>7.7</b>	<b>Current output</b> .....	<b>32</b>
7.7.1	Gross/Net, Span, Inverted .....	33
7.7.2	Characteristic .....	34
7.7.3	Fault current .....	36
<b>7.8</b>	<b>Service</b> .....	<b>37</b>
<b>7.9</b>	<b>Factory settings</b> .....	<b>38</b>
<b>8</b>	<b>RS 485 interface</b> .....	<b>40</b>
<b>9</b>	<b>Example</b> .....	<b>43</b>
9.1	Unit .....	43
9.2	Sensor data .....	44
9.3	Trigger inputs .....	45
9.4	Calibration .....	45
9.5	Outputs .....	46
9.6	Operation .....	46

## 1 Symbols used in this document



Warning

*This symbol indicates a warning about a possible danger.*

*Failure to observe this warning may result in personal injury or death, or property damage or destruction.*



Attention

*This symbol warns of a possible fault.*

*If the instruction given in this warning is not heeded, the device and any plants or systems connected to it could develop a fault or even fail completely.*



Note

*This symbol brings important information to your attention.*

## 2 Overview

The devices of the K-System from Pepperl+Fuchs are used to transmit signals between field devices and the process control system or control.

Devices with the "Ex" code in their type identifiers are suitable for connection to field devices in the hazardous area. The field current circuits of these devices are intrinsically safe and are galvanically isolated from the not intrinsically safe circuits. The devices thus represent an electrical isolation between the hazardous area and the secure area.

Devices without an Ex code can be used for signal transmission between field devices in the secure area and the process control system or the control.

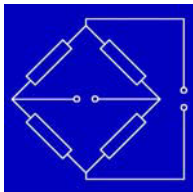

Resistance bridges, i. e. strain gauges, load cells, force transducers, pressure transducers, torque shafts or similar devices, can be connected to the input of the converters KFD2-WAC2-(Ex)1.D of the K-System (referred to as WAC2).

The WAC2 converts the input signal into a proportional output current, which can be forwarded e. g. to a display unit or an analog input of the process control system or control. By means of the two relay outputs of the WAC2, two different, freely parameterisable trip values of the input signal can be monitored.

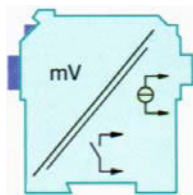

Further information (e. g. certificates and the WAC2 data sheet and the operating instructions for the K-System) can be found on our Internet page [www.pepperl-fuchs.com/pa](http://www.pepperl-fuchs.com/pa) (under Product search, enter \*WAC2\*).

### 3 Safety instructions



Warning

*The converters KFD2-WAC2-(Ex)1.D may only be operated by trained personnel in a manner corresponding to this operating manual.*



Warning

*Protection of operating personnel and the installation is only guaranteed if the devices are used according to their specifications. Any use other than that described in the manual endangers the safety and functionality of the device and the system in which it is installed.*



Warning

*The devices may only be installed, connected and adjusted by electrical professionals outside the explosion hazardous area.*



Warning

*If malfunctions cannot be avoided, place the devices out of service and protect them from accidental use. The devices may only be repaired directly by the manufacturer Pepperl+Fuchs. Any opening or change in the units are dangerous and are therefore not to be performed. They void any warranty.*



Note

*Responsibility for adhering to local safety regulations and directives is held by the operator.*

## 4 Explosion protection

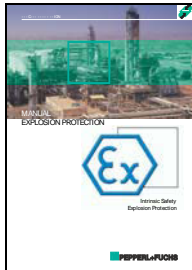

For primary explosion protection, that is, measures to avoid or restrict the production of a dangerous, explosive atmosphere, please consult the directive 94/9/EC or the corresponding national provisions.

For secondary explosion protection, that is, measures to avoid the ignition of a surrounding explosive atmosphere by electrical equipment, Pepperl+Fuchs will gladly provide you with a copy of the "Ex-protection manual" for a nominal fee.

Please pay particular attention to EN 60079-0, EN 60079-11 and EN 60079-26 or to the corresponding national provisions.

Pepperl+Fuchs also provides a seminar on the topic of explosion protection.

### 5 Mounting and connection

#### 5.1 Mounting



Attention

*The converters KFD2-WAC2-(Ex)1.D are constructed in protection class IP20 and must therefore be protected from undesirable environmental conditions (water, small foreign objects).*

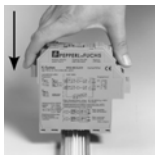

The devices of the K-System from Pepperl+Fuchs and thus also the converters KFD2-WAC2-(Ex)1.D can be mounted on a 35 mm standard rail corresponding to EN 50022. The devices must be snapped onto the rail **vertically**, and never slanted or tipped to the side.

Further mounting alternatives, e. g. using the Power Rail, can be found in the operating instructions for the K-System on our Internet page [www.pepperl-fuchs.com/pa](http://www.pepperl-fuchs.com/pa) (under Product search, enter "WAC2").

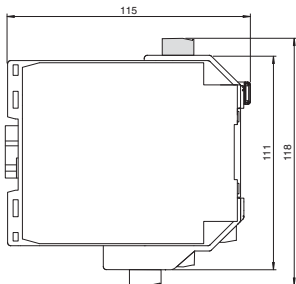
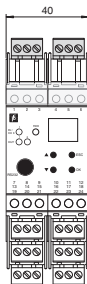

Dimensions of the  
KFD2-WAC2-(Ex)1.D in mm



### 5.2 Connection

The KF series' slip-off terminals significantly simplify connection and construction of switching cabinets. They allow quick and error-free exchange of the unit when service is needed.

The terminals can be screwed on, are self-opening, and have generous connection room for a wire diameter of up to 2.5 mm<sup>2</sup> and coded plugs, so that leads cannot be confused.



The intrinsically safe field circuit is connected to the **blue** terminals 1 to 6 of the KFD2-WAC2-Ex1.D. This may be conducted into the hazardous area using DIN EN 60079-14-compliant leads.

The non-intrinsically safe field circuit is connected to the **green** terminals 1 to 6 of the KFD2-WAC2-1.D.

In both cases you can connect:

- a half bridge (terminals 1, 3, 4, 5, 6)
- a full bridge (terminals 1 to 6)

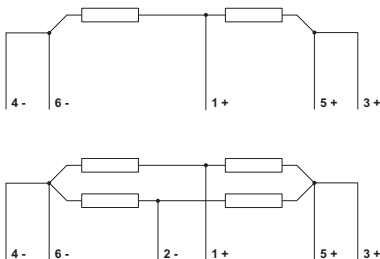

The remaining green terminals have the following functions:

- Terminals 7/8: current output
- Terminal 9: only for voltage output (see below.)
- Terminals 10 ... 12: relay 1
- Terminals 13/14: binary input 1
- Terminals 15/14: binary input 2
- Terminals 16 ... 18: relay 2
- Terminals 19 ... 21: RS 485 interface (deactivated if plug is in RS 232 interface)
- Terminal 22: not used
- Terminals 23/24: power supply 24 V DC

If you connect terminals 7 and 9 by means of a bridge, a voltage output of - 10 V ... + 10 V results between this bridge and terminal 8. The built-in shunt resistance is 500  $\Omega$ .

The RS 485 interface is galvanically isolated from other circuits. It is deactivated if you plug a connector into the socket of the RS 232 interface on the front panel of the WAC2. Please note the description in section 8.

Further information on connecting the WAC2 (e. g. on using the Power Rail) can be found in the data sheet and in the operating instructions for the K-system on our Internet page [www.pepperl-fuchs.com/pa](http://www.pepperl-fuchs.com/pa) (under product search, enter \*WAC2\*).

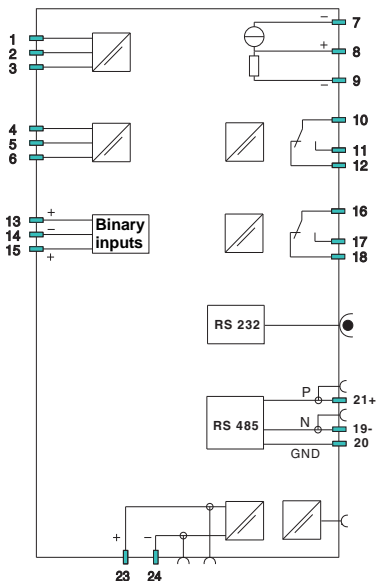

### 5.3 Front panel

On the front panel of the WAC2 you will find:

- LED ERR (red) to indicate
  - a sensor fault (flashes red)
  - the simulation mode (only when using **PACT<sub>wire</sub>**<sup>TM</sup>, flashes red)
  - a device fault (steady red)

For information on the error messages, see section 6.

- PWR LED (green), to indicate the presence of the supply voltage
- LED OUT 1 (yellow), to indicate that relay 1 is active
- LED OUT 2 (yellow), to indicate that relay 2 is active
- a display for measured value and error message display and for display during parameterisation mode
- four buttons for parameterisation of the WAC2
  - ▲ (Up)
  - ▼ (Down)
  - ESC (Escape)
  - OK
- Interface for connecting a computer for parameterization and diagnostics of the device with the **PACT<sub>wire</sub>**<sup>TM</sup> operating software, using the K-ADP-USB adapter

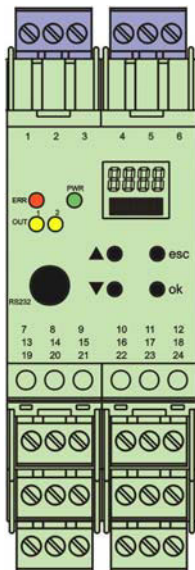

## 6 Display mode and error messages

### Measured value display

- In normal operation, the current net value is indicated on the display in the selected unit.
- If you hold down the ▼ key, the current gross value is indicated on the display in the selected unit.
- If you hold down the ▲ key, the mV value actually measured by the WAC2 on the terminals 1 and 2 is indicated on the display.

### Explanations

- For information on selecting the unit, see section 7.2.
- For information on the conversion of the mV measured value into the gross value, see section 7.3.1 and 7.4.4.
- As usual, the following applies: net value = gross value - tare
- For information on determining the tare, see section 7.5.

### Messages during operation

- *Alarm freeze*
- *Hold on error*

For information on these functions, see section 7.6.5.

### Error messages

- *Err INT*: error in the internal communication of the WAC2; may also occur if no sensor is connected
- *Err MEM*: error in the memory of the WAC2
- *Err SIM*: WAC2 in simulation mode (only when using **PACT<sub>wire</sub>**<sup>TM</sup>)
- *Err CELL*: cell breakage or no cell connected; for information on selecting the check for sensor breakage, see section 7.3.2

If you cannot solve the problem by checking the cell and the cell cables and by switching the WAC2 off/on, please contact Pepperl+Fuchs.

In the case of a fault, the relays switch into a state with no current, unless you have selected the function *Hold on error* (see section 7.6.5). For information on the behaviour of the current output in the case of a fault, see section 7.7.3.

## 7 Editing device data



Warning

*Any change to device data will change the operation of the device!  
Before entering new data into the device, be sure that no danger to the installation will result.*



Note

*In this manual, the parameterisation of the device via the control panel is described.  
Parameterisation by means of a PC is more convenient.  
The necessary K-ADP-USB can be ordered from Pepper+Fuchs. The **PACTware™**  
operating software and the manual are available on our Internet page  
[www.pepperl-fuchs.com](http://www.pepperl-fuchs.com) under Software > PACTware.*

### 7.1 Parameterisation mode of the control panel

#### 7.1.1 Invocation

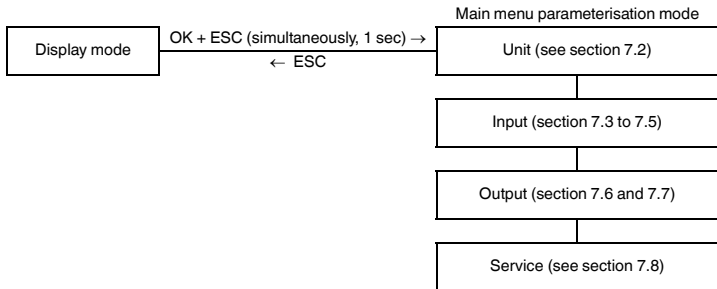

From any menu option of the parameterisation mode, you can return to the display mode by (if necessary repeatedly) pressing the ESC key. If 10 minutes elapse without a key being pressed in parameterisation mode, the device switches automatically back to display mode.

### 7.1.2 Password

You can protect the parameterisation from unauthorised changes by means of a password (see section 7.8; at the delivery of the WAC2, the password is inactive).

If the password protection is active, you can view the different settings in the parameterisation mode, but not change them before entering the password. On the first attempt to make a change, the device immediately prompts for a password.

The password must be entered for **each** transition from display mode to parameterisation mode, **once** each time.

The password cannot be changed. It is **1234**.

The password is entered as follows:

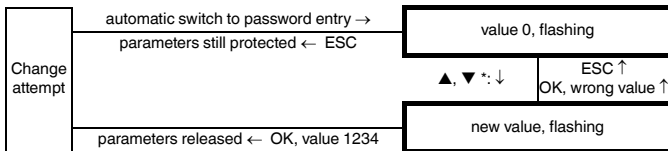

\*If you press the ▲ or ▼ key, the value changes step by step. If you hold the ▲ or ▼ key, the setting "rolls" to higher or lower values.

### 7.1.3 Navigation principle

The following figure shows the principle of navigation in the parameterisation mode by means of the ▲, ▼, OK and ESC keys:

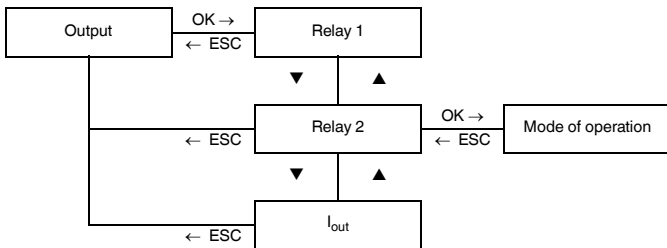

#### 7.1.4 Lowest menu level: select values, enter numbers

At the lowest menu level, you can either select from certain possible values for the individual parameters or enter a numerical value.

Proceed as follows:

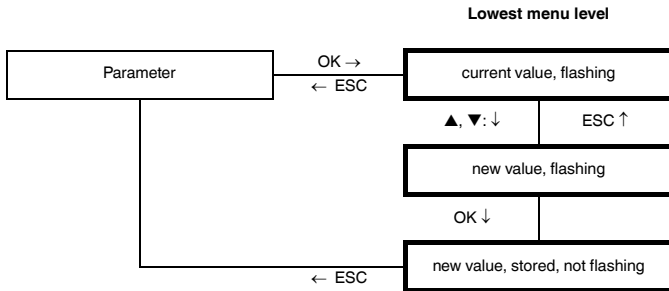

When entering **numerical values**, please observe the following:

- If you press the ▲ or ▼ key, the value changes step by step.
- If you hold the ▲ or ▼ key, the setting "rolls" to higher or lower values.
- The algebraic sign changes automatically.
- The decimal point is moved automatically.
- Units are automatically converted to higher units, e. g. kg to t, or a factor is displayed, e. g. factor 10 for numbers  $\geq 10000$ .



## 7.2 Unit

The following figure shows the menu for the unit. The menu options of the lowest menu level are surrounded by a bold box. The unit is used for the measured value display (net and gross) and for all respective settings in the parameterisation mode.

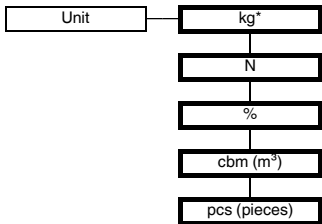

\* If more than 9999 kg are entered, the unit changes automatically from kg on t!

The WAC2 makes measurements in mV. For information on the conversion into other units, see section 7.3.1 and 7.4.4, for information on setting the tare, i. e. conversion of gross into net, see section 7.5.

### 7.3 Sensor

The following figures show the menus for the input parameters. The menu options of the lowest menu level are surrounded by a bold box. Menu options that are only displayed if you have selected certain parameter values elsewhere are highlighted in grey.

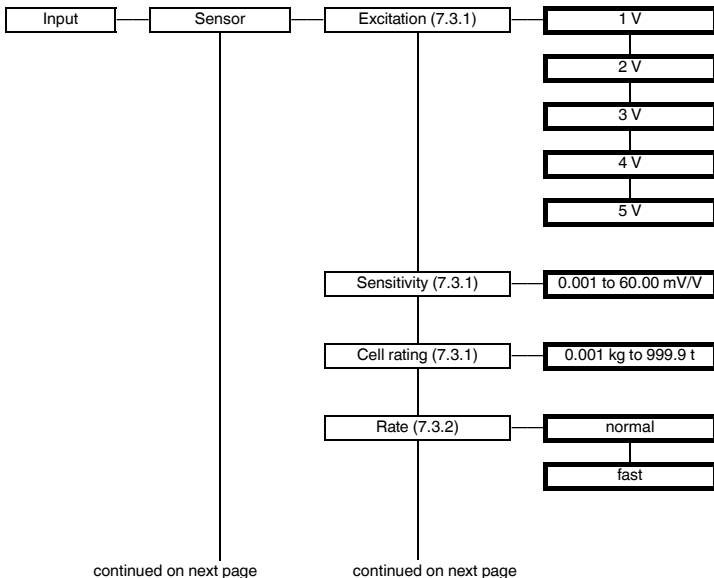

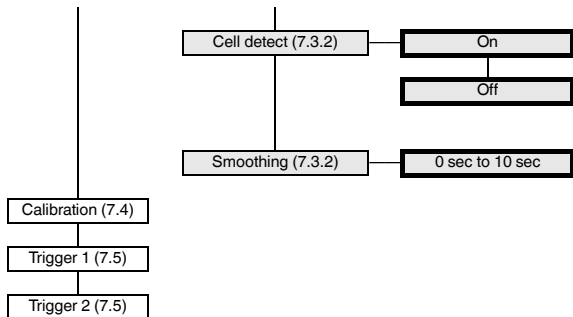

### 7.3.1 Excitation, Sensitivity, Cell rating

- For the values of these parameters, please refer to the technical data of the sensor.
- The supply voltage exists between terminals 3 and 4.
- When connecting several measuring cells in parallel, the supply voltage and sensitivity must be transferred, the cell data are to be totalled. Only cells of the same design and with identical cell data may be connected in parallel.
- For a resulting total sensor resistance of  $R < 100 \Omega$  the supply voltage 5 V must not be selected. The maximum permitted supply voltage is calculated as follows:  
Supply voltage = 49 mA x total resistance of the measuring cells
- For the *Cell data* parameter, the maximum cell load must be set in **kg** (even if a different unit has been selected).

The cell data can be set up without a measuring cell being connected. The WAC2 can then be connected to the weighing cell and is basically ready for operation. The voltage created by the weighing cell due to the load is converted linear into the corresponding gross weight.



Note

*If you want to use the WAC2 without calibration yet take into account an existing empty weight (e. g. an empty tank or a weighing platform) when measuring, do not use the function "Zero point" (section 7.4.1) but the function "Tare" as described in section 7.5.*

Please note that mechanical influences have not yet been taken into account (e. g. acting of forces on the weighing cell other than perfectly vertically) so that the weighing device does not achieve its optimum accuracy.



Note

*To take into account mechanical influences a calibration of the fully installed weighing device using defined loads is unavoidable (see section 7.4.4).*

**Without adjustment** (see section 7.4), the gross value is calculated as follows:

$$\text{Gross value} = \frac{\text{Measured value in mV}}{\text{Sensitivity} \times \text{Excitation voltage}} \times \frac{\text{Cell rating}}{\text{kg/unit}}$$

For information on selecting the *unit*, see section 7.2, for information on the *kg/unit* parameter, see section 7.4.7.

This results in the following assignment: 0 mV is converted into 0 unit, the maximum sensor signal (= sensitivity x excitation voltage) is converted into the maximum cell load of the selected unit, interim values are converted proportionally.

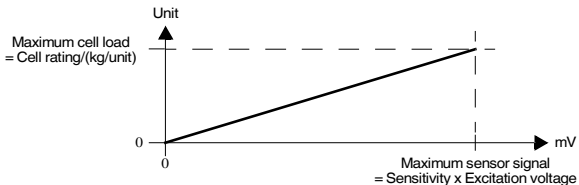

### 7.3.2 Rate, Cell error, Smoothing

- If you have selected the *fast* setting for *Rate*, the *Sensor failure* and *Smoothing* menu options are not displayed. In this case, a check for sensor breakage and smoothing is not possible.



*For the fast version (KFD2-WAC2-Ex.D-Y\*) the menu item sensor error does not appear.*



Note

- If you have selected the *On* setting for *Sensor failure*, a check for sensor breakage is performed after each measurement (terminals 1 and 2). Possibly, the WAC2 returns the error message *Err CELL*. Unless this check is enabled the WAC2 might process uncontrolled input values until the sensor failure has been detected.

- The settings influence the measuring cycle time:



### Hinweis

*For the fast version (KFD2-WAC2-Ex.D-Y\*) the following menu item appears Rate cannot be set or only set to "fast". The response time is then approx. 150 ms.*

Rate	Sensor failure	Measuring cycle time	Note
fast	–	approx. 150 ms	only Y*
fast	–	approx. 300 ms	not Y*
normal	Off	approx. 750 ms	not Y*
normal	On	approx. 850 ms	not Y*

- By means of *Smoothing*, you influence the reaction of the WAC2 to strongly fluctuating measured values.

The WAC2 processes the smoothed value instead of the current measured value. With an adjusted smoothing time of 0 sec, the input value is processed directly. The largest smoothing is reached with the attitude 10 sec. Note please that with increasing smoothing also the response time of the WAC2 is reduced.

Smoothing is designed as a first-order low-pass filter. The smoothing time is the time required by the output signal to get from 10 % to 90 % after a jump stimulation.

## 7.4 Calibration

The following figure shows the menu levels following the *Calibration* menu option. The menu options of the lowest menu level are surrounded by a bold box. Menu options that are only displayed if you have selected certain parameter values elsewhere are highlighted in grey.

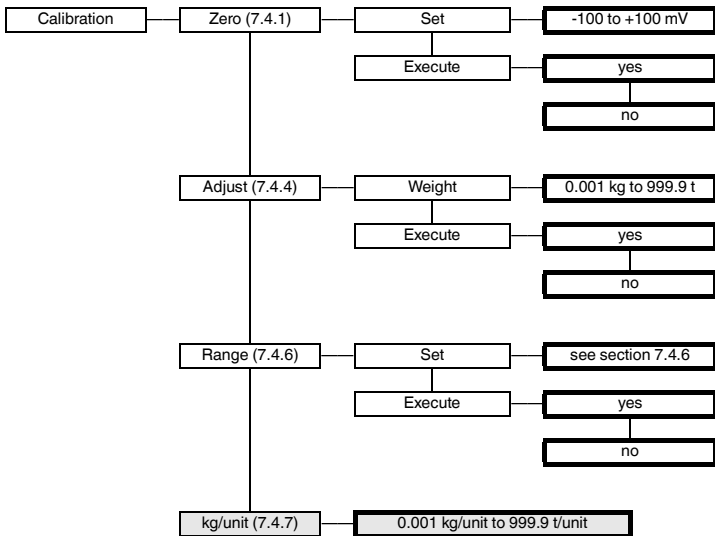

#### 7.4.1 Zero point

For installations where a signal of 0 mV does not correspond to the measured value 0 in the selected unit (see section 7.2), a zero offset can be stored.

- If the zero offset is known from the data of the installation, please enter the value under *Set displays*.
- If you select (after appropriate measures in the installation, e. g. removing all weights) *Execute* and then *Yes*, the current mV measured value is stored as zero point. The gross value, the net value and the tare (see section 7.5) are set to 0.

For storing the zero point by means of the triggers, i. e. without using the control panel keys, see section 7.5.

#### 7.4.2 Adjust without mechanical load

The easiest calibration method. However, not all links in the measuring chain will be considered resulting in some inaccuracies.

- A trigger input must be parameterised as tare (see section 7.5)
- After installation and connection of the WAC2 the corresponding input must be short-circuited with the measuring cell free from loads.

#### 7.4.3 Adjust with mechanical load

This is the more accurate calibration method because the whole measuring chain is included. It does, however, require a high effort.

#### 7.4.4 Adjust

The adjust is an exact defined excitation of the cell, e. g. by an exactly known weight. The WAC2 requires both the value of the adjust in the selected unit (see section 7.2) and the generated input signal in mV:

- First enter the adjust value in the selected unit *kg*, *N*, *cbm* or *pcs* under *Weight*. If you have selected the unit %, the adjust value must be entered in the unit that was selected before the unit was set to %.
- After excitation of the sensor (applying the weight), select *Execute* and then *Yes*. This determines the adjust value in mV. The tare (see section 7.5) is set to 0, gross value and net value correspond to the adjust value in the selected unit.

For determining the adjust value in mV by means of the triggers, i. e. without using the control panel keys, see section 7.5.



#### 7.4.5 Notes on zero point and Adjust

- For the result of the adjust it does not matter whether you determine the zero point or the adjust value first.
- Zero point and adjust value must be determined in the same unit (do not change the unit before **both** operations have been performed).
- If you perform the adjust in a unit other than kg, a new adjust is required after changing the value *kg/unit* (see section 7.4.7).
- If you change one of the *Excitation voltage*, *Sensitivity* or *Cell rating* parameters, a new adjust is required.

**After an adjust**, the gross value is calculated as follows:

$$\text{Gross value} = \frac{\text{Measured value in mV} - \text{Zero point}}{\text{Adjust in mV} - \text{Zero point}} \times \text{Adjust in unit}$$

This results in the following assignment: The zero point (in mV) is converted into 0 unit, the adjust value in mV is converted into the adjust value of the selected unit, intermediate values and values beyond the adjust value are converted proportionally:

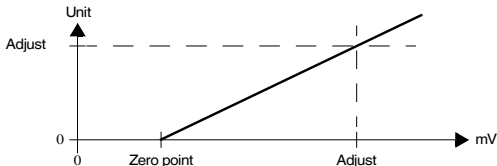

#### 7.4.6 Range

This parameter is required for evaluations in the unit %.

- Under *Set displays*, enter the value that is to correspond to the gross value 100 % in the (before selecting %) selected unit *kg*, *N*, *cbm* or *pcs* (see section 7.2). Values between 0 and the maximum cell load are possible (see section 7.3.1).
- Alternatively, you can select *Execute* and then *Yes* after excitation of the cell (e. g. after applying a corresponding weight). This stores the current measured value as *Range*.

**After a change to the unit %**, the gross value is calculated as follows:

$$\text{Gross value in \%} = \frac{\text{Gross value without change to \%}}{\text{Range}} \times 100 \%$$

#### 7.4.7 kg/unit

- This menu option is only displayed if *N*, *cbm* or *pcs* has been selected as unit (see section 7.2) or if % has been selected as unit and *N*, *cbm* or *pcs* has been selected previously.
- The entered value determines the conversion of kg into
  - N (approx.  $1/9.81 = 0.102$ )
  - cbm (known from the application or to be determined by weighing)
  - pcs (known from the application or to be determined by weighing).
- If % has been selected as unit, the factor for converting kg into the previously selected unit must be entered.
- If an adjust into a unit other than kg is performed, the value *kg/unit* must be entered **before** the adjust. After changing the value *kg/unit*, a new adjust is required.

## 7.5 Triggers

The following figure shows the menus for trigger 1 and trigger 2. The menu options of the lowest menu level are surrounded by a bold box. For information on the binary inputs, see also section 5.2.

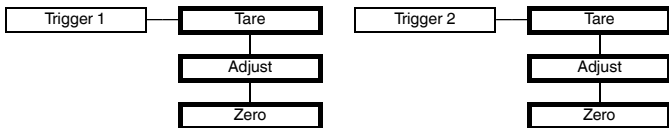

Binary input for trigger 1: terminals 13/14

Binary input for trigger 2: terminals 15/14

- In the case of the *Tare* setting, a signal of at least 100 ms at the binary input results in the current measured value of the WAC2 being stored as the (new) value for the tare. As usual, the following applies:  
$$\text{net value} = \text{gross value} - \text{tare}$$
- In the case of the *Adjust* setting, a signal of at least 100 ms at the binary input results in the current measured value of the WAC2 being adopted as the value for the adjust (see section 7.4.4).
- In the case of the *Zero* setting, a signal of at least 100 ms at the binary input results in the current measured value of the WAC2 being adopted as the value for the zero point (see section 7.4.1).

Storing the adjust and the zero point by means of the triggers only makes sense, for example, if you want to avoid operational actions on the WAC2.

## 7.6 Relays

The following figure shows the menus for the output parameters.

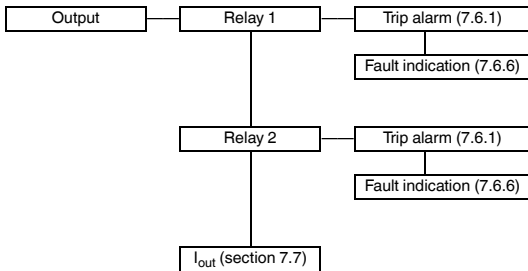

From the *Relay 1* and *Relay 2* menu options, you can use the OK key to get to a menu in which you can enter individual parameters for the selected relay. Both menus are structured in the same way and are thus only described once.

The activated function of a relay (*Trip alarm* or *Fault indication*) is marked by *On*. If you want to activate a different function, first call this function using the ▲ and ▼ keys. Then press the OK key twice. After the first OK you can cancel with ESC.

### 7.6.1 Trip alarm

The following figures show the menu levels following the *Trip alarm* menu option. The menu options of the lowest menu level are surrounded by a bold box.

If the Trip alarm function is activated (*On*), use the OK key to get from the *Trip alarm* menu option to the *Min/Max* menu option. If you reactivate the Trip alarm function (see section 7.6), pressing the OK key twice takes you directly to the *Min/Max* menu option.

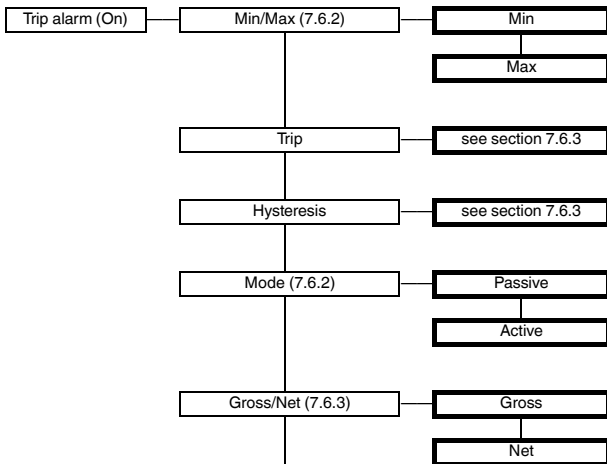

continued on next page

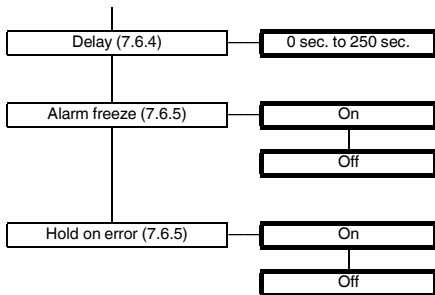

## 7.6.2 Operating behaviour

As the trip mode *Max* or *Min* are possible, as the operating mode *Active* or *Passive* are possible (see section 7.6.1). Areas of application:

- Trip mode *Max*, operating mode *Active*: alarm if the signal is above the trip value, e. g. horn on; protection against overfilling, e. g. open drain in capacity tank
- Trip mode *Max*, operating mode *Passive*: protection against overfilling, e. g. conveyor belt/pump off; for a large hysteresis Min-Max operation, e. g. conveyor belt/pump on/off
- Trip mode *Min*, operating mode *Active*: alarm if the signal is below the trip value, e. g. horn on; protection against shortfalls in security reserves, e. g. conveyor belt/pump on
- Trip mode *Min*, operating mode *Passive*: Protection against shortfalls in security reserves, e. g. pumping out off; for a large hysteresis Min-Max operation

The exact operating behaviour of the WAC2 is illustrated in the following figure:

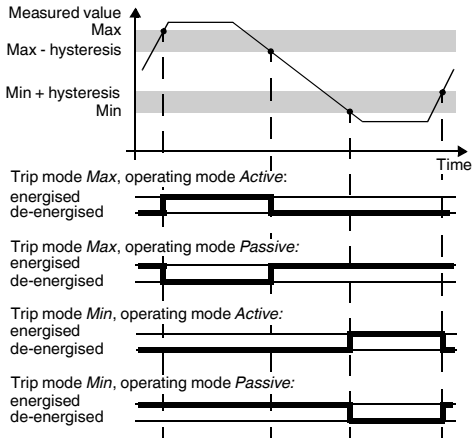

### 7.6.3 Trip point and Hysteresis

When entering the values for the trip point and hysteresis, please observe the following:

- By means of the *Gross/Net* parameter, you determine whether the value for the trip point is a gross value or a net value (gross value minus current tare, see section 7.5).
- The trip point and hysteresis must be entered in the selected unit (see section 7.2).
  - The minimum value for the trip point is 0, the minimum value for the hysteresis is 0.1.
  - If you have selected *Gross*, the maximum cell load (see section 7.3.1) is the maximum value for the trip point and hysteresis.
  - If you have selected *Net*, the value of the maximum cell load minus the current tare (see section 7.5) is the maximum value for the trip point and hysteresis.

- As the representation of the operating behaviour in section 7.6.2 shows, the following must apply:
  - for the trip mode *Max*: trip point - hysteresis  $\geq 0$
  - for the trip mode *Min*: trip point + hysteresis  $\leq$  upper limit of the trip pointThe limits are automatically determined by the WAC2.
- The hysteresis should be  $> 1\%$  of the trip point in order to prevent rapid switching of the relay.

#### 7.6.4 Delay

If you set a time  $> 0$  sec, you prevent short-time violations of the trip value from triggering an alarm.

- The relay only switches if the trip point is exceeded/fallen short of for a period that is longer than the delay time.
- The relay only switches back if the trip point  $\pm$  hysteresis is fallen short of/exceeded for a period that is longer than the delay time.
- If the trip point is exceeded/fallen short of for a short time, this does not have any effects.

The following figure shows the operating behaviour for the trip mode *Max*, operating mode *Active*.

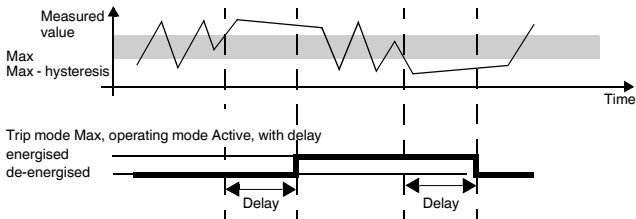



### 7.6.5 Alarm freeze and Hold on error

- By means of the **Alarm freeze** you ensure that the operating personnel notices if the trip value is temporarily violated.

If *Alarm freeze On* has been selected, the new condition is maintained after switching the relay, until the ESC key is pressed or the device is restarted. These actions reset the relay, unless the trip value is still exceeded.

- The **Hold on error** function prevents the relay from de-energising in the case of a fault.

If *Hold on error On* has been selected, the condition of the relay is maintained in the case of a fault (section 6), until the error message is cleared. Afterwards, the relay takes up its normal function again.

### 7.6.6 Fault indication

The following figure shows the menu levels following the *Fault indication* menu option. The menu options of the lowest menu level are surrounded by a bold box.

If the Fault indication function is activated (*On*), use the OK key to get from the *Fault indication* menu option to the *Alarm freeze* menu option. If you reactivate the Fault indication function (see section 7.6), pressing the OK key twice takes you directly to the *Alarm freeze* menu option.

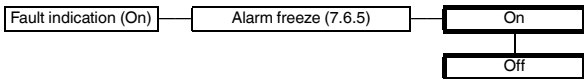

A relay with the function **Fault indication** is energised in normal operation. If the device detects a fault (see section 6), the relay is de-energised.

## 7.7 Current output

The following figures show the menu levels following the  $I_{out}$  menu option. The menu options of the lowest menu level are surrounded by a bold box.

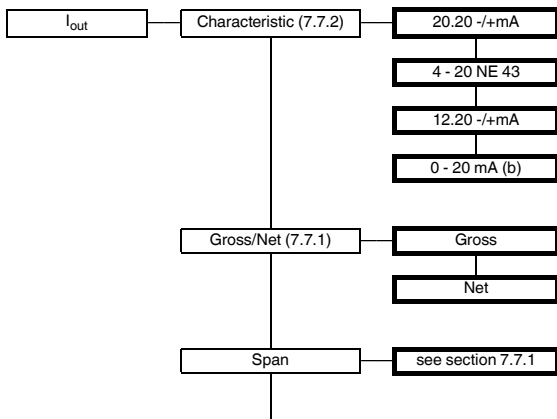

continued on next page

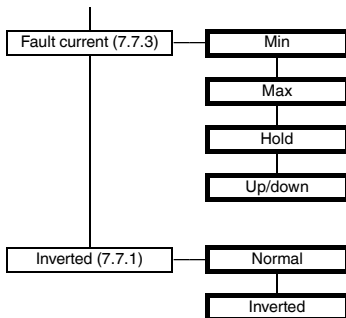

### 7.7.1 Gross/Net, Span, Inverted

- By means of the *Gross/Net* parameter, you determine whether the value for the *Span* is a gross value or a net value (gross value minus current tare, see section 7.5).
- By means of the *Span* parameter, you determine the measured value range which is represented by the current output (see section 7.7.2).
  - The span must be entered in the selected unit (see section 7.2).
  - If you have selected *Gross*, you can enter values between 1 % and 100 % of the maximum cell load (see section 7.3.1).
  - If you have selected *Net*, you can enter values between 1 % of the maximum cell load and the value of the maximum cell load minus the current tare.
- If you select *Inverted* → *normal*, the measured value 0 is converted into the start value of the current output and the *Span* is converted into the end value (for the WAC2 always +20 mA). If you select *Inverted* → *inverted*, the *Span* is converted into the start value of the current output and the measured value 0 is converted into the end value.

## 7.7.2 Characteristic

The settings have the following meaning (for *Inverted* → *normal*, see section 7.7.1):

### Selected setting 20.20 +/-mA

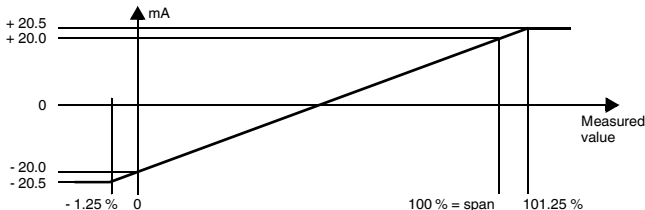

This setting converts the measured value 0 into -20 mA (i. e. into 20 mA in the case of changed polarity at the terminals 7 and 8; see section 5.2), the span (see section 7.7.1) is converted into +20 mA (terminal 7 -, terminal 8 +), interim values are calculated proportionally.

For values below the measured value 0, the output current decreases linearly to a minimum of -20.5 mA (-1.25 % of the measurement range). Further underflows cannot be evaluated (output -20.5 mA). If the span is exceeded, the output current increases linearly to a maximum of +20.5 mA (101.25 % of the measurement range). Further increases cannot be evaluated (output +20.5 mA).

### Selected setting 4 - 20 NE 43

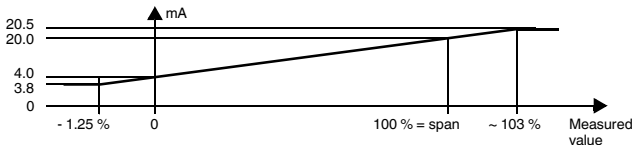

This setting converts the measured value 0 into 4 mA, the span (see section 7.7.1) is converted into 20 mA, interim values are calculated proportionally.

For values below the measured value 0, the output current decreases linearly to a minimum of 3.8 mA (-1.25 % of the measurement range). Further underflows cannot be evaluated (output 3.8 mA). If the span is exceeded, the output current increases linearly to a maximum of 20.5 mA (approx. 103 % of the measurement range). Further increases cannot be evaluated (output 20.5 mA).

### Selected setting 12.20 -/+mA

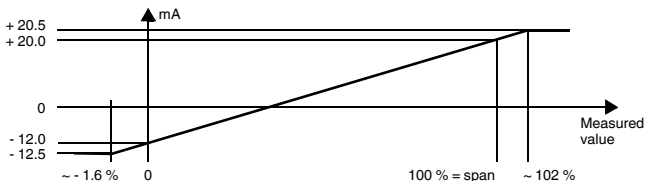

This setting converts the measured value 0 into -12 mA (i. e. into 12 mA in the case of changed polarity at the terminals 7 and 8; see section 5.2), the span (see section 7.7.1) is converted into +20 mA (terminal 7 -, terminal 8 +), interim values are calculated proportionally.

For values below the measured value 0, the output current decreases linearly to a minimum of -12.5 mA (approx. -1.6 % of the measurement range). Further underflows cannot be evaluated (output 12.5 mA). If the span is exceeded, the output current increases linearly to a maximum of 20.5 mA (approx. 102 % of the measurement range). Further increases cannot be evaluated (output 20.5 mA).

### Selected setting 0 - 20 mA (b)

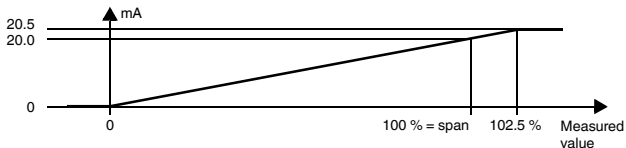

This setting converts the measured value 0 into 0, the span (see section 7.7.1) is converted into 20 mA, interim values are calculated proportionally.

Values below the measured value 0 cannot be evaluated (output 0 mA). If the span is exceeded, the output current increases linearly to a maximum of 20.5 mA (102.5 % of the measurement range). Further increases cannot be evaluated (output 20.5 mA).

### 7.7.3 Fault current

The following table shows what the current output is during a fault, depending on the selected setting (error messages see section 6):

Setting	Characteristic 20.20 +/-mA	Characteristic 4 - 20 NE 43	Characteristic 12.20 +/-mA	Characteristic 0 - 20 mA (b)
Min (downscale)	-21.5 mA	2.0 mA	-21.5 mA	0 mA (cannot be distinguished from measurement $\leq 0$ )
Max (upscale)	+21.5 mA	21.5 mA	+21.5 mA	21.5 mA
Hold	last value before the fault			
Up/down	in the case of Err Cell: downscale; in all other cases: upscale			

## 7.8 Service

The following figure shows the menus for the service parameters. The menu options of the lowest menu level are surrounded by a bold box.

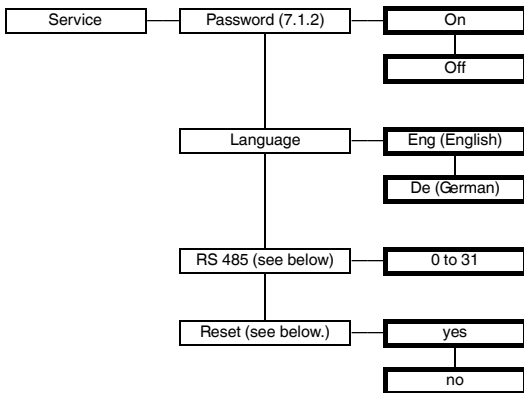

**RS 485:** Set the address of the WAC2 for communication via the RS 485 interface here (see section 8).

**Reset:** If yes is flashing and you press the OK key, all settings of the WAC2 will be reset to factory settings (see section 7.9; exceptions: language and password activation). All entries which you have ever made in parameterisation mode and the adjust will be lost.

## 7.9 Factory settings

Menu	Parameter	Factory setting	Local setting
Main menu	Unit	kg	
Input sensor	Excitation voltage	5 V	
	Sensitivity	2,000 mV/V	
	Cell rating	1000 kg	
	Rate	Normal	
	Cell error	On	
	Smoothing	0 sec.	
Input adjustment	Zero point	0.000 mV	
	Adjust	1000 kg	
	Range	1000 kg	
Input	Trigger 1	Zero	
	Trigger 2	Zero	
Output relay 1	Trip alarm	On (= selected)	
	MIN/Max (= Trip mode)	Max	
	Trip point	10.00 kg	
	Hysteresis	10.00 kg	
	Mode	Passive	
	Net/Gross	Net	
	Delay	0 sec.	
	Alarm freeze	Off	
Hold on error	Off		
	Fault indication	not selected	



<b>Parameter</b>	<b>Parameter</b>	<b>Factory setting</b>	<b>Local setting</b>
<i>Output relay 2</i>	<i>Trip alarm</i>	<i>On (= selected)</i>	
	<i>MIN/Max (= Trip mode)</i>	<i>Max</i>	
	<i>Trip point</i>	<i>10.00 kg</i>	
	<i>Hysteresis</i>	<i>10.00 kg</i>	
	<i>Mode</i>	<i>Passive</i>	
	<i>Net/Gross</i>	<i>Net</i>	
	<i>Delay</i>	<i>0 sec.</i>	
	<i>Alarm freeze</i>	<i>Off</i>	
	<i>Hold on error</i>	<i>Off</i>	
	<i>Fault indication</i>	<i>not selected</i>	
<i>Output <math>I_{out}</math></i>	<i>Characteristic</i>	<i>20.20 +/-mA</i>	
	<i>Net/Gross</i>	<i>Net</i>	
	<i>Span</i>	<i>20.00 kg</i>	
	<i>Fault current</i>	<i>Max</i>	
	<i>Inverted</i>	<i>Normal</i>	
<i>Service</i>	<i>Password</i>	<i>Off</i>	
	<i>Language</i>	<i>Eng</i>	
	<i>RS 485</i>	<i>1</i>	
	<i>Reset</i>	<i>no</i>	

## 8 RS 485 interface

The WAC2 can be connected to an RS 485 2-wire bus via the terminals 19 ... 21 or via the Power Rail (see section 5.2). In principle, such a bus is structured as follows:

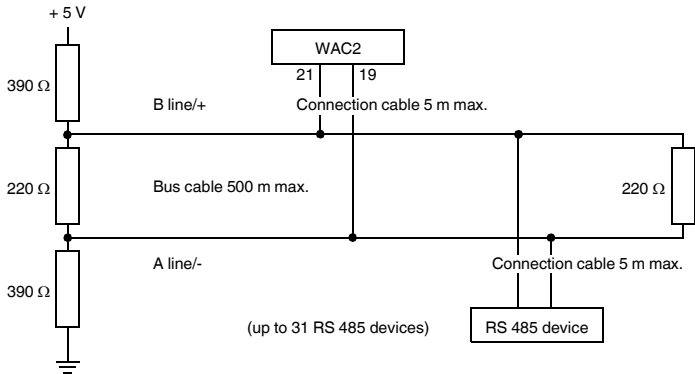

Attention

*Ensure that the polarity of the connection is correct!  
An incorrect polarity causes inverted data signals and thus prevents the bus from working properly.*

Characteristics of the RS 485 interface of the WAC2:

- Baud rate 9600
- 1 start bit, 8 data bits, no parity bit, 1 stop bit



Warning

*Requests via the RS 485 interface are **not** suitable for time-critical or safety-critical applications.*

The WAC2 can request the following information via the RS 485 interface e. g. from a PC or a PLC (with 3 decimal places each):

- Net measured value (in the set unit, see section 7.2)
- Gross measured value (in the set unit, see section 7.2)
- mV measured value (see section 7.2)
- Output value current output (in mA, see section 7.7.2)

The following commands are available for the requests:

- Null: delete the receive buffer of the requesting device
- Check\_1: checks whether WAC2 (with the respective address) is connected
- Get\_value\_ch1: requests the net measured value
- Get\_value\_ch2: requests the gross measured value
- Get\_value\_ch3: requests the mV measured value
- Get\_current: requests the output value current output



Note

*At the beginning of each RS 485 communication, send the request Check\_1.  
The RS 485 interface is deactivated if a connector is plugged into the programming jack (RS 232 interface) (see section 5.2).  
When the connector is removed, the request Check\_1 is required to switch to RS 485 communication.*

The commands must be encoded as follows:

Command	1 <sup>st</sup> byte	2 <sup>nd</sup> byte	3 <sup>rd</sup> byte	4 <sup>th</sup> byte	5 <sup>th</sup> byte	6 <sup>th</sup> byte
Null	0	0	0	0	0	0
Check_1	Address	1	Checksum			
Get_value_ch1	Address	B <sub>Hex</sub>	Checksum			
Get_value_ch2	Address	C <sub>Hex</sub>	Checksum			
Get_value_ch3	Address	10 <sub>Hex</sub>	Checksum			
Get_current	Address	D <sub>Hex</sub>	Checksum			

The WAC2 returns the following responses:

Command	1 <sup>st</sup> byte	2 <sup>nd</sup> byte	3 <sup>rd</sup> byte	4 <sup>th</sup> byte	5 <sup>th</sup> byte	6 <sup>th</sup> byte
Check_1	Address	9	Checksum			
Get_value_ch1	Address	Value				Checksum
Get_value_ch2	Address	Value				Checksum
Get_value_ch3	Address	Value				Checksum
Get_current	Address	Value		Checksum		

Explanations:

- Address: The address must be calculated as follows: 128 + setting under *Service* → *RS 485* (see section 7.8). Values from 128 + 0 to 128 + 31, i. e. from 10000000<sub>Bin</sub> to 10011111<sub>Bin</sub>, are possible.
- Checksum: The checksum is calculated as follows: 100<sub>Hex</sub> - (1<sup>st</sup> byte + ... + penultimate byte of the code), e. g. for Check\_1 for address 17: 100<sub>Hex</sub> - (91<sub>Hex</sub> + 1) = 6E<sub>Hex</sub> = 01101110<sub>Bin</sub>
- The figure 9 in the response to Check\_1 refers to the device type WAC2.
- Value: in the signed long data format (4 bytes or 2 bytes)

### 9 Example

The weight of a lorry load is to be calculated. The empty weight of the lorry can be between 7.5 t and 15 t, the load to be measured can be up to 20 t. To prevent an overloading of the lorry an alarm is to be triggered at a weight above 20.5 t.

The lorry rests on 4 weighing cells which have been connected in parallel at the input of the WAC2. Each weighing cell has the following data:

- Supply voltage 5 V
- Sensitivity 2 mV/V
- Maximum load: 15 t
- Internal resistance: 350  $\Omega$

The mass of the lorry weighing scales is 10 t.

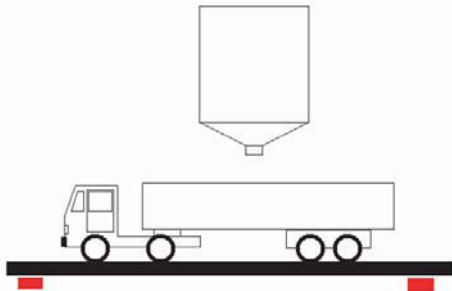

#### 9.1 Unit

The weight is to be displayed in the unit tons. In the menu **Unit** kg must be set. If the weight reaches 1000 kg the device automatically switches to t.

## 9.2 Sensor data

Because the lorry scale rests on 4 measuring cells the parameters of each individual measuring cell must be combined: The following entries must be made in the menu **Sensor**:

- **Supply voltage:**

Here the resulting total resistance of the parallel connection of the 4 sensors must be taken into account. If the resulting resistance of the sensors connected in parallel falls below  $100\ \Omega$ , a lower supply voltage must be selected due to the maximum available current. The maximum permitted supply voltage is calculated as follows:

Total resistance x 49 mA = maximum supply voltage

- 4 measuring cells with each  $350\ \Omega = 87.5\ \Omega$
- $87.5\ \Omega \times 49\ \text{mA} = 4.2875\ \text{V}$

Set the supply voltage to 4 V.

The maximum permitted total resistance of the sensors is 10 k $\Omega$ .

- **Sensitivity:**

The sensitivity of the individual cells can be accepted 1:1.

**Example:**

4 cells with 2 mV/V each, entry in Sensitivity = 2 mV/V

- **Cell data:**

Max. cell load: The cell load of the individual sensor must be multiplied by the number of sensors.

**Example:**

4 sensors with 15 t each, entry in Cell load = 60 tons).

**Explanation:**

If e. g. only one cell is loaded at its individual maximum load it will output its maximum voltage. The other 3 sensors are connected to this voltage and become consumers; this puts a load on the voltage source and results in a voltage drop. Only if all 4 cells are loaded at their respective maximum loads will they output their respective maximum voltages equally which is then measured in parallel by the WAC2. All uneven loads between those two extremes behave linear, therefore the parallel connection can be considered as a single measuring cell.

### 9.3 Trigger inputs

One trigger input must be parameterised as "Tare" to enable a subsequent zero point setup (see section 9.4 (offline calibration) and 9.6)

### 9.4 Calibration

The calibration can be carried out offline or online.

#### Offline

Calibration without mechanical load is the simplest way of calibrating the WAC2. However, inaccuracies are to be expected because the whole measuring chain is not included in the calibration process.

With an empty weighing device setting a zero point for the whole system is possible via the input parameterised as tare under "Trigger input". The characteristic of the weighing cell is retained and only the origin is adjusted.

The WAC2 is then calibrated. Because the measuring cells are normally calibrated at factory and are very strongly linear, the measuring values are calculated with great accuracy.

#### Online

The online calibration is more accurate than the offline calibration because it involves the whole measuring chain 100%. The measuring cell is put under a defined load and the WAC2 calibrated to these points.

The cell returns with an empty weighing platform 1.43 mV. In the menu item **Input > Calibration > Adjust > Zero point > Execute** a zero point calibration is carried out, i. e. the 1.43 mV are allocated to 0 kg which is now also displayed by the WAC2.

A defined weight must then be placed on the cell, e. g. 5 t.

Under the menu item **Input > Calibration > Adjust > Weight** the applied weight must now be entered (5 t) and the calibration be carried out via **Execute**. The WAC2 now displays 5 t.

The processes **Zero point calibration** and **Adjust** must always be carried out together, but the sequence described above does not have to be adhered to (it is possible to calibrate **Adjust** and then **Zero point**).

However, because the total mass to be measured is greater, the range must also be entered. Under **Input > Calibration > Range > Set** the weight to be measured must be entered, in the example 35 t. With this setting the value 100 % will be displayed at 35 t if the unit is changed to %.

The WAC2 has now been calibrated including the whole measuring chain.

## 9.5 Outputs

### Current output

The current output must only represent the net value (the weight of the load). In the menu **Output > I<sub>out</sub> > Gross/Net** the option **Net** must therefore be selected.

The adjustable range relates to the maximum cell load. Because the maximum cell load is not reached with a full tank (full lorry = 20 t, maximum cell load = 60 t) the value 20 t must be entered here.

### Relay outputs

To prevent overloading a relay must be triggered as a limit value relay if 20.5 t is exceeded. This means that the relay must be parameterised as a limit value switch with the switching direction "Max"; as a switching point the 20.5 t must be entered. As hysteresis a value of approx. 1 % of the range is recommended, i. e. 250 kg (0.25 t). The relay must energise once the switching point has been exceeded, the direction of action must therefore be entered as "active".

To prevent the relay from switching during the lorry entering the scales a time of 60 s can be entered under the menu item **Relay > Trip alarm > Delay**. Limit overruns of less than 60 s duration will then be ignored.

## 9.6 Operation

An empty lorry enters the scales. After short-circuiting the inputs of the trigger input previously parameterised as "Tare" a zero point calibration is carried out. The lorry is then loaded and the WAC2 displays only the weight of the load.

At the current output the weight of the load is represented by 4 mA for the empty lorry and 20 mA for the fully loaded lorry.

Via the RS 485 interface the weight of the load (net weight) can be queried by a PLS via the command **Get\_value\_ch\_1** and be processed numerically.









# PROCESS AUTOMATION – PROTECTING YOUR PROCESS



## Worldwide Headquarters

Pepperl+Fuchs GmbH  
68307 Mannheim · Germany  
Tel. +49 621 776-0  
E-Mail: [info@de.pepperl-fuchs.com](mailto:info@de.pepperl-fuchs.com)

For the Pepperl+Fuchs representative  
closest to you check [www.pepperl-fuchs.com/contact](http://www.pepperl-fuchs.com/contact)

[www.pepperl-fuchs.com](http://www.pepperl-fuchs.com)

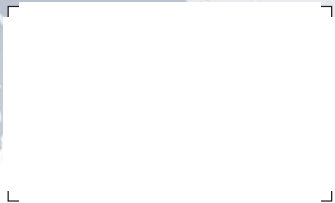

 **PEPPERL+FUCHS**  
*PROTECTING YOUR PROCESS*

Subject to modifications  
Copyright PEPPERL+FUCHS · Printed in Germany

281129

DOCT-0747G

07/2015