

MANUAL

Fieldbus Surge Protector

TPH-LBF-IA1.36*

TCP-LBF-IA1.36*

SCP-LBF-IA1.36*



With regard to the supply of products, the current issue of the following document is applicable: The General Terms of Delivery for Products and Services of the Electrical Industry, published by the Central Association of the Electrical Industry (Zentralverband Elektrotechnik und Elektroindustrie (ZVEI) e.V.) in its most recent version as well as the supplementary clause: "Expanded reservation of proprietorship"

1	Safety	4
1.1	Validity	4
1.2	Symbols used	4
1.3	System Operator and Personnel	4
1.4	Pertinent Laws, Standards, Directives, and further Documentation	5
1.5	Marking	5
1.6	Intended Use	6
1.7	Mounting and Installation	6
1.7.1	Intrinsically Safe Circuits	6
1.8	Repair and Maintenance	8
1.9	Delivery, Transport and Storage	8
1.10	Disposal	8
2	Product Specifications	9
2.1	Overview and Application	9
2.1.1	Cable Shield Grounding Options	10
2.1.2	Surge Protector Diagnostics	11
2.1.3	Status and Error Messages	11
2.1.4	Compatibility for Surge Protector Diagnostics	11
2.2	Component Identity	12
2.2.1	Protection of Segment Protector	13
2.2.2	Protection of Power Hubs	14
2.3	Technical Data	15
2.3.1	TPH-LBF-IA1.36.DE.*	15
2.3.2	TCP-LBF-IA1.36.IE*	16
2.3.3	SCP-LBF-IA1.36.IE.*	17
2.4	Dimensional Drawings	18
2.4.1	TCP-LBF-IA1.36.IE*	18
2.4.2	Surge Protector SCP-LBF-IA1.36.IE*	18
2.4.3	Surge Protector TPH-LBF-IA1.36.DE*	19
3	Installation	20
3.1	Installation of Surge Protector	20
3.2	Mounting and Dismounting	20
3.2.1	Surge Protector TCP-LBF-IA1.36.IE* for Trunk Connection	20
3.2.2	Surge Protector SCP-LBF-IA1.36.IE* for Spur Connection	25
3.2.3	Surge Protector TPH-LBF-IA1.36.DE* Trunk Connection for Power Hub	28
4	Appendix	32
4.1	Ordering Information	32



1 Safety

1.1 Validity

The chapter "Safety" is valid as instruction manual.

Specific processes and instructions in this document require special precautions to guarantee the safety of the operating personnel.

1.2 Symbols used

This document contains information that you must read for your own personal safety and to avoid property damage. Depending on the hazard category, the warning signs are displayed in descending order as follows:

Safety-relevant symbols



Danger!

This symbol indicates an imminent danger.

Non-observance will result in personal injury or death.



Warning!

This symbol indicates a possible fault or danger.

Non-observance may cause personal injury or serious property damage.



Caution!

This symbol indicates a possible fault.

Non-observance could interrupt devices and any connected facilities or systems, or result in their complete failure.

Informative symbols



Note!

This symbol brings important information to your attention.



Action

This symbol indicates a paragraph with instructions.

1.3 System Operator and Personnel

The plant owner is responsible for its planning, installation, commissioning, operation, maintenance and disassembly.

Mounting, installation, commissioning, operation, maintenance and disassembly of any devices may only be carried out by trained, qualified personnel. The instruction manual must be read and understood.

1.4 Pertinent Laws, Standards, Directives, and further Documentation

Laws, standards, or directives applicable to the intended use must be observed. In relation to hazardous areas, Directive 1999/92/EC must be observed.

The corresponding data sheets, declarations of conformity, EC Type-examination certificates, certificates and Control Drawings if applicable (see data sheet) are an integral part of this document. You can find this information under www.pepperl-fuchs.com.

Due to constant revisions, documentation is subject to permanent change. Please refer only to the most up-to-date version, which can be found under www.pepperl-fuchs.com.

1.5 Marking

The Surge Protectors are marked with:

Pepperl+Fuchs GmbH

Lilienthalstrasse 200, 68307 Mannheim, Germany

TPH-LBF-IA1.36.DE.0
TPH-LBF-IA1.36.DE.1

SIRA 12 ATEX 2128X

 II 1G Ex ia IIC T4

SIRA 12 ATEX 4176X

 II 3G Ex nAc IIC T4 ,

 II 3G Ex ic IIC T4

TCP-LBF-IA1.36.IE.0
TCP-LBF-IA1.36.IE.1

SIRA 12 ATEX 2128X

 II 1G Ex ia IIC T4

SIRA 12 ATEX 4176X

 II 3G Ex nAc IIC T4 ,

 II 3G Ex ic IIC T4

SCP-LBF-IA1.36.IE.0
SCP-LBF-IA1.36.IE.1

SIRA 12 ATEX 2128X

 II 1G Ex ia IIC T4

SIRA 12 ATEX 4176X

 II 3G Ex nAc IIC T4 ,

 II 3G Ex ic IIC T4

Electrical data see EC-type-examination certificate or datasheet.

1.6 Intended Use

The TPH-LBF*, TCP-LBF* and SCP-LBF* series of Surge Protectors are intended to be used in conjunction with Pepperl+Fuchs Fieldbus Power Hubs and Device Couplers, to protect them from damage caused by surge voltages or secondary lightning strikes. The Surge Protectors are specifically designed for IEC 61158-2 FOUNDATION fieldbus and PROFIBUS PA fieldbus communication systems.

The device is designed for use in intrinsically safe fieldbus systems according to FISCO, Entity, or DART.

The devices are only approved for appropriate and intended use. Ignoring these instructions will void any warranty and absolve the manufacturer from any liability.

The device must only be operated in the ambient temperature range and at the relative humidity (non-condensing) specified.

1.7 Mounting and Installation

The installation instructions in accordance with IEC/EN 60079-14 must be observed.

Prior to mounting, installation, and commissioning of the device you should make yourself familiar with the device and carefully read the instruction manual.

If devices have already been operated in general electrical systems, they may subsequently no longer be installed in electrical systems used in combination with hazardous areas.

If "Ex i" protected circuits (intrinsically safe) were operated with non-intrinsically safe circuits, they must no longer be used as "Ex i" protected circuits.

Avoid electrostatic discharges while operating the installed device. Avoid electrostatic charge.

The devices must be installed and operated only in enclosures that

- comply with the requirements for enclosures according to IEC/EN 60079-0
- are rated with the degree of protection IP54 according to IEC/EN 60529

1.7.1 Intrinsically Safe Circuits

The device may be installed in Zone 1.

The device may be installed in gas groups IIC, IIB and IIA.

All separation distances between two adjacent intrinsically safe circuits need to be observed in accordance with IEC/EN 60079-14.

Instructions for Zone 0

If the cable is led into Zone 0, the cable length must be limited to 1 m.

If the cable is led into Zone 0, the cable must be protected against interferences deriving from lightning.

The shield of the cable may only be led into Zone 0 if it is safely grounded like an equipotential bonding conductor according to IEC/EN 60079-14.

The cables connected to the device must be shielded, or covered by a metal coating, or passed within a metal pipe.

The surge protection devices do not meet the dielectric strength requirements according to EN 60079-11 between the intrinsically safe circuits and the parts that may be earthed, due the presence of gas discharge tubes.

Instructions for Zone 1

The surge protection devices do not meet the dielectric strength requirements according to EN 60079-11 between the intrinsically safe circuits and the parts that may be earthed, due the presence of gas discharge tubes.

Instructions for Zone 21

The surge protection devices do not meet the dielectric strength requirements according to EN 60079-11 between the intrinsically safe circuits and the parts that may be earthed, due the presence of gas discharge tubes.

Instructions for Zone 2

Connection or disconnection of energized non-intrinsically-safe circuits is only permitted in the absence of a hazardous atmosphere.

If the Surge Protectors are used on couplers spurs rated as Ex ic intrinsically safe circuit, the trunk module TCP-LBF-IA1.36.* with mounted separation wall must be used.

The surge protection devices do not meet the insulation from earth or frame requirements according to EN 60079-15, due the presence of gas discharge tubes.

The surge protection devices do not meet the dielectric strength requirements according to EN 60079-11 between the intrinsically safe circuits and the parts that may be earthed, due the presence of gas discharge tubes.

The field wiring connections must either be mechanically secured or must have a holding force of at least 15 N.

This could be achieved by using the connector from the fieldbus coupler or Power Hub a Surge Protector will be used with.

Instructions for Zone 22

Connection or disconnection of energized non-intrinsically-safe circuits is only permitted in the absence of a hazardous atmosphere.

If the Surge Protectors are used on couplers spurs rated as Ex ic intrinsically safe circuit, the trunk module TCP-LBF-IA1.36.* with mounted separation wall must be used.

The surge protection devices do not meet the insulation from earth or frame requirements according to EN 60079-15, due the presence of gas discharge tubes.

The surge protection devices do not meet the dielectric strength requirements according to EN 60079-11 between the intrinsically safe circuits and the parts that may be earthed, due the presence of gas discharge tubes.

The field wiring connections must either be mechanically secured or must have a holding force of at least 15 N.

This could be achieved by using the connector from the fieldbus coupler or Power Hub a Surge Protector will be used with.

1.8 Repair and Maintenance

The devices must not be repaired, changed or manipulated. If there is a defect, the product must always be replaced with an original device.

1.9 Delivery, Transport and Storage

Check the packaging and contents for damage.

Check if you have received every item and if the items received are the ones you ordered.

Keep the original packaging. Always store and transport the device in the original packaging.

Always store the device in a clean and dry environment. The permitted storage temperature (see data sheet) must be considered.

1.10 Disposal

Disposing of devices, packaging material, and possibly contained batteries must be in compliance with the applicable laws and guidelines of the respective country.

2 Product Specifications

2.1 Overview and Application

The FieldConnex[®] Surge Protector series TPH-LBF*, TCP-LBF* and SCP-LBF* protect fieldbus components and control units from damage caused by voltage surges and secondary lightning strikes. Surge voltages between the fieldbus wire (plus and minus) and between either wire and ground will be safely limited in an 'over-voltage' event.

Versions are available where the cable shield is either directly connected to earth or indirectly through a gas discharge tube. The Surge Protectors are designed for use in fieldbus communication topologies according to IEC 61158-2. They conform to IEC 60079-11: FISCO and Entity concepts and are also "DART Intrinsically Safe Compatible" (models without diagnostics). The Surge Protectors allow the coordinated use in an "EMC-orientated Lightning Protection Zones Concept", in accordance with IEC 61312-1. The protective effect is adapted to the EMC interference immunity (conducted high-energy interference impulses) for fieldbus measuring, control, and equipment.

The TPH-LBF*, TCP-LBF*, and SCP-LBF* series Surge Protectors consist of pluggable units, designed to fit directly into 3-pin terminals socket of Pepperl+Fuchs fieldbus components as Power Hubs, Segment Protectors and FieldBarriers, to protect trunk and spur connections of a fieldbus installation. This leads to a significant reduction in design and installation time/cost and significantly reduces the overall equipment footprint.

Specific versions of Surge Protectors include a unique diagnostic function for predictive maintenance of the Surge Protectors themselves. Predictive failures are communicated through Pepperl+Fuchs advanced physical layer infrastructure to allow the maintenance engineer to change defected units, before they start to adversely influence fieldbus communication. The Pepperl+Fuchs advanced physical layer infrastructure is part of the fieldbus segments itself, thus not requiring a manually scheduled maintenance activity.

Equally, the modular 'insertion-connection' design allows existing equipment to easily be upgraded, simply by plugging in a Surge Protector module where the existing cables remain in the same place connected to the same terminals. This is also ideal for retrospectively fitting surge protection where required without the need to reroute cables or add any fixings.

The modular approach also allows simple replacement of faulty or failing surge protection modules with minimal effort and time, without interference to neighboring cables or equipment.

The Spur Surge Protectors fit directly onto an grounding rail (type ACC-LBF-EB.*) that is positioned under the module so that individual modules can be easily attached or disconnected without affecting neighboring cables, equipment or modules.

The following table gives an overview about types and their specific usage in combinations with Pepperl+Fuchs fieldbus components:

Type	Description	Shield connection	Predictive diagnosis	Hazardous area
TCP-LBF-IA1.36.IE.0	Surge Protector for trunk connections of R2-SP*, R3-SP* fieldbus couplers	Indirectly grounded through GDT	No diagnostics	Entity, FISCO, DART
TCP-LBF-IA1.36.IE.1	Surge Protector for trunk connections of R2-SP* fieldbus couplers	Indirectly grounded through GDT	Includes diagnostics	Entity, FISCO
TPH-LBF-IA1.36.DE.0	Surge Protector for trunk connections of MBHD-FB1-* and MBHC-FB-* Power Hubs	Directly grounded	No diagnostics	Entity, FISCO, DART
TPH-LBF-IA1.36.DE.1	Surge Protector for trunk connections of MBHD-FB* (except type MBHD-FB-D*) and MBHC-FB* Power Hubs	Directly grounded	Includes diagnostics	Entity, FISCO
SCP-LBF-IA1.36.IE.0	Surge Protector for spur connections of R2-SP*, R3-SP*, R4D0-FB* fieldbus couplers	Indirectly grounded through GDT	No diagnostics	Entity, FISCO
SCP-LBF-IA1.36.IE.1	Surge Protector for spur connections of R2-SP*, R4D0-FB* fieldbus couplers	Indirectly grounded through GDT	Includes diagnostics	Entity, FISCO

2.1.1 Cable Shield Grounding Options

Fieldbus supports several methods for cable shield grounding in order to accommodate differing plant references (see FOUNDATION Fieldbus “System Engineering Guideline” AG-181). The most common of the topologies uses a single point for grounding, where the cable shield is connected directly to a clean earth at the control room, whilst all other screens or shields throughout the segment are left open or floating.

Other topologies connect the cable shield at multiple points throughout the segment to earth in order to maximize protection against EMC disturbance.

Surge Protector type *-LBF-IA1.36.IE.* connects the shield indirectly through a gas discharge tube to earth, whilst type *-LBF-IA1.36.DE.* connects the shield directly to earth.

2.1.2 Surge Protector Diagnostics

Surge Protectors types *-LBF-IA1.36.*.1 contain a unique diagnostic function that predicts failures of Surge Protectors, before they adversely affect fieldbus communication or the segment voltages.

The Surge Protector diagnostics monitors, measures, and records any overvoltage event, then compares the events to a given algorithm to predict how many further overvoltage events can be tolerated, before the surge protection electronics fails or degrades to a point where it affects the fieldbus communication.

Surge protection electronics can tolerate a given number or frequency of activations at given levels of voltage, before they completely fail, during which time, the surge protection electronics will gradually degrade. The diagnostic electronics will log and compare any activation to an algorithm that will then decide if the surge protection electronics is reaching its 'end of effective life'. At this point, the diagnostic electronics generates an alarm that the Pepperl+Fuchs Advanced Diagnostics infrastructure receives, whereon this alarm will be transmitted to the system's maintenance or operator terminal, containing Pepperl+Fuchs Advanced Diagnostic Manager software. Additionally, at the Surge Protector, a visual alarm is given so that the failing unit, or units, can be quickly identified.

2.1.3 Status and Error Messages

The Surge Protector types *-LBF-IA1.36.*.1 incorporate a LED showing the health or status of the Surge Protector. A green flashing LED indicates that the Surge Protector is healthy. An overvoltage event will be shown as a single flash event of the red LED.

During power up, Surge Protectors with integrated diagnostics show the percentage of the headroom of surge events already used, before the Surge Protectors issue an alarm. Each single flash represents 10 % of used headroom. If the LED shows 10 consecutive red LED flashes, the exchange of the Surge Protector is required at some point before the next expected surge event.

2.1.4 Compatibility for Surge Protector Diagnostics

This predictive maintenance feature for the Surge Protectors is available in combination with the fieldbus coupler types R2-SP-IC*, R4D0-FB-IA*, and the Advanced Diagnostic Module type HD2-DM-A. Using the Surge Protectors in combination with the fieldbus coupler R2-SP-N*, a green/red LED locally on the device indicates the diagnostic information; in this instance, the diagnostic information is not transmitted to the Advanced Diagnostic Module.

2.2 Component Identity

To protect Pepperl+Fuchs Fieldbus Power Hubs and fieldbus couplers from damage caused by surge voltages or secondary lightning strikes, you can install the TPH-LBF*, TCP-LBF*, or SCP-LBF* Surge Protectors series.

The TCP-LBF* Surge Protectors protect the trunk connection and the SCP-LBF* Surge Protectors protect the spur connection of fieldbus couplers.

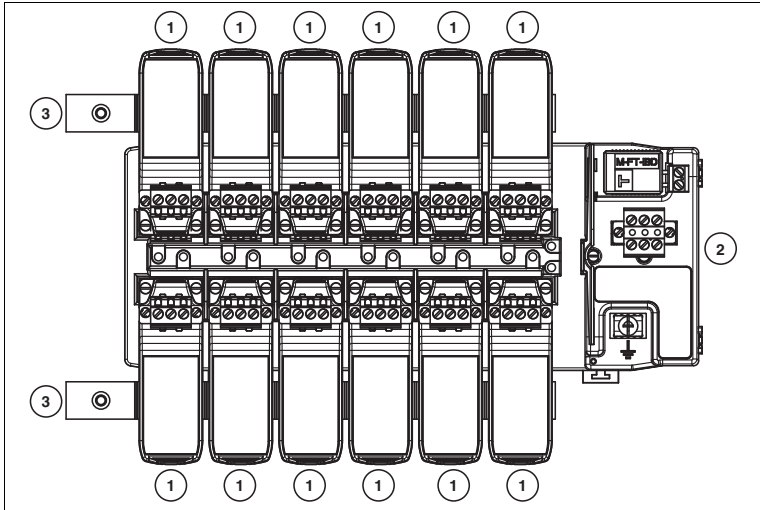

1. Surge Protector SCP-LBF*
2. Surge Protector TCP-LBF*
3. Grounding rail ACC-LBF-EB

The TCP-LBF* Surge Protectors protect the trunk connection of Power Hub Motherboards.

2.2.1 Protection of Segment Protector

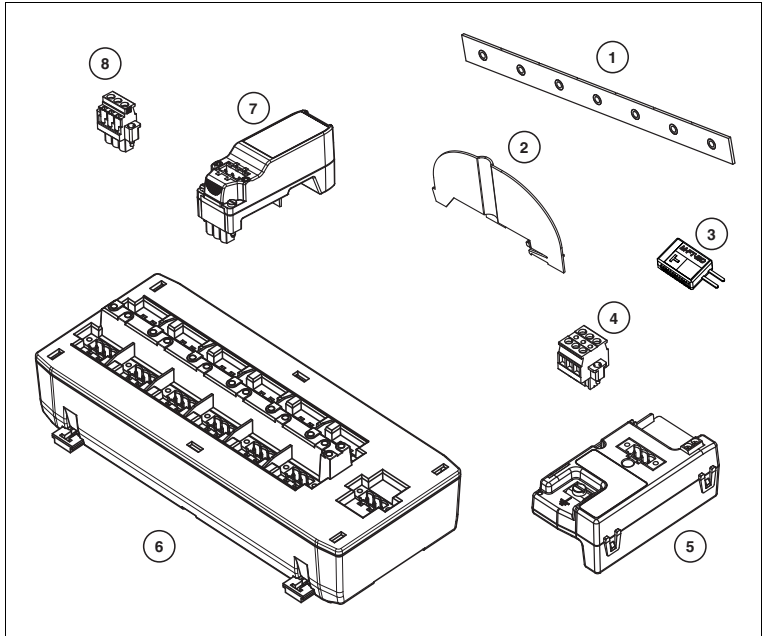

Figure 2.1

- 1 Grounding rail ACC-LBF-EB.6
- 2 Separation wall ACC-LBF-SW
- 3 Terminator M-FT*
- 4 T-connector
- 5 Surge Protector TCP-LBF-IA1.36.IE*
- 6 Segment Protector R2-SP-* or R3-SP-*
- 7 Surge Protector SCP-LBF-IA1.36.IE*
- 8 Spur connector

The Surge Protector TCP-LBF-IA1.36.IE* mounts on the trunk connection of the Segment Protector. See chapter 3.2.1

The Surge Protector SCP-LBF-IA1.36.IE* mounts on the spur connection of the Segment Protector. Use 1 Surge Protector for each spur terminal. See chapter 3.2.2

2.2.2 Protection of Power Hubs

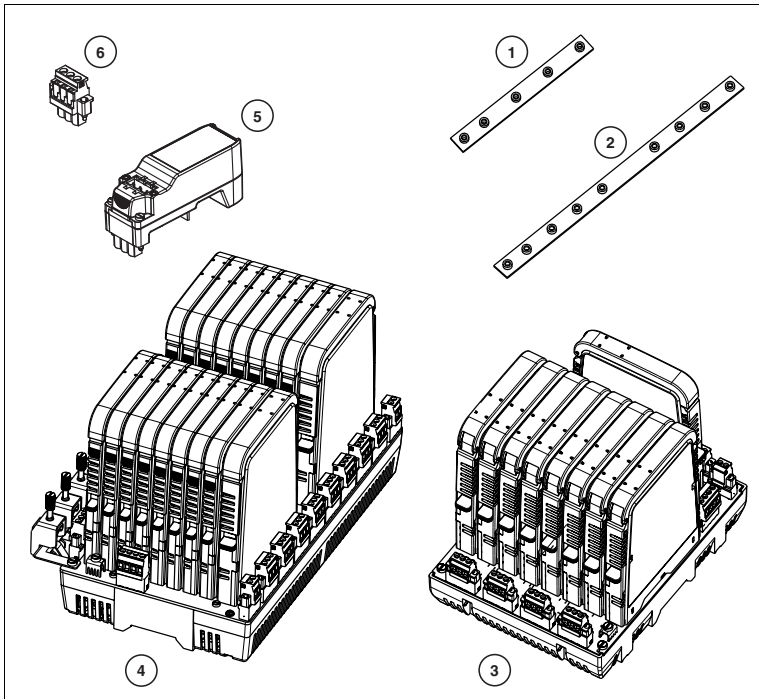





Figure 2.2

- 1 Grounding rail ACC-LBF-EB.4 suitable for MBHD-FB1-4R* Motherboards
- 2 Grounding rail ACC-LBF-EB.8 suitable for MBHC-FB-8R* Motherboards
- 3 Power Hub Motherboard MBHD-FB1-4R*
- 4 Power Hub Motherboard MBHC-FB-8R*
- 5 Surge Protector TPH-LBF-IA1.36.IE*
- 6 Trunk connector

The Surge Protector TPH-LBF-IA1.36.IE* mounts on the trunk connection of the Power Hub Motherboard. Use 1 Surge Protector for each trunk connection. See chapter 3.2.3



2.3 Technical Data

2.3.1 TPH-LBF-IA1.36.DE.*



Fieldbus interface	
Self current consumption	max. 6 mA (for version TPH-LBF-IA1.36.DE.1), max. 0 mA (for version TPH-LBF-IA1.36.DE.0)
Indicators/operating means	
LED ERR	green flashing: status OK , red flashing: maintenance required , (for version TPH-LBF-IA1.36.DE.1)
Electrical specifications	
Rated voltage	36 V
Rated current	600 mA
Continuous voltage	max. 33 V
Reaction time	
Line/Line	max. 1 ns
Line/Earth	max. 100 ns
Series resistance in line	2 Ω +/- 5 %
Ambient conditions	
Ambient temperature	-40 ... 70 °C (-40 ... 158 °F)
Data for application in connection with Ex-areas	
EC-Type Examination Certificate	SIRA 12 ATEX 2128X
Group, category, type of protection, temperature class	 II 1G Ex ia IIC T4
Voltage U_i	24 V
Current I_i	500 mA
Internal capacitance C_i	2 nF
Internal inductance L_i	0.1 μH
Statement of conformity	
Group, category, type of protection, temperature class	 II 3G Ex nAc IIC T4 ,  II 3G Ex ic IIC T4
Voltage U_i	33 V
Current I_i	600 mA
Internal capacitance C_i	2 nF
Internal inductance L_i	0.1 μH

2.3.2

TCP-LBF-IA1.36.IE*

Fieldbus interface	
Self current consumption	max. 6 mA (for version TCP-LBF-IA1.36.IE.1) , max. 0 mA (for version TCP-LBF-IA1.36.IE.0)
Indicators/operating means	
LED ERR	green flashing: status OK , red flashing: maintenance required , (for version TCP-LBF-IA1.36.IE.1)
Electrical specifications	
Rated voltage	36 V
Rated current	600 mA
Continuous voltage	max. 33 V
Reaction time	
Line/Line	max. 1 ns
Line/Earth	max. 100 ns
Screen/Shield-Earth	max. 100 ns
Series resistance in line	2 Ω +/- 5 %
Ambient conditions	
Ambient temperature	-40 ... 70 °C (-40 ... 158 °F)
Data for application in connection with Ex-areas	
EC-Type Examination Certificate	SIRA 12 ATEX 2128X
Group, category, type of protection, temperature class	 II 1G Ex ia IIC T4
Voltage U_i	24 V
Current I_i	500 mA
Internal capacitance C_i	2 nF
Internal inductance L_i	0.1 μH
Statement of conformity	SIRA 12 ATEX 4176X
Group, category, type of protection, temperature class	 II 3G Ex nAc IIC T4 ,  II 3G Ex ic IIC T4
Voltage U_i	33 V
Current I_i	600 mA
Internal capacitance C_i	2 nF
Internal inductance L_i	0.1 μH

2.3.3 SCP-LBF-IA1.36.IE.*

Fieldbus interface	
Self current consumption	max. 6 mA (for version SCP-LBF-IA1.36.IE.1) , max. 0 mA (for version SCP-LBF-IA1.36.IE.0)
Indicators/operating means	
LED ERR	green flashing: status OK , red flashing: maintenance required (for version SCP-LBF-IA1.36.IE.1)
Electrical specifications	
Rated voltage	36 V
Rated current	250 mA
Continuous voltage	max. 33 V
Reaction time	
Line/Line	max. 1 ns
Line/Earth	max. 100 ns
Screen/Shield-Earth	max. 100 ns
Ambient conditions	
Ambient temperature	-40 ... 70 °C (-40 ... 158 °F)
Data for application in connection with Ex-areas	
EC-Type Examination Certificate	SIRA 12 ATEX 2128X
Group, category, type of protection, temperature class	 II 1G Ex ia IIC T4
Voltage U_i	24 V
Current I_i	500 mA
Internal capacitance C_i	2 nF
Internal inductance L_i	0.1 μ H
Statement of conformity	SIRA 12 ATEX 4176X
Group, category, type of protection, temperature class	 II 3G Ex nAc IIC T4 ,  II 3G Ex ic IIC T4
Voltage U_i	33 V
Current I_i	600 mA
Internal capacitance C_i	2 nF
Internal inductance L_i	0.1 μ H

2.4 Dimensional Drawings

2.4.1 TCP-LBF-IA1.36.IE*

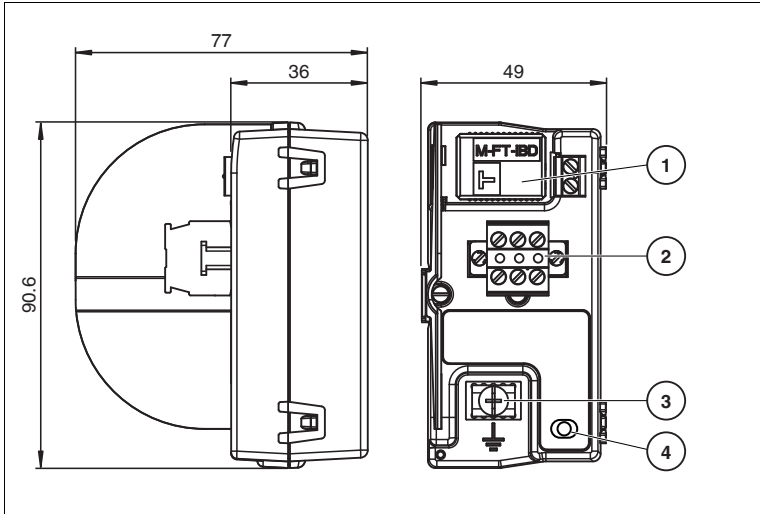

- 1 Terminator M-FT*
- 2 T-connector
- 3 Grounding terminal
- 4 LED, red (only TCP-LBF-IA1.36.IE.1)

2.4.2 Surge Protector SCP-LBF-IA1.36.IE*

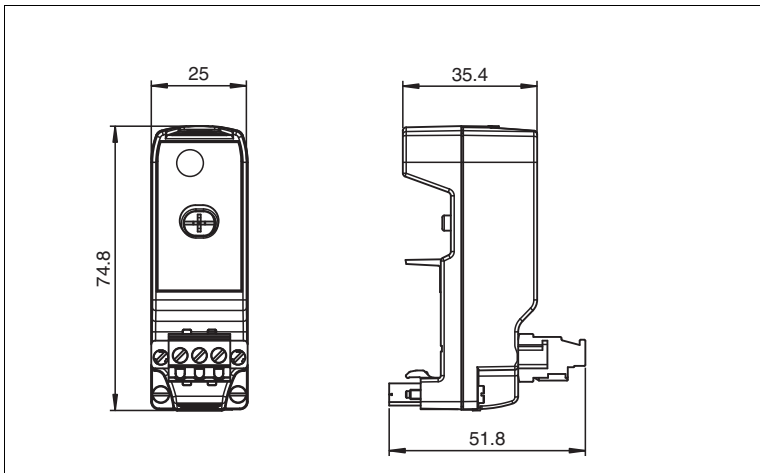

2012-10



2.4.3 Surge Protector TPH-LBF-IA1.36.DE*

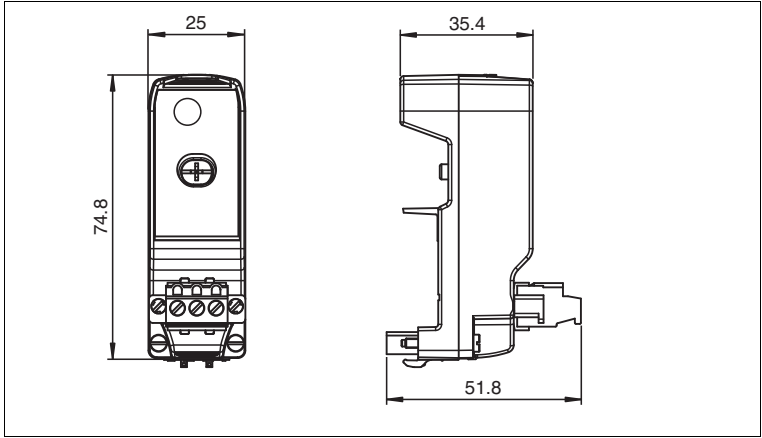

3 Installation

3.1 Installation of Surge Protector

Prior to mounting, installation, and commissioning of the device you should make yourself familiar with the device and carefully read the instruction manual.

Observe the EC-type-examination certificate. It is especially important to maintain any "special conditions for safe use" that may be indicated.

The devices may be installed in a corrosive location acc. to ISA-S71.04-1985, severity level G3.

Pay attention to avoid electrostatic discharges while operating the installed device. Avoid electrostatic charge.

Recognized rules of the technology and setup requirements must be observed during mounting and dismounting. Especially for tasks on electrical systems, special safety requirements must be observed. Special attention must be paid to the following points:

1. Has the device been installed in accordance with the specification?
2. Is the device free of damage?
3. Is IP protection ensured?
4. Is the mounted device mechanically locked?

3.2 Mounting and Dismounting

3.2.1 Surge Protector TCP-LBF-IA1.36.IE* for Trunk Connection

The Surge Protector TCP-LBF-IA1.36.IE* in combination with the fieldbus couplers R2-SP-* and R3-SP-*.



Warning!
WARNING!

The TCP-LBF-IA1.36.IE.1 and the TCP-LBF-IA1.36.DE.1 Surge Protector must not be used in combination with the DART Segment Protector R3-SP-*!

The Surge Protectors are delivered without T-connector and Terminator M-FT*. Both have to be taken from the fieldbus coupler the Surge Protector will be used with.

Mounting the Surge Protector

Mounting

1. Remove the T-connector and Terminator from the trunk connection (1).

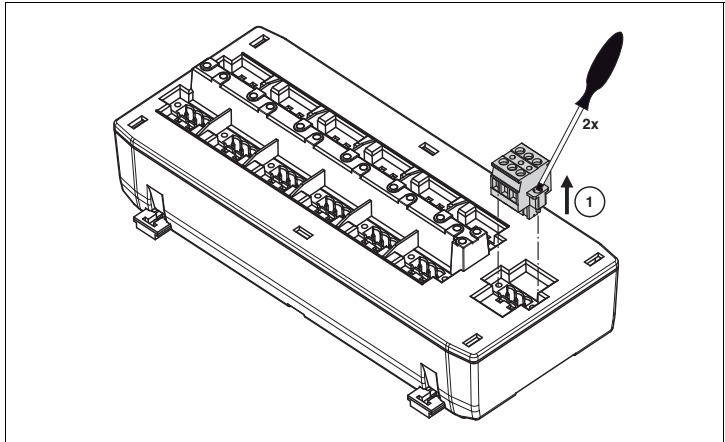

2. Plug the Surge Protector in the trunk connection and fix the Surge Protector with the 2 screws on the Segment Protector (2).

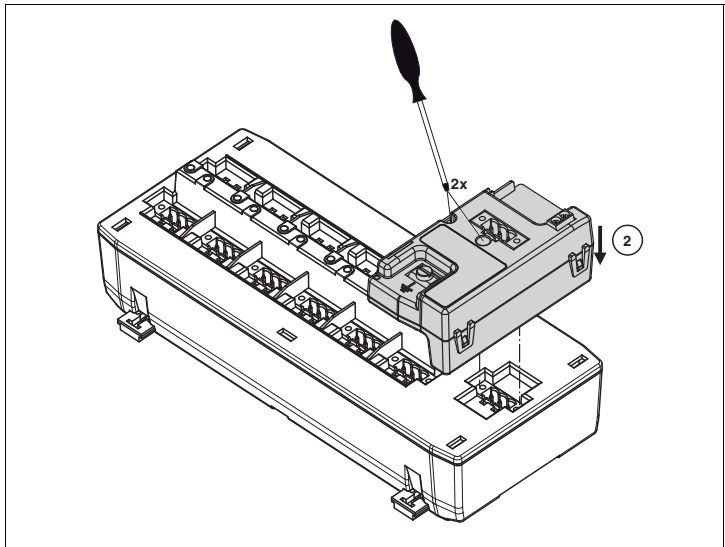

3. Plug the T-connector in the trunk connection of the Surge Protector and fix the T-connector with the 2 screws (3).
4. Screw the Terminator into the corresponding terminal block of the Surge Protector (4).

5. Connect the grounding rail to the grounding terminal of the housing (5).

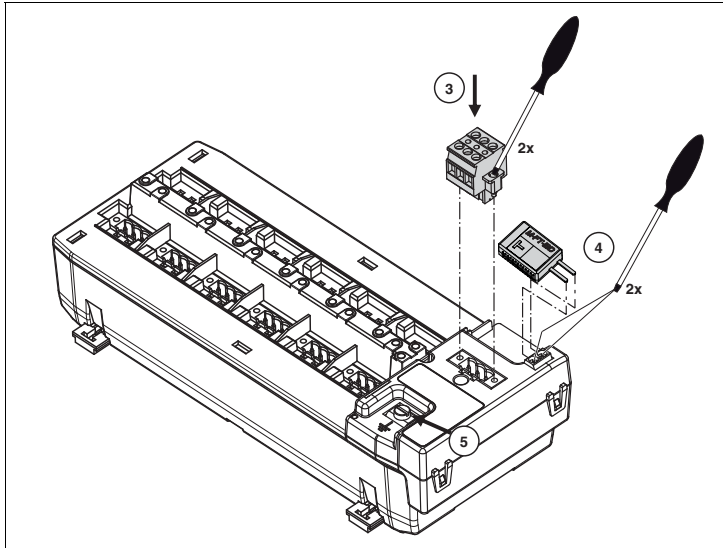

The grounding terminal should be connected to an equal potential bonding system using a minimum cross core section of 4 mm^2 .

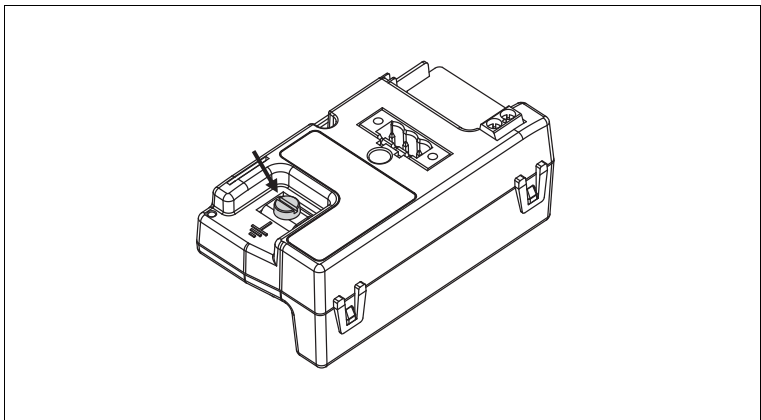

The shield connection of the trunk is internally indirectly connected to the grounding terminal through a gas discharge tube.



Connect the ground cable to a cable lug

1. Position the cable lug (3) over the grounding terminal so that the cable points downwards.
2. Screw the cable lug (3) to the grounding terminal (4) using 2 toothed lock washers (2).
3. Tighten the screw with a torque of 1.5 Nm (1).

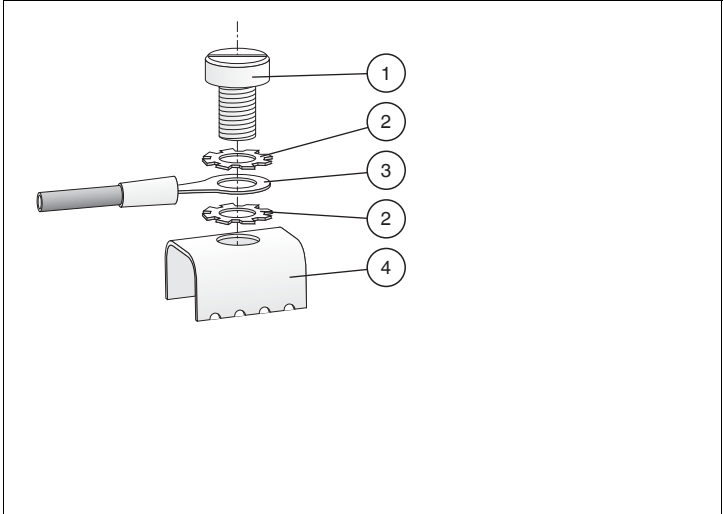

Mounting the Separation Wall

When using R2-SP* Segment Protectors in combination with fieldbus power supplies to generate Ex ic rated spur outputs, the delivered separation wall ACC-LBF-SW has to be installed on the Segment Protector. This is to guarantee the clearance distance of 50 mm between the trunk connector and the spur connector.



Mounting

1. Insert the lugs of the separation wall into the openings of the Surge Protector (1).
2. Slide the separation wall backwards until it snaps into place (2).

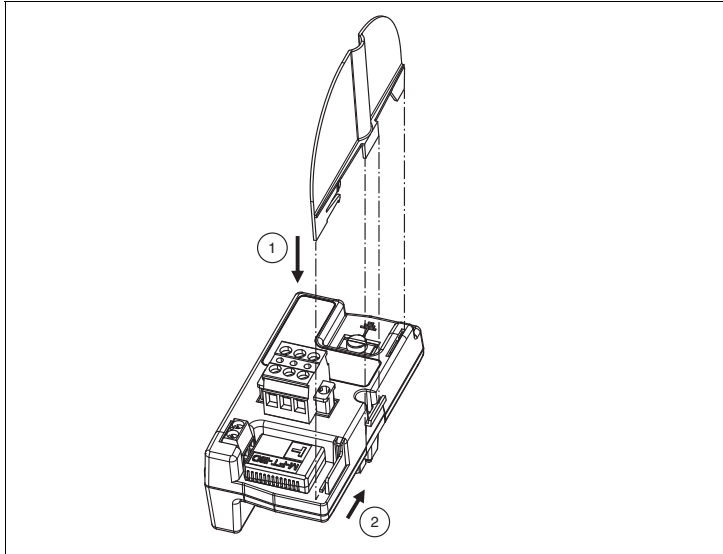

3.2.2 Surge Protector SCP-LBF-IA1.36.IE* for Spur Connection

SCP-LBF-IA1.36.IE* Surge Protectors in combination with the fieldbus couplers R2-SP*, R3-SP*, R4D0-FB*.

The Surge Protector comes without a spur connector. The spur connector has to be taken from the fieldbus coupler the Surge Protector will be used with.

Mounting the Surge Protector for Spur Connections

Mounting

1. Remove the spur connector from the spur connection (1).

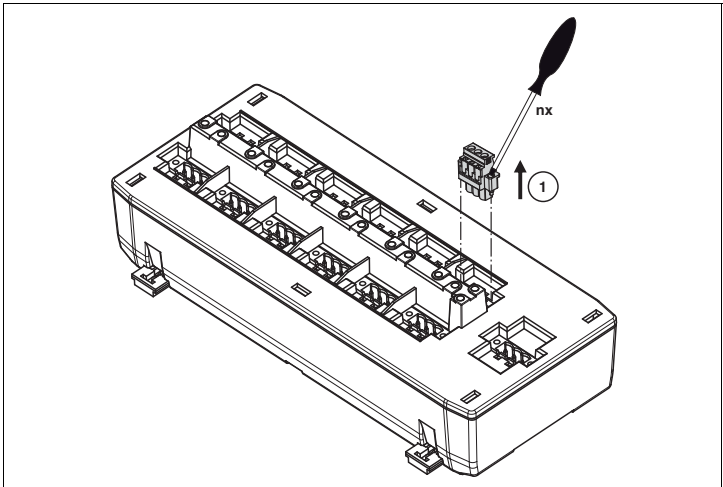

2. Plug the Surge Protector into the spur connection and fix the Surge Protector with 2 screws (2).

3. Plug the spur connector into the Surge Protector and fix the spur connector with 2 screws (3).

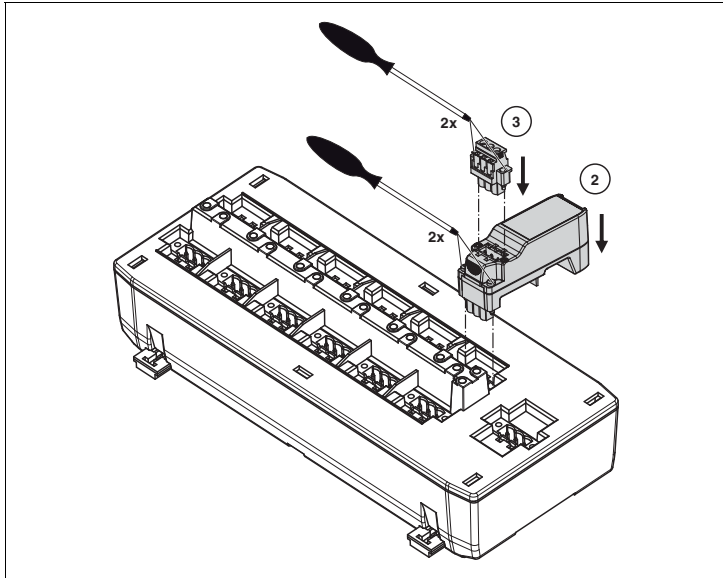

4. Mount the grounding rail at the bottom of the Surge Protector (4). Note that you can connect multiple Surge Protectors via one single grounding rail.

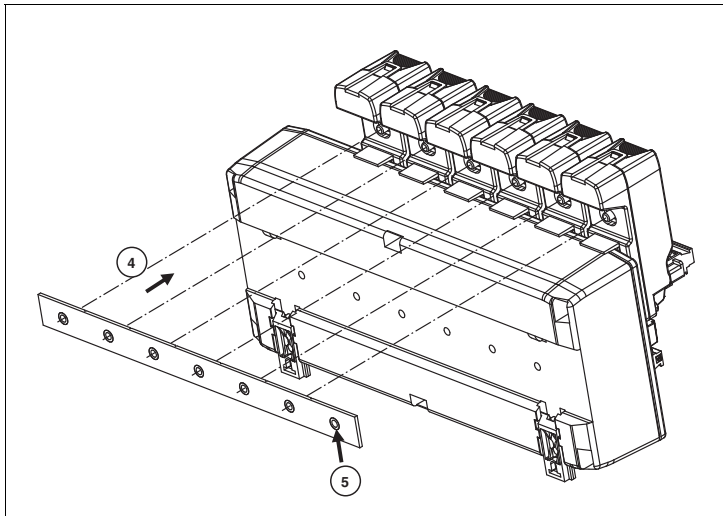

5. Connect the grounding rail to the grounding terminal of the housing (5).

Grounding rail ACC-LBF-EB.6

For attaching Surge Protectors to the spur connections of Pepperl+Fuchs fieldbus couplers R2-SP*, R3-SP*, and F4D0-FB-IA*, the optional grounding rail ACC-LBF-EB.6 is used to provide a common earth point and mechanical support for up to 6 SCP-LBF-1.36* modules. For Surge Protectors that are placed on both sides of the fieldbus couplers, 2 grounding rails ACC-LBF-EB.6 are required. If fieldbus couplers are used with less than 6 spurs on one side, the grounding rail can easily be cut or snapped to length.

The grounding rail provides a screw clamp to be connected to an equal potential bonding system using a minimum cross core section of 4 mm².

Connect the Ground Cable at the Grounding Rail

1. Position the cable lug (3) over the grounding terminal of the grounding rail (4), so that the cable points downwards.
2. Screw the cable lug (3) to the grounding terminal (4) using 2 toothed lock washers (2).
3. Tighten the screw with a torque of 1.5 Nm (1).

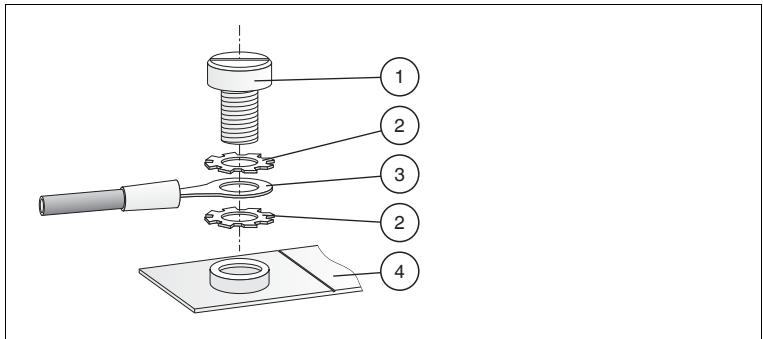

Internally, the shield connection of the trunk is directly connected to the grounding terminal through a gas discharge tube.

Connect the Grounding Rail to the Grounding Terminal of the Housing

1. Position the cable lug (3) over the grounding terminal (4) so that the cable points downwards.
2. Screw the cable lug to the grounding terminal (4) using 2 toothed lock washers (2).

3. Tighten the screw with a torque of 1.5 Nm (1).

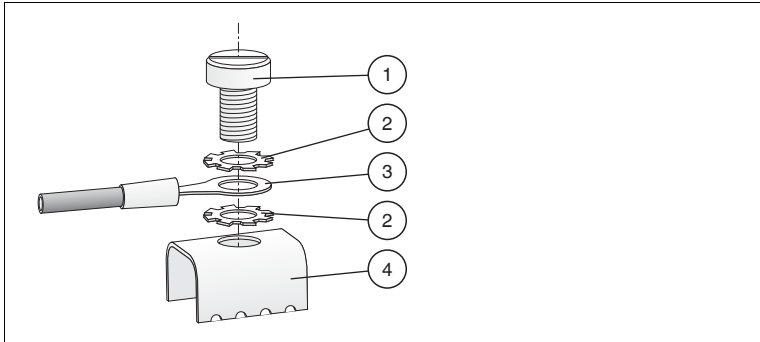

3.2.3 Surge Protector TPH-LBF-IA1.36.DE* Trunk Connection for Power Hub
TPH-LBF-IA1.36.DE* Surge Protectors in combination with Power Hub
Motherboards.



Warning!
WARNING!

The TPH-LBF-IA1.36.DE.1 Surge Protector must not be used in combination with the DART Power Hub Backplane MBHD-FB-D*!

Mounting the Surge Protector



Mounting

1. Remove the trunk connector from the trunk connection (1).

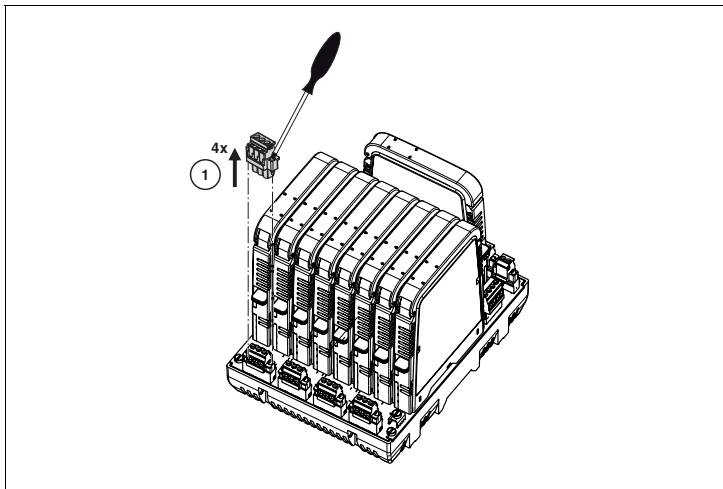

2. Plug the Surge Protector into the trunk connection and fix the Surge Protector with 2 screws (2).
3. Plug the trunk connector into the Surge Protector and fix the trunk connector with 2 screws (3).

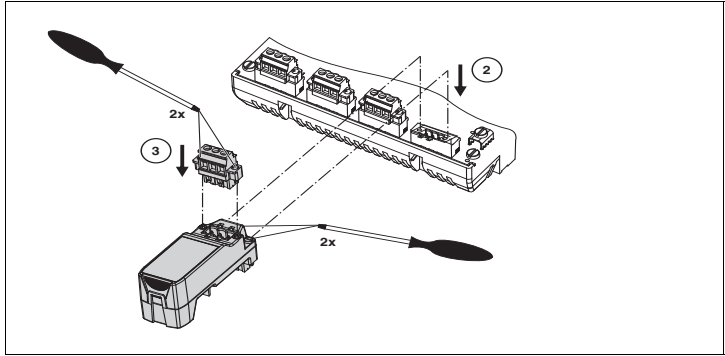

4. Mount the grounding rail at the bottom of the Surge Protector (4). Note that you can connect multiple Surge Protectors via one single grounding rail.
5. Connect the grounding rail to the grounding terminal of the housing (5).

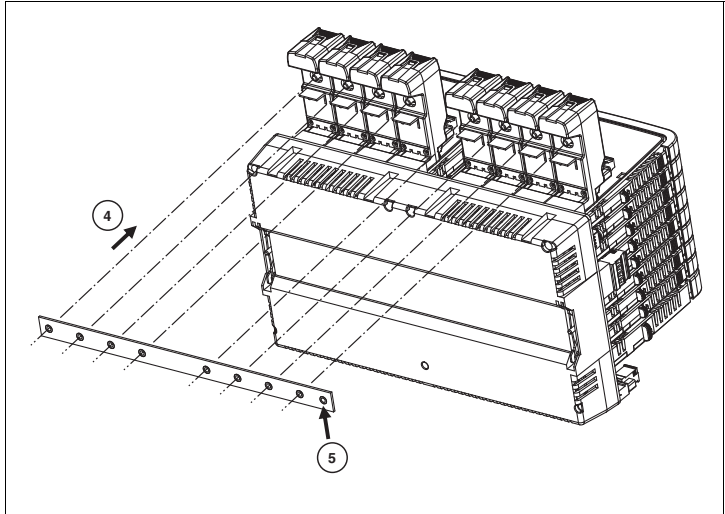

Grounding Rail ACC-LBF-EB.8

For attaching Surge Protectors to the trunk connections of the Pepperl+Fuchs Power Hub MBHD-FB1*, the optional grounding rail ACC-LBF-EB.8 is used to provide a common earth point and mechanical support for the TPH-LBF-1.36* modules.

The grounding rail provides a screw clamp to be connected to an equal potential bonding system using a minimum cross core section of 4 mm².

Internally, the shield connection of the trunk is directly connected to the grounding terminal through a gas discharge tube.

Connect the Ground Cable at the Grounding Rail

1. Position the cable lug (3) over the grounding terminal (4) of the grounding rail (1), so that the cable points downwards.
2. Screw the cable lug (3) to the grounding terminal (4) using 2 toothed lock washers (2).
3. Tighten the screw with a torque of 1.5 Nm (1).

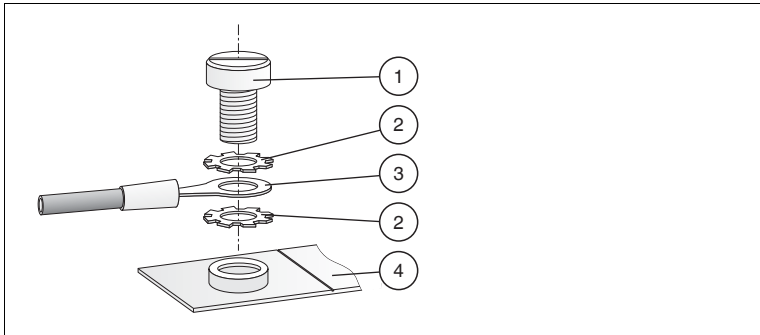

Internally, the shield connection of the trunk is directly connected to the grounding terminal through a gas discharge tube.

Connect the Grounding Rail to the Grounding Terminal of the Housing

1. Position the cable lug (3) over the grounding terminal (4) so that the cable points downwards.
2. Screw the cable lug to the grounding terminal (4) using 2 toothed lock washers (2).

3. Tighten the screw with a torque of 1.5 Nm (1).

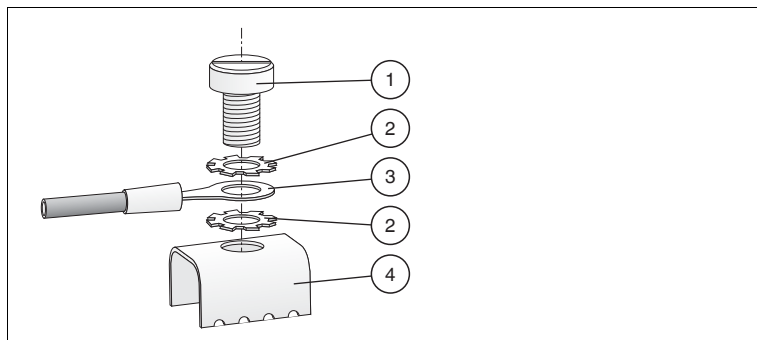

4

Appendix

4.1

Ordering Information

Designation	Description
TPH-LBF-IA1.36.DE.0	Surge Protector for Power Hub trunk connection, shield directly grounded.
TPH-LBF-IA1.36.DE.1	Surge Protector for Power Hub trunk connection, diagnostics included, shield directly grounded.
ACC-LBF-SW.3	Separation wall for TPH-LBF-IA1.36* in Ex ic application. Package of 3 pieces.
TCP-LBF-IA1.36.IE.1	Surge Protector for fieldbus coupler trunk connection, diagnostics included, shield grounded through GDT.
SCP-LBF-IA1.36.IE.0	Surge Protector for fieldbus coupler spur connection, shield grounded through GDT.
SCP-LBF-IA1.36.IE.1	Surge Protector for fieldbus coupler spur connection, diagnostics included, shield grounded through GDT.
ACC-LBF-EB.4	Grounding rail to provide a common earth point and mechanical support for up to 4 TPH-LBF-1.36* modules on MBHD-FB1-4R* Power Hubs.
ACC-LBF-EB.6	Grounding rail to provide a common earth point and mechanical support for up to 6 SCP-LBF-1.36* modules.
ACC-LBF-EB.8	Grounding rail to provide a common earth point and mechanical support for up to 8 TPH-LBF-1.36* modules on MBHC-FB-8R* Power Hubs.

PROCESS AUTOMATION – PROTECTING YOUR PROCESS



Worldwide Headquarters

Pepperl+Fuchs GmbH
68307 Mannheim · Germany
Tel. +49 621 776-0
E-mail: info@de.pepperl-fuchs.com

For the Pepperl+Fuchs representative
closest to you check www.pepperl-fuchs.com/contact

www.pepperl-fuchs.com

Subject to modifications
Copyright PEPPERL+FUCHS • Printed in Germany

 **PEPPERL+FUCHS**
PROTECTING YOUR PROCESS

TDOCT-2761_ENG
04/2013