

MANUAL

Basic Diagnostic Module

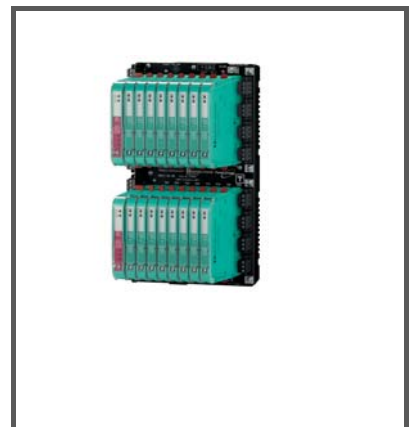

With regard to the supply of products, the current issue of the following document is applicable: The General Terms of Delivery for Products and Services of the Electrical Industry, published by the Central Association of the Electrical Industry (Zentralverband Elektrotechnik und Elektroindustrie (ZVEI) e.V.) in its most recent version as well as the supplementary clause: "Expanded reservation of proprietorship"

| | | |
|----------|--|-----------|
| 1 | Safety | 4 |
| 1.1 | Validity..... | 4 |
| 1.2 | Symbols used..... | 4 |
| 1.3 | System Operator and Personnel | 4 |
| 1.4 | Pertinent Laws, Standards, Directives, and further Documentation..... | 4 |
| 1.5 | Delivery, Transport and Storage | 5 |
| 1.6 | Marking | 5 |
| 1.7 | Intended Use | 5 |
| 1.8 | Mounting and Installation..... | 5 |
| 1.8.1 | Mounting Instructions..... | 5 |
| 1.8.2 | Zone 2 and Div. 2 | 6 |
| 1.8.3 | Ex ic..... | 6 |
| 1.9 | Housing..... | 6 |
| 1.10 | Repair and Maintenance..... | 6 |
| 1.11 | Disposal | 6 |
| 2 | Specification | 7 |
| 2.1 | System Components | 7 |
| 2.1.1 | Basic Diagnostic Module | 7 |
| 2.2 | Component Overview | 8 |
| 2.3 | Technical Data | 9 |
| 2.4 | Dimensional Drawings..... | 10 |
| 3 | Installation and Commissioning | 11 |
| 3.1 | Mounting..... | 11 |
| 4 | Fieldbus Power Hub Basic Diagnostics | 12 |
| 5 | Appendix | 13 |
| 5.1 | Ordering Information | 13 |
| 5.2 | Electromagnetic Compatibility Verification in Accordance with EC Council Legislation Directive 2004/108/EC | 13 |

1 Safety

1.1 Validity

Specific processes and instructions in this document require special precautions to guarantee the safety of the operating personnel.

1.2 Symbols used

This document contains information that you must read for your own personal safety and to avoid property damage. Depending on the hazard category, the warning signs are displayed in descending order as follows:

Safety-relevant symbols



Danger!

This symbol indicates an imminent danger.

Non-observance will result in personal injury or death.



Warning!

This symbol indicates a possible fault or danger.

Non-observance may cause personal injury or serious property damage.



Caution!

This symbol indicates a possible fault.

Non-observance could interrupt devices and any connected facilities or systems, or result in their complete failure.

Informative symbols



Note!

This symbol brings important information to your attention.



Action

This symbol indicates a paragraph with instructions.

1.3 System Operator and Personnel

Responsibility for planning, assembly, commissioning, operation, maintenance, and dismantling lies with the system operator.

Mounting, installation, commissioning, operation, maintenance and disassembly of any devices may only be carried out by trained, qualified personnel. The instruction manual must be read and understood.

1.4 Pertinent Laws, Standards, Directives, and further Documentation

Laws, standards, or directives applicable to the intended use must be observed. In relation to hazardous areas, Directive 1999/92/EC must be observed.

The corresponding data sheets, declarations of conformity, EC-type-examination certificates, certificates and Control Drawings if applicable (see data sheet) are an integral part of this document. You can find this information under www.pepperl-fuchs.com.

Due to constant revisions, documentation is subject to permanent change. Please refer only to the most up-to-date version, which can be found under www.pepperl-fuchs.com.

1.5 Delivery, Transport and Storage

Check the packaging and contents for damage.

Check if you have received every item and if the items received are the ones you ordered.

Keep the original packaging. Always store and transport the device in the original packaging.

Always store the device in a clean and dry environment. The permitted storage temperature (see data sheet) must be considered.

1.6 Marking

Basic Diagnostic Module

HD2-DM-B

Pepperl+Fuchs GmbH

Fieldbus Power Hub
Fieldbus Diagnostic Module Basic Version

TÜV 04 ATEX 2500 X

 II 3G EEx nA C IIC T4

IECEX TUN 13.0038X

Ex nA nC IIC T4 Gc

1.7 Intended Use

The FieldConnex[®] Basic Diagnostic Module HD2-DM-B is a plug-in module for the FieldConnex[®] Power Hub. The diagnostic module is used to provide basic system diagnostics. It checks for proper operation of bulk power supplies and monitors the connected trunks for overload or short-circuit conditions. All power hub modules are checked for proper function. On redundant power modules it indicates mismatching pairs.

The module indicates a fault condition via voltage-free contact and provides monitoring "plug-and-play" without additional engineering. LED signals indicate a fault for easy detection.

The module can be installed as component of the power hub in Zone 2 or Class I, Division 2 hazardous areas. Types of protection are Ex nA (non-arcing) for Zone 2, gas groups IIC, IIB, IIA, and non-incendive for use in Class I, Division 2, gas groups A, B, C, and D.

The devices are only approved for appropriate and intended use. Ignoring these instructions will void any warranty and absolve the manufacturer from any liability.

The device must only be operated in the ambient temperature range and at the relative humidity (non-condensing) specified.

1.8 Mounting and Installation

Prior to mounting, installation, and commissioning of the device you should make yourself familiar with the device and carefully read the instruction manual.

The devices may be installed in a corrosive location acc. to ISA-S71.04-1985, severity level G3.

1.8.1 Mounting Instructions

The modules are intended for mounting on an appropriate fieldbus power hub motherboard.

The power hub motherboard features a special connection slot for HD2-DM-* diagnostic modules labeled "Diagnostic Module only". Do not try to plug any other modules into this connection slot. Other modules may be damaged.

1.8.2 Zone 2 and Div. 2

Connection or disconnection of energized non-intrinsically safe circuits is only permitted in the absence of a hazardous atmosphere.

The devices must be installed and operated only in surrounding enclosures that

- comply with the requirements for surrounding enclosures according to IEC/EN 60079-0
- are rated with the degree of protection IP54 according to IEC/EN 60529

Prevent any electrostatic charge that could result in electrostatic discharge while installing or operating the device.

In Zone 2, only such devices are allowed to be connected to circuits that are suitable for the operation in explosion hazardous areas of Zone 2 and for the conditions available at the place of operation (declaration of conformity or certificate of a testing department).

1.8.3 Ex ic

The devices must be installed and operated only in an environment that ensures a pollution degree 2 (or better) according to IEC/EN 60664-1.

1.9 Housing

If additional housings are needed for installation in hazardous areas, the following points must be considered / evaluated:

To ensure the IP degree of protection:

- all seals must be undamaged and correctly fitted
- all screws of the housing and its cover must be tightened with the appropriate torque
- only cable of the appropriate size must be used in the cable glands
- all cable glands must be tightened with the appropriate torque
- all unused cable glands must be sealed or plugged with corresponding plugs

1.10 Repair and Maintenance

The devices must not be repaired, changed or manipulated. If there is a defect, the product must always be replaced with an original device.

1.11 Disposal

Disposing of devices, packaging material, and possibly contained batteries must be in compliance with the applicable laws and guidelines of the respective country.

2 Specification

2.1 System Components

2.1.1 Basic Diagnostic Module

The basic diagnostic module provides basic system diagnostics. It monitors the input voltage of the bulk power supply and each segment for overload and short circuit conditions. Each power supply module is checked for proper function. Power modules operating in redundant configuration are checked for compatibility. Status and faults are indicated by LEDs and can be transmitted via dry contact.

Self-supervision functions consist of circuitry located in the motherboard, the power modules and an optional diagnostics module. Basic diagnostics monitor the power hub system for the following conditions:

- Availability of bulk power supplies
- Output voltage and overload or short circuit conditions per segment
- Module failure

In redundant configurations, a system integrity check is performed annunciating mismatching types of power modules and the availability of only 1 power module.

Visual alarm notification, which meets the requirements of NAMUR NE44, is provided by the power and diagnostic modules. Green LEDs and a normally closed, potential-free contact indicate normal system operation. If an abnormal system condition is detected, a red LED starts flashing. Simultaneously, the relay contact opens.

The following figure illustrates the locations of the LEDs on the modules.

For more information on the conditions, see table "Basic Diagnostic Information" on page 12.

2.2 Component Overview

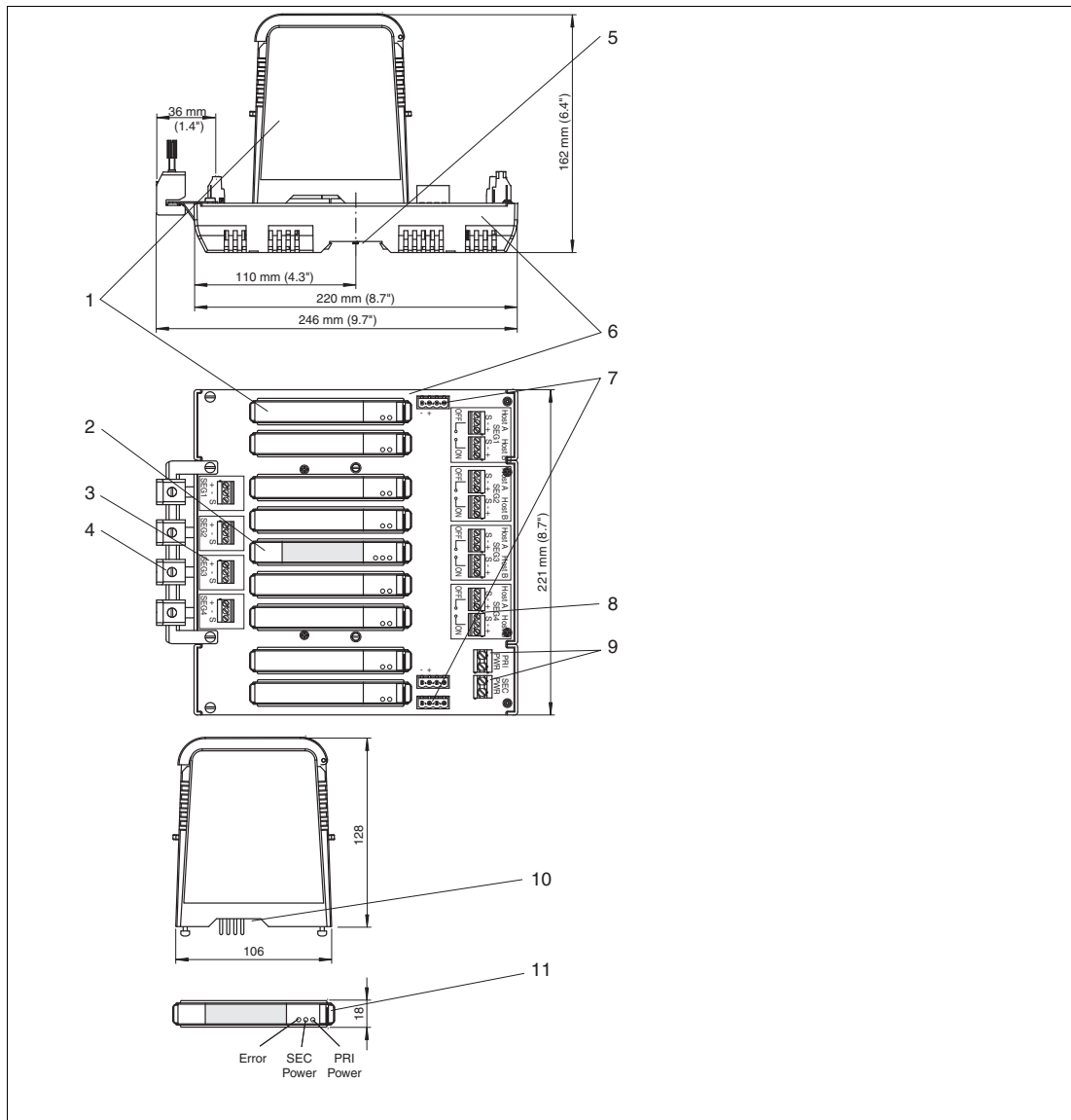

- 1 Power supply modules, see separate manuals or data sheets
- 2 Diagnostic module
- 3 Connections for fieldbus trunk, terminator switch
- 4 Screening/earthing kit for trunk cables shield, optional accessory
- 5 Mounting slot for DIN mounting rail
- 6 Motherboard, see separate manuals or data sheets
- 7 Connections for alarm, voltage-free contact and diagnostics bus
- 8 Connections for redundant host
- 9 Connections for redundant bulk power supply
- 10 Plug connections to motherboard
- 11 Status and fault indication LEDs

2.3 Technical Data

Basic Diagnostic Module Type HD2-DM-B

| Supply | |
|-----------------------------------|--|
| Rated voltage | 19.2 ... 35 V |
| Rated current | 20 mA |
| Power loss | Max. 0.5 W |
| Indicators/operating means | |
| LED PRI PWR | green: on, primary bulk power supply connected |
| LED SEC PWR | green: on, secondary bulk power supply connected |
| LED ERR | red: 2 Hz flashing, power supply fault (short-circuit, undervoltage), redundancy fault |
| Ambient conditions | |
| Ambient temperature | -40 ... 70 °C (-40 ... 158 °F) |
| Storage temperature | -40 ... 85 °C (-40 ... 185 °F) |
| Relative humidity | < 95 % non-condensing |
| Shock resistance | 15 g 11 ms |
| Vibration resistance | 1 g , 10 ... 150 Hz |
| Pollution Degree | max. 2, according to IEC 60664 |
| Corrosion resistance | acc. to ISA-S71.04-1985, severity level G3 |
| Mechanical specifications | |
| Connection type | motherboard specific |
| Core cross-section | motherboard specific |
| Degree of protection | IP20 |
| Standard conformity | |
| Electromagnetic compatibility | NE 21:2011 |
| Degree of protection | IEC 60529 |
| Shock resistance | EN 60068-2-27 |
| Vibration resistance | EN 60068-2-6 |

2.4 Dimensional Drawings

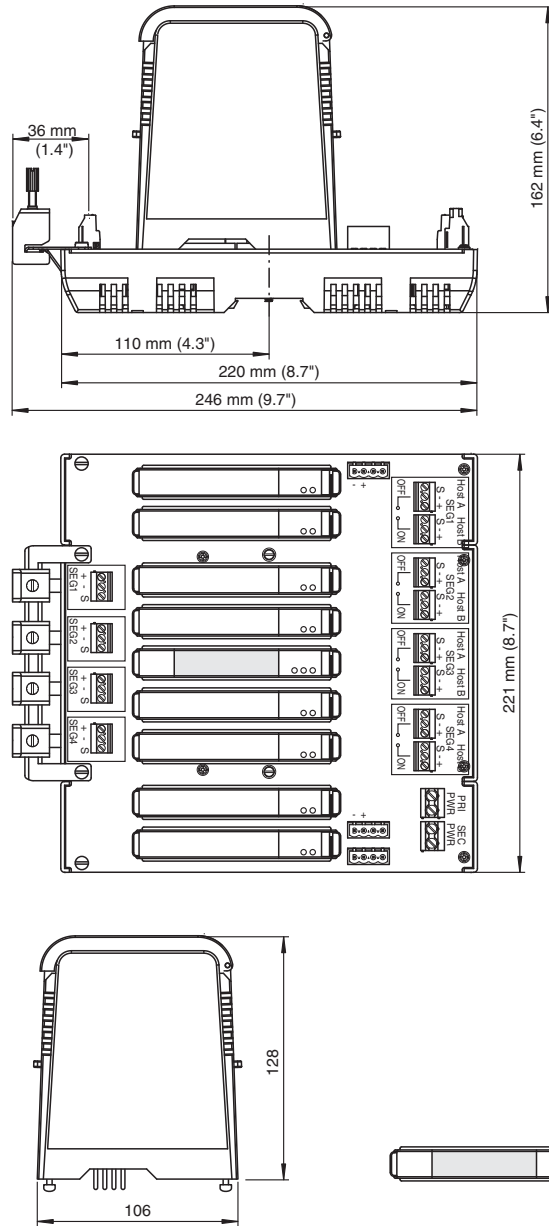

All dimensions in millimeters (inches) and without tolerance indication.

3 Installation and Commissioning

3.1 Mounting



Caution!

Hardware Damage

The Power Hub motherboard includes a dedicated connection slot for the HD2-DM* diagnostic modules labeled "Diagnostic Module only".

Do not try to plug other modules into this connection slot. Other modules may be damaged.



Mounting of HD2-DM* Modules on the Motherboard

To install a new module on the motherboard, proceed as follows:

1. Carefully center the polarisation holes and mate the two connectors, then gently press down the module.
2. Push down the red Quick Lok Bars on each side of the module to fix it to the panel.

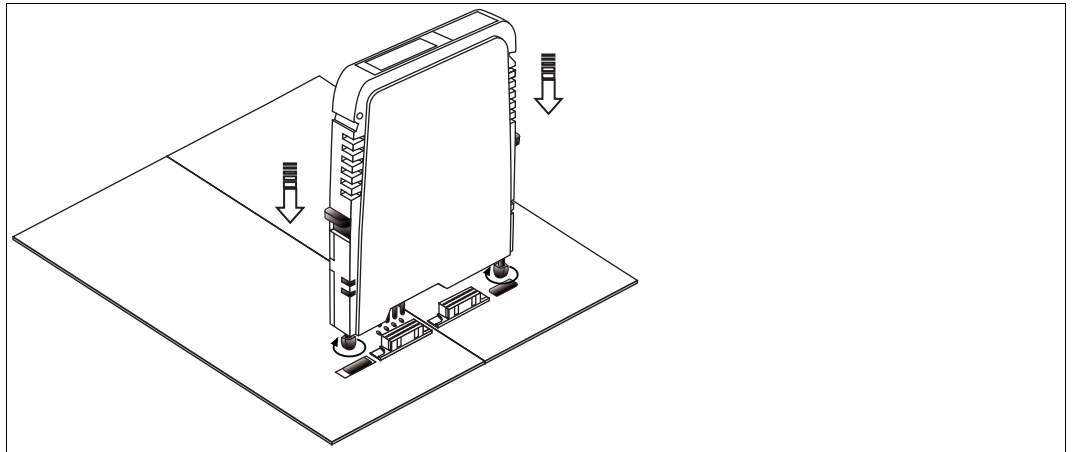

Figure 3.1 Mounting HD2-DM*

↳ The new module has been installed.

4 Fieldbus Power Hub Basic Diagnostics

The FieldConnex® Power Hub system provides integrated self-supervision functionality located in the power and the motherboards. Additionally, a basic diagnostic module is available to monitor the bulk power supply status and compatibility of the mounted power modules in redundant systems. The following conditions are monitored:

- Availability of the bulk power supply
- Output voltage per segment
- Overload or short circuit per segment
- Power module failure

The status of the power hub is shown by LED indication and by a normally closed, voltage-free contact. Normal operating conditions are shown by green LEDs, the voltage-free contact is closed. See table below for detail diagnostic information.

Basic Diagnostic Information

| Fault | Relay Contact | Diagnostic Module | Power Module |
|--|---------------|---|--|
| A: Supply under/over voltage detection | | | |
| > 18.5 V DC +/- 4 % < 35.8 V DC +/- 4 % | | <ul style="list-style-type: none"> ● PRI PWR ● SEC PWR ○ ERR | <ul style="list-style-type: none"> ● PWR ○ ERR |
| < 17.5 V DC +/- 4 % > 36.8 V DC +/- 4 %* | | <ul style="list-style-type: none"> ○ PRI PWR ○ SEC PWR ● ERR | <ul style="list-style-type: none"> ○ PWR ● ERR |
| B: Power module compatibility redundant system only | | | |
| All modules have intact redundancy partner | | <ul style="list-style-type: none"> ● PRI PWR ● SEC PWR ○ ERR | <ul style="list-style-type: none"> ● PWR ○ ERR |
| Only 1 power module is fitted to a segment | | <ul style="list-style-type: none"> ● PRI PWR ● SEC PWR ● ERR | <ul style="list-style-type: none"> ● PWR ○ ERR |
| C: Power module or load status | | | |
| Power module failure | | <ul style="list-style-type: none"> ● PRI PWR ● SEC PWR ● ERR | <ul style="list-style-type: none"> ○ PWR ● ERR |
| Output overload or trunk short circuit | | <ul style="list-style-type: none"> ● PRI PWR ● SEC PWR ● ERR | <ul style="list-style-type: none"> ○ PWR ● ERR |
| All power modules fixed and healthy | | <ul style="list-style-type: none"> ● PRI PWR ● SEC PWR ○ ERR | <ul style="list-style-type: none"> ● PWR ○ ERR |

5 Appendix

5.1 Ordering Information

| Designation | Description |
|-------------|--|
| HD2-DM-B | Basic diagnostic module with LED indication and common relay fault output. |

| Accessories | |
|-------------|---|
| ACC-MB-HDC | Diagnostic link cable Coupling the diagnostic bus between 2 motherboards, length 6 cm. |

5.2 Electromagnetic Compatibility Verification in Accordance with EC Council Legislation Directive 2004/108/EC

Compatibility in Accordance with EN 61326-1 and NAMUR NE 21 Recommendation

The electromagnetic compatibility – EMC – requirements applicable for electrical equipment for measurement, control and laboratory use in general are anchored in the European Standard EN 61326. 3 different performance criteria are distinguished in this standard:

A category **A** device operates as intended during the test. This device can withstand the immunity tests without any noticeable performance degradations within the specification limits of the manufacturer.

A category **B** device operates as intended after the test. The device shows temporary degradation or loss of function of performance during the test but self-recovers from that state when the exposures are ceased.

A category **C** device has loss of function, may need manual restoration. During the test a temporary loss of function is allowed as long as an operator can restore the device back to operation.

The requirements of the association for standard and control and regulations of the German chemical industries, defined in the NE 21 recommendation, are partly higher compared to the test levels and failure criteria defined in EN 61326-1. For the product qualification, failure criteria and test levels have been selected, always representing the worst case conditions.

EN 61000-4, as a generic standard, defines the test setups for the specific required test for EN 61326-1 and NE 21.

See declaration of conformity for standards and editions applied.

Conducted EMC Tests

Immunity

| Standard | Type | Test Level | Category |
|--------------|---|------------|----------|
| EN 61000-4-2 | Electrostatic discharge, direct contact | 6 kV | A |
| | Electrostatic discharge, indirect, air | 8 kV | A |
| EN 61000-4-3 | Electromagnetic field radiated, radio frequency | 10 V/m | A |
| EN 61000-4-4 | Fast transients burst on signal lines | 1 kV | A |
| | Fast transients burst on power lines | 2 kV | A |
| EN 61000-4-5 | Slow transient surge on signal lines | 1 kV | B |
| | Slow transient surge on shielded lines | 2 kV | B |

| Standard | Type | Test Level | Category |
|--------------|-------------------------------------|------------|----------|
| EN 61000-4-6 | Conducted immunity, radio frequency | 10 V | A |
| EN 55011 | RF conducted emission | Class A | – |
| | RF radiated emission | Class A | – |

PROCESS AUTOMATION – PROTECTING YOUR PROCESS



Worldwide Headquarters

Pepperl+Fuchs GmbH
68307 Mannheim · Germany
Tel. +49 621 776-0
E-mail: info@de.pepperl-fuchs.com

For the Pepperl+Fuchs representative
closest to you check www.pepperl-fuchs.com/contact

www.pepperl-fuchs.com

Subject to modifications
Copyright PEPPERL+FUCHS • Printed in Germany

 **PEPPERL+FUCHS**
PROTECTING YOUR PROCESS

/ TDOCT-3808_ENG
08/2014