

AVEVA Mobile Operator Solutions



Mobile Operator and eSENTINEL combining an effective operations management system with improved operator's safety.

At a Glance

Ecom Mobile Devices Empowering Field Workers

to be part of reliability solutions that drive collective behavior and create a culture of asset ownership between operations and maintenance.



The Application

AVEVA Mobile Operator sustains operational process improvements and is a key component of an effective operations management system. Helping ensure that best operating and regulatory procedures are followed at all times.

The Goal

To empower field workers to be part of reliability solutions that drive collective behavior and create a culture of asset ownership between operations and maintenance.

The Solution

AVEVA's Mobile Operator brings the field operator into the automation loop by utilizing a combination of workforce management software, mobile handheld computers, monitoring devices and Radio Frequency Identification (RFID) equipment tags or bar codes. This mobile framework results in a significantly improved support system for managing plant assets with fewer data capture errors.

The AVEVA Mobile Operator App can run on ecom's intrinsically safe tablets and smartphones.

The Pepperl+Fuchs brand ecom has also developed the eSENTINEL app, an easy-to-use tool for improving employee safety. It's the ideal tool for lone workers or tasks with higher risk.

As a perfect supplement to AVEVA's extensive capabilities, Pepperl+Fuchs' eSENTINEL application provides a simple way to reach help in emergency situations via dedicated alert key on the Smart-Ex 02 for hazardous location environments. The app activates the alert when a predefined timer reaches zero or when the phone is inclined below a certain angle.

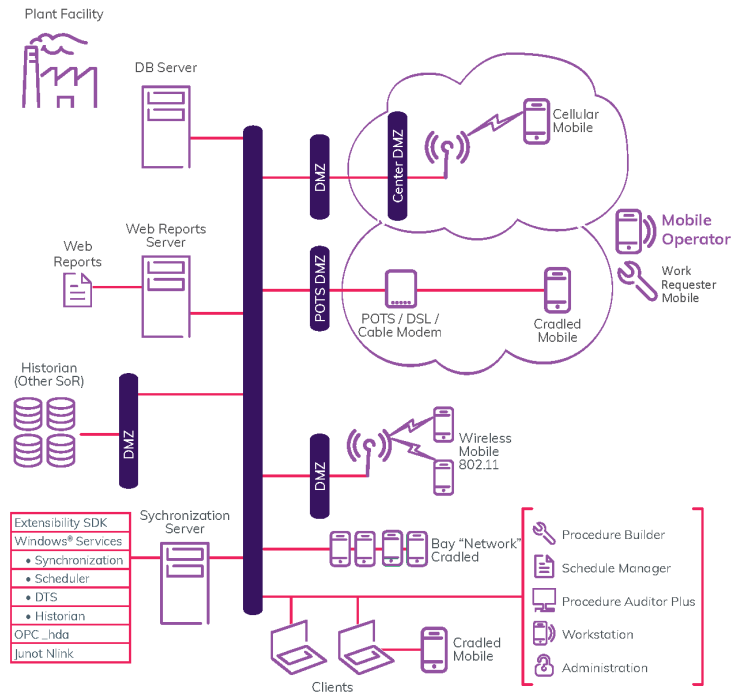

The Benefits

Nowhere is the power of the digital transformation more evident than in the mobility sector. By connecting the mobile work force with real-time system information and empowering subject matter expert's global support via the use of remote access, AVEVA and Pepperl+Fuchs act as the building blocks for Industry 4.0.

Equipment condition data such as vibration or temperature can be easily collected by field operators using a mobile solution as they do their regular operating rounds. Stranded or non-instrumented plant assets can now be efficiently monitored.

The asset-centric approach allows data collected by any operator or plant worker to be aggregated together for a common asset history. This means a more complete and comprehensive view of asset performance and health.

Technical Features

- Initiates SMS or phone calls
- Starts as system service after reboot
- Pre-configurable via XML file (Before installing the APK: Download the XML file with its corresponding settings to the "Downloads" folder on your device
- Password protection to avoid accidental changes by operators



Smart-Ex 02 (DZ1)
Smartphone for Class I, Div. 1 & Zone 1/21



Smart-Ex 02 (DZ2)
Smartphone for Class I, Div. 2 & Zone 2/22



Ex-Cover Pro D2 (US/CAN)
Smartphone for Class I, Div. 2 (for US and Canada Only)



Tab-Ex 02/03 (DZ2)
Tablet for Class I, Div. 2 & Zone 2/22



Tab-Ex 02 (DZ1)
Tablet for Class I, Div. 1 & Zone 1/21



Tab-Ex Pro D02
Tablet for Class I, Div. 2 & Zone 2/22