

High Performance Touchscreens



TOUCHSCREEN PART NUMBERS

Display Screen	Part Number	Description
15" 	HG5G-VFXT22MF-B	15 inch Color TFT LCD display Black Bezel with multimedia function
12.1" 	HG4G-VCXT22MF-B	12.1 inch Color TFT LCD display Black Bezel with multimedia function
10.4" 	HG3G-VAXT22MF-W	10.4 inch Color TFT LCD display Light Gray Bezel with multimedia function
	HG3G-VAXT22MF-B	10.4 inch Color TFT LCD display Black Bezel with multimedia function
8.4" 	HG3G-V8XT22MF-W	8.4 inch Color TFT LCD display Light Gray Bezel with multimedia function
	HG3G-V8XT22MF-B	8.4 inch Color TFT LCD display Black Bezel with multimedia function
5.7" 	HG2G-V5FT22TF-W	5.7 inch Color TFT LCD display Light Gray Bezel
	HG2G-V5FT22TF-B	5.7 inch Color TFT LCD display Black Bezel

PRODUCT DESCRIPTION

New Enhanced High Performance Series: 5.7" to 15" displays

IDEC touchscreens are redefining Human Machine Interaction. Our new High Performance 5.7", 8.4", 10.4" and 12.1" HMIs offer upgraded features and with the addition of a new 15" model, users have options for applications on any size equipment.

Featuring up to 800 cd/m² brightness, 1024 x 768 pixels high resolution displays, and over 100,000 hours of backlight life, they are the brightest, longest-lasting displays on the market.

An exceptionally wide operating temperature range of -20°C to +60°C as well as IP66F, IP67F, Type 4X, 12, 13, and Class I Div 2 approval ratings, assures reliable operation in the toughest environments. These touchscreens are built for endurance and are backed by an industry leading three-year warranty.

KEY FEATURES

- High Resolution Display: 1024 x 768 pixels (8.4", 10.4", 12.1", 15"), 640 x 480 pixels (5.7")
- Backlight light of 100,000 hours with up to 800 cd/m² brightness
- Wide range of Operating Temperature: -20°C to +60°C
- Multiple Protocols - up to 4 protocols simultaneously
- Remote Access, Monitor and Control Function
- FTP, Email, Mobile App and Custom Web Page
- Audio and Video Interface (8.4", 10.4", 12.1", 15")
- Supports Analog and Discrete I/O Expansion Modules
- IP66F/67F, Type 4X, 12 and 13, Class I Div 2
- 3 Year Warranty

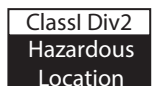

GENERAL SPECIFICATIONS

	5.7"	8.4"	10.4"	12.1"	15"
Model	HG2G-V5FT22TF	HG3G-V8XT22MF	HG3G-VAXT22MF	HG4G-VCXT22MF	HG5G-VFXT22MF
Rated Power Voltage	24V DC				
Power Voltage Range	20.4 to 28.8V DC				
Power Consumption	18W maximum 8W maximum when not using USB2 or EXT 4W maximum when Backlight OFF	25W maximum 15W maximum when not using USB2 or EXT 7W maximum when Backlight OFF			25W maximum 20W maximum when not using USB2 or EXT 7W maximum when Backlight OFF
Allowable Momentary Power Interruption	10 ms maximum				
Inrush Current	30A maximum				
Dielectric Strength	1,000V AC, 10 mA, 1 minute between power and FG terminals				
Operating Temperature	-20 to +60°C (no freezing)				
Operating Humidity	10 to 90% RH (no condensation)				
Storage Temperature	-20 to +70°C (no freezing)				
Storage Humidity	10 to 90% RH (no condensation)				
Pollution Degree	2				
Vibration Resistance	5 to 8.4 Hz amplitude 3.5 mm, 8.4 to 150 Hz acceleration 9.8 m/s ² 10 cycles (100 minutes) on each of three mutually perpendicular axes				
Shock Resistance	147 m/s ² , 11 ms 5 shocks on each of three mutually perpendicular axes				
Noise Immunity	Fast transient/burst test, Power terminals: ±2 kV, Communication line: ±1 kV (IEC/EN61131-2)				
Electrostatic Discharge	Contact ±6 kV, air ±8 kV (IEC/EN61131-2)				
Corrosion Immunity	Free from corrosive gases				
Degree of Protection *1	IP66F/IP67F (IEC 60529) (front part when mounted) Type 4X, 12, and 13				
Switching Element	Analog resistive membrane				
Operating Force	3N maximum				
Mechanical Life	1,000,000 operations				
Sound Acknowledgement	Electronic buzzer	Electronic buzzer or speaker output			
Dimensions	167.2W x 134.7H x 54.4D mm	231W x 176H x 54.4D mm	270W x 212H x 52.7D mm	314W x 240H x 54.1D mm	364.5W x 291.5H x 54.8D mm
Weight (approx.)	0.65 kg	1.25 kg	1.65 kg	2.1 kg	3.2 kg
Approvals	Safety Standards: UL61010-1, UL61010-2-201, UL12.12.01 CSA C22.2 No.61010-1-12 CSA C22.2 No.61010-2-201 CSA C22.2 No.213 Class I Div 2 Ship Classification Standards (pending): ABS, LR, NK, DNV GL				

Do not use the touchscreen in an environment subject to strong ultraviolet rays, otherwise the LCD quality will deteriorate.

*1 Protection degree of the front surface after mounting. Operation not guaranteed in certain environments.

DISPLAY SPECIFICATIONS

	5.7"	8.4"	10.4"	12.1"	15"
Model	HG2G-V5FT22TF-B or W	HG3G-V8XT22MF-B or W	HG3G-VAXT22MF-B or W	HG4G-VCXT22MF-B	HG5G-VFXT22MF-B
Display Type	Color TFT LCD				
Color Depth	65,536				
User Memory	56 MB				
Display Resolution	640W x 480H pixels	1024W x 768H pixels			
Backlight	White LED				
Backlight Life *1	100,000 hours min.				
Brightness *2	800 cd/m ²		700 cd/m ²	600 cd/m ²	650 cd/m ²
Brightness Adjustment	48 scales				
SD Card Slot	✓				
FC6A Analog & Digital I/O Cards Supported	2	4			
Ethernet Port	1 RJ-45				
USB Ports	1 Type A & 1 MiniB				
Serial Ports	2 (RS-232, RS-485, RS-422 configurable)				
Video In	—	2 Composite Video RCA connector (NTSC or PAL)			
Audio Out	—	3.5 mm audio mini-jack (stereo)			

*1 The backlight life refers to the time until the surface brightness reduces by half after continuous use at 25°C. *2 Brightness of the LCD only.

ACCESSORIES

	Part Number	Quantity	Description	5.7"	8.4"/10.4"	12.1"	15"
Programming Software	SW1A-W1C	1	Automation Organizer	✓	✓	✓	✓
USB Maintenance Cable	HG9Z-XCM2A	1	USB Programming Cable USB-MiniB (2 m)	✓	✓	✓	✓
Mounting Clip	SLD-K02	1	Replacement clip (4pcs are supplied with HMI)	✓	—	—	—
	HG9Z-4K2PN04	4	Replacement clips (4pcs are supplied with HMI)	—	✓	✓	—
	HG9Z-4K2PN06	6	Replacement clips (6pcs are supplied with HMI)				✓
Host Communication Plug	HG9Z-XT09V	1	Replacement terminal block plug (1 is supplied with HMI)	✓	—	—	—
	HG9Z-XT09	1	Replacement terminal block plug (1 is supplied with HMI)	—	✓	✓	✓
Replacement Battery	HG9Z-XR2	1	Lithium battery CR2032 (one battery is supplied with HMI)	✓	✓	✓	✓
USB Cable Lock Pin	HG9Z-XU1PN05	5	Used to lock USB cable (for USB2)	✓	✓	✓	✓
USB Panel-Mount Extension Cable	HG9Z-XCE11	1	For USB-A port (1 m)	✓	✓	✓	✓
	HG9Z-XCE21	1	For USB-mini B port (1 m)	✓	✓	✓	✓
Memory Card	HG9Z-XMS2	1	SD Memory Card (2 GB)	✓	✓	✓	✓
Protective Cover	HG9Z-2E2	1	Use with 5.7" HMI (Covers entire front of HMI)	✓	—	—	—
Protective Sheet *1	HG9Z-2D5	1	Use with 5.7" HMI (Sheet lays over LCD area)	✓	—	—	—
	HG9Z-3D8	1	Use with 8.4" HMI (Sheet lays over LCD area)	—	✓	—	—
	HG9Z-3DA2	1	Use with 10.4" HMI (Sheet lays over LCD area)	—	✓	—	—
	HG9Z-4DC	1	Use with 12.1" HMI (Sheet lays over LCD area)	—	—	✓	—
	HG9Z-5DFPN01	1	Use with 15" HMI (Sheet lays over LCD area)	—	—	—	✓
Expansion Module Clamp *2	HG9Z-XJ3	1	Short type for installing expansion I/O modules (Total width 17.6 to 41.1 mm)	✓	✓	✓	✓
	HG9Z-XJ4	1	Long type for installing expansion I/O modules (Total width 47 to 68.8 mm)	✓	✓	✓	✓
	HG9Z-XJ5	1	Extra-Long type for installing expansion I/O modules (Total width 70.1 to 93.9 mm)	✓	✓	✓	✓

*1 The protective sheet is UV resistant, however, resistance against direct sunlight in outdoor usage is not guaranteed.

*2 Use the expansion module clamp when using expansion modules.

Order the module clamp by referring to the width of the module shown in the dimensions of each module.

Note: When connecting expansion modules to the HMI's, note the limits shown below:

-Output Current flow rate at 5V: 130 mA max. (HG2G/3G/4G/5G)

-Output Current flow rate at 24V: 50 mA max. (HG5G);24V: 150 mA max. (HG2G/3G/4G)

DIMENSIONS (All dimensions in mm)

HG2G-V5 5.7"

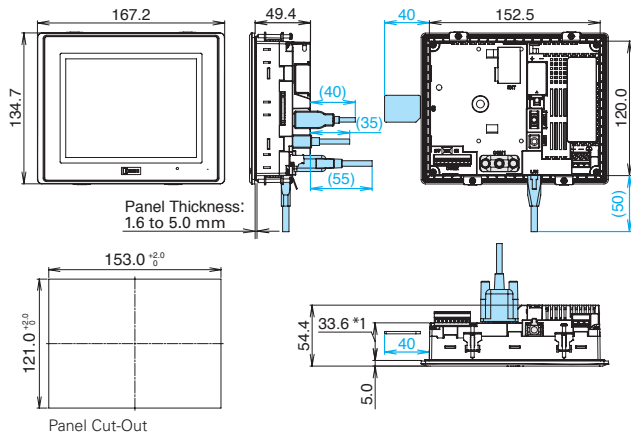

HG3G-V8 8.4"

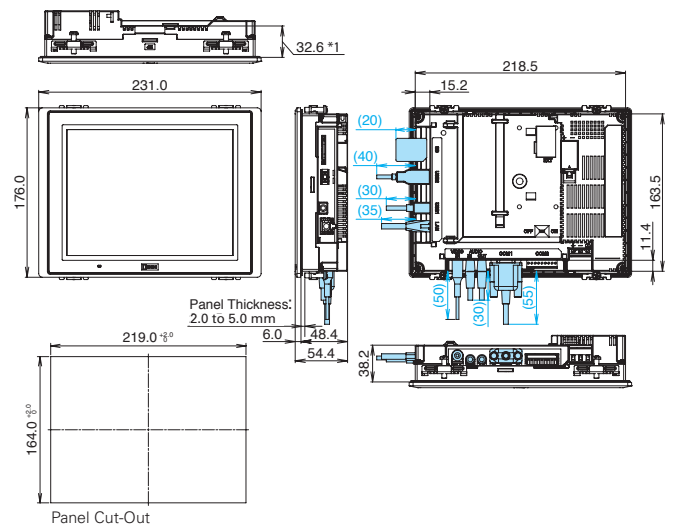

HG3G-VA 10.4"

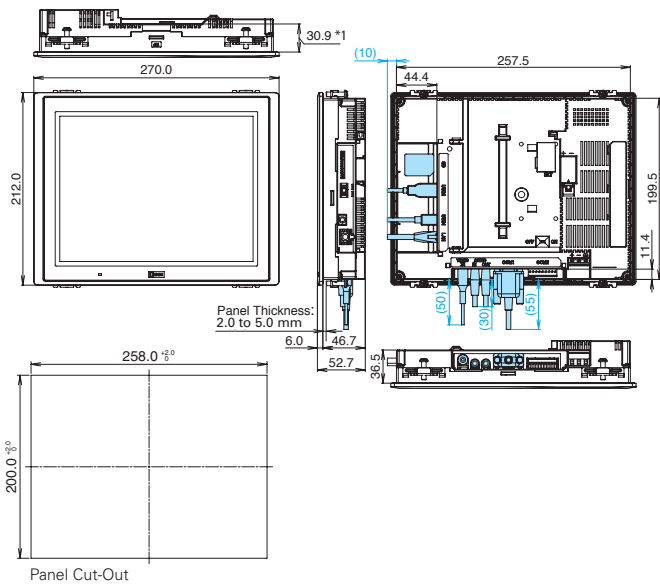

HG4G-VC 12.1"

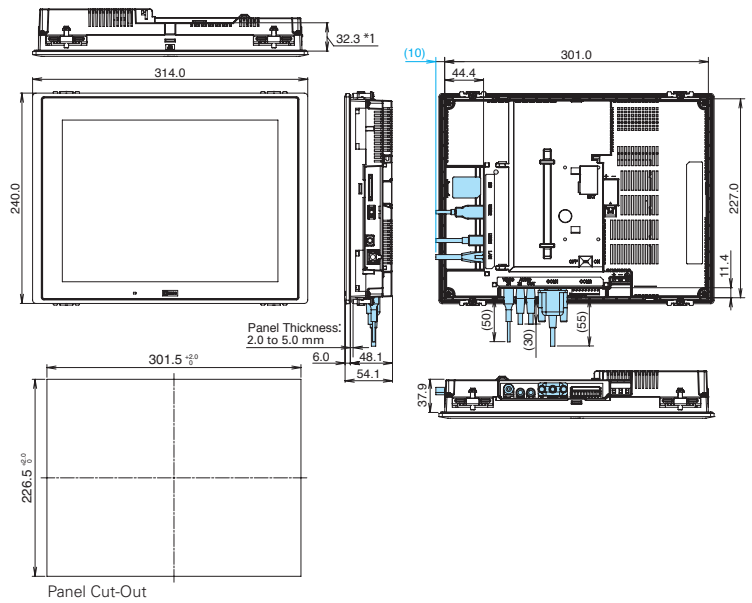

HG5G-VF 15"

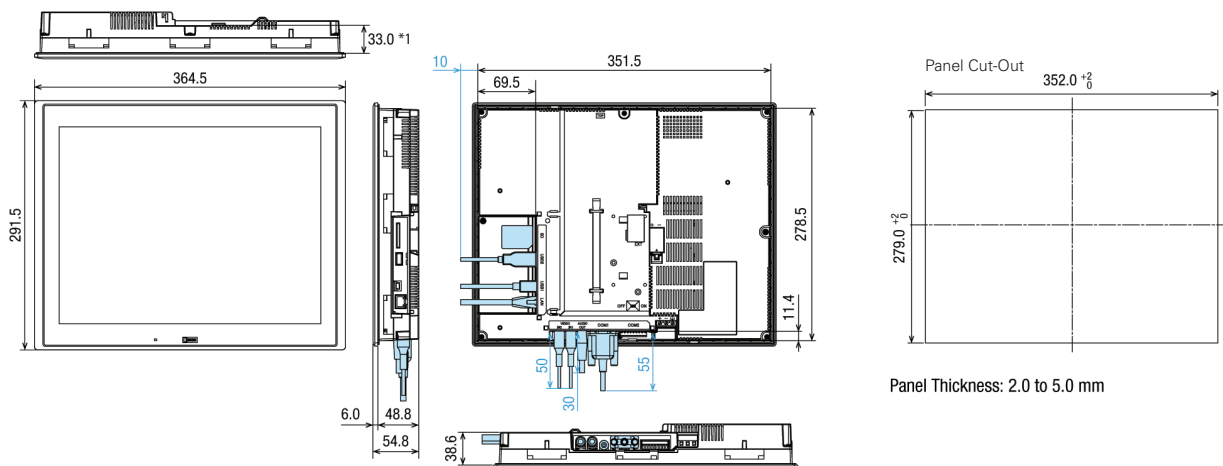

*1) Depth from the expansion module mounting surface.

Note 1: Dimensions in blue show the mounting dimensions of the cable. Note 2: The tightening torque of HG2G-V5 is 0.2 to 0.3Nm and HG3G/4G/5G-V is 0.5 to 0.6Nm.

Note 3: Do not tighten with excessive force, otherwise the HG*G-V and screen may become distorted and waterproof characteristics may be lost.

