



FRENIC-ECO PUMP

Your Pre-Engineered Solution for Pump Drives



FRENIC-ECO PUMP FEATURES

- Pre-engineered solution for pump drives**
 EcoPUMP was designed for pump applications, including advance PID control with sleep mode, broken pipe detection, pipe fill mode, submersible pump, and much more to accommodate a wide range of applications. Integrated pump specific firmware allows the user an easy set up, and EcoPUMP will automatically adjust itself to optimal operation condition.
- Energy Saving**
 Energy savings can be achieved by utilizing variable speed drives to adjust motor speed for meeting demand flow instead of mechanical devices, such as dampers or valves. Eco-PUMP allows the user to easily match pump speed to lower flow rate or pressure for optimal energy saving in pump applications.
- Many additional features and options available**
 Equipped with analog inputs directly monitoring the actual value, and application specific alarms for user friendliness. EcoPUMP provides many additional features and benefits for all types of pump applications
- Longer life and lower system cost**
 By eliminating complex controller and mechanical components, EcoPUMP reduces mechanical stress and lowers system cost as well as provides longer system life. Backed by Fuji's standard 3 year warranty in the USA, EcoPUMP is a true winner for all pump applications.

Energy saving effect compared with Fuji's previous models

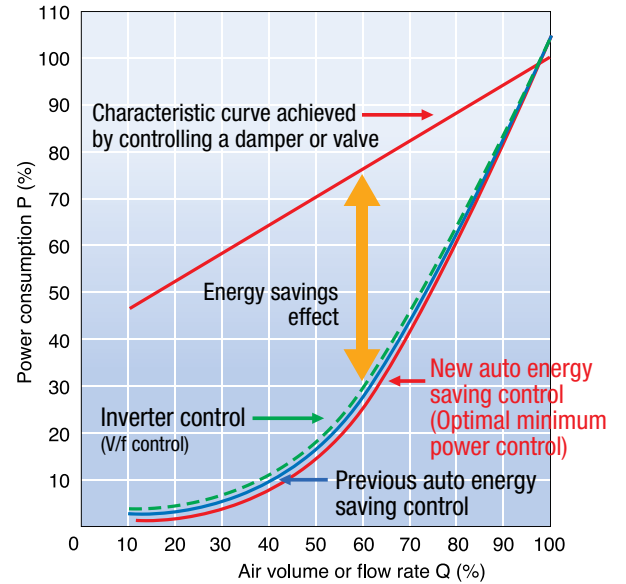

(The effect varies dependent on the motor's characteristics.)



Fuji Electric Corp. of America
3 year Standard Warranty

SIMPLIFIED SET UP FOR PRE-ENGINEERED PUMP DRIVES

- Eliminating HMI, PLC, or external control systems
- Less components for simple installation
- Less peripheral equipment
- Easy Maintenance
- Quicker Start up procedure
- Smooth Operation

10 years design life & less hardware requirements

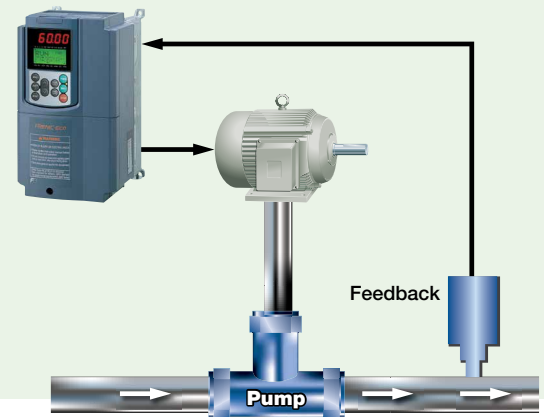

DUAL DISPLAY KEYPAD

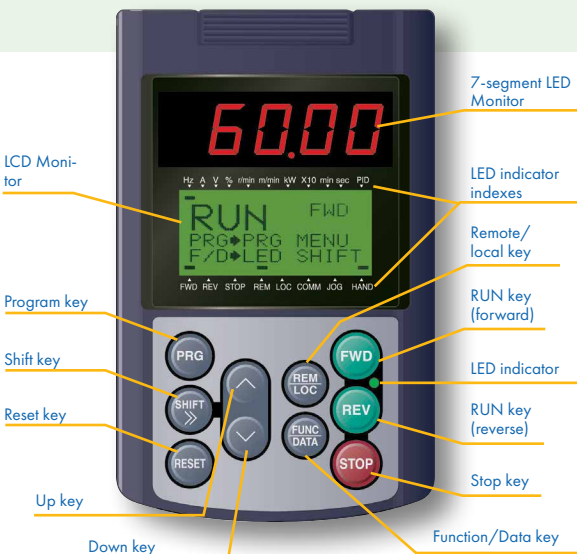

- LED for monitoring and intelligent back light LCD for programming & trouble shooting

- Works as Copy unit for easy transfer
- Available to display in actual PID unit (PIS, GPM, and etc)
- Stores up to 3 inverters programs
- Remote/local switching key allows quick changeover.
- Quick setup function codes can be customized to desired function codes.
- Load ratio can be measured (24 hours).
- Communications debugging function
- Standard RJ45 patch cable for easy extension

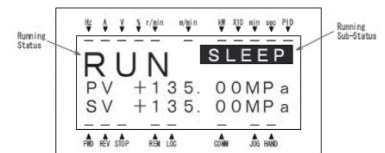

1. WIRING CONNECTION

- 1) Make sure the line, drive and motor voltage rating meeting specifications.
- 2) Make sure that Drive current rating is equal to or greater than motor FLA.
- 3) **Three Phase Input** – Connect Line to **L1/R**, **L2/S** and **L3/T** and motor cables to **U**, **V** and **W** of the drive.

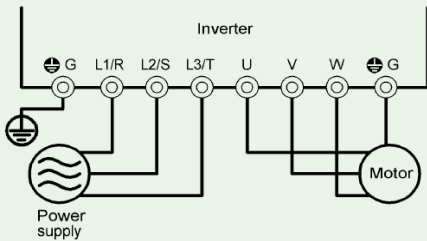

- 4) **Single Phase Input** – Connect Line to **L1/R** and **L3/T** and motor cables to **U**, **V** and **W** of the drive.

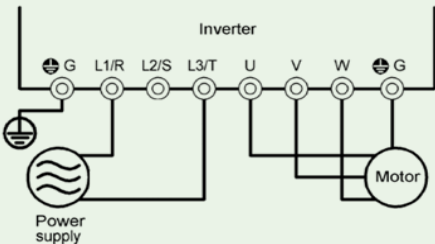

Note: Refer to "ADDITIONAL IMPORTANT PARAMETERS" H98

- 5) Connect 4-20mA Feedback Device to **[C1]+** and **[11]-** of the control card. For a Two Wire 4-20mA Device, connect **[PLC]24Vdc**, **[11]** and make jumper between **[11]** and **[CM]**.

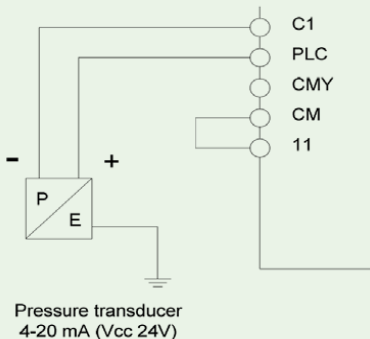

2A. USING KEYPAD QUICK SET MENU

- 1) Press **PRG** key for Programming Operation.
- 2) Select **0: QUICK SET** by using the **UP/DOWN** key, then press the **FUNC/DATA** key
- 3) Select each function by using the **UP/DOWN** key, then press the **FUNC/DATA** key
- 4) Change the data value by using **UP/DOWN** key, then press the **FUNC/DATA** key to accept the changes
- 5) Repeat **Step-3** and **4** as necessary
- 6) Press **SHIFT** to move the cursor to the right
- 7) Press **RESET** to return to the previous screen
- 8) Press **PRG** key to return the **RUN** Screen



2B. USING KEYPAD QUICK SET MENU

QUICK SET PARAMETERS		This parameters initialize basic PID pump control settings		
Code	Description	Default	User Settings	Note
F01	Frequency Command 1	0	0	Enable UP/DOWN Key on the keypad
F02	Run Command	0	0	FWD/REV/STOP from the keypad
F05	Rated Voltage at Base Frequency	208/460	###	Motor Nameplate Data Voltage
F07	Acceleration Time 1	20.0	20.0	For Submersible Pump Application go to Section-4
F08	Deceleration Time 1	20.0	20.0	For Submersible Pump Application go to Section-4
P01	Motor Poles	4	4	Motor Nameplate Data
P02	Motor Horsepower	Depends on Motor Model	###	Motor Nameplate Data
P03	Motor Rated Current	Depends on Motor Model	###	Motor Nameplate Data
J03	PID P (Gain)	0.500	0.500	Adjustable
J04	PID I (Integral time)	0.5	0.5	Adjustable
E40	PID Display Coefficient A	100	###	Scaling to convert PID process command, PID Feedback, or Analog input monitor in easy to understand mnemonic physical quantities to display

- Increase the data of J03 (P(Gain) of PID Control) within the range where the feedback signal doesn't oscillate.
- Decrease the data of J04(I (Integral Time) of PID control) within range where the feedback signal doesn't oscillate.

ADDITIONAL IMPORTANT PARAMETERS				
Code	Description	Default	User Settings	Note
F11	Electrical Motor Thermal Overload level	Same as P03	###	Set same as P03 data
F11	Restart Mode after Momentary Power Failure	0	5	Restart at the starting frequency
J02	PID Set Value	0	0	Allows the set point to be changed using the UP/DOWN Key on the keypad
H98	Protection Function	19	17	For Single Phase Input . Disable Input Phase loss Alarm (Set bit1=0)

2C. USING KEYPAD QUICK SET MENU

SLEEP/WAKE MODE		Selectable to activate or deactivate on speed or pressure		
Code	Description	Default	User Settings	Note
J56	Sleep Mode - Signal Reference	0	1	Enable for Sleep Mode Starting (Stop) reference value. (1=PID output value (MV) is referenced for Starting (Stop) level)
J57	Sleep Mode - Start Level Reference	0.00 hz	###	Sleep mode starting PID output level MV (set in Hz, which specifies MV% where MV=100%=F03). For example, when you set 54Hz in J57, Sleep mode is started when MV becomes 90%, that means Feedback value is more than the Set point value.
J58	Sleep Mode - Delay Timer	0 sec	#	Sleep Mode start delay timer
J63	Wake Mode - Input Reference	0	4	Enables Wake Mode from Sleep Mode conditions, using PID feedback 1 reference input
J64	Wake Mode - Start Level Reference	0 psi	###	Wake Mode starting level in this case PID Feedback 1 is PSI value
J65	Wake Mode - Delay Timer	0 sec	#	Wake Mode start delay timer

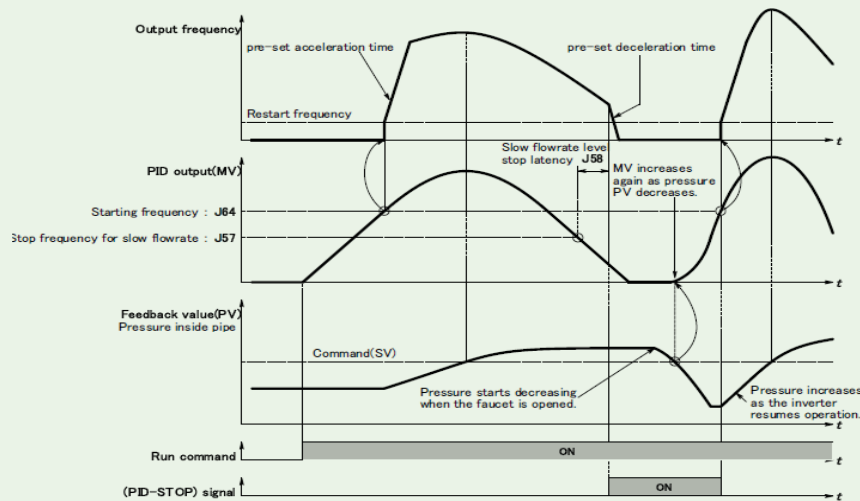

2D. USING KEYPAD QUICK SET MENU

ALARM FOR HIGH FREQUENCY		Wake frequency protection to prevent unnecessary cycling ON/OFF. Set using the number of cycles and time		
Code	Description	Default	User Settings	Note
J68	Cycling Protection for Slow Flow rate	0	#	Limit the number of cycles up to 10
J69	Maximum Cycling Protection Time	300 sec	###	Max allowable time between cycles adjustable
Number of times(J68) : 3				

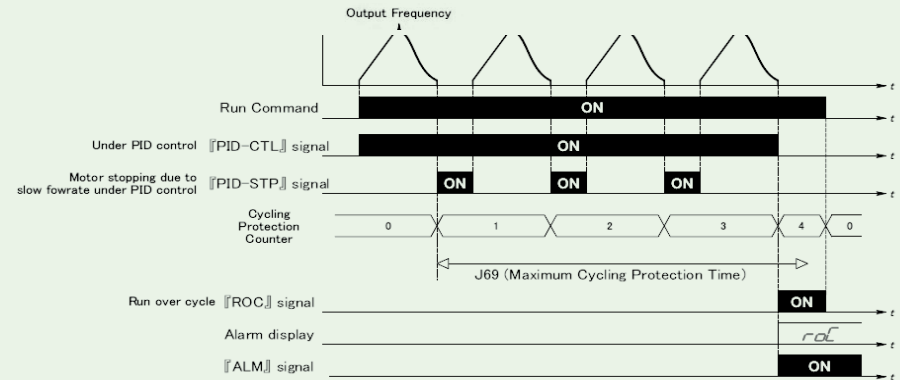

3. TEST RUN THE MOTOR

Basic PID Pump Control Setup for Section 1 & 2.

- 1) Press **PRG** until you get to the Running screen
 - Keypad **LCD** should display **SV** and **PV**
 - Keypad **LED** should blink 00.00
- 2) Pressure Setting: (in PSI unit scaled 0 to 100% range)
- 3) Feedback: **PV** (4-20mA input device; in PSI unit scaled 0 to 100% range)
- 4) Press **UP/DOWN** key to adjust **SV**
- 5) Press **FWD** key to start the motor
- 6) If motor rotates the opposite direction;
 - Press **STP** key and turn off the power to the drive
 - Swap any of the two motor cables
- 7) If motor doesn't rotate by Step-4, check the feedback **PV** value and set **SV** higher than **PV**
- 8) Check that there is no abnormal sound and vibration coming from the motor
- 9) Adjust **J03** and **J04** from the "Quick Set Parameters" and other parameters as needed

4A. COMMON PUMP APPLICATION SETUP

- 1) Choose settings based on your motor and pump specifications
- 2) Press **PRG** key for **PROGRAMMING OPERATION**
- 3) Select **1: DATA SET** by using the **UP/DOWN** key, then press the **FUNC/DATA** key
- 4) Refer to Section-2 of FRENIC-EcoPUMP Instruction manual (INR-S147-1484E) for detail

4B. COMMON PUMP APPLICATION SETUP

DETECT FEEDBACK ALARM		High and Low Pressure detection, the timer and levels can be set to alarm or fault based on the feedback		
Code	Description	Default	User Settings	Note
J11	PID Control Select Alarm Output	0	###	Must be greater than 0 to enable
J12	Upper limit alarm (AH)	999	###	Specifies the feedback upper level limit
J13	Upper alarm delay time	2 sec	2	Delay the timer to trigger the feedback alarm (AH)
J14	Lower limit alarm (AL)	-999	###	Specifies the feedback lower level limit
J15	Lower alarm delay time	120 sec	120	Delay the timer to trigger the feedback alarm (AL)

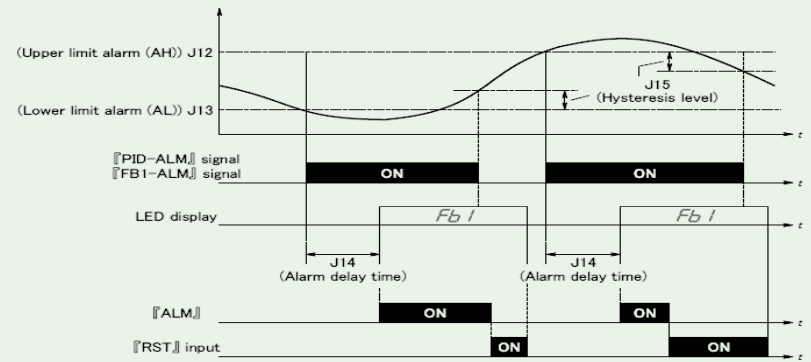

4C. COMMON PUMP APPLICATION SETUP

PIPE FILL MODE		The Fixed Hz/Speed is chosen by the user that runs until a timer expires or a separate pipe fill pressure is satisfied		
Code	Description	Default	User Settings	Note
J07	Start Pipe Fill Frequency	0.0	##	Fixed speed(Hz) of Pipe Fill Mode (Pipe Fill Mode is enabled with any value other than 0.0)
J08	Start Pipe Fill Level	0.01	###	Pipe Fill Mode Operation stops Feedback value level for PID control start
J09	Start Pipe Fill Time	0.01	###	Duration of Fixed (Hz) speed for Pipe Fill Mode
J10	Start Pipe Fill Acceleration Time	0.01	###	Acceleration time to J07 (Pipe Fill Mode)

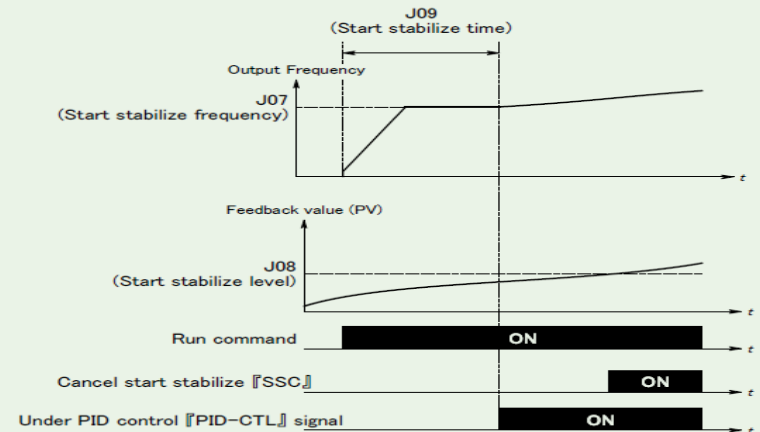

4D. SUBMERSIBLE PUMP SETUP

SUBMERSIBLE PUMP START		Sets a speed (usually 30Hz) and a timer (usually 1 sec) separate from the normal ACC/DEC times. Per the manufactures, submersible pump motors must reach 30Hz in 1 second. This is to ensure bearings and motor cooling requirements.		
Code	Description	Default	User Settings	Note
E12	Acceleration time 3	0.00	1.00	1second acceleration to 30HZ (E14)
E13	Deceleration time 3	1.00	1.00	
E14	Acc/Dec time change Hz	30.0	30.0	Acceleration ramp change HZ (E12/E13 - F07/F08)

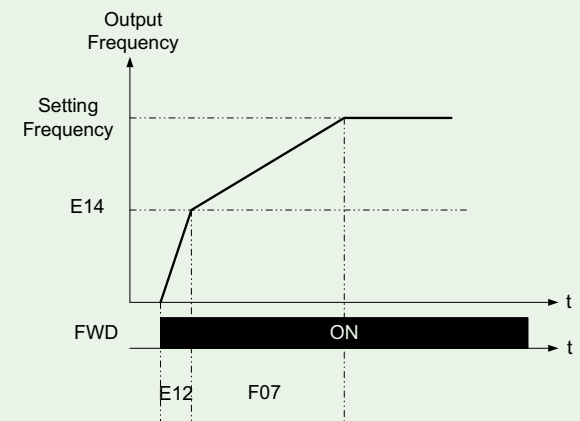

FRENIC-ECOPUMP GENERAL SPECIFICATIONS

ENVIRONMENTAL

Enclosure	Open Type (IP20/IP00), Type 1
Ambient Temperature	+14 to +122° F (-10 to +50° C) [+104° F(+40° C) for NEMA 1]
Storage Temperature	+5 to +140° F (-15 to +60° C)
Humidity	5% to 95% with no condensation
Altitude	0 to 3,300 ft. (1,000 m) without derating, derate output current above 3,300 ft. (1,000 m) per instruction manual

CODES AND STANDARDS

UL Listed per UL508C, C22.2 No. 14, EN50178:1997

Conforms to applicable NEMA ICS, NFPA, & IEC standards

ELECTRICAL

Input Voltage: Nominal - Phase	208VAC, 230VAC, 460VAC - Single or 3 Phase
Input Voltage: Tolerance, Unbalance	-15% to +10%, <2%
Input Frequency	50,60Hz +/-5%
Output Voltage: Range - Phase	0 to maximum input voltage - 3 Phase
Output Frequency	0.1 to 120Hz
Horsepower Range	1 to 125Hp @ 208V, 3 Phase Input 1/2 to 40Hp @ 208V, Single Phase Input 1 to 900Hp @ 460V, 3 Phase Input 1/2 to 250Hp @ 460V, Single Phase Input
PWM Switch Frequency	0.75 to 15kHz (1 to 25Hp for 208/230V and 1 to 30Hp for 460V) 0.75 to 10kHz (30 to 100Hp for 208/230V and 40 to 100Hp for 460V) 0.75 to 6kHz (125Hp for 208V and 125 to 900Hp for 460V)
Drive Overload Capacity	120% rated current for 1 min.
Motor Overload	Programmable (electronic)

CONTROL

Motor Control Method	PWM drive output with V/f control, includes programmable "catch-a-spinning motor" function
Motor Automatic Tuning	Automatically adjusts motor parameters for optimum performance
Speed Reference Inputs	0 to +10VDC, 4 to 20mA, Keypad, Digital Inputs, Preset Speeds, Communication Link
Speed Reference Resolution	Analog setting: 1/1000 of maximum frequency Keypad setting: 0.01Hz (99.99Hz or less)
Acceleration/Deceleration Time	0 to 3600 seconds with four user selectable patterns (S-curve [weak], S-curve [strong], Curve, & Linear), and coast to stop
Digital Input Signals	Qty 7 programmable inputs
Torque Boost	Programmable to provide additional starting torque if required
Jump Frequencies	Qty 3 programmable frequency set points with adjustable jump bandwidth of 0 to 30Hz
Restart After Momentary Power Failure	5 programmable settings to meet application requirements
Automatic Energy Savings	Minimizes motor and drive losses at constant speed
Overload Prevention Control	Reduction of drive output to avoid tripping the drive due to increase ambient temperature or motor load
Automatic Deceleration	Automatically extends the deceleration time to avoid overvoltage trips
Fully Featured PID for Pumping Applications	6 different selections for process command (set-point) 0-10Vdc or 4-20mA sensor feedback Pump functions include: sleep mode, normal/inverse operation, pipe fill mode, broken pipe detection, alarm output, etc...
Communication Interface	RS485 Modbus RTU as standard

INDICATION

Keypad LED Panel	Functions as a meter for displaying; output frequency, output amps, output voltage, torque, motor RPM, input power, PID set-point value, or PID feedback value
Keypad LCD Panel	Functions as interface for programming and troubleshooting
Digital & Analog Output Signals	Transistor outputs - qty 3 (programmable) Relay outputs - qty 1 form C and qty 1 form A (programmable) Voltage output - 0-10Vdc (programmable) Current output - 4-20mA (programmable)
Protective Trip Codes	29 unique trip codes for displaying the cause of a trip
Trip History	Last 4 trip codes and information is saved for review

Fuji Electric Corp. of America

47520 Westinghouse Drive
Fremont, CA 94539, USA

www.americas.fujielectric.com
Tel: 510.440.1060

