

Correct use

The EUCHNER enabling switch is a manually operated command switch, which allows work to be carried out in the danger area of automated production systems in **manual operating** mode. This mode must be secured with a lockable selector switch according to EN 60204, part 1.

The enabling switch must be logically gated with the machine control system in a manner that ensures compliance with the requirements applicable to safety circuits according to VDI 2854 and/or EN ISO 10218-1. Under the conditions specified therein, the enabling signal may cancel the protective action of moving safety guards. Authorized operating personnel may then enter the danger area:

- for setting up
- for observing work sequences
- for maintenance.

Important:

- The user is responsible for the integration of the device in a safe overall system. For this purpose the overall system must be validated, e.g. in accordance with EN ISO 13849-2.
- If the simplified method according to section 6.3 EN ISO 13849-1:2008 is used for validation, the Performance Level (PL) may be reduced if several devices are connected one after the other.
- The enabling switch user must assess and document remaining risks.
- If a product data sheet is included with the product, the information on the data sheet applies in case of discrepancies with the operating instructions.

Incorrect use

The enabling signal must not be simulated by fixing the switching contact in stage 2.

General

Depending on the version, buttons and a key-operated rotary switch provide additional enabling switch functionality.

Function

Stage 1: Off function, pushbutton not pressed

Stage 2: Enabling function, pushbutton pressed to center position (actuating point)

Stage 3: Positively driven Off function, pushbutton pushed to end stop

The enabling function is cancelled by releasing the pushbutton or pressing it beyond the actuating point. The enabling function does not reactivate when returning from stage 3 to stage 1. For information on the functions of the various versions, see Figure 1.

⚠

Safety precautions

⚠

Enabling switches fulfill a personal protection function. Incorrect use or tampering can lead to severe injuries to personnel.

- ⚠ All the safety and accident prevention regulations for the specific application, e.g. guidelines of the employers liability insurance associations, safety requirements of the VDI (EN ISO 10218-1, VDI 2854), EN 60204, EN 12100, EN ISO 13849, EN 61062, DIN VDE 0106 part 100, etc., must be observed.
- ⚠ Electromechanical enabling switches/devices are to be logically gated with the control system in a manner that ensures compliance with the requirements applicable to safety circuits according to EN ISO 10218-1, DIN EN 60204-1, EN ISO 13849-1, DIN EN ISO 11161 and VDI 2854.
- ⚠ No commands for potentially hazardous conditions are allowed to be initiated with enabling switches alone.

- ⚠ The safety function of enabling switches must **not** be bypassed (bridging of contacts), manipulated or otherwise rendered ineffective. The enabling switch must be protected against attempts by the operator to bypass its function.
- ⚠ Enabling switches may be used only by authorized persons who can recognize hazards in time and who are able to take appropriate action immediately.
- ⚠ Every person present in the danger area must carry his/her own enabling switch on his/her person.
- ⚠ Mounting, electrical connection and setup only by authorized personnel.

Mounting

A suitable holder must be used for enabling switches, e.g. the EUCHNER holder order no. 052406.

Electrical connection

- ⚠ In the installation of a system, the cables and wires used (except earth conductors) that can be touched without opening or removing a cover, or are laid on conductive parts external to the device, must be either double insulated or have reinforced insulation between core and surface, or be surrounded by a metal sheath of adequate current-carrying capacity in case of a short between core and sheath.
- ⚠ For use and operation as per the  requirements, a power supply with the feature "for use in class 2 circuits" must be used.
- ⚠ The max. cable length listed in the technical data must not be exceeded.

Hazards due to crushing or cutting of the connection cable must be prevented by suitable measures:

- Protecting the cable by laying it appropriately, e.g. in a protective sleeve.
- Monitoring short circuits using an evaluation unit.
- Using cable with individually screened cores. These screens are to be connected to the machine or plant earthing system. In this way cable short circuits can be detected and the control system shut-down immediately by the triggering of the short circuit protection.

Setup

Check the enabling switch (enabling function at stage 2, and positively driven at stage 3) by performing a functional check.

Service and inspection

No servicing is required, but to ensure trouble-free long-term operation, regular inspection of the electrical and mechanical function is required.

- ⚠ In the event of functional faults or damage, the enabling switch must be replaced. Repairs are only to be made by the manufacturer!

Note: The year of manufacture can be seen in the bottom, right corner of the rating plate.

Exclusion of liability under the following circumstances

- incorrect use
- non-compliance with safety regulations
- electrical connection not performed by authorized personnel
- function tests not performed

EC declaration of conformity

The manufacturer named below herewith declares that the product fulfills the provisions of the directive(s) listed below and that the related standards have been applied.

EUCHNER GmbH + Co. KG
Kohlhammerstraße 16
70771 Leinfelden-Echterdingen, Germany
Directives and standards applied:
- Machinery directive 2006/42/EC
- EMC directive 2004/108/EC
- EN 60947-5-8:2006

Leinfelden, March 2013
Dipl.-Ing. Stefan Euchner
Director

Duc Binh Nguyen
Authorized representative empowered to draw up documentation

The signed EC declaration of conformity is included with the product.

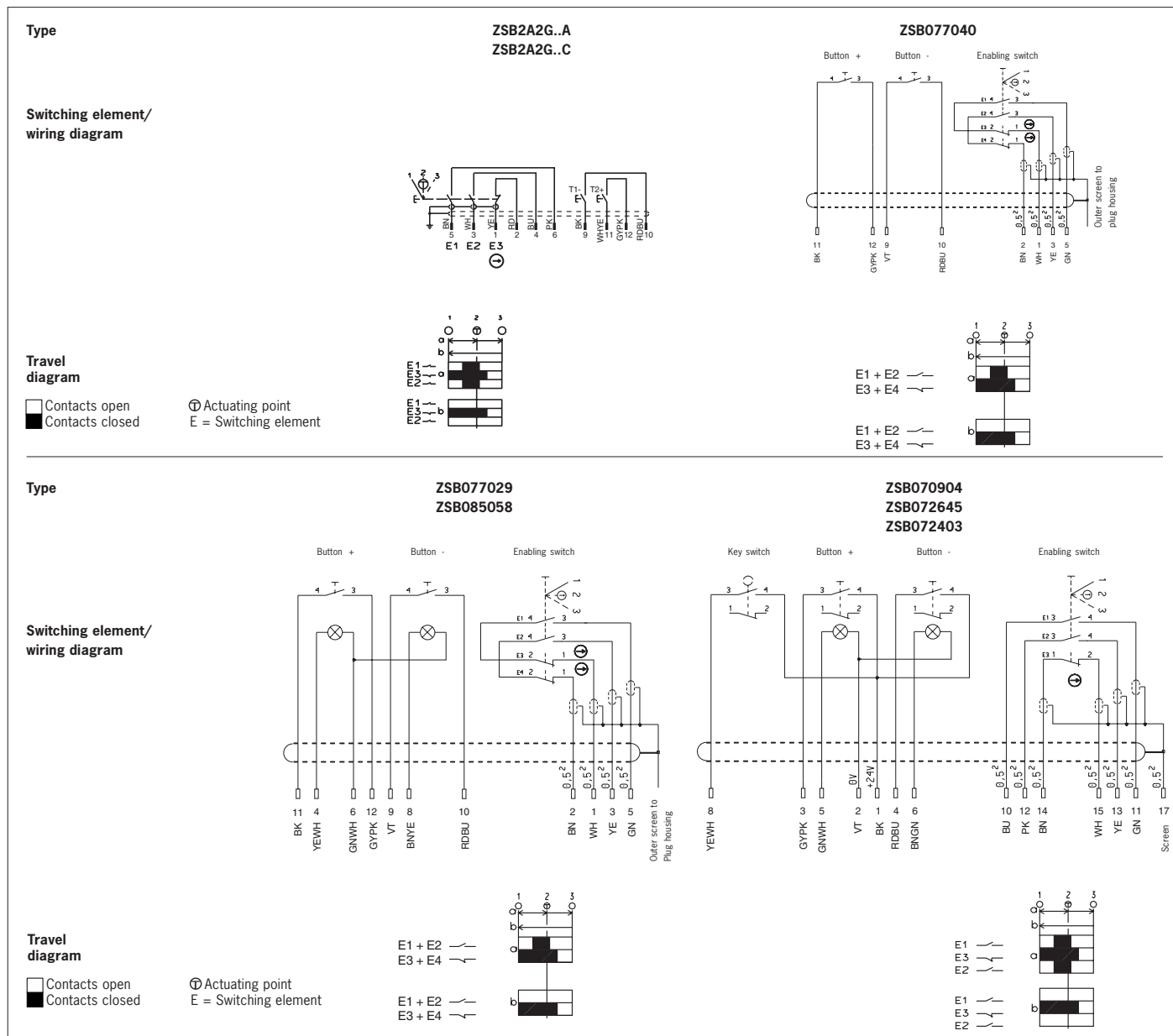

Figure 1: Function of the switching elements and wiring diagrams

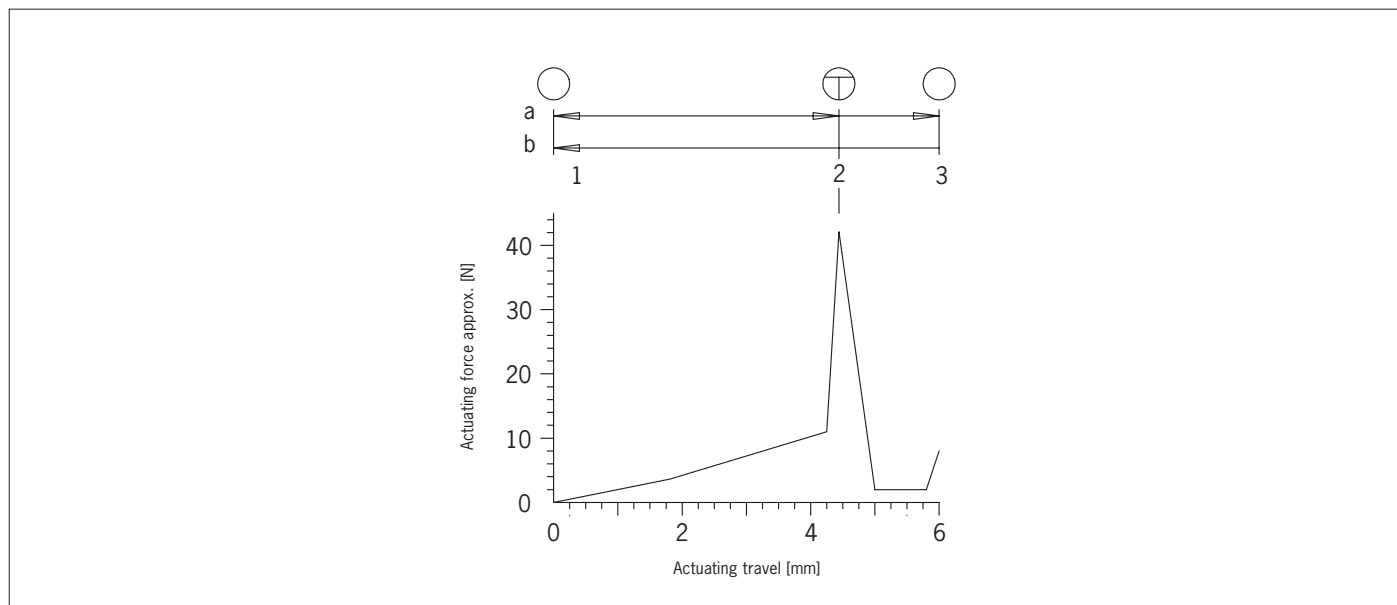

Figure 2: Diagram of actuating force as a function of actuating travel

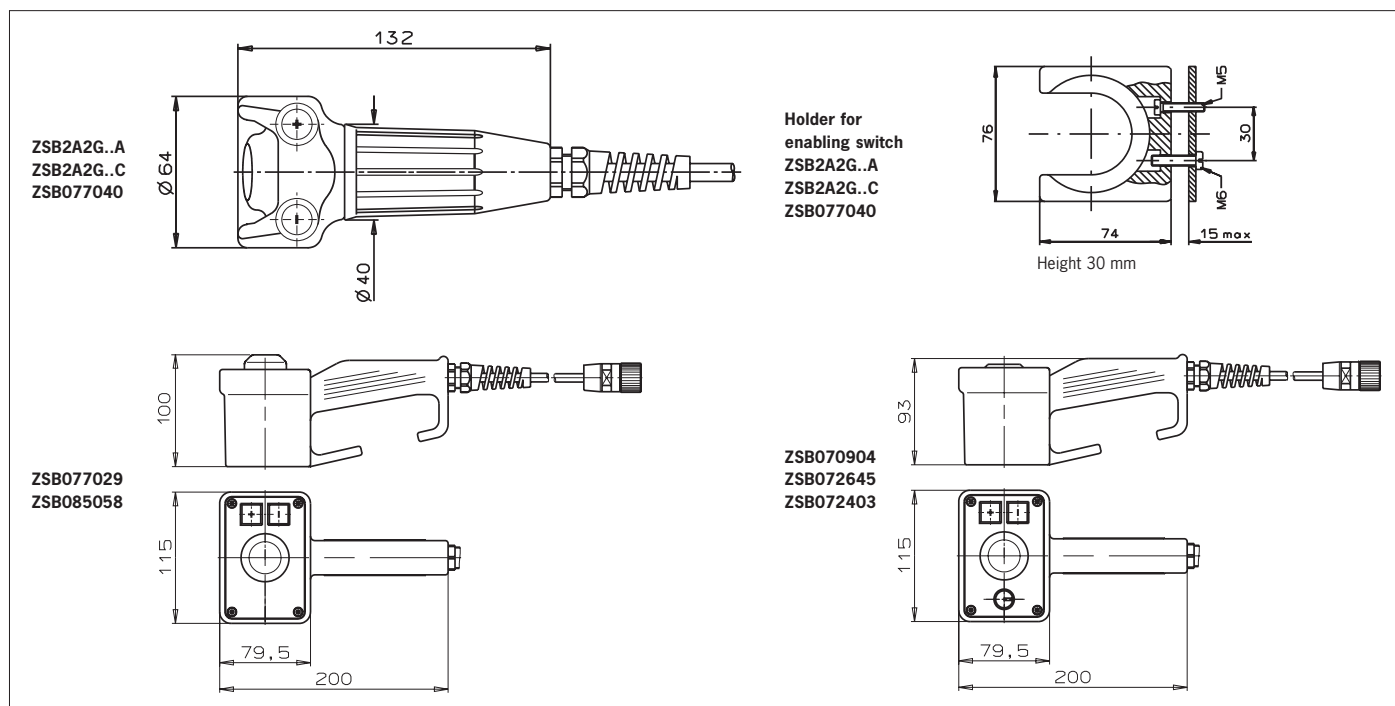

Figure 3: Dimensional drawing enabling switch ZSB and holder for enabling switch

Technical data

Parameters	Value				
Housing material	Plastic				
Degree of prot. acc. to IEC 60529	IP65				
Mechanical life min.	Position 1-2-1	1x10 ⁵ cycles			
	Position 1-2-3-1	1x10 ⁵ cycles			
Ambient temperature	-5 ... +50 °C				
Degree of contamination (external, according to EN 60947-1)	3 (industrial)				
Switching elements	See Figure 1				
Switching principle	Slow-action contact element				
Switching current, min., at 24 V	1 mA				
Switching voltage, min., at 10 mA	12 V				
Rated impulse withstand voltage	U _{imp} = 0.8 kV				
Rated insulation voltage	U _i = 250 V				
Rated short-circuit current	100 A				
Reliability figures acc. to EN ISO 13849-1					
B _{10d}	5 x 10 ⁵				
	Enabling switches		Additional elements		
Utilization category according to EN 60947-5-1	AC-15 2 A 24 V		AC 24 V 400 mA		
	DC-13 2 A 24 V		DC 24 V 100 mA		
Short circuit protection for 24 V ¹⁾	2 A gG		0.1 A gG		
Type	ZSB2A2G..A	ZSB2A2G..C	ZSB077040	ZSB077029 ZSB085058	ZSB070904/ZSB072403 ZSB072645
Special features	Direct connection to safety switch TZ...-C1803 possible				
Additional elements	2 buttons (NO contacts) T1 minus, T2 plus	2 buttons (NO contacts) T1 minus, T2 plus	2 buttons (NO contacts) T1 minus, T2 plus	2 illum. buttons (NO contacts) T1 minus, T2 plus	2 illum. buttons (NO contacts) T1 minus, T2 plus 1 key-operated rotary switch (NO contacts)
Connection	Connection cable	Plug connector 12-pin U _i = 32 V at Degree of contamination 2	Plug connector 12-pin U _i = 32 V at Degree of contamination 2	Plug connector 12-pin U _i = 32 V at Degree of contamination 2	Plug connector 17-pin U _i = 32 V at Degree of contamination 2
Connection cable enabling switch	4 x 0.5 mm ² (individually screened) + 4 x 0.5 mm ²	4 x 0.5 mm ² (individually screened) + 4 x 0.5 mm ²	4 x 0.5 mm ² (individually screened)	4 x 0.5 mm ² (individually screened) + 4 x 0.5 mm ²	4 x 0.5 mm ² (individually screened) + 4 x 0.5 mm ²
Cable length max.	25 m	25 m	25 m	25 m	25 m
Additional elements	8 x 0.14 mm ²	8 x 0.14 mm ²	4 x 0.5 mm ²	8 x 0.14 mm ²	8 x 0.14 mm ²
Weight	Approx. 1.1 kg	Approx. 1.1 kg	Approx. 1.1 kg	Approx. 1.5 kg	Approx. 1.5 kg

1) In case of operating voltages other than DC 24 V, the short circuit protection must be dimensioned accordingly and checked.