



Correct use

Safety switches series NZ are interlocking devices without guard locking (type 1). The actuator is uncoded (e.g. dog). In combination with a movable guard and the machine control, this safety component prevents dangerous machine functions from occurring while the guard is open. A stop command is triggered if the guard is opened during the dangerous machine function.

This means:

- ▶ Starting commands that cause a dangerous machine function must become active only when the guard is closed.
- ▶ Opening the guard triggers a stop command.
- ▶ Closing a guard must not cause automatic starting of a dangerous machine function. A separate start command must be issued. For exceptions, refer to EN ISO 12100 or relevant C-standards.

Devices from this series can be used as safe position encoders.

Before the device is used, a risk assessment must be performed on the machine, e.g. in accordance with the following standards:

- ▶ EN ISO 13849-1
- ▶ EN ISO 12100
- ▶ IEC 62061

Correct use includes observing the relevant requirements for installation and operation, particularly based on the following standards:

- ▶ EN ISO 13849-1
- ▶ EN ISO 14119
- ▶ EN 60204-1
- ▶ EN 1127-1

Important!

- ▶ The user is responsible for the proper integration of the device into a safe overall system. For this purpose, the overall system must be validated, e.g. in accordance with EN ISO 13849-2.
- ▶ If the simplified method according to section 6.3 of EN ISO 13849-1:2015 is used for determining the Performance Level (PL), the PL might be reduced if several devices are connected in series.
- ▶ Logical series connection of safe contacts is possible up to PL d in certain circumstances. More information about this is available in ISO TR 24119.
- ▶ If a product data sheet is included with the product, the information on the data sheet applies in case of discrepancies with the operating instructions.

Safety precautions

⚠ WARNING

Danger to life due to improper installation or due to bypassing (tampering). Safety components perform a personnel protection function.

- ▶ Safety components must not be bypassed, turned away, removed or otherwise rendered ineffective. On this topic pay attention in particular to the measures for reducing the possibility of bypassing according to EN ISO 14119:2013, section 7.
- ▶ Mounting, electrical connection, setup and service only by authorized personnel possessing special knowledge about handling safety components.

Function

The devices are used for positioning and control applications in mechanical and systems engineering. The switching contacts are actuated when the actuating element is moved from the free position to the end position. The safety contacts (⊖) are positively opened in this process (see Fig. 2).

Switching states

The detailed switching states for your switch can be found in Fig. 2. All available switching elements are described there.

Actuating element in free position

The safety contacts (⊖) are closed.

Actuating element in end position

The safety contacts (⊖) are open.

Explosion protection safety concept

Important!

In order to achieve the explosion protection stated, all the conditions in the operating instructions must be met. HIGH RISK product.



II3G Ex nR IIB T5 Gc X
II3D Ex tc IIIC T100°C Dc

...Gc X = There is no test port.

Safety switches with ATEX identification marking from EUCHNER are not safety devices as defined by the ATEX Directive.

The following components must be grounded:

- ▶ Switch/protective plate
- ▶ Trip dogs incl. rail

It is essential to mount the protective plate (conductive ESD protective paint) as shock protection. Within the stipulated operating temperature it is not to be expected that the explosive atmosphere will be drawn into the housing.

Mounting

⚠ WARNING

Danger of explosion due to improper mounting and use.

- ▶ Do not operate the switch in an atmosphere containing combustible gases, such as:
 - Carbon disulfide
 - Carbon monoxide
 - Ethylene oxide
- ▶ Protection of the switch and actuator against material deposits.
- ▶ Protection against mechanical effects on the switch:
 - To achieve the indicated explosion protection, it is essential the protective plate supplied is mounted (ESD protective paint).
 - Mount the switch so that the rear side is completely covered (no shock protection).
- ▶ An energy of 40 J must not be exceeded during insertion of the actuator. Observe the max. approach speed (see technical data) and the mass of the guard.
- ▶ The specified IP degree of protection is applicable only if the housing screws, cable entries and plug connectors are properly tightened. Observe the tightening torques.

NOTICE

Device damage due to improper mounting and unsuitable ambient conditions

- ▶ Safety switches and actuators must not be used as an end stop.
- ▶ Observe EN ISO 14119:2013, sections 5.2 and 5.3, for information about mounting the safety switch and the actuator.
- ▶ Observe EN ISO 14119:2013, section 7, for information about reducing the possibilities for bypassing an interlocking device.
- ▶ Protect the switch head against damage, as well as penetrating foreign objects such as swarf, sand and blasting shot, etc.

Changing the actuating direction

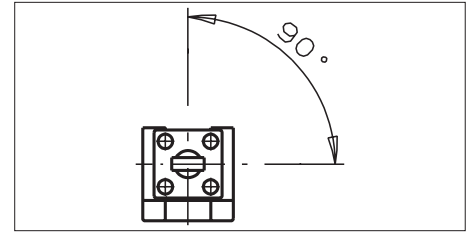

Fig. 1: Changing the actuating direction

1. Remove the screws from the actuating head.
2. Set the required direction.
3. Tighten the screws with a torque of 1.2 Nm.

Electrical connection

⚠ WARNING

Danger of explosion due to improper connection.

▶ Please observe the following notes to avoid electrostatic charging:

- All exposed ground connections must have a conductor cross-section of at least 4 mm².
- The following components must be grounded:
 - Switch/protective plate
 - Trip dogs incl. rail

▶ In order to achieve the indicated explosion protection, the supplied cable gland must be used. Observe the permissible cable diameter (6.5 ... 12 mm)!

- The cable gland is approved only for hard-wired cables and wires. The installer must provide adequate strain relief.

- Protection against loosening is to be provided with a locking nut or a suitable locking compound. As the tightening torques depend on the cables and wires used, the user must define the torque. The cable gland and the domed nut are to be firmly tightened. Inadequate tightening or excessive tightening of the connection thread or the domed nut can degrade the discharge type, the sealing or the strain relief.

▶ The connecting cable must be laid such that it is protected against mechanical damage.

⚠ WARNING

Loss of the safety function due to incorrect connection.

- ▶ Use only safe contacts (⊖) for safety functions.
- ▶ When choosing the insulation material and wires for the connections, pay attention to the required temperature resistance and the max. mechanical load!
- ▶ Strip the insulation from the ends of the individual wires over a length of 6^{±1} mm to ensure a reliable contact.

Use of the safety switch as an interlocking device for personnel protection

At least one contact (⊖) must be used. It signals the guard locking state (for terminal assignment, see Fig. 3).

The following information applies to devices with cable entry:

1. Use a suitable tool to open the desired insertion opening.
2. Fit the cable gland with the appropriate degree of protection.
3. Connect and tighten the terminals with 0.5 Nm (for terminal assignment, see Fig. 3).
4. Check that the cable entry is sealed.
5. Close the switch cover and screw in place (tightening torque 1.2 Nm).



Function test

⚠ WARNING

Fatal injury due to faults during the function test.

- ▶ Before carrying out the function test, make sure that there are no persons in the danger zone.
- ▶ Observe the valid accident prevention regulations.

Check the device for correct function after installation and after every fault.

Proceed as follows:

Mechanical function test

The actuating element must move easily. Close the guard several times to check the function.

Electrical function test

1. Switch on operating voltage.
2. Close all guards.
 - ➔ The machine must not start automatically.
3. Start the machine function.
4. Open the guard.
 - ➔ The machine must switch off and it must not be possible to start it as long as the guard is open.

Repeat steps 2 - 4 for each guard.

Inspection and service

⚠ WARNING

Danger of severe injuries due to the loss of the safety function.

- ▶ If damage or wear is found, the complete switch must be replaced. Replacement of individual parts or assemblies is not permitted.
- ▶ Check the device for proper function at regular intervals and after every fault. For information about possible time intervals, refer to EN ISO 14119:2013, section 8.2.
- ▶ Do not open, service or repair in an area in which an explosive atmosphere may be present.
- ▶ Switches and actuators must be regularly freed of dirt and cleaned.
- ▶ Avoid electrostatic charging – clean only with a damp cloth!

Inspection of the following is necessary to ensure trouble-free long-term operation:

- ▶ correct switching function
- ▶ secure mounting of all components
- ▶ damage, heavy contamination, dirt and wear
- ▶ sealing of cable entry
- ▶ loose cable connections or plug connectors.

Info: The year of manufacture can be seen in the bottom, right corner of the type label.

Exclusion of liability and warranty

In case of failure to comply with the conditions for correct use stated above, or if the safety regulations are not followed, or if any servicing is not performed as required, liability will be excluded and the warranty void.

EU declaration of conformity

The declaration of conformity is part of the operating instructions, and it is included as a separate sheet with the device.

The original EU declaration of conformity can also be found at: www.euchner.com

Service

If servicing is required, please contact:

EUCHNER GmbH + Co. KG
Kohlhammerstraße 16
70771 Leinfelden-Echterdingen
Germany

Service telephone:
+49 711 7597-500

E-mail:
support@euchner.de

Internet:
www.euchner.com

Technical data

Parameter	Value	
Housing material	Anodized die-cast alloy	
Degree of protection	IP67	
Mechanical life	30x10 ⁶ operating cycles	
Ambient temperature	-20 ... +75 °C	
Installation orientation	Any	
Approach speed, max., with actuator RS	20 m/min	
Approach speed, min.	0.1 m/min	
Actuating force at 20 °C	30 N	
Actuation frequency, max.	7,000/h	
Connection	Cable gland M20x1.5 (included)	
Clamping range for the cable gland	6.5 ... 12 mm	
Conductor cross-section (rigid/flexible)	0.34 ... 1.5 mm ²	
Rated insulation voltage	U _i = 50 V	
Rated impulse withstand voltage	U _{imp} = 2.5 kV	
Conditional short-circuit current	100 A	
Degree of contamination (external, acc. to EN 60947-1)	3 (industrial)	
Rated data for the switching elements	ES528H/ES538H	SK2121H/SK2131H/SK3131H
Switching principle of switching element	Slow-action switching contact	Slow-action switching contact
Contact material	Silver alloy, gold flashed	Silver alloy, gold flashed
Switching voltage, min., at 10 mA	12 V	12 V
Utilization category acc. to IEC 60947-5-1	AC-15 4 A 50 V DC-13 4 A 24 V	AC-15 4 A 50 V DC-13 6 A 24 V
Switching current, min., at switching voltage	1 mA DC 24 V	1 mA DC 24 V
Convent. thermal current I _{th}	10 mA DC 12 V	10 mA DC 12 V
Short circuit protection (control circuit fuse) acc. to IEC 60269-1	4 A	4 A
	4 A gG	4 A gG
Reliability values acc. to EN ISO 13849-1 depending on the switching current at 24 V DC	At DC-13 100 mA/24 V ≤ 0.1 A	
B ₁₀₀	ES528H/ES538H	2 x 10 ⁷
	SK2121H/SK2131H/SK3131H	2 x 10 ⁷
ATEX rating		
	II 3G Ex nR IIB T5 Gc X	
	II 3D Ex tc IIC T100°C Dc	

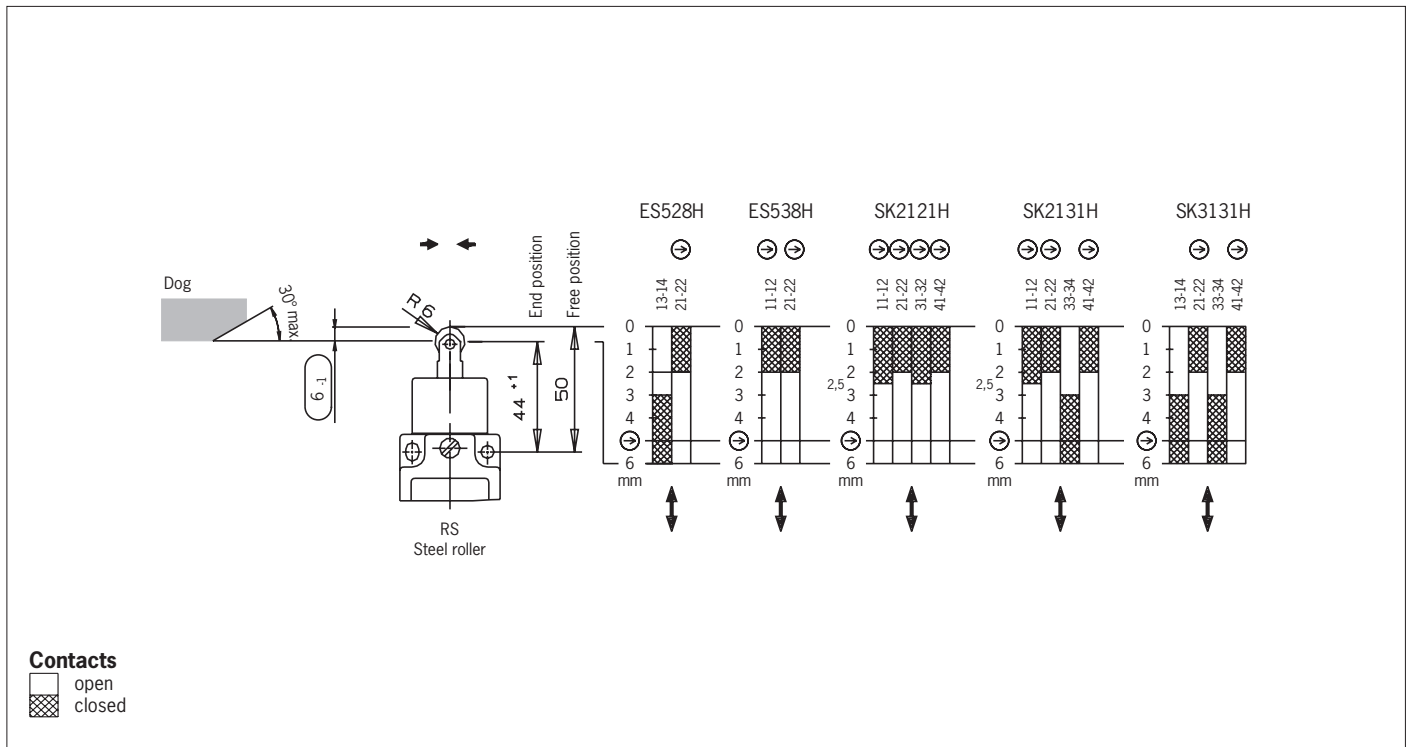

Fig. 2: Travel diagrams, actuator and approach directions

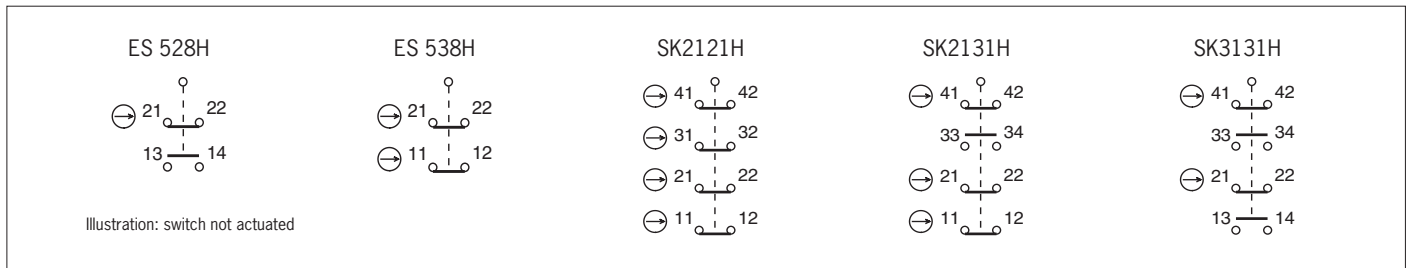

Fig. 3: Terminal assignment for switching elements

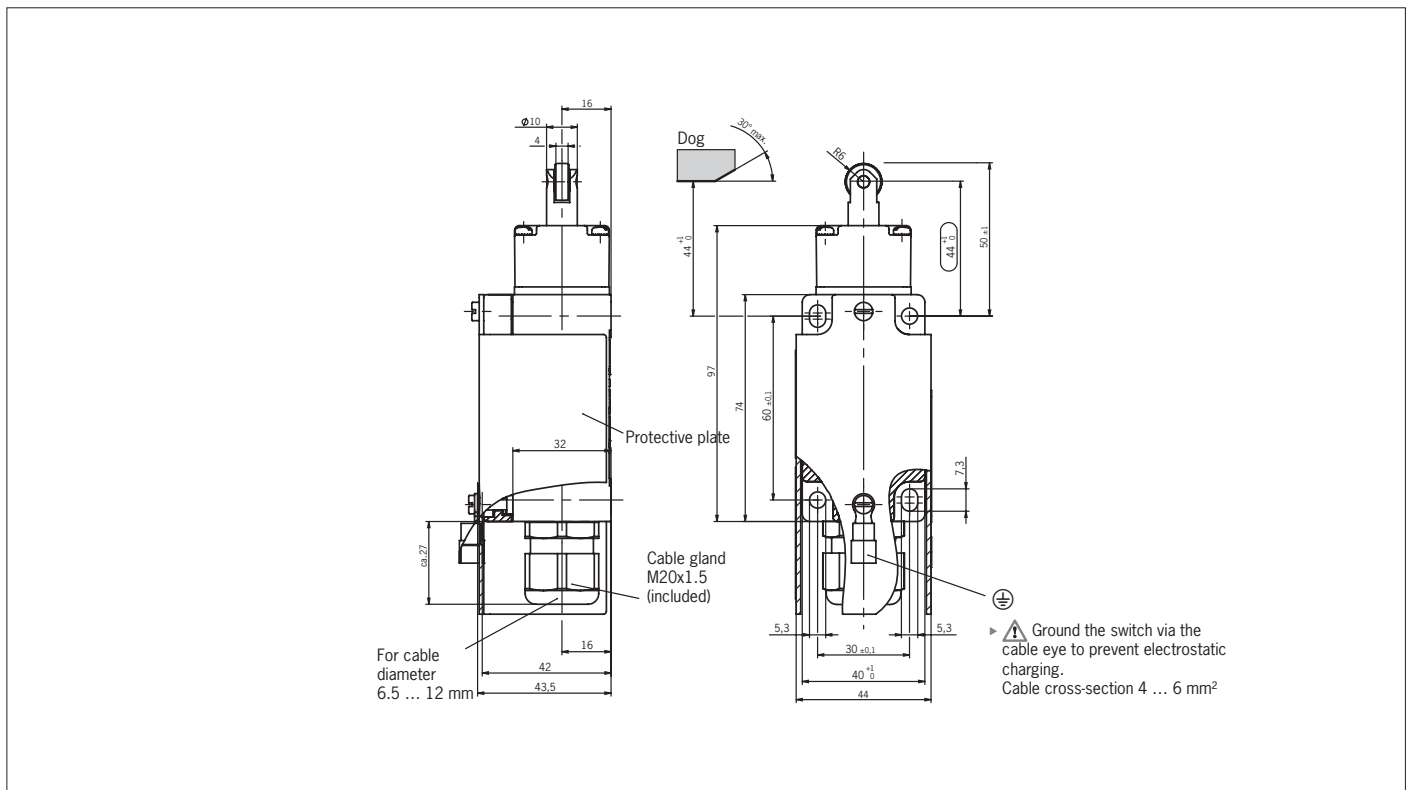

Fig. 4: Dimension drawing for NZ1...EX