

EUCHNER

Operating Instructions

Safety Systems
MGB-L..B-PN.-... (PROFINET)
With Data Structure Type B
From V3.30.0

EN

Contents

1.	About this document	4
1.1.	Scope.....	4
1.1.1.	Notes on older product versions	4
1.2.	Target group	4
1.3.	Key to symbols.....	4
1.4.	Supplementary documents	4
2.	Correct use	5
3.	Description of the safety function	7
4.	Exclusion of liability and warranty	9
5.	General safety precautions	9
6.	Function	10
6.1.	Interlocking module MGB-L0.B-PN.	10
6.2.	Locking module MGB-L1.B-PN. and MGB-L2.B-PN.	10
6.3.	Guard locking for version MGB-L1	11
6.4.	Guard locking for version MGB-L2	11
6.5.	Control of guard locking	12
6.5.1.	Case A.....	12
6.5.2.	Case B.....	13
6.5.3.	Case C.....	14
7.	System overview	15
7.1.	Bus module MGB-B-...-PN	15
7.2.	Locking/release module MGB-L-.....	16
7.3.	Handle module MGB-H.....	16
7.4.	Escape release MGB-E-... (optional)	16
7.5.	Dimension drawing	16
8.	Manual release	17
8.1.	Auxiliary release.....	17
8.2.	Lockout mechanism.....	18
8.3.	Escape release (optional)	18
8.3.1.	Preparing escape release	19
9.	Mounting	20
9.1.	Mounting lens.....	21
10.	Changing actuating direction	22
11.	Protection against environmental effects	23
12.	Controls and indicators	24

13.	Electrical connection	25
13.1.	Notes about cULus	25
13.2.	Connections on the bus module	26
13.2.1.	Terminal assignment for version with push-pull plugs.....	26
13.2.2.	Terminal assignment for version with 7/8" and M12 plugs, d-coded	26
14.	Setup	27
14.1.	Integrating into PROFINET and PROFIsafe	27
14.2.	Replacement of an MGB system without programming device	27
14.3.	Resetting system to factory settings	27
14.4.	Teach-in operation (only for MGB unicode).....	28
14.5.	Mechanical function test.....	28
14.6.	Electrical function test.....	28
14.7.	PROFINET data bytes (data blocks for non-safe functions)	29
14.8.	Data blocks for MGB modules.....	30
14.8.1.	Data block for MGB bus module	30
14.8.2.	Data block for MGB locking module L0, L1 or L2.....	31
14.8.3.	Data block for MGB control module	31
14.9.	Data blocks of individual functions at a glance	32
14.9.1.	Data block for signal stack module function (optional)	32
14.9.2.	Data block for emergency stop function (optional)	32
14.9.3.	Data block for enabling switch function (optional).....	33
14.9.4.	Data block for operating mode selector function (optional)	33
14.9.5.	Data block for diagnostic function	34
14.10.	PROFIsafe data bytes (data block for safe functions).....	35
14.10.1.	Data block for PROFIsafe	36
15.	MGB system diagnostic messages.....	37
16.	PROFINET alarms	38
16.1.	Fault in stacklight module	38
17.	System status table	39
18.	Technical data	40
18.1.	Dimension drawings.....	41
19.	Troubleshooting and assistance.....	45
19.1.	Latching fault when actuating the escape release	45
19.2.	Resetting errors	45
19.3.	Troubleshooting help on the Internet.....	45
19.4.	Mounting help on the Internet.....	45
19.5.	Application examples	45
20.	Service	46
21.	Inspection and service	46
22.	Declaration of conformity	47

1. About this document

1.1. Scope

These operating instructions are valid for all MGB-L..B-PN-... (PROFINET) and With Data Structure Type B. These operating instructions, the document *Safety information* and any enclosed data sheet form the complete user information for your device.

Series	Guard locking types	System families	Product versions
MGB	L0 (without guard locking)	...PN...	from V3.30.1
	L1 (guard locking by spring force)		from V3.30.1
	L2 (guard locking by solenoid force)		from V3.30.0





1.1.1. Notes on older product versions

Products with lower product versions or without a version number are not described by these operating instructions. Please contact our support team in this case.

1.2. Target group



Design engineers and installation planners for safety devices on machines, as well as setup and servicing staff possessing special expertise in handling safety components.

1.3. Key to symbols

Symbol/depiction	Meaning
	Printed document
	Document is available for download at www.euchner.com
 DANGER WARNING CAUTION	Safety precautions Danger of death or severe injuries Warning about possible injuries Caution Slight injuries possible
 NOTICE Important!	Notice about possible device damage Important information
Tip	Useful information

1.4. Supplementary documents

The overall documentation for this device consists of the following documents:

Document title (document number)	Contents	
Safety information (2525460)	Basic safety information	
Operating instructions (2115174)	(this document)	
Possibly enclosed data sheet	Item-specific information about deviations or additions	

	Important! Always read all documents to gain a complete overview of safe installation, setup and use of the device. The documents can be downloaded from www.euchner.com . For this purpose enter the doc. no. in the search box.
-------------------------------------------------------------------------------------	----------------------------------------------------------------------------------------------------------------------------------------------------------------------------------------------------------------------------------------------------------------------------------

2. Correct use

The following applies to MGB-L0:

The system comprises at least one interlocking module MGB-L0-... and one handle module MGB-H...

The safety system MGB is an interlocking device without guard locking (type 4). Devices with unicode evaluation possess a high coding level, devices with multicode evaluation possess a low coding level.

In combination with a movable guard and the machine control, this safety component prevents dangerous machine functions from occurring while the guard is open. A stop command is triggered if the guard is opened during the dangerous machine function.

This means:

- Starting commands that cause a dangerous machine function must become active only when the guard is closed.
- Opening the guard triggers a stop command.
- Closing a guard must not cause automatic starting of a dangerous machine function. A separate start command must be issued. For exceptions, refer to EN ISO 12100 or relevant C-standards.

The following applies to MGB-L1/MBG-L2:

The system comprises at least one locking module MGB-L1-.../MGB-L2-... and one handle module MGB-H...

The safety system MGB is an interlocking device with guard locking (type 4). Devices with unicode evaluation possess a high coding level, devices with multicode evaluation possess a low coding level.

In combination with a movable guard and the machine control, this safety component prevents the guard from being opened while a dangerous machine function is being performed.

This means:

- Starting commands that cause a dangerous machine function must become active only when the guard is closed and locked.
- The guard locking must not be released until the dangerous machine function has ended.
- Closing and locking a guard must not cause automatic starting of a dangerous machine function. A separate start command must be issued. For exceptions, refer to EN ISO 12100 or relevant C-standards.

For MGB-L0/MGB-L1/MGB-L2

The interlocking module MGB-LOB-PN.-... and the locking module MGB-L1B-PN.-.../MGB-L2B-PN.-... are operated as IO devices in the PROFINET (PROFIsafe).

Before the device is used, a risk assessment must be performed on the machine, e.g. in accordance with the following standards:

- EN ISO 13849-1
- EN ISO 12100
- IEC 62061

Correct use includes observing the relevant requirements for installation and operation, particularly based on the following standards:

- EN ISO 13849-1
- EN ISO 14119
- EN 60204-1

The safety system MGB can be combined only with the intended modules in the MGB system family.

On the modification of system components, Euchner provides no warranty for function

The customer is responsible for the safe overall function, especially for the safe integration into the PROFIsafe environment.



Important!

- The user is responsible for the proper integration of the device into a safe overall system. For this purpose, the overall system must be validated, e.g. in accordance with EN ISO 13849-2.



Important!

- › Correct use requires observing the permissible operating parameters (see chapter 18. *Technical data on page 40*).
- › If a product data sheet is included with the product, the information on the data sheet applies in case of discrepancies with the operating instructions.

Table 1: Possible combinations for MGB components

Evaluation unit	Handle module	
		MGB-H... from V2.0.0
MGB...PN From V3.30.0		●
Key to symbols	●	Combination possible

3. Description of the safety function

Devices from this series feature the following safety functions:

The following applies in case of active guard lock monitoring (ÜK, bit $s_{I1.1}$):

**Monitoring of guard locking and the position of the guard
(interlocking device with guard locking according to EN ISO 14119)**

- Safety function (see chapter 6. *Function on page 10*):
 - When guard locking is released, safety bit $s_{I1.1}$ (ÜK) = 0 (monitoring of the locking element).
 - When the guard is open, safety bit $s_{I1.0}$ (SK) = 0.
 - Guard locking can be activated only when the bolt tongue is located in the locking module (prevention of inadvertent locking position (faulty closure protection)).
- Safety characteristics: category, Performance Level, PFH_D (see chapter 18. *Technical data on page 40*).

Control of guard locking (safety bit $s_{O0.0}$)

- Safety function
If the device is used as guard locking for personnel protection, control of guard locking must be regarded as a safety function.

The safety level of guard locking control is determined by the device $PFH_{D_{int}}$ and by the external control (e.g. $PFH_{D_{ext}}$ of the standstill monitor).

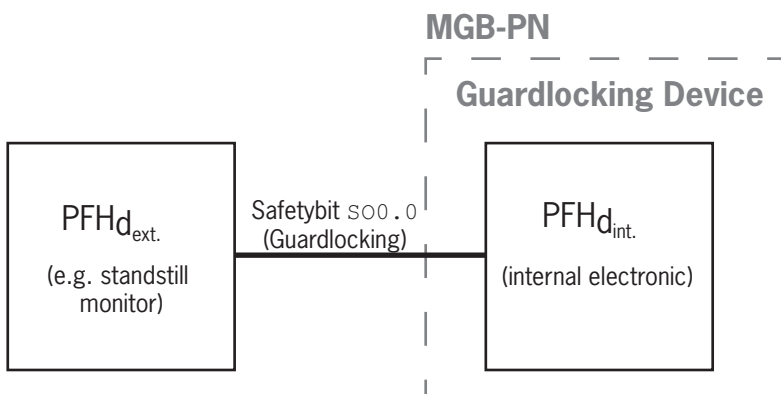

- Safety characteristics: category, Performance Level, PFH_D (see chapter 18. *Technical data on page 40*).

The following applies in case of inactive guard lock monitoring (ÜK, bit $s_{I1.1}$):

**Monitoring of the guard position
(interlocking device according to EN ISO 14119)**

- Safety function: When the guard is open, safety bit $s_{I1.0}$ (SK) = 0. (See chapter 6. *Function on page 10*.)
- Safety characteristics: category, Performance Level, PFH_D (see chapter 18. *Technical data on page 40*).

The following applies to devices with emergency stop:

Emergency stop
(emergency stop device according to EN ISO 13850)

- › Safety function: evaluation of emergency stop
- › Safety characteristics: B_{10D} value for the emergency stop and PFH_D for the evaluation electronics (see chapter 18. *Technical data on page 40*)

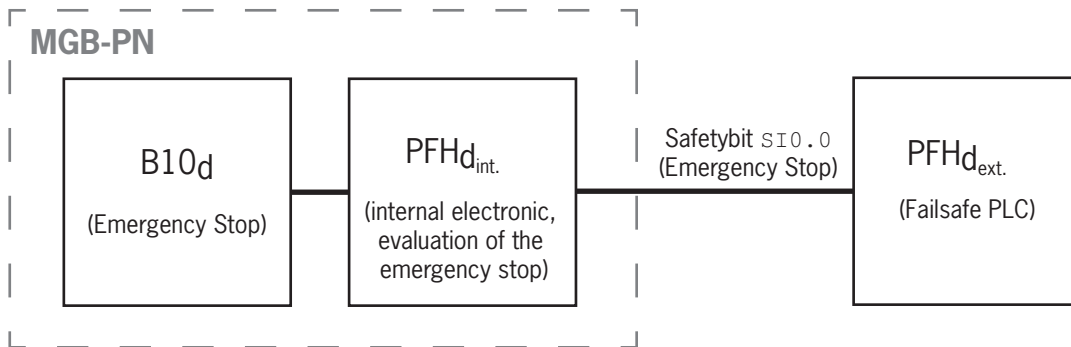

The following applies to devices with connection for enabling switch:

Enabling function

- › Safety function: evaluation of a connected enabling switch
- › Safety characteristics: B_{10D} value for the enabling switch (see manufacturer's information) and PFH_D for the evaluation electronics (see chapter 18. *Technical data on page 40*)

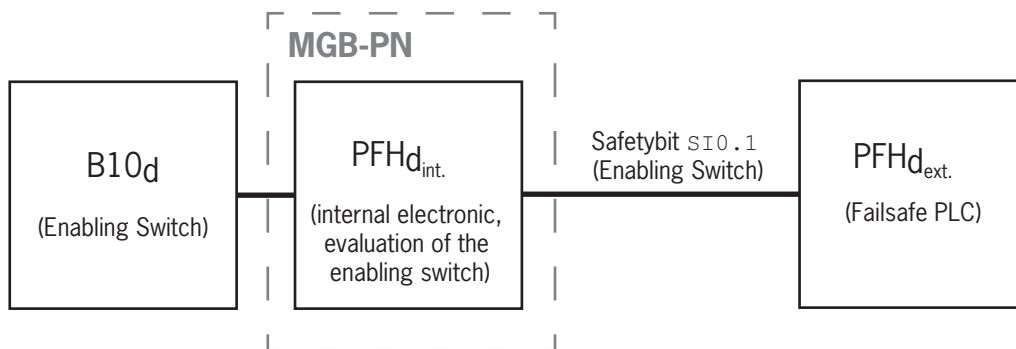

For devices with multi-position switch:

Detection of the switch position

- › Safety function: evaluation of the switch position, e.g. for safe switchover between individual operating modes
- › Safety characteristics: PFH_D for the evaluation electronics (see chapter 18. *Technical data on page 40*). The switch position is scanned electronically. There is therefore no B_{10D} value for the switch.

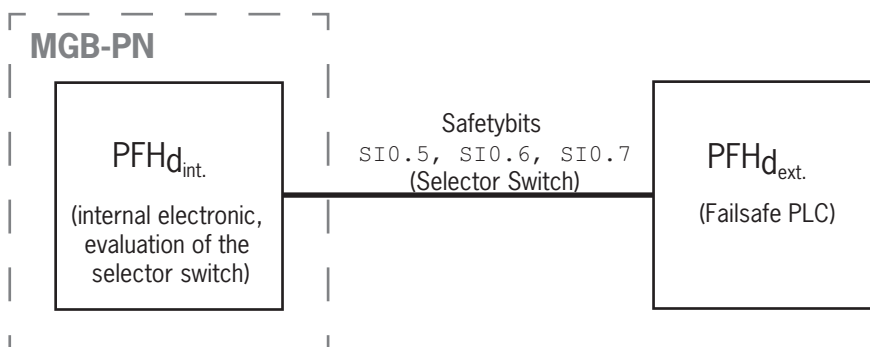

4. Exclusion of liability and warranty

In case of failure to comply with the conditions for correct use stated above, or if the safety regulations are not followed, or if any servicing is not performed as required, liability will be excluded and the warranty void.

5. General safety precautions

Safety switches fulfill personnel protection functions. Incorrect installation or tampering can lead to fatal injuries to personnel.

Check the safe function of the safeguard particularly

- › after any setup work
- › after the replacement of an MGB component
- › after an extended period without use
- › after every fault
- › after any change to the DIP switch settings

Independent of these checks, the safe function of the safeguard should be checked at suitable intervals as part of the maintenance schedule.



WARNING

Danger to life due to improper installation or due to bypassing (tampering). Safety components perform a personnel protection function.

- › Safety components must not be bypassed, turned away, removed or otherwise rendered ineffective. On this topic pay attention in particular to the measures for reducing the possibility of bypassing according to EN ISO 14119:2013, section 7.
- › The switching operation is allowed to be triggered only by the intended handle module MGB-H... that is positively fastened to the guard.
- › Prevent bypassing by means of replacement actuators (only for multicode evaluation). For this purpose, restrict access to actuators and to keys for releases, for example.
- › Mounting, electrical connection and setup only by authorized personnel possessing the following knowledge:
 - specialist knowledge in handling safety components
 - knowledge about the applicable EMC regulations
 - knowledge about the applicable regulations on operational safety and accident prevention.



Important!

Prior to use, read the operating instructions and keep these in a safe place. Ensure the operating instructions are always available during mounting, setup and servicing. For this reason you should archive a printed copy of the operating instructions. You can download the operating instructions from www.euchner.com.

6. Function

6.1. Interlocking module MGB-L0.B-PN.

Together with a handle module, the interlocking module makes it possible to interlock movable guards. The combination also serves as a mechanical door stop at the same time.

The following switch-on condition applies to safety bit $SI1.0$ (SK):

- Guard closed (T)
- Bolt tongue inserted into interlocking module (R)

See also chapter 17. *System status table on page 39* and chapter 14.10. *PROFIsafe data bytes (data block for safe functions) on page 35*.

The interlocking module detects the position of the guard and the position of the bolt tongue.

The bolt tongue in the handle module is moved into and out of the interlocking module by actuating the door handle.

6.2. Locking module MGB-L1.B-PN. and MGB-L2.B-PN.

Together with a handle module, the locking module makes it possible to lock movable guards. The combination also serves as a mechanical door stop at the same time.



Important!

To operate the device as guard locking for personnel protection according to EN ISO 14119, the signals for door position (T=PROFIsafe bit $SI0.2$), bolt position (R= PROFIsafe bit $SI0.3$) and guard lock monitoring (Z= PROFIsafe bit $SI0.4$) must be polled in a logical AND operator. This operator is already implemented in the PROFIsafe data block (ÜK=safety bit $SI1.1$).

As an alternative, you can also link the bits $SI0.2$ to $SI0.4$ individually in your control system.

The following switch-on condition applies to safety bit $SI1.1$ (ÜK):

- Guard closed (T)
- Bolt tongue inserted into locking module (R)
- Locking arm in locking position (guard lock monitoring) (Z)

See also chapter 17. *System status table on page 39* and chapter 14.10. *PROFIsafe data bytes (data block for safe functions) on page 35*.

The locking module detects the position of the guard and the position of the bolt tongue. The position of the locking arm is also monitored.

The bolt tongue in the handle module is moved into and out of the locking module by actuating the door handle.

When the bolt tongue is fully inserted into the locking module, the locking arm locks the bolt tongue in this position. Depending on version, this locking is by spring force or solenoid force.

6.3. Guard locking for version MGB-L1

(guard locking actuated by spring force and released by power-ON)

Activating guard locking: close guard, no voltage at the solenoid (safety bit $sO\ 0.0 = 0$).

Releasing guard locking: apply voltage to the solenoid (safety bit $sO\ 0.0 = 1$).

The spring-operated guard locking functions in accordance with the closed-circuit current principle. If the voltage is interrupted at the solenoid, the guard locking remains active and the guard cannot be opened directly.



Important!

If the guard is open when the power supply is interrupted and is then closed, guard locking is activated. This can lead to persons being locked in unintentionally.

As long as the locking arm is closed, the bolt tongue cannot be pulled out of the locking module and the guard is locked.

When voltage is applied to the guard locking solenoid, the locking arm is opened and bolt tongue is released. The guard can be opened.

6.4. Guard locking for version MGB-L2

(guard locking actuated by power-ON and released by spring force)



Important!

Use as guard locking for personnel protection is possible only in special cases, after strict assessment of the accident risk (see EN ISO 14119:2013, section 5.7.1)!

Activating guard locking: apply voltage to the solenoid (safety bit $sO\ 0.0 = 1$).

Releasing guard locking: disconnect voltage from the solenoid (safety bit $sO\ 0.0 = 0$).

The magnetically actuated guard locking operates in accordance with the open-circuit current principle. If the voltage is interrupted at the solenoid, the guard locking is released and the guard can be opened directly!

The guard can be opened as long as no voltage is applied to the guard locking solenoid.

When voltage is applied to the guard locking solenoid, the locking arm is held in the locked position and the guard is locked.

6.5. Control of guard locking

From MGB version V2.36.4, the factory setting ensures that control is possible only from the safe control area.

By changing the parameters in the configuration tool of your control system, it can be set whether bit $o\ 0.0$ (in the safe data block for the MGB locking module) is evaluated as well (see chapter 14.8.2. Data block for MGB locking module L0, L1 or L2 on page 31).



Important!

The following applies to MGB-L2:

Control of the guard locking via the safe control area does not provide increased safety, as the device-internal control of the guard locking is only of single-channel design.



Important!

The following functions depend on the MGB version, the version of the GSD file and the settings made there.

Compare the specified versions with those on your device and in your GSD file. The version number of your MGB can be found on the type label (format: VX.XX.X).

MGB version	GSD version	Continue in section ...
up to and including V2.35.4	..._110026- 20110725	Case A
	..._110026- 20110815	Case A
From V3.30.0	..._110026- 20110725	Case B
	..._110026- 20110815 or newer	Case C

6.5.1. Case A

You have an MGB with a version number of V2.35.4 and a GSD file with a version number of ..._110026-20110725 or older. Or you have an MGB with a version number of V2.35.4 and a GSD file with a version number from ..._110026-20110815.

The guard locking solenoid is controlled if

▸ bit $o\ 0.0$ **OR** bit $so\ 0.0 = 1$

Truth table

PROFINET bit $o\ 0.0$	PROFIsafe bit $so\ 0.0$	Guard locking with	
		MGB-L1...	MGB-L2...
0	0	Active	Inactive
0	1	Inactive	Active
1	0	Inactive	Active
1	1	Inactive	Active

What must be observed?

Guard locking can be controlled from the non-safe control area. The combination with the more up-to-date GSD file allows a parameter to specify which bits are to be used for control. However, the device does not support this function. In other words, the setting in your configuration software remains ineffective.

6.5.2. Case B

You have an MGB with a version number of V3.30.0 and a GSD file with a version number of ..._110026-20110725 or older.

The guard locking solenoid is controlled if

for MGB-L1...

▸ bit SO 0.0 = 1

for MGB-L2...

▸ bit O 0.0 **OR** bit SO 0.0 = 1

Truth table

PROFINET bit O 0.0	PROFIsafe bit SO 0.0	Guard locking with	
		MGB-L1...	MGB-L2...
0	0	Active	Inactive
0	1	Inactive	Active
1	0	Active	Active
1	1	Inactive	Active

What must be observed?

Bit O 0.0 does not have any function with version MGB-L1.... In existing installations in which old devices are replaced with new ones (e.g. due to defect), malfunctions can occur if control via bit O 0.0 was programmed in the PLC.

Remedy:

1. Replace the old GSD file with a version from ..._110026-20110815.
2. In the parameter *Locking module – solenoid control*, activate non-safe control of the guard locking solenoid via bit O 0.0.
3. Set bit SO 0.0 permanently to the value 1.

➔ The guard locking solenoid is controlled exclusively via bit O 0.0

or

▸ Change the control bit from O 0.0 to SO 0.0 in your PLC program.

6.5.3. Case C

You have an MGB with a version number of V3.30.0 and a GSD file with a version number from ..._110026-20110815.

The guard locking solenoid is controlled if:

- bit SO 0.0 = 1 (factory setting)

Truth table

PROFINET bit O 0.0 Not relevant	PROFIsafe bit SO 0.0	Guard locking with	
		MGB-L1...	MGB-L2...
0	0	Active	Inactive
0	1	Inactive	Active
1	0	Active	Inactive
1	1	Inactive	Active

What must be observed?

You can define in the GSD file whether bit O 0.0 may be used for control in addition to bit SO 0.0. The setting is specified in the parameter *Locking module - solenoid control*.

If O 0.0 is additionally used, the guard locking solenoid is controlled if
for MGB-L1...

- bit SO 0.0 **AND** bit O 0.0 = 1

for MGB-L2...

- bit SO 0.0 **OR** bit O 0.0 = 1

Truth table

PROFINET bit O 0.0	PROFIsafe bit SO 0.0	Guard locking with	
		MGB-L1...	MGB-L2...
0	0	Active	Inactive
0	1	Active	Active
1	0	Active	Active
1	1	Inactive	Active

7. System overview

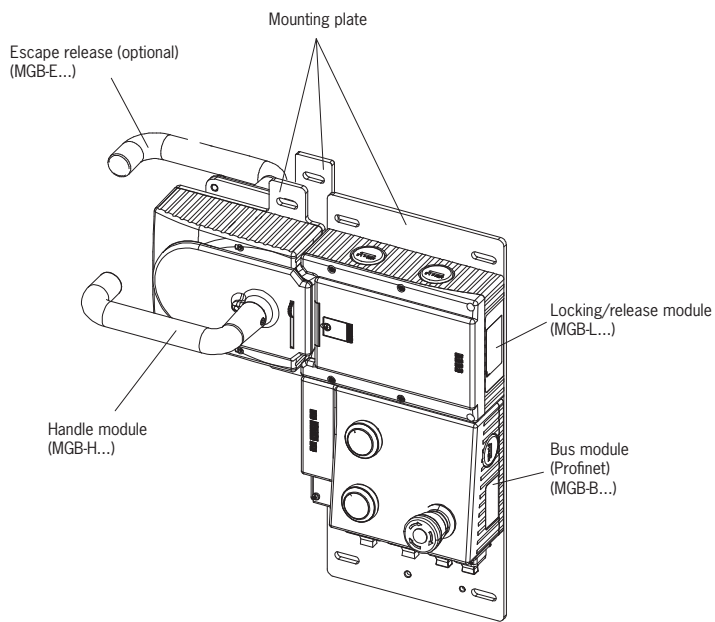

Figure 1: Components at a glance



NOTICE

MGB-PN systems are completely factory configured. The configuration must not be changed subsequently. The illustrations in this chapter can deviate from your system and serve only as examples. The configuration of your MGB system can be found in the data sheet included with every MGB system.

7.1. Bus module MGB-B-...-PN

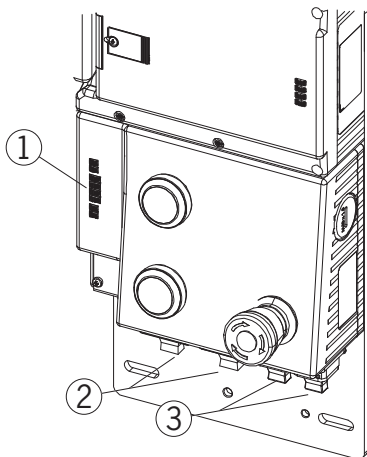

Key:

- ① LED indicator
- ② Power supply
- ③ PROFINET connection

Notice:

Depending on version, additional controls and indicators may be integrated into the cover. See enclosed data sheet.

Figure 2: Bus module MGB-B-...-PN (configuration example)

7.2. Locking/release module MGB-L.-

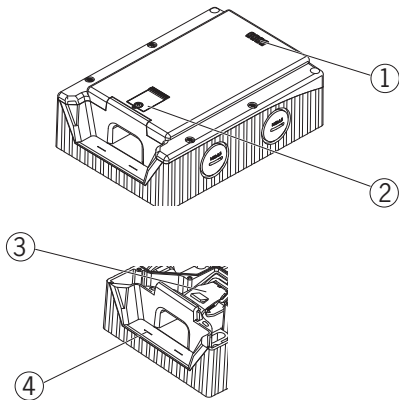

Key:

- ① LED indicator
- ② Cover for auxiliary release
- ③ Locking arm (only version with guard locking)
- ④ Auxiliary marking for max. permitted mounting distance

Notice:

Depending on version, additional controls and indicators may be integrated into the cover. See enclosed data sheet.

Figure 3: Locking/release module MGB-L.-

7.3. Handle module MGB-H...

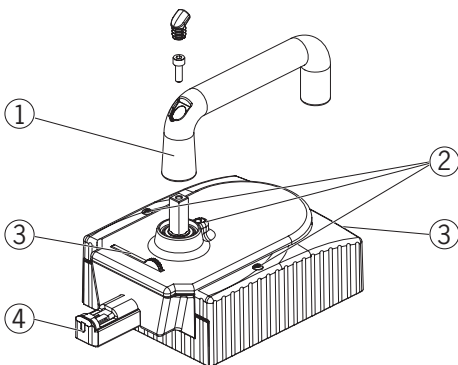

Key:

- ① Door handle
- ② Locking screws T10 for housing cover and handle adjustment
- ③ Fold-out lockout mechanism
(optional: second, automatically extending lockout mechanism)
- ④ Bolt tongue

Notice:

Depending on version, a mounting plate can be included. See enclosed data sheet.

Figure 4: Handle module MGB-H...

7.4. Escape release MGB-E... (optional)

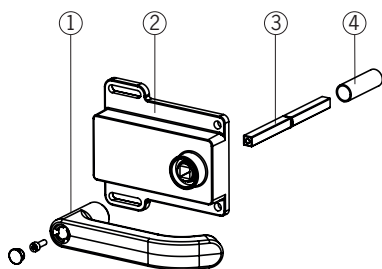

Key:

- ① Door handle
- ② Housing
- ③ Actuation axis 8 x 8 mm
(different lengths available)
- ④ Protective sleeve

Notice:

Depending on version, a mounting plate can be included. See enclosed data sheet.

Figure 5: Escape release MGB-E...

7.5. Dimension drawing

See enclosed data sheet.

8. Manual release

Some situations require the guard locking to be released manually (e.g. malfunctions or an emergency). A function test should be performed after release.

More information on this topic can be found in the standard EN ISO 14119:2013, section 5.7.5.1. The device can feature the following release functions:

8.1. Auxiliary release

In the event of servicing, the guard locking can be released with the auxiliary release irrespective of the state of the solenoid (see Figure 6).



Important!

- › The system enters into a latching fault when the auxiliary release is actuated. See *System status table, signal sequence incorrect* status (DIA red, Lock flashes 1 time).
- › The system might not enter into a latching fault if the auxiliary release is actuated very slowly.
- › The auxiliary release is not a safety function.
- › The machine manufacturer must select and use a suitable release (escape release, emergency release, etc.) for a specific application. A hazard assessment is required for this purpose. It may be necessary to take specifications from a product standard into account.
- › The correct function must be checked at regular intervals.
- › Loss of the release function due to mounting errors or damage during mounting. Check the release function every time after mounting.
- › Observe the notes on any enclosed data sheets.

The locking screw must be screwed back in and sealed (with sealing lacquer, for example) after mounting and after every use of the auxiliary release. Tightening torque 0.5 Nm.

1. Undo locking screw.
2. Lift locking arm using a screwdriver and actuate door handle.

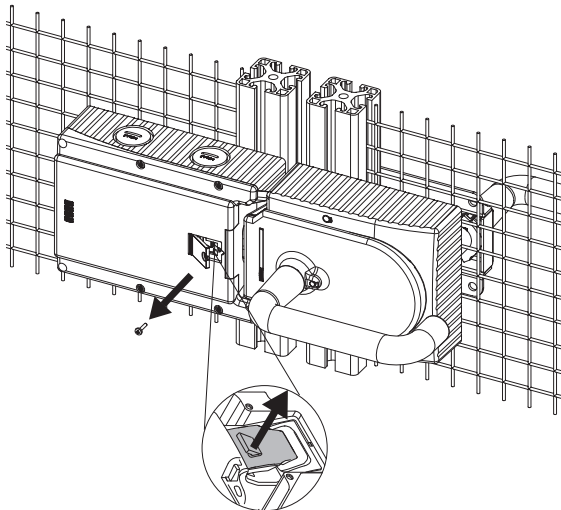

Figure 6: Auxiliary release

8.2. Lockout mechanism

If the lockout mechanism is pivoted out/extended, the bolt tongue cannot be extended. The lockout mechanism can be secured with padlocks (see *Figure 7*). This is intended to prevent people from being locked in unintentionally. The lockout mechanism does not fulfill any safety function.

➔ To pivot out, press the grooved part (possible only with bolt tongue retracted).

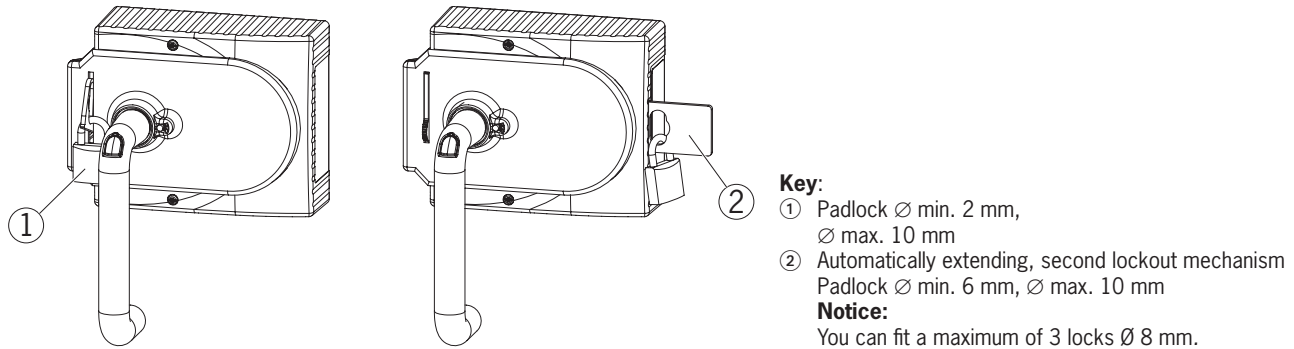

Figure 7: Lockout mechanism secured with padlock

8.3. Escape release (optional)

The escape release is used to open a locked guard from the inside without tools.

The system enters into a latching fault when the escape release is actuated.

See chapter 17. *System status table on page 39, signal sequence incorrect status (DIA red, Lock flashes 1 time).*

The system might not enter into a latching fault if the escape release is actuated very slowly.



Important!

- › It must be possible to actuate the escape release manually from inside the protected area without tools.
- › It must not be possible to reach the escape release from the outside.
- › The actuator must not be under tensile stress during manual release.
- › The escape release meets the requirements of Category B according to EN ISO 13849-1:2008.
- › The correct function must be checked at regular intervals.
- › Observe the notes on any enclosed data sheets.

- › Fit escape release such that operation, inspection and service are possible.
- › The actuation axis for the escape release must be inserted min. 10 mm into the handle module. Note the information on the different profile widths in the chapter 8.3.1. *Preparing escape release on page 19.*
- › Adjust escape release axis at right angles to the handle module. See *Figure 8.*

8.3.1. Preparing escape release

Profile width D	Length required for actuation axis		Which EUCHNER parts are required?	Necessary work steps
	Without mounting plates	With mounting plates (4 mm each)		
	D+9	D+17		
30 mm	39 mm	47 mm	Standard escape release with 107 mm axis (order no. 100465)	Shorten to required length
40 mm	49 mm	57 mm	Standard escape release with 107 mm axis (order no. 100465) If necessary, extended actuation axis (order no. 106761)	<i>Without mounting plates:</i> none <i>With mounting plates:</i> Use extended actuation axis and protective sleeve and shorten to required length
45 mm	54 mm	62 mm	Standard escape release with 107 mm axis (order no. 100465) and extended actuation axis (order no. 106761)	Use extended actuation axis and protective sleeve and shorten to required length
50 mm	59 mm	67 mm	Standard escape release with 107 mm axis (order no. 100465) and extended actuation axis (order no. 106761)	Use extended actuation axis and protective sleeve and shorten to required length

Example without mounting plates:

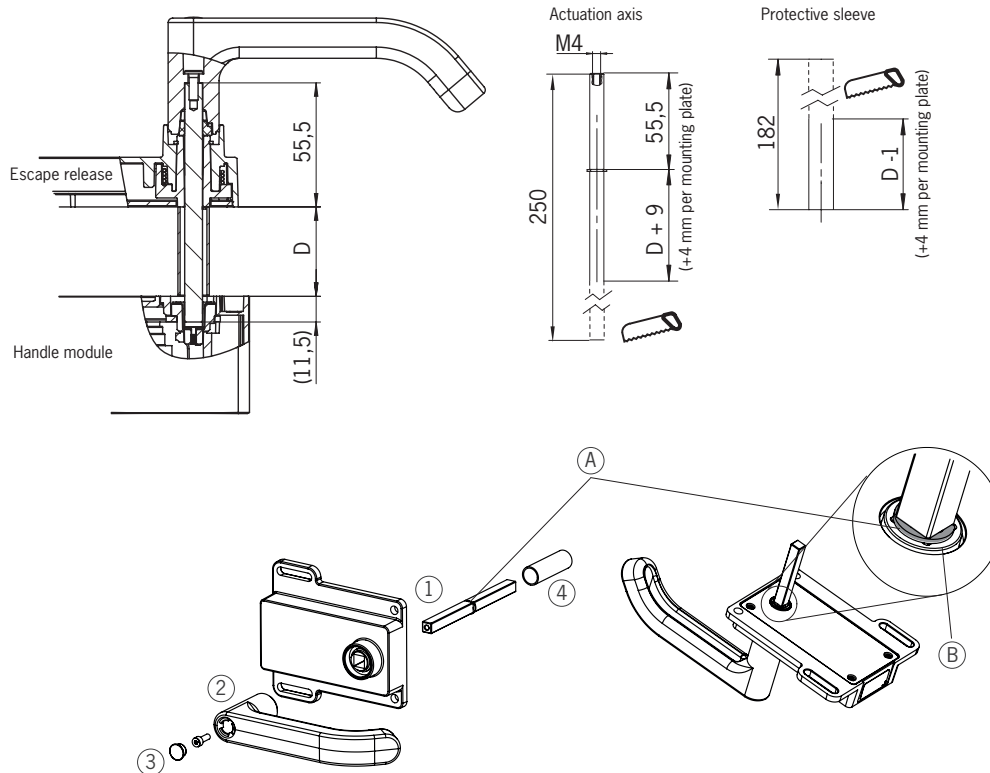

- ① Insert actuation axis. The snap ring **A** must be in contact with the escape release **B**.
- ② Fit door handle.
- ③ Tighten fixing screw to 2 Nm and push in cap.
- ④ Fit protective sleeve.

Figure 8: Preparing escape release

9. Mounting



WARNING

Mounting must be performed only by authorized personnel.

With two-leaf hinged doors, one of the two door leaves must also be latched mechanically.

Use a rod latch (Item) or a double-door lock (Bosch Rexroth) for this purpose, for example.



Important!

› In case of flush installation, the operating distances change as a function of the installation depth and the guard material.

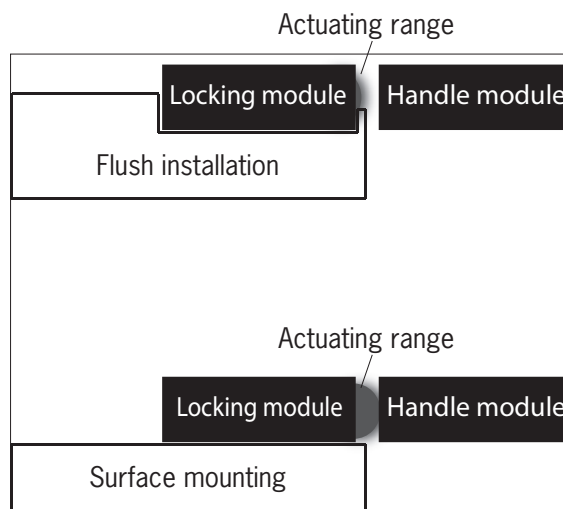

Tip!

- › You will find an animation on the mounting process at www.mgb.euchner.com.
- › The color and labeling of pushbuttons and indicators can be modified.

For mounting steps, see *Figure 9* and *Figure 10* to *Figure 15*.

Attach system such that operation of the auxiliary release as well as inspection and service are possible.

The locking screw of the auxiliary release must be returned to its original position and sealed before putting into operation (with sealing lacquer, for example).

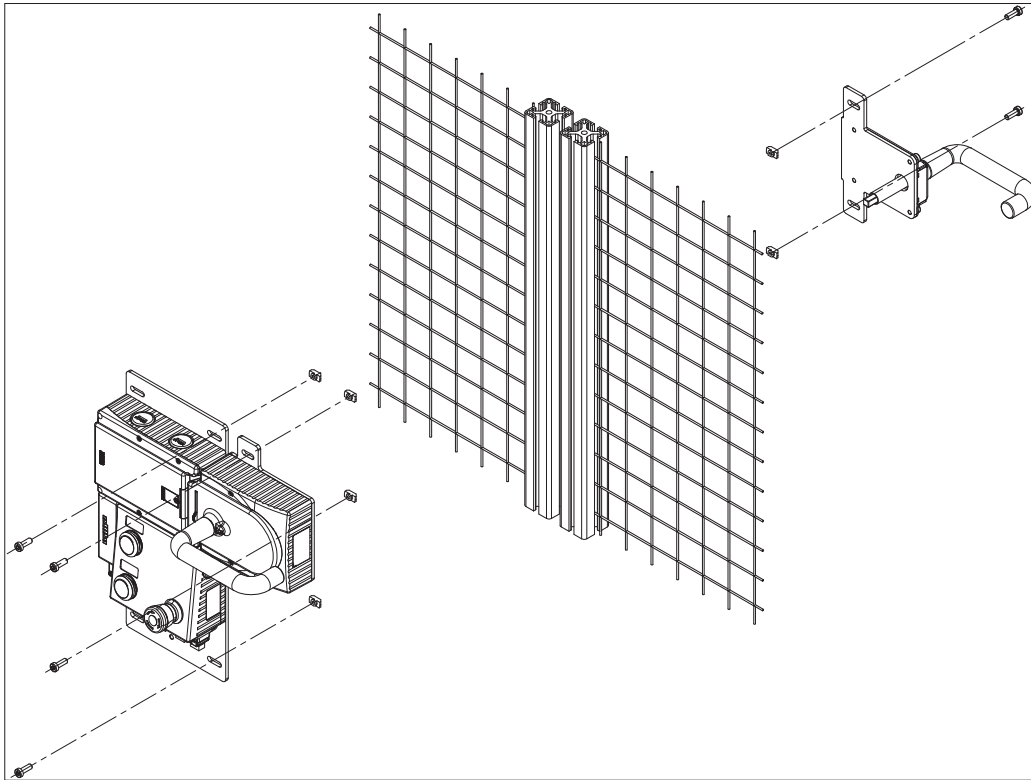
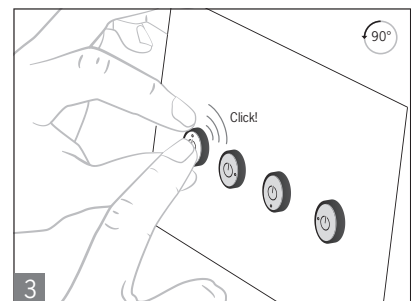
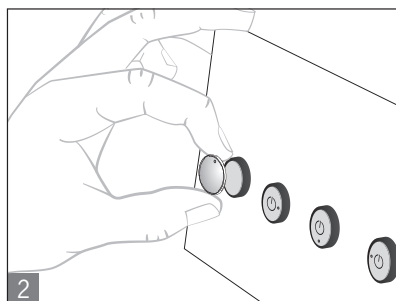
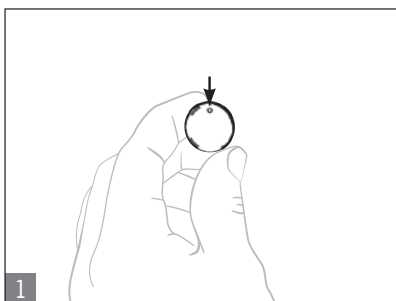

Figure 9: Installation example for door hinged on the right (general view)

9.1. Mounting lens

Mounting



Removal

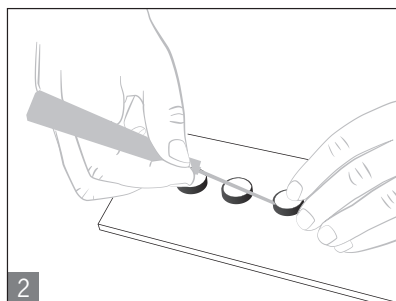
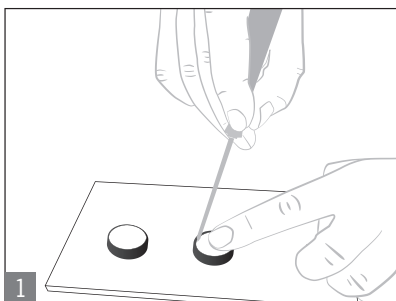

10. Changing actuating direction

(here: from right to left)



Important!

It is possible to make this change only when the bolt tongue is not extended and an escape release is not yet mounted.

As supplied, the handle module is set either for doors hinged on the right or for doors hinged on the left.

Based on the example of a handle module for doors hinged on the right this means:

- The guard opens by pressing down the door handle.
- The system is mounted the other way around for doors hinged on the left. In other words, the guard opens by pressing up the door handle (see *Figure 10*). For this reason, the actuating direction of the door handle must be changed (see *Figure 10* to *Figure 15*).

(Similarly on handle modules for doors hinged on the left)

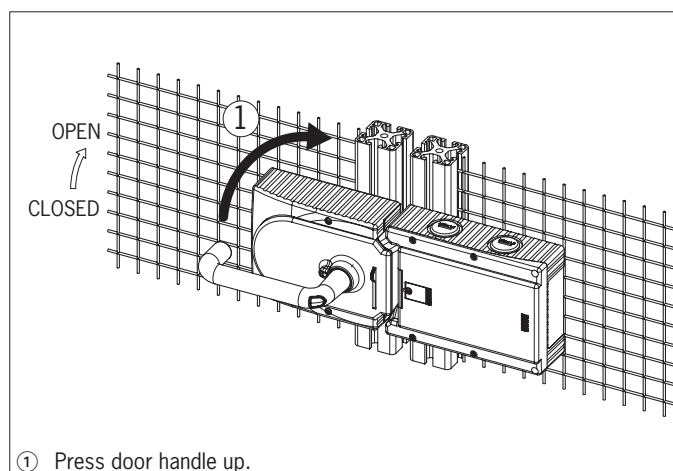

① Press door handle up.

Figure 10: Changing actuating direction, step ①

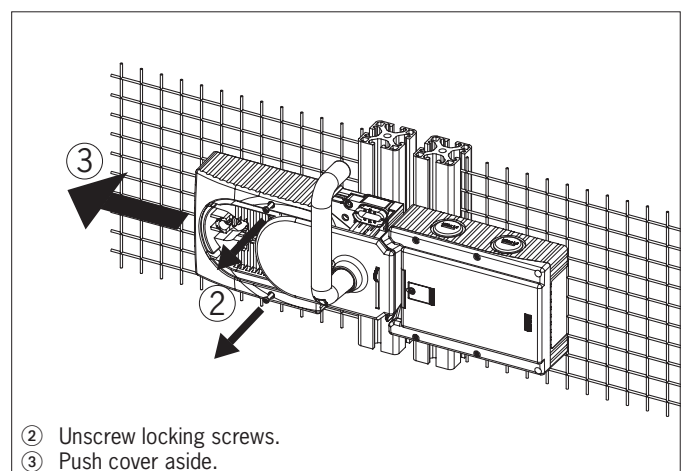

② Unscrew locking screws.
③ Push cover aside.

Figure 11: Changing actuating direction, steps ② and ③

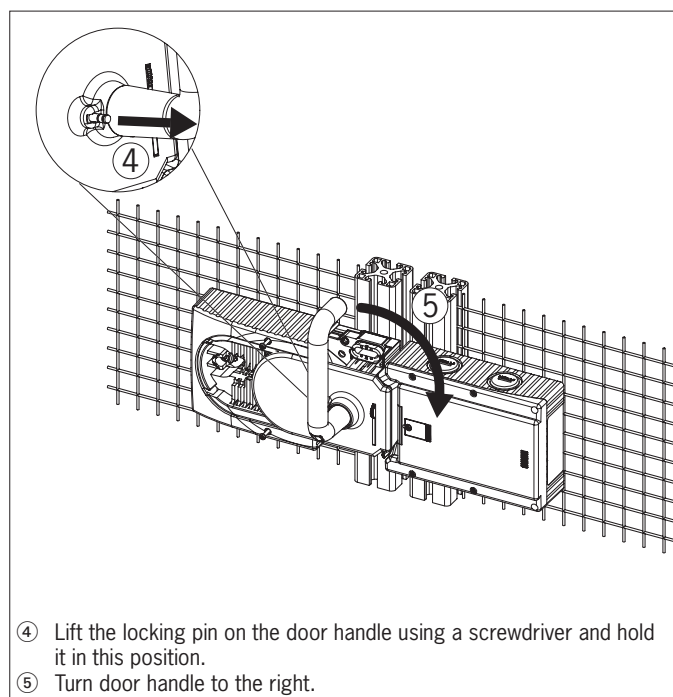

④ Lift the locking pin on the door handle using a screwdriver and hold it in this position.
⑤ Turn door handle to the right.

Figure 12: Changing actuating direction, steps ④ and ⑤

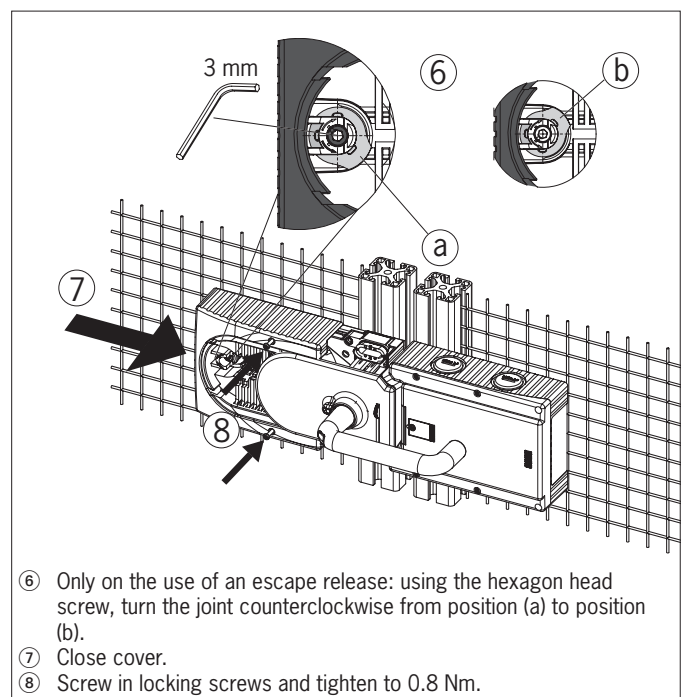

⑥ Only on the use of an escape release: using the hexagon head screw, turn the joint counterclockwise from position (a) to position (b).
⑦ Close cover.
⑧ Screw in locking screws and tighten to 0.8 Nm.

Figure 13: Changing actuating direction, steps ⑥ to ⑧

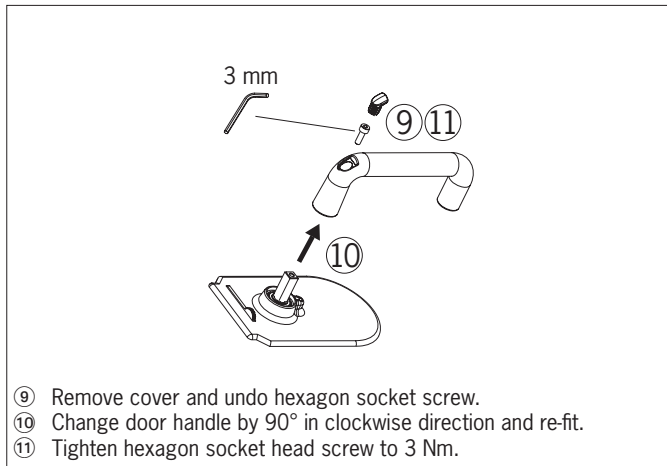

Figure 14: Changing actuating direction, steps ⑨ to ⑪

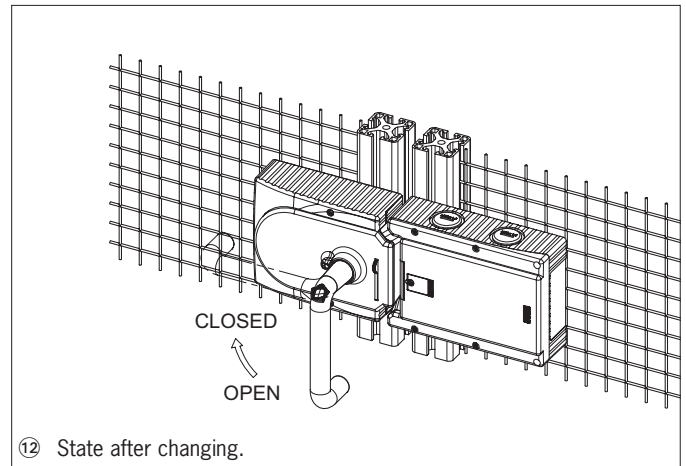

Figure 15: Changing actuating direction, final state

11. Protection against environmental effects

Lasting and correct safety function requires that the system must be protected against foreign bodies such as swarf, sand, blasting shot, etc., which can become lodged in the locking and handle modules. For this purpose a suitable installation position should be selected.

Cover device during painting work!

12. Controls and indicators

LEDs on the bus module

LED	Color	Description
Link 1 and Link 2	green	Bus connector inserted: statically on
Data 1 and Data 2	yellow	Data transfer: flashing
SF	red	System error: statically on (see chapter on diagnostic messages of the MGB system)
BF	red	Bus error: statically on (see chapter on diagnostic messages of the MGB system)
ON	green	Self-test OK: statically on Device passivated: flashing
UB	green	Power supply OK: statically on

Binary coding of the DIP switches for PROFI-safe address (factory setting: 135)

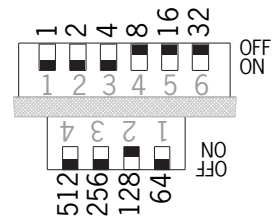

default address:
 $128 + 4 + 2 + 1 = 135$

LEDs on locking/release module

see System status table

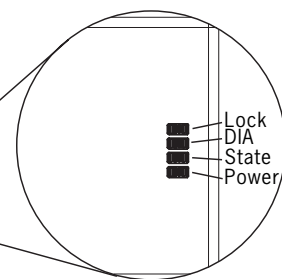

Cover for DIP switches

DIP switches for PROFI-safe address

For coding, see above

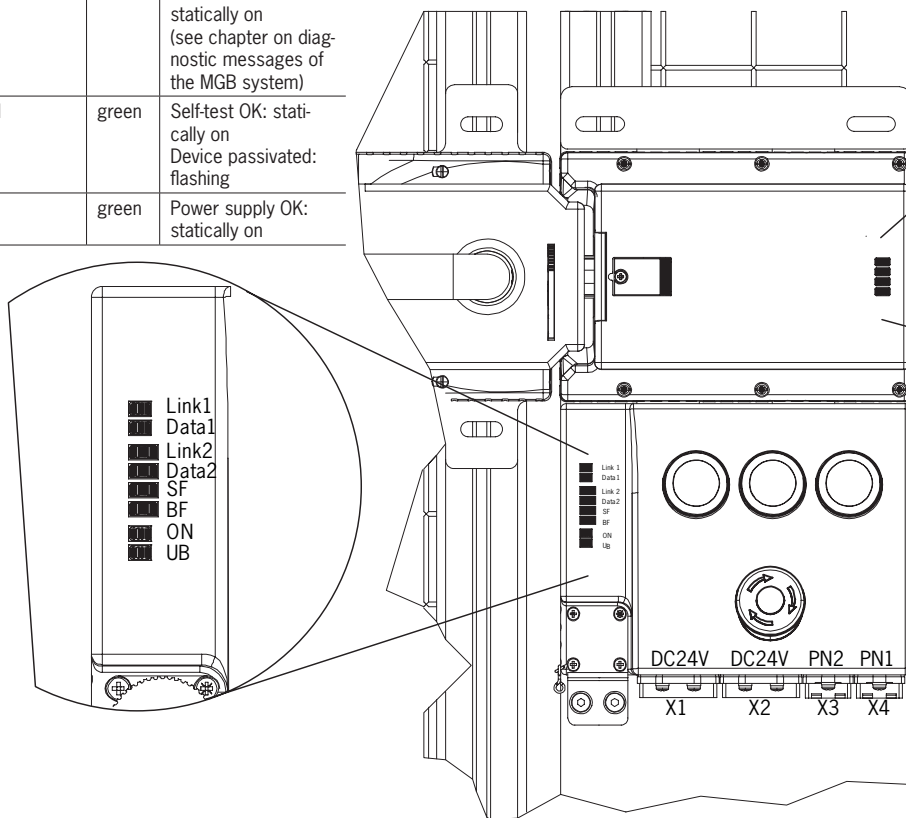
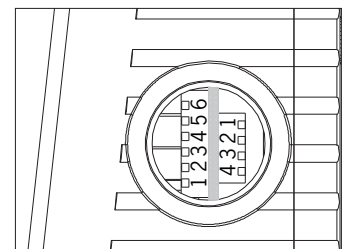

Figure 16: Indicators and controls/binary coding of the DIP switches for PROFI-safe address (factory setting: 135)

13. Electrical connection

	<p>WARNING</p> <p>In the event of a fault, loss of the safety function due to incorrect connection.</p> <ul style="list-style-type: none"> › Mounting must be performed only by authorized personnel. › Lay the connecting cables with protection to prevent the risk of short circuits.
	<p>CAUTION</p> <p>Risk of damage to equipment or malfunctions as a result of incorrect connection.</p> <ul style="list-style-type: none"> › All the electrical connections must either be isolated from the mains supply by a safety transformer according to EN IEC 61558-2-6 with limited output voltage in the event of a fault, or by other equivalent insulation measures. › Power devices which are a powerful source of interference must be installed in a separate location away from the input and output circuits for signal processing. The cable routing for safety circuits should be as far away as possible from the cables of the power circuits. › In order to avoid EMC interference, follow the EMC notes on devices in the immediate vicinity of the MGB system and its cables. › In order to avoid EMC interference, the physical environmental and operating conditions at the installation site of the device must comply with the requirements according to the standard DIN EN 60204-1:2006, section 4.4.2/EMC). › The functional earth \oplus must be connected. An M6 thread hole is available on the mounting plate for this purpose.
	<p>Important!</p> <ul style="list-style-type: none"> › The supply for further devices on the bus may be forwarded via the Euchner MGB system. The entire supply current through the MGB must not be higher than specified in chapter 18. <i>Technical data on page 40.</i> › If the device does not appear to function when operating voltage is applied (e.g. UB LED does not illuminate), the safety system must be returned unopened to the manufacturer. › To ensure the stated degree of protection is achieved, the cover screws must be tightened to a tightening torque of 1 Nm. › Tighten screw for the cover for the auxiliary release to 0.5 Nm.

13.1. Notes about

	<p>Important!</p> <ul style="list-style-type: none"> › This device is intended to be used with a Class 2 power source in accordance with UL1310 ¹⁾. As an alternative an LV/C (Limited Voltage/Current) power source with the following properties can be used: <ul style="list-style-type: none"> - This device shall be used with a suitable isolating source in conjunction with a fuse in accordance with UL248. The fuse shall be rated max. 3.3 A and be installed in the max. 30 V DC power supply to the device in order to limit the available current to comply with the UL requirements. Please note possibly lower connection ratings for your device (refer to the technical data). <p><small>1) Note on the scope of UL approval: only for applications as per NFPA 79 (Industrial Machinery). The devices have been tested as per the requirements of UL508 (protection against electric shock and fire).</small></p>
--	---------------------------------------------------------------------------------------------------------------------------------------------------------------------------------------------------------------------------------------------------------------------------------------------------------------------------------------------------------------------------------------------------------------------------------------------------------------------------------------------------------------------------------------------------------------------------------------------------------------------------------------------------------------------------------------------------------------------------------------------------------------------------------------------------------------------------------------------------------------------------------------------------------------------------------------------------------------------------------------------------

13.2. Connections on the bus module

The bus module includes the PROFINET connections (X3 and X4) and the power supply connections (X1 and X2). Depending on version, connection is made via push-pull plugs according to IEC 61076-3-117, variant 14, or 7/8" plugs according to ANSI/B93.55M-1981 and M12 plugs (d-coded) according to IEC 61076-3-101.

The bus module includes a PROFINET RT switch for Ethernet connection.

13.2.1. Terminal assignment for version with push-pull plugs

Pin	Description
X1.1	L1 operating voltage DC 24 V
X1.2	N1 operating voltage 0 V
X1.3	L2 auxiliary voltage* DC 24 V
X1.4	N2 auxiliary voltage* 0 V
X1.5	Functional earth

* The auxiliary voltage is not required for the MGB system

Pin	Description
X2.1	L1 operating voltage DC 24 V
X2.2	N1 operating voltage 0 V
X2.3	L2 auxiliary voltage* DC 24 V
X2.4	N2 auxiliary voltage* 0 V
X2.5	Functional earth

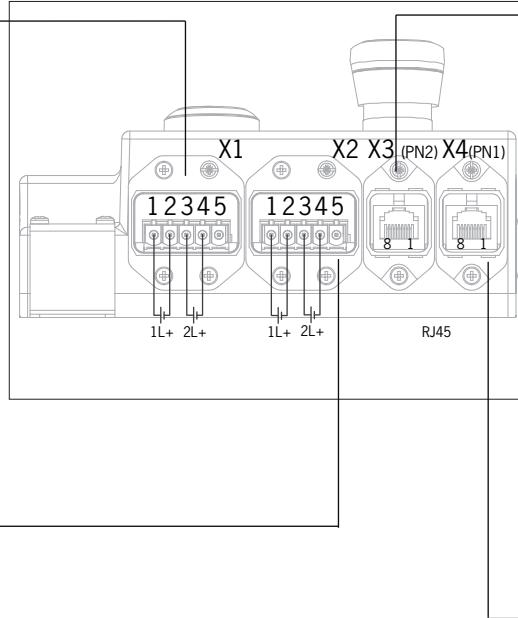

Pin	Description
X3.1	Receive Data RD+
X3.2	Receive Data RD-
X3.3	Transmit Data TD+
X3.4	n.c.
X3.5	n.c.
X3.6	Transmit Data TD-
X3.7	n.c.
X3.8	n.c.

Pin	Description
X4.1	Receive Data RD+
X4.2	Receive Data RD-
X4.3	Transmit Data TD+
X4.4	n.c.
X4.5	n.c.
X4.6	Transmit Data TD-
X4.7	n.c.
X4.8	n.c.

13.2.2. Terminal assignment for version with 7/8" and M12 plugs, d-coded

Pin	Description
X1.1	N2 auxiliary voltage *0 V
X1.2	N1 operating voltage 0 V
X1.3	Functional earth
X1.4	L1 operating voltage DC 24 V
X1.5	L2 auxiliary voltage* DC 24 V

* The auxiliary voltage is not required for the MGB system

Pin	Description
X2.1	N2 auxiliary voltage *0 V
X2.2	N1 operating voltage 0 V
X2.3	Functional earth
X2.4	L1 operating voltage DC 24 V
X2.5	L2 auxiliary voltage* DC 24 V

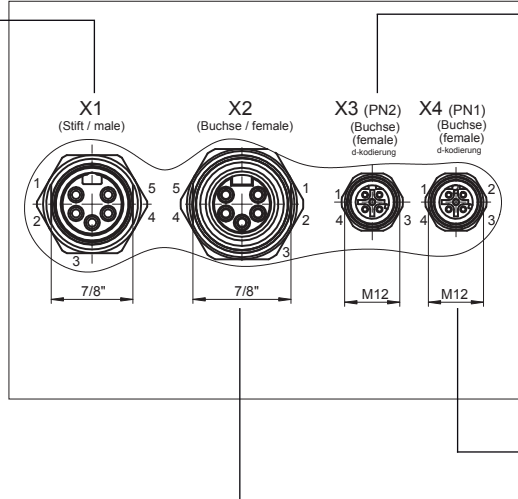



Pin	Description
X3.1	Transmit Data +TD
X3.2	Receive Data +RD
X3.3	Transmit Data -TD_N
X3.4	Receive Data -RD_N
Functional earth on plug housing	

Pin	Description
X4.1	Transmit Data +TD
X4.2	Receive Data +RD
X4.3	Transmit Data -TD_N
X4.4	Receive Data -RD_N
Functional earth on plug housing	

14. Setup

14.1. Integrating into PROFINET and PROFIsafe

	<p>NOTICE</p> <p>The parameters <i>Update time</i> and <i>F-WD-Time</i> have a decisive effect on the reaction time of the safety function. The safety function could be lost if the reaction times are too long.</p>
	<p>Important!</p> <p>You will require the corresponding GSD file in GSDML format in order to integrate the MGB system: ▶ GSDML-Vx.x-Euchner-MGB-PN_D_110026-YYYYMMDD.xml You will find the GSD file in the Download area at www.euchner.com. Prior to setup, the GSD file must be imported into the configuration software for the control system (see control system manual).</p>

You must perform the following steps to integrate the MGB system into PROFINET:

1. Configure the MGB system with the configuration software of the control system and assign parameters.

The following PROFINET parameters must be set:

- ▶ Device name (factory setting from GSD file): [euchnermgb].
- ▶ IP address: optionally fixed or dynamic
- ▶ Update time:
 Recommendation [32 ms]
 Maximum value [128 ms]
 (with number of repeat cycles = 3)

The following PROFIsafe parameters must be set:

- ▶ F_dest_adr (PROFIsafe address): this is generally assigned automatically by the control system.
 - ▶ F_WD_Time (time during which the control system expects a response from the PROFIsafe device): [xxx ms]. Factory setting from GSD file: [600 ms].
2. Set the PROFIsafe address (F_dest_adr) on the MGB system using the DIP switches (see *Figure 16 on page 24*). Important: Identical addresses must be set in the control system and on the device.
 3. Save the configuration and transfer it to the MGB system.

14.2. Replacement of an MGB system without programming device

If servicing is required, the MGB system is easy to replace with a new one. For this purpose, the following prerequisites must be met:

- ▶ The DIP switch settings (PROFIsafe address) on the new device must match those on the old device.
- ▶ Your Profinet master must support the automatic replacement of Profinet devices.
- ▶ Your Profinet topology must be correctly configured.
- ▶ The replacement device must be connected to the same port as its predecessor.
- ▶ There must be no device name in the MGB system.
 This field is empty in the delivery state. Systems that already contain a name must first be reset to the factory settings.

Once these conditions are met, simply replace the old system with the new system.

The Profinet bus does not need to be switched off for this purpose.

14.3. Resetting system to factory settings

You will find detailed instructions in the manual for the configuration software for your control system.

14.4. Teach-in operation (only for MGB unicode)

The handle module must be assigned to the locking module using a teach-in function before the system comprising locking module and handle module forms a functional unit.

The system is in a safe state (bits SI02, SI03, SI04, SI1.0 and SI1.1 are not set) during a teach-in operation.



Important!

- › The locking module disables the code for the previous handle module if teach-in is carried out for a new handle module. Teach-in is not possible again immediately for this device if a new teach-in operation is carried out. The disabled code is deleted in the locking module only after a third code has been taught-in.
- › The locking module can be operated only with the last handle module taught in.
- › If, in the teach-in standby state, the locking module detects the handle module taught-in or a disabled handle module, the teach-in standby state is ended immediately and the locking module changes to normal operation.
- › If the bolt tongue is in the actuating range for less than 60 s, the handle module is not taught in.

Teaching-in handle module

1. Fit handle module.
2. Close safety device. Check for correct alignment and distance using the marking on the locking module and re-adjust if necessary.
3. Insert bolt tongue into the locking module.
4. Apply operating voltage to the locking module.
- ➔ Teach-in operation starts, green LED (State) flashes slowly (approx. 1 Hz). The teach-in standby state is active for 3 minutes after switch on. During the teach-in operation, the locking module checks whether the handle module is a disabled handle module. Provided this is not the case, the teach-in operation is completed after approx. 60 seconds, and the green LED (State) goes out. The new code has now been stored, and the old code is disabled.
5. Reset via bit 00.1 in the data block of the diagnostic function to activate the taught-in code of the handle module in the locking module or by switching the operating voltage off and on.

14.5. Mechanical function test

It must be possible to insert the bolt tongue easily into the locking module. To check, close guard several times and actuate door handle.

If available, check function of the escape release. With active guard locking, it must be possible to operate the escape release from the inside without excessive effort (approx. 40 N).

14.6. Electrical function test

1. Switch the operating voltage on or perform a reset via output bit 00.1 in the data block of the diagnostic function.
2. Close all guards and insert the bolt tongue into the locking module.
In case of guard locking by solenoid force ➔ activate guard locking.
 - › The machine must not start automatically.
 - › It must not be possible to open the guard.
 - › **The following applies to MGB-LO:** The green LED (State) is illuminated.
 - › **The following applies to MGB-L1/2:** The green LED (State) and the yellow LED (Lock) are illuminated.
3. Enable operation in the control system.
 - › It must not be possible to deactivate guard locking as long as operation is enabled.
4. Disable operation in the control system and deactivate guard locking.
 - › The guard must remain locked until there is no longer any risk of injury.
 - › It must not be possible to start the machine as long as guard locking is deactivated.
 - › It must be possible to open the guard.

Repeat steps 2-4 for each guard.

14.7. PROFINET data bytes (data blocks for non-safe functions)

The following modules can be present in various combinations in an MGB system:

- › Bus module, MGB-B-...PN (contains everything required for the PROFINET connection)
- › Locking module, MGB-L. (forms the door locking mechanism together with the handle module)
- › Control module, MGB-C. (includes various controls/indicators)

Each MGB module occupies a certain number of PROFINET data bytes in the input and output areas of the control system.

The PROFINET data bytes for every MGB module or also individual functions are combined in data blocks (see tables below).

A distinction is made between the following data block types:

- › Data blocks for MGB modules
- › Data blocks for individual functions

These data blocks are automatically assigned to the designated slots in the configuration software of the control system when your MGB system is placed. This assignment changes according to MGB system. The exact assignment of the slots and the exact bit allocation for your device can be seen in the data sheet. The data sheet is included with every MGB system.

14.8. Data blocks for MGB modules

All standard functions of an MGB module are combined in these data blocks. Additional functions, e.g. an optional enabling switch or a stacklight, have separate data areas (see chapter 14.9. *Data blocks of individual functions at a glance on page 32*).

14.8.1. Data block for MGB bus module

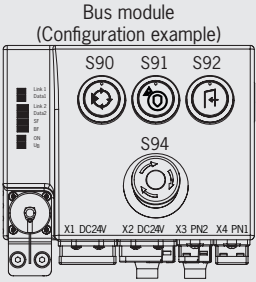
MGB module	Slot	Required memory in data area of the control system (IO controller) (Refer to the data sheet of your device for the exact bit allocation)									
 <p>Bus module (Configuration example)</p>	See data sheet for slot assignment	Input area (2 bytes)	Control element	-	-	S95	S94	S93	S92	S91	S90
			Bit	I0.7	I0.6	I0.5	I0.4	I0.3	I0.2	I0.1	I0.0
		Output area (1 byte)		Display	H97	H96	H95	H94	H93	H92	H91
			Bit	O0.7	O0.6	O0.5	O0.4	O0.3	O0.2	O0.1	O0.0

Bit allocation for 1st byte					
Input area	Bit	Description	Output area	Bit	Description
	I0.0	Depends on your configuration variant (refer to the data sheet of your device for the exact bit allocation)			O0.0
I0.1					
I0.2					
I0.3					
I0.4					
I0.5					
I0.6					
I0.7					
Bit allocation for 2nd byte					
Input area	Bit	Description			
	I1.0	Depends on your configuration variant (refer to the data sheet of your device for the exact bit allocation)			
	I1.1				
	I1.2				
	I1.3				
	I1.4				
	I1.5				
	I1.6				
I1.7					

14.8.2. Data block for MGB locking module L0, L1 or L2

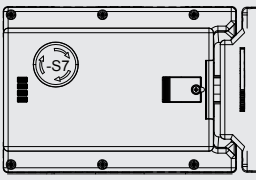
MGB module	Slot	Required memory in data area of the control system (IO controller) (Refer to the data sheet of your device for the exact bit allocation)									
Locking module (Configuration example) 	See data sheet for slot assignment	Input area (1 byte)	Control element	ÜK	SK	-	-	-	Z	R	T
			Bit	I0.7	I0.6	I0.5	I0.4	I0.3	I0.2	I0.1	I0.0
		Output area (1 byte)	Display	-	-	-	-	-	-	-	Guard locking solenoid
			Bit	O0.7	O0.6	O0.5	O0.4	O0.3	O0.2	O0.1	O0.0

Bit allocation					
Input area	Bit	Description	Output area	Bit	Description
	I0.0	T (door position)		O0.0	Guard locking solenoid – control voltage on (function identical to bit S00.0 => but control from PROFINET area)
	I0.1	R (bolt position)		O0.1	n.c.
	I0.2	Z (guard locking)		O0.2	n.c.
	I0.3	n.c.		O0.3	n.c.
	I0.4	n.c.		O0.4	n.c.
	I0.5	n.c.		O0.5	n.c.
	I0.6	SK (T AND R)		O0.6	n.c.
I0.7	ÜK (T AND R AND Z)	O0.7	n.c.		

14.8.3. Data block for MGB control module

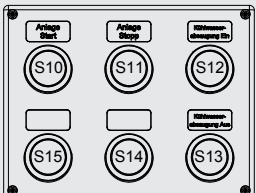
MGB module	Slot	Required memory in data area of the control system (IO controller) (Refer to the data sheet of your device for the exact bit allocation)									
Control module (Configuration example) 	See data sheet for slot assignment	Input area (2 bytes)	Control element	S17	S16	S15	S14	S13	S12	S11	S10
			Bit	I0.7	I0.6	I0.5	I0.4	I0.3	I0.2	I0.1	I0.0
		Output area (1 byte)	Display	H17	H16	H15	H14	H13	H12	H11	H10
			Bit	O0.7	O0.6	O0.5	O0.4	O0.3	O0.2	O0.1	O0.0

Bit allocation for 1st byte					
Input area	Bit	Description	Output area	Bit	Description
	I0.0	Depends on your configuration variant (refer to the data sheet of your device for the exact bit allocation)		O0.0	Depends on your configuration variant (refer to the data sheet of your device for the exact bit allocation)
	I0.1			O0.1	
	I0.2			O0.2	
	I0.3			O0.3	
	I0.4			O0.4	
	I0.5			O0.5	
	I0.6			O0.6	
I0.7	O0.7				

Bit allocation for 2nd byte					
Input area	Bit	Description			
	I1.0	Depends on your configuration variant (refer to the data sheet of your device for the exact bit allocation)			
	I1.1				
	I1.2				
	I1.3				
	I1.4				
	I1.5				
	I1.6				
I1.7					

14.9. Data blocks of individual functions at a glance

Function data blocks are required for all additional functions that are not included in the data blocks for MGB modules.

14.9.1. Data block for signal stack module function (optional)

If your MGB system includes this function, the interface to the signal stack module is usually plug connector X6. The following table shows which bit is assigned to which pin of X6. Please refer to the data sheet for any deviations from this.

Function	Slot	Required memory in data area of the control system (IO controller) (Refer to the data sheet of your device for the exact bit allocation)								
Signal stack module	See data sheet for slot assignment	Pin	-	-	-	X6.8	X6.6	X6.5	X6.2	X6.7
		Output area (1 byte)	Bit	00.7	00.6	00.5	00.4	00.3	00.2	00.1

Bit allocation		
Output area	Bit	Description
	00.0	Pin 7 on plug connector X6
	00.1	Pin 2 on plug connector X6
	00.2	Pin 5 on plug connector X6
	00.3	Pin 6 on plug connector X6
	00.4	Pin 8 on plug connector X6
	00.5	n.c.
	00.6	n.c.
	00.7	n.c.

14.9.2. Data block for emergency stop function (optional)

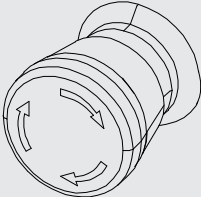
Function	Slot	Required memory in data area of the control system (IO controller) (Refer to the data sheet of your device for the exact bit allocation)										
Emergency stop 	See data sheet for slot assignment	Input area (1 byte)	Switching element	-	-	-	-	-	-	-	Monitoring contact	
			Bit	I0.7	I0.6	I0.5	I0.4	I0.3	I0.2	I0.1	I0.0	
		Output area (1 byte)	Display	-	-	-	-	-	-	-	-	LED (optional)
			Bit	00.7	00.6	00.5	00.4	00.3	00.2	00.1	00.0	

Bit allocation					
Input area	Bit	Description	Output area	Bit	Description
	I0.0	Emergency stop monitoring contact		00.0	Emergency stop illumination (optional)
	I0.1	n.c.		00.1	n.c.
	I0.2	n.c.		00.2	n.c.
	I0.3	n.c.		00.3	n.c.
	I0.4	n.c.		00.4	n.c.
	I0.5	n.c.		00.5	n.c.
	I0.6	n.c.		00.6	n.c.
I0.7	n.c.	00.7	n.c.		

14.9.3. Data block for enabling switch function (optional)

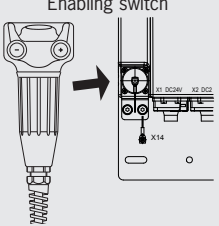
Function	Slot	Required memory in data area of the control system (IO controller) (Refer to the data sheet of your device for the exact bit allocation)									
Enabling switch 	See data sheet for slot assignment	Input area (1 byte)	Function	Holder	+ button	- button	-	-	-	-	Enabling
			Bit	I0.7	I0.6	I0.5	I0.4	I0.3	I0.2	I0.1	I0.0
		Output area (1 byte)	Display	-	-	-	-	-	-	- button LED	+ button LED
			Bit	O0.7	O0.6	O0.5	O0.4	O0.3	O0.2	O0.1	O0.0

Bit allocation					
Input area	Bit	Description	Output area	Bit	Description
	I0.0	Enabling switch in "enabling" position (monitoring contact)		O0.0	Enabling switch illumination for + button
	I0.1	n.c.		O0.1	Enabling switch illumination for - button
	I0.2	n.c.		O0.2	n.c.
	I0.3	n.c.		O0.3	n.c.
	I0.4	n.c.		O0.4	n.c.
	I0.5	Enabling switch + button		O0.5	n.c.
	I0.6	Enabling switch - button		O0.6	n.c.
I0.7	Enabling switch holder detection	O0.7	n.c.		

14.9.4. Data block for operating mode selector function (optional)

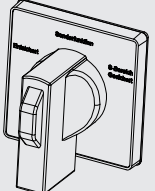
Function	Slot	Required memory in data area of the control system (IO controller) (Refer to the data sheet of your device for the exact bit allocation)									
Operating mode selector 	See data sheet for slot assignment	Input area (1 byte)	Switch (coding 2 of 3)	-	-	-	-	-	-	S91	
			Bit	I0.7	I0.6	I0.5	I0.4	I0.3	I0.2	I0.1	I0.0
		Output area (1 byte)	Display	-	-	-	-	-	-	-	-
			Bit	O0.7	O0.6	O0.5	O0.4	O0.3	O0.2	O0.1	O0.0

Bit allocation					
Input area	Bit	Description	Output area	Bit	Description
	I0.0	Operating mode selector bit 1		O0.0	n.c.
	I0.1	Operating mode selector bit 2		O0.1	n.c.
	I0.2	Operating mode selector bit 3		O0.2	n.c.
	I0.3	n.c.		O0.3	n.c.
	I0.4	n.c.		O0.4	n.c.
	I0.5	n.c.		O0.5	n.c.
	I0.6	n.c.		O0.6	n.c.
I0.7	n.c.	O0.7	n.c.		

14.9.5. Data block for diagnostic function

Function	Slot	Required memory in data area of the control system (IO controller) (see below for exact bit allocation)									
Diagnostics	See data sheet for slot assignment	Input area (1 byte)	Message	-	-	272(6) 273(6)	272(3) 272(4) 272(5)	272(2) 273(2)	272(1) 273(1)	274(4)	Fault
			Bit	I0.7	I0.6	I0.5	I0.4	I0.3	I0.2	I0.1	I0.0
		Output area (1 byte)	Acknowledgment	-	-	-	-	-	-	Reset MGB	Ac- knowl- edg- ment
			Bit	O0.7	O0.6	O0.5	O0.4	O0.3	O0.2	O0.1	O0.0

Bit allocation				
	Input area		Output area	
	Bit	Description	Bit	Description
Input area	I0.0	Device diagnostics: message present. Diagnostic code: see table <i>Device-specific diagnostic information</i> , see Page 37 f.	O0.0	Device diagnostics: acknowledge message, acknowledgment of I0.2, I0.3 or I0.4. I0.0 is also acknowledged if only one message is present
	I0.1	Device diagnostics, device-specific message 274(4) "Plausibility check detected an error (e.g. escape release actuated)"	O0.1	Trigger MGB locking module reset: acknowledge message, acknowledgment of I1. I0 is also acknowledged if only one message is present.
	I0.2	Device diagnostics, device-specific message 272(1) or 273(1) "Error in emergency stop"	O0.2	n.c.
	I0.3	Device diagnostics, device-specific message 272(2) or 273(2) "Error in enabling switch"	O0.3	n.c.
	I0.4	Device diagnostics, device-specific message 272(3,4,5) or 273(3,4,5) "Fault locking module"	O0.4	n.c.
	I0.5	Device diagnostics, device-specific message 272(6) or 273(6) "Error in operating mode selector"	O0.5	n.c.
	I0.6	n.c.	O0.6	n.c.
	I0.7	n.c.	O0.7	n.c.

14.10. PROFIsafe data bytes (data block for safe functions)

Safe PROFIsafe data are transmitted in addition to the non-safe PROFINET data. These data include all information about the door position and guard locking, emergency stop and enabling switch, for example.

The *Standard* PROFIsafe data block includes all safe functions. It is subdivided as follows:

- › 2 input bytes of data for the functions (e.g. emergency stop switch position)
- › 2 additional input bytes (empty)
- › 4 input bytes used within PROFIsafe
- › 1 output byte for the functions (e.g. safe control of guard locking)

All data bits are present in parallel in the non-safe PROFINET data area and can be used as a status bit there.



Important!

Never use the status bits for safety functions!

14.10.1. Data block for PROFIsafe



Important!

Refer to the data sheet enclosed with your MGB system for the exact bit allocation. Use only bits that are specified according to the data sheet.

Function	Slot	Required memory in data area of the control system (IO controller) (see below for exact bit allocation)										
Diagnostics	See data sheet for slot assignment	Input area (6 bytes)		Function	Operating mode selector			Guard locking (Z)	Bolt position (R)	Door position (T)	Enabling switch	Emergency stop
				1st byte	SI0.7	SI0.6	SI0.5	SI0.4	SI0.3	SI0.2	SI0.1	SI0.0
				Function	-	-	-	-	-	-	ÜK	SK
				2nd byte	SI1.7	SI1.6	SI1.5	SI1.4	SI1.3	SI1.2	SI1.1	SI1.0
		Function										
		3rd - 6th bytes		Used within PROFIsafe (control byte, CRC, etc.)								
		Output area (6 bytes)		Function	-	-	-	-	-	-	-	Guard locking
				1st byte	SO0.7	SO0.6	SO0.5	SO0.4	SO0.3	SO0.2	SO0.1	SO0.0
				Function	-	-	-	-	-	-	-	-
				2nd byte	SO1.7	SO1.6	SO1.5	SO1.4	SO1.3	SO1.2	SO1.1	SO1.0
		Function										
		3rd - 6th bytes		Used within PROFIsafe (control byte, CRC, etc.)								

Bit allocation for 1st byte

	Bit	Description		Bit	Description
	Input area	SI0.0		Emergency stop	Output area
SI.01		Enabling switch Enabling contacts closed (three-stage enabling switch in center position), no evaluation of the edges	SO0.1	n.c.	
SI0.2		Door position (T)	SO0.2	n.c.	
SI0.3		Bolt position (R)	SO0.3	n.c.	
SI0.4		Guard locking (Z)	SO0.4	n.c.	
SI0.5		Operating mode selector, 1st bit	SO0.5	n.c.	
SI0.6		Operating mode selector, 2nd bit	SO0.6	n.c.	
SI0.7		Operating mode selector, 3rd bit	SO0.7	n.c.	

Bit allocation for 2nd byte

	Bit	Description		Bit	Description
	Input area	SI1.0		SK (T AND R)	Output area
SI1.1		ÜK (T AND R AND Z)	SO1.1	n.c.	
SI1.2		n.c.	SO1.2	n.c.	
SI1.3		n.c.	SO1.3	n.c.	
SI1.4		n.c.	SO1.4	n.c.	
SI1.5		n.c.	SO1.5	n.c.	
SI1.6		n.c.	SO1.6	n.c.	
SI1.7		Reserved for customer-specific function	SO1.7	n.c.	

15. MGB system diagnostic messages

All diagnostic messages are listed below. The scope of the possible messages can differ depending on MGB system version.

PROFIsafe messages

Display via *BF* LED (see Figure 16)

No.	Description	Measures/rectifying errors
64	Error when comparing the PROFIsafe destination address (F_Dest_Add)	1. Check DIP switch position 2. Restart system
65	Invalid PROFIsafe destination address (F_Dest_Add)	1. Check addressing 2. Restart system
66	Invalid PROFIsafe source address (F_Source_Add)	1. Check addressing 2. Restart system
67	Value for the PROFIsafe time monitoring is 0 ms (F_WD_TIME)	1. Check system times 2. Restart system
68	Parameter F_SIL exceeds SIL of the device-specific application	1. Check settings 2. Restart system
69	Parameter F_CRC_Length does not match the generated values	1. Check settings 2. Restart system
70	Version for F_Parameter not correct	1. Check configuration 2. Restart system
71	Error CRC 1- (during booting)	1. Restart system
72	Device-specific diagnostic information (see following table)	1. Identify error via input bit I0.0 2. For troubleshooting, see the following table with device-specific messages

Device-specific diagnostic information

Display via *SF* LED (see Figure 16)

Discrepancy error (two-channel monitoring detected an error)

Notice:

- ▶ The discrepancy time is the maximum time during which channel 1 and channel 2 may have different signal states.
- ▶ If acknowledgment was unsuccessful, send the device to the manufacturer.

No.	Description	Measures/rectifying errors
272	Discrepancy time exceeded	1. Search for cause 2. Acknowledge fault (via output bit 00.0)
272(1)	Emergency stop discrepancy time exceeded	1. Press emergency stop 2. Acknowledge fault (via output bit 00.0)
272(3)	Door position discrepancy time exceeded	1. Open the door 2. Acknowledge fault (via output bit 00.0)
272(4)	Bolt position discrepancy time exceeded	1. Open the door 2. Acknowledge fault (via output bit 00.0)
272(5)	Guard locking discrepancy time exceeded	1. Open the door 2. Acknowledge fault (via output bit 00.0)
272(6)	Operating mode selector discrepancy time exceeded	1. Search for cause 2. Acknowledge fault (via output bit 00.0)
272(7)	Enabling switch detection discrepancy time exceeded	1. Remove enabling switch 2. Acknowledge fault (via output bit 00.0)
272(8)	Internal device error	Contact our support organization.

Test-pulse error (short-circuit monitoring detected an error)

Notice:

- ▶ Emergency stop must **not** be pressed during acknowledgment.
- ▶ If acknowledgment was unsuccessful, send the device to the manufacturer.

No.	Description	Measures/rectifying errors
273	Test pulses erroneous	Safety function is switched off while no test pulses are being detected. 1. Check system 2. Acknowledgment via output bit 00.0 required.
273(1)	Emergency stop test pulses erroneous	Safety function is switched off while no test pulses are being detected. 1. Check system 2. Acknowledgment via output bit 00.0 required.
273(3)	Door position test pulses erroneous	Safety function is switched off while no test pulses are being detected. 1. Close door 2. Acknowledgment via output bit 00.0 required.
273(4)	Bolt position test pulses erroneous	Safety function is switched off while no test pulses are being detected. 1. Close door 2. Acknowledgment via output bit 00.0 required.
273(5)	Guard locking test pulses erroneous	Safety function is switched off while no test pulses are being detected. 1. Close and lock door 2. Acknowledgment via output bit 00.0 required.
273(6)	Operating mode selector test pulses erroneous	Safety function is switched off while no test pulses are being detected. 1. Check system 2. Acknowledgment via output bit 00.0 required.
273(7)	Enabling switch detection test pulses erroneous	Safety function is switched off while no test pulses are being detected. 1. Check system 2. Acknowledgment via output bit 00.0 required.
273(8)	Internal device error	Contact our support organization.

General messages of the overall system

No.	Description	Measures/rectifying errors
274(2)	Internal device error	Contact our support organization.
274(3)	Signal sequence erroneous (e.g. broken bolt tongue detected)	1. Check mechanical functions 2. Acknowledge fault (via output bit 00.1). The safety door must be open.
274(4)	Plausibility check detected an error (e.g. escape release actuated)	Important: The resetting procedure is contained in the section "Latching fault when actuating the escape release" ▶ Acknowledge fault (via output bit 00.1)
274(5)	Locking module in error	Contact our support organization.
274(6)	Internal device error	Contact our support organization.
274(7)	Internal device error	
274(8)	Internal device error	

Operating mode selector error

No.	Description	Measures/rectifying errors
275(1)	Plausibility check erroneous	Contact our support organization.
275(2)	Internal device error	
275(3)	Internal device error	
275(4)	Internal device error	
275(5)	Internal device error	
275(6)	Internal device error	
275(7)	Internal device error	
275(8)	Internal device error	

PROFIsafe error

No.	Description	Measures/rectifying errors
276(1)	PROFIsafe starting error	Contact our support organization.
276(2)	RAM memory error	
276(3)	FLASH memory error	
276(4)	Communication error	
276(5)	Synchronization error	
276(6)	Voltage monitoring	
276(7)	Internal device error	
276(8)	Hardware fault	

General messages of the overall system

No.	Description	Measures/rectifying errors
277(1)	MGB starting error	Contact our support organization.
277(2)	Communication error	
277(3)	Internal device error	
277(4)	Wrong software version	
277(5)	Internal device error	
277(6)	Internal device error	
277(7)	Internal device error	
277(8)	Internal device error	

No.	Description	Measures/rectifying errors
278(1)	Solenoid control error	Contact our support organization.
278(2)	Error in switching element CPU A	
278(3)	Error in switching element CPU B	
278(4)	Timeout of switching element CPU A	
278(5)	Timeout of switching element CPU B	
278(6)	Internal device error	
278(7)	Internal device error	
278(8)	Internal device error	

Cyclical Profisafe status message

Bit	Description	Measures/rectifying errors
0	Reserved	-
1	Error in F-Device or F-Module	Device is passivated (ON LED flashes). You will find information on depassivating in the manual for your control system.
2	Communication error, CRC error	
3	Communication error, watchdog timeout	
4	Fail-safe values activated	-
5	Toggle bit	-
6	Consecutive number was reset	-
7	Reserved	-

16. PROFINET alarms

16.1. Fault in stacklight module

Short circuits on the stacklight module are output as a PROFINET diagnostic alarm (alarm number 1: short circuit).

17. System status table

LEDs on interlocking/locking module

Operating mode	Door position	Position of the bolt tongue	Guard locking	Door position input bit SI0.2	Bolt position input bit SI0.3	Guard locking input bit SI0.4	ÜK input bit SI1.1	Device diagnostics input bit IO.0	Device diagnostics input bit IO.1	Device diagnostics input bit IO.7	POWER (gn)	STATE (gn)	LED indicator		DIA (rd)	State
													Lock (ye), only MGB-L1/-L2			
Normal operation	open	not inserted	off	off	off	off	off	off	off	X		long OFF short ON	○	○	○	Normal operation, door open
	closed	not inserted	off	off	off	off	off	off	off	X		long ON short OFF	○	○	○	Normal operation, door closed
	closed	inserted	off	off	off	off	off	off	off	X		long ON short OFF	☀	☀	○	Normal operation, door closed, bolt tongue inserted
	closed	inserted	on	on	on	on	on	on	on	X			☀	☀	○	Normal operation, door closed and locked
Teach-in standby (only for MGB unit-code)	open	not inserted	off	off	off	off	off	off	off	X	☀	3 x	○	○	○	Door open: unit is ready for teach-in of another handle module (only short time after power-UP)
	closed	inserted	on	on	on	on	on	on	on	X		1 Hz	○	○	○	Teach-in operation
Setup (only for MGB unit-code)	X	X	X	off	off	off	off	off	off	X	○		○	○	○	Positive acknowledgment after completion of teach-in operation
	X	X	X	off	off	off	off	on	off	X	☀	3 x	○	○		Handle module read error (e.g. error in code or code cannot be read)**
Fault display	X	X	X	off	off	off	off	on	on	X	○		○	○		Internal fault (e.g. component faulty, data error)*
	X	X	X	off	off	off	off	on	off	X	○		☀	☀	1 x	Signal sequence incorrect e.g. broken bolt tongue detected*** or after actuation of the escape release, for example*
Key to symbols	○															LED not illuminated
	☀															LED illuminated
	☀ 10 Hz (8 s)															LED flashes for 8 seconds at 10 Hz
	☀ 3 x															LED flashes three times
X															Any state	

* Latching fault; use corresponding output bit to reset (see chapter 15. MGB system diagnostic messages on page 37)

** Non-latching fault; open guard and close it again to reset

*** Latching fault; use corresponding output bit to reset; door must be open (see chapter 15. MGB system diagnostic messages on page 37)

Important: If you do not find the displayed device status in the system status table, this indicates an internal device fault. In this case, you should contact the manufacturer.

18. Technical data



NOTICE

If a data sheet is included with the product, the information on the data sheet applies.

Parameter	Value
s_{ar} max. door position	65 mm
Housing material	Fiber glass reinforced plastic Die-cast zinc, nickel-plated, stainless steel, powder-coated sheet steel
Dimensions	See dimension drawing
Weight of MGB-L.B (bus module, locking module and operating module with mounting plate)	4.05 kg
Weight of handle module with mounting plate	1.20 kg
Weight of escape release module with mounting plate	1.15 kg
Ambient temperature	-20 ... +55 °C
Degree of protection	IP54
Safety class	III
Degree of contamination	3
Installation orientation	Any
Locking force F_{zh} acc. to GS-ET-19	2,000 N
Connection options, power supply	2 x push-pull power ¹⁾ or 2 x plug connectors 7/8" acc. to ANSI/B93.55M-1981
Connection, bus	2 x RJ 45, push-pull, acc. to IEC 61076-3-117, variant 14, screened ¹⁾ or 2 x M12 (d-coded) acc. to IEC 61076-2-101
Connecting cable, bus	Profinet I/O cable, at least cat. 5e
Operating voltage U_B	DC 24 V +10% / -15% (PELV – see chapter 13. <i>Electrical connection on page 25</i>)
Current consumption, max.	500 mA
Max. feed-in current in the connection block (push-pull plug connector)	4,000 mA
Fuse protection for power supply, external	Min. 1 A slow-blow
Safety outputs	Profisafe acc. to IEC 61784-3-3
Rated insulation voltage U_i	75 V
Rated impulse withstand voltage U_{imp}	0.5 kV
Resilience to vibration and shock	Acc. to EN 60947-5-3
EMC protection requirements	Acc. to EN 61000-4 and DIN EN 61326-3-1
Switching frequency, max.	1 Hz
Risk times, max. (turn-off times) ²⁾	
- Emergency stop	250 ms
- Enabling switch	250 ms
- Operating mode selector	220 ms
- Door position	550 ms
- Bolt position	550 ms
- Guard locking	550 ms
Reliability values acc. to EN ISO 13849-1	
Category	4 (EN 13849-1:2008-12)
Performance Level	PL e (EN 13849-1:2008-12)
MTTF _D ³⁾	91 years
DC	99%
Mission time	20 years
PFD _D ³⁾	
- Monitoring of guard locking	4.07 x 10 ⁻⁸
- Control of guard locking	3.91 x 10 ⁻⁸
- Evaluation of emergency stop, enabling switch, multi-position switch	4.10 x 10 ⁻⁸
B_{10D} ⁴⁾	
- Emergency stop	0.13 x 10 ⁶
- Enabling switch	Acc. to manufacturer's specifications

1) The document *PROFINET Cabling and Interconnection Technology* from the PNO aids in the correct selection of cables.

2) The risk time is the max. time between the change in the input status and the clearing of the corresponding bit in the bus protocol.

3) Fixed failure rate without consideration of faults in wearing parts.

4) Information regarding wearing parts without consideration of fixed failure rates in electronic components.

18.1. Dimension drawings

Locking set

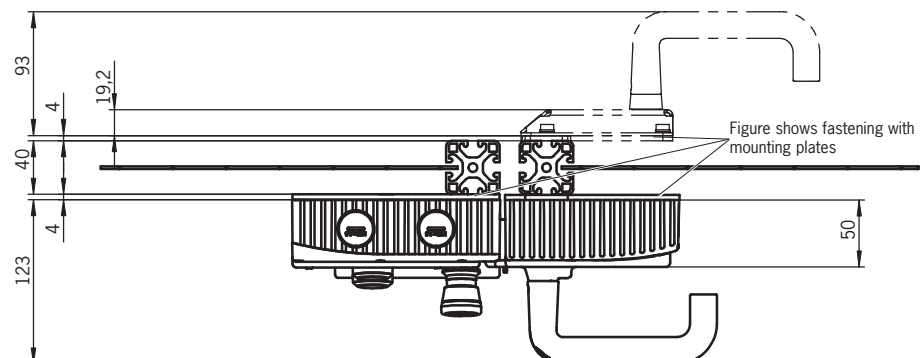
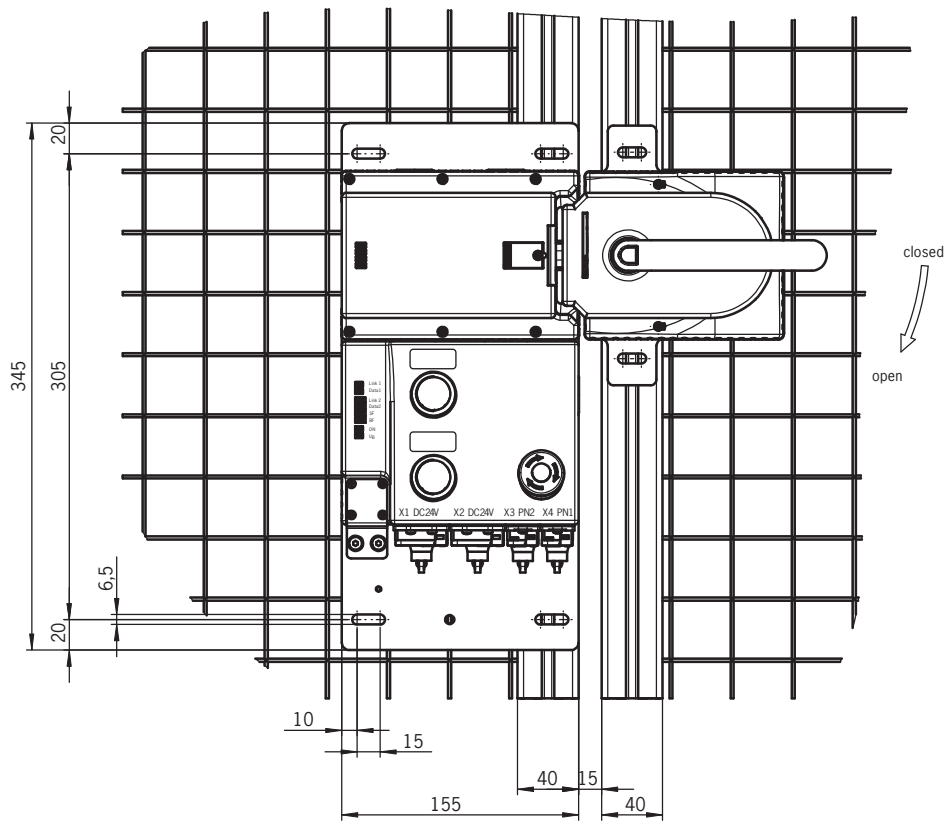
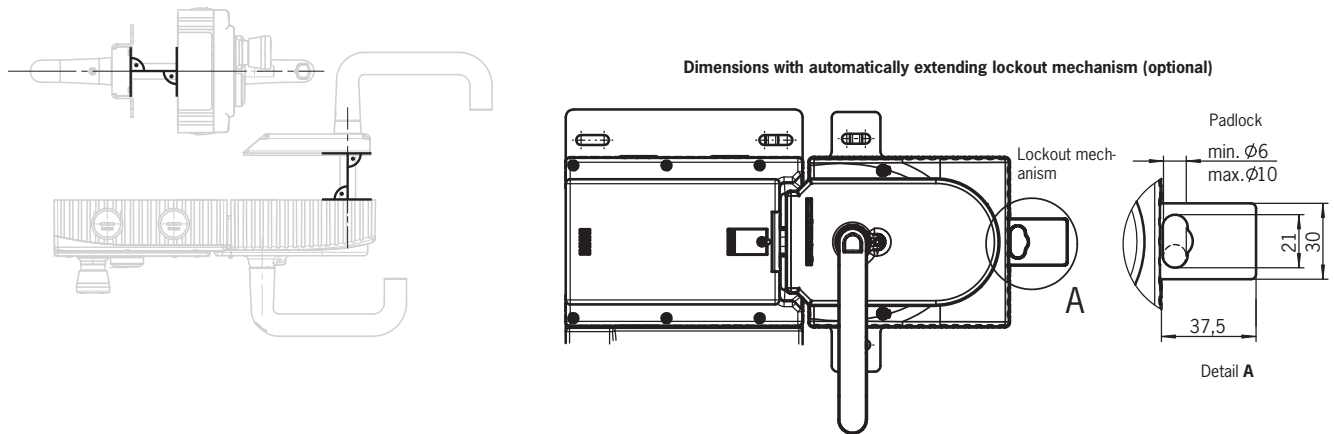

(Figure shows version for doors hinged on the right, pre-assembled on mounting plates)

Locking set

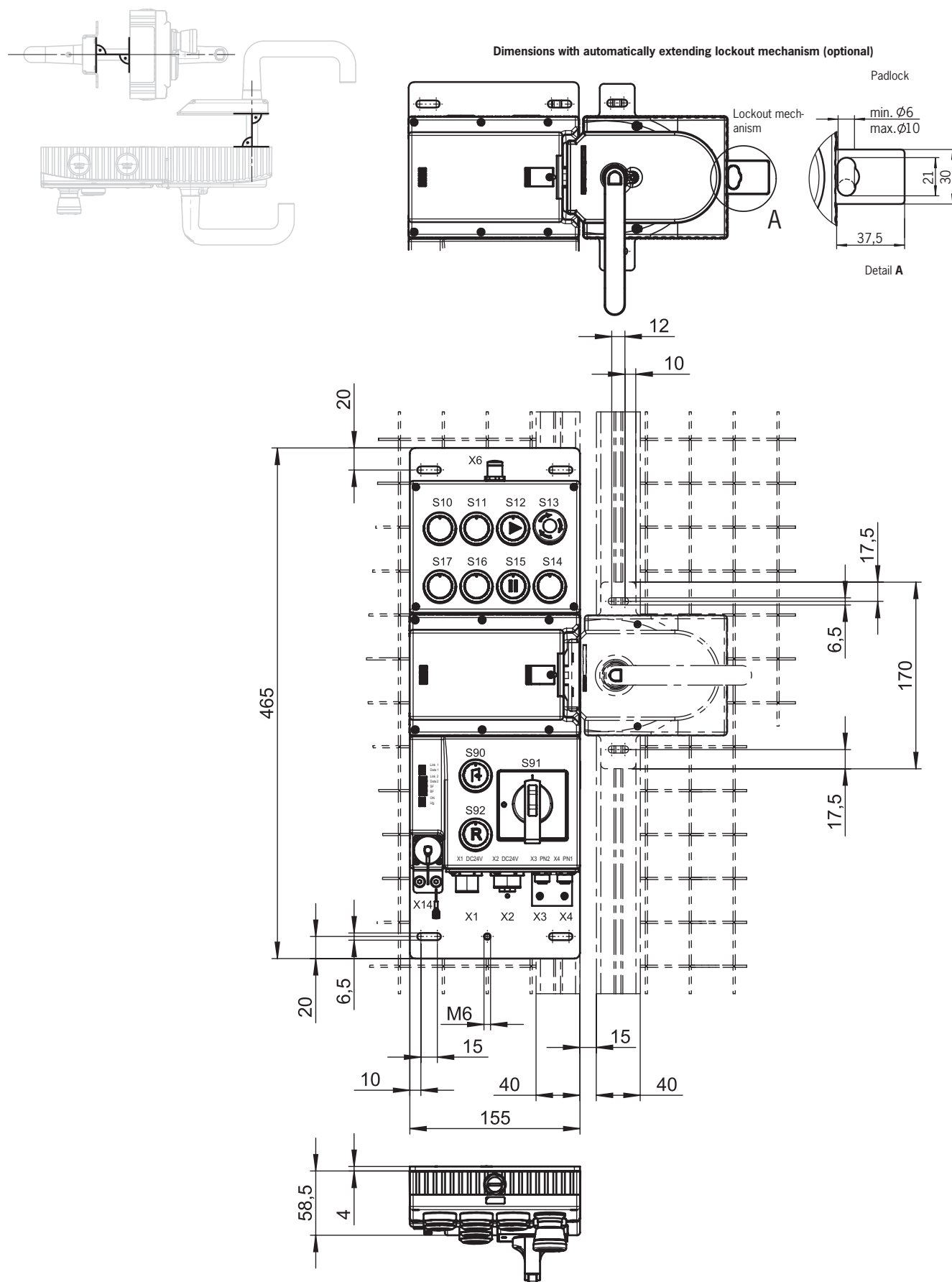

(Figure shows version for doors hinged on the right, pre-assembled on mounting plates)

Control module MGB-B-...-PN on mounting plate

(example based on MGB-B-A1W2A2-PN-123759)

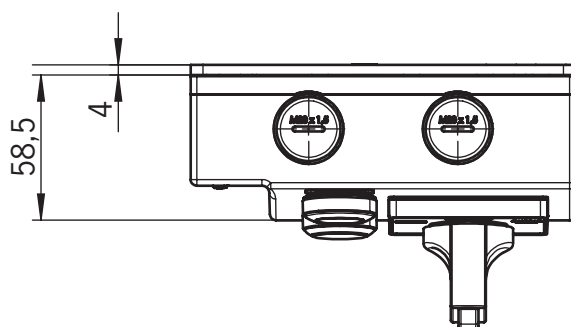
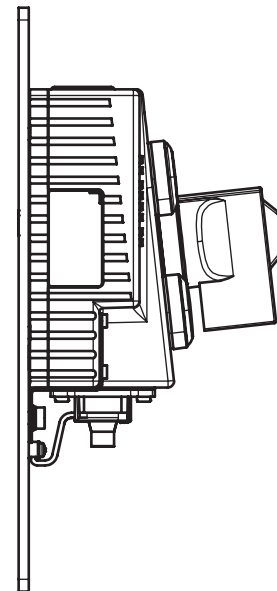
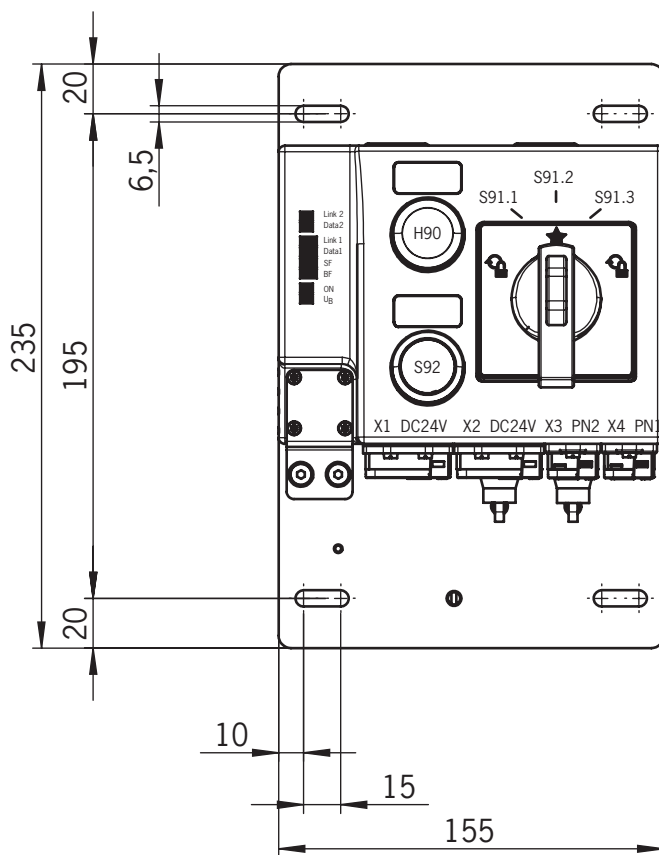
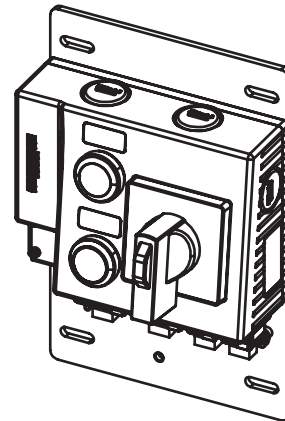

Control module MGB-CB-...-PN on mounting plate
 (example based on MGB-CB-PN-114744)

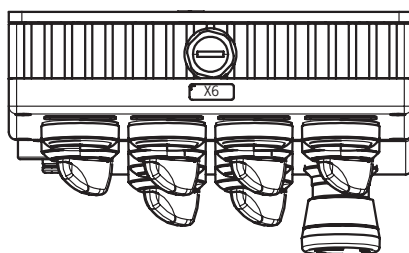
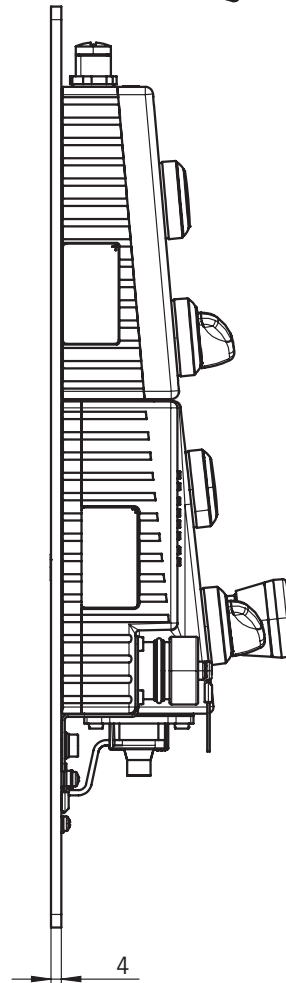
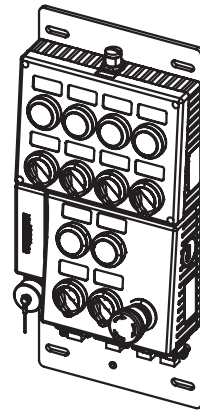
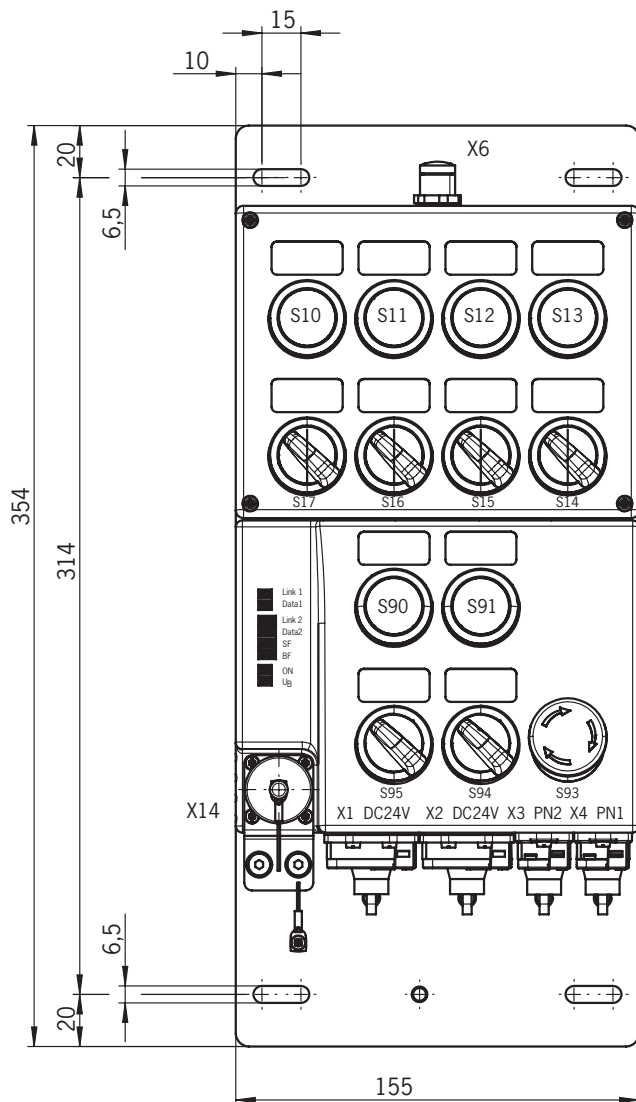

19. Troubleshooting and assistance

19.1. Latching fault when actuating the escape release

In order to achieve monitoring of the locking element in category 4, PL e according to EN ISO 13849-1, an internal monitoring logic system is integrated into every locking module.

Result: The MGB system enters into a latching fault when the escape release is actuated (see 17. System status table on page 39).

Door position	Position of the bolt tongue	Guard locking	Door position input bit SIO.2	Bolt position input bit SIO.3	Guard locking input bit SIO.4	ÜK input bit SI1.1	Device diagnostics input bit IO.0	Device diagnostics input bit IO.1	Device diagnostics input bit IO.7	LED indicator				State
										Power (gn)	State (gn)	Lock (ye)	DIA (rd)	
X	X	X	off	off	off	off	on	on	X				1 x	Signal sequence incorrect (e.g. after actuation of the escape release)*
														LED not illuminated
														LED illuminated
								10 Hz (8 s)						LED flashes for 8 seconds at 10 Hz
								3 x						LED flashes three times
							X							Any state



NOTICE

The system might not enter into a latching fault if the escape release is actuated very slowly.

19.2. Resetting errors

Proceed as follows:

1. Acknowledge fault via output bit OO.1 (in data block for diagnostics function).
 2. Close guard if necessary and switch on guard locking.
- ➔ The system is in normal operation again.

19.3. Troubleshooting help on the Internet

You will find a help file on troubleshooting under "Support" in the service area at www.euchner.com.

19.4. Mounting help on the Internet

You will find an animation on the mounting process at www.euchner.com.

19.5. Application examples

You will find application examples on connecting the device to various control systems at www.euchner.com.

20. Service

If servicing is required, please contact:

Euchner GmbH + Co. KG
Kohlhammerstraße 16
70771 Leinfelden-Echterdingen
Germany

Service telephone:

+49 711 7597-500

E-mail:

support@euchner.de

Internet:

www.euchner.com

21. Inspection and service



WARNING

Loss of the safety function because of damage to the device.
In case of damage, the affected module must be replaced completely. Only accessories or spare parts that can be ordered from Euchner may be replaced.

Regular inspection of the following is necessary to ensure trouble-free long-term operation:

- › Check the switching function (see chapter 14.6. *Electrical function test on page 28*)
- › Check the secure mounting of the devices and the connections
- › Check for soiling

No servicing is required. Repairs to the device are only allowed to be made by the manufacturer.



NOTICE

The year of manufacture can be seen in the lower right corner of the rating plate.

22. Declaration of conformity

More than safety.



EUCHNER

EUCHNER GmbH + Co. KG
Kohlhammerstraße 16
70771 Leinfelden-Echterdingen
Germany

EG-Konformitätserklärung
EC-Declaration of Conformity
CE-Déclaration de Conformité
CE-Dichiarazione di conformità
CE-Declaración de conformidad

Original DE
Translation EN
Traduction FR
Traduzione IT
Traducción ES

123624-02-02/15

Die nachfolgend aufgeführten Produkte sind konform mit den Anforderungen der folgenden Richtlinien (falls zutreffend):
The beneath listed products are in conformity with the requirements of the following directives (if applicable):
Les produits mentionnés ci-dessous sont conformes aux exigences imposées par les directives suivantes (si valable)
I prodotti sotto elencati sono conformi alle direttive sotto riportate (dove applicabili):
Los productos listados a continuación son conforme a los requisitos de las siguientes directivas (si fueran aplicables):

I:	2006/42/EG	Maschinenrichtlinie
	2006/42/EC	Machinery directive
	2006/42/CE	Directive Machines
	2006/42/CE	Direttiva Macchine
	2006/42/CE	Directiva de máquinas

Die Schutzziele der Niederspannungsrichtlinie wurden gemäß Anhang I, Nr. 1.5.1 der Maschinenrichtlinie eingehalten.
The safety objectives of the Low-Voltage Directive comply with Annex I, No. 1.5.1 of the Machinery Directive.
Les objectifs de sécurité de la Directive Basse Tension sont conformes à l'annexe I, No. 1.5.1 de la Directive Machines
Gli obiettivi di sicurezza della Direttiva Bassa Tensione sono conformi a quanto riportato all'allegato I, No. 1.5.1 della Direttiva Macchine.
Los objetivos de seguridad de la Directiva de Bajo Voltaje cumplen con el Anexo I, No. 1.5.1 de la Directiva de Máquinas

Folgende Normen sind angewandt:
Following standards are used:
Les normes suivantes sont appliquées:
Vengono applicate le seguenti norme:
Se utilizan los siguientes estándares:

a:	EN 60947-5-3:1999/A1:2005
b:	EN ISO 14119:2013
c:	EN ISO 13849-1:2008
d:	EN 61784-3-3:2008 (Profisafe)
e:	EN 60947-5-5:1997/A1:2005

Bezeichnung der Bauteile <i>Description of components</i> <i>Description des composants</i> <i>Descrizione dei componenti</i> <i>Descripción de componentes</i>	Type <i>Type</i> <i>Type</i> <i>Tipo</i> <i>Typo</i>	Richtlinie <i>Directives</i> <i>Directive</i> <i>Direttiva</i> <i>Directivas</i>	Normen <i>Standards</i> <i>Normes</i> <i>Norme</i> <i>Estándares</i>	Zertifikats-Nr. <i>No. of certificate</i> <i>Numéro du certificat</i> <i>Numero del certificato</i> <i>Número del certificado</i>
Sicherheitsschalter <i>Safety Switches</i> <i>Interrupteurs de sécurité</i> <i>Fincorsa di sicurezza</i> <i>Interruptores de seguridad</i>	MGB...PN ...	I	a, b, c, d	Z10 10 04 40393 008
	MGB-B...PN...	I	c, d	Z10 10 04 40393 008
	MGB-CB...PN...	I	c, d	Z10 10 04 40393 008
Sicherheitsschalter mit Not-Halt-Einrichtungen <i>Safety Switches with Emergency-Stop facilities</i> <i>Interrupteurs de sécurité avec appareillage arrêt d'urgence</i> <i>Fincorsa di sicurezza con dispositivi di arresto di emergenza</i> <i>Interruptores de seguridad con dispositivos de parada de emergencia</i>	MGB...PN ...	I	a, b, c, d, e	Z10 10 04 40393 008
	MGB-B...PN...	I	c, d, e	Z10 10 04 40393 008
	MGB-CB...PN...	I	c, d, e	Z10 10 04 40393 008

Benannte Stelle
Notified Body
Organisme notifié
Sede indicata
Entidad citada

NB 0123
TÜV SÜD Product Service GmbH
Ridlerstrasse 65
80339 München
Germany

i.A. Dipl.-Ing. Richard Holz
Leiter Elektronik-Entwicklung
Manager Electronic Development
Responsable Développement Électronique
Direttore Sviluppo Elettronica
Director de desarrollo electrónico

i.A. Dipl.-Ing. (FH) Duc Binh Nguyen
Dokumentationsbevollmächtigter
Documentation manager
Responsable documentation
Responsabilità della documentazione
Agente documenta

Leinfelden, Februar 2015

EUCHNER GmbH + Co. KG
Kohlhammerstraße 16
70771 Leinfelden-Echterdingen
Germany

Euchner GmbH + Co. KG
Kohlhammerstraße 16
70771 Leinfelden-Echterdingen
Germany
info@euchner.de
www.euchner.com

Edition:
2115174-09-02/21
Title:
Operating Instructions Safety Systems
MGB-L..B-PN-... (PROFINET) and With Data Structure Type B
From V3.30.0
(translation of the original operating instructions)
Copyright:
© Euchner GmbH + Co. KG, 02/2021

Subject to technical modifications; no responsibility is accepted for the accuracy of this information.