

EUCHNER

Operating Instructions Installation and Use



Modular Safety Control System MSC

EN

Contents

1.	About this document	7
1.1.	Scope.....	7
1.2.	Target group	7
1.3.	Key to symbols.....	7
1.4.	Supplementary documents	7
1.5.	Exclusion of liability and warranty	7
2.	Introduction	8
2.1.	Contents of this manual.....	8
2.2.	Important safety precautions	8
2.3.	Abbreviations and symbols	9
2.4.	Applicable standards.....	9
2.5.	Combination options for the MSC system	9
3.	Overview	10
4.	Layout of the product	12
5.	Installation	13
5.1.	Mechanical mounting	13
5.2.	Calculation of the safety distance for an item of ESPE connected to the MSC system	14
5.3.	Electrical connections	15
5.3.1.	Notes in relation to connecting cables	15
5.3.2.	Notes on 	16
5.3.2.1.	Base unit MSC-CB	16
5.3.2.2.	Base unit MSC-CB-S	17
5.3.3.	USB connection	18
5.3.4.	MSC configuration memory (M-A1).....	18
5.3.4.1.	MULTIPLE LOAD function.....	18
5.3.4.2.	RESTORE function	19
5.3.5.	Module FI8FO2	19
5.3.6.	Module FI8FO4S.....	20
5.3.7.	Module FI8	21
5.3.8.	Module FM4	21
5.3.9.	Module FI16	22
5.3.10.	Module AC-FO4	23
5.3.11.	Module AC-FO2	23
5.3.12.	Modules SPM0 – SPM1 – SPM2	24
5.3.12.1.	Encoder connections with RJ45 plug connector (SPM1, SPM2).....	24
5.3.13.	Module AZ-FO4	26
5.3.14.	Module AZ-FO4O8	26
5.3.15.	Module O8	27
5.3.16.	Module O16	27
5.3.17.	Module AH-FO4SO8.....	28
5.3.18.	Example for the connection of the MSC system to the machine control	28
5.4.	Checklist after installation.....	29
6.	Flow chart	30

7.	Signals	31
7.1.	Inputs	31
7.1.1.	MASTER_ENABLE	31
7.1.2.	NODE_SEL	31
7.1.3.	Proximity switch input on speed monitoring modules SPM	32
7.1.4.	RESTART_FBK	33
7.2.	Outputs	34
7.2.1.	OUT_STATUS	34
7.2.2.	OUT_TEST	34
7.2.3.	OSSD	34
7.2.3.1.	Single-channel OSSDs (MSC-CB-S, FI8FO4S, AH-FO4SO8)	34
7.2.3.2.	High current OSSD (AH-FO4SO8)	36
7.2.4.	Safety relays (AZ-FO4, AZ-FO4O8)	36
8.	Technical data	37
8.1.	General system settings	37
8.1.1.	Safety-related parameters	37
8.1.2.	General data	37
8.1.3.	Housing	38
8.1.4.	Module MSC-CB	38
8.1.5.	Module MSC-CB-S	39
8.1.6.	Module FI8FO2	39
8.1.7.	Module FI8FO4S	39
8.1.8.	Modules FI8 – FI16	39
8.1.9.	Module FM4	39
8.1.10.	Modules AC-FO2 – AC-FO4	40
8.1.11.	Module AH-FO4SO8	40
8.1.12.	Modules SPM0 – SPM1 – SPM2	40
8.1.13.	Modules AZ-FO4 – AZ-FO4O8	41
8.1.14.	Modules O8 – O16	41
8.2.	Mechanical dimensions	42
8.3.	Signals	43
8.3.1.	Base unit MSC-CB (Figure 13)	43
8.3.2.	Base unit MSC-CB-S (Figure 14)	44
8.3.3.	Module FI8FO2 (Figure 15)	45
8.3.4.	Module FI8FO4S (Figure 16)	46
8.3.5.	Module FI8 (Figure 17)	47
8.3.6.	Module FM4 (Figure 18)	48
8.3.7.	Module FI16 (Figure 19)	49
8.3.8.	Module AC-FO2 (Figure 20)	50
8.3.9.	Module AC-FO4 (Figure 21)	51
8.3.10.	Module AZ-FO4 (Figure 22)	52
8.3.11.	Module AZ-FO4FO8 (Figure 23)	53
8.3.12.	Module O8 (Figure 24)	54
8.3.13.	Module O16 (Figure 25)	55
8.3.14.	Modules SPM0 – SPM1 – SPM2 (Figure 26)	56
8.3.15.	Module AH-FO4SO8 (Figure 27)	57
8.4.	Fault diagnostics	58
8.4.1.	Base unit MSC-CB (Figure 28)	58
8.4.2.	Base unit MSC-CB-S (Figure 29)	59
8.4.3.	Module FI8FO2 (Figure 30)	60
8.4.4.	Module FI8FO4S (Figure 31)	61
8.4.5.	Module FI8 (Figure 32)	62
8.4.6.	Module FM4 (Figure 33)	63
8.4.7.	Module FI16 (Figure 34)	64
8.4.8.	Modules AC-FO2/AC-FO4 (Figure 35)	65

8.4.9.	Module AZ-F04 (Figure 36)	66
8.4.10.	Module AZ-F0408 (Figure 37)	67
8.4.11.	Module O8 (Figure 38)	68
8.4.12.	Module O16 (Figure 39)	69
8.4.13.	Modules SPM0, SPM1, SPM2 (Figure 40)	70
8.4.14.	Module AH-F04S08 (Figure 41)	71
9.	EUCHNER Safety Designer software	72
9.1.	Installing the software	72
9.1.1.	PC hardware system prerequisites	72
9.1.2.	PC software system prerequisites	72
9.1.3.	EUCHNER Safety Designer is installed as follows	72
9.1.4.	General	73
9.1.5.	Default toolbar	73
9.1.6.	Menu bar	75
9.1.7.	Creating a new project (configuring MSCB system)	75
9.1.7.1.	Changing configuration (layout of the various modules)	76
9.1.7.2.	Editing user parameters	76
9.1.8.	Tool bars for ITEMS, OPERATOR, CONFIGURATION	76
9.1.9.	Preparing the diagram	77
9.1.9.1.	Using the right mouse button	78
9.1.10.	Example for a project	79
9.1.10.1.	Project validation	80
9.1.10.2.	Resources allocation	81
9.1.10.3.	Print report	81
9.1.10.4.	Connecting to MSC	83
9.1.10.5.	Sending the configuration to the MSC system	83
9.1.10.6.	Downloading a configuration file (project) from the base unit	84
9.1.10.7.	Configuration log	84
9.1.10.8.	System layout	85
9.1.10.9.	Disconnecting the system	85
9.1.10.10.	Monitor (real-time I/O status – text form)	86
9.1.10.11.	Monitor (real-time I/O status – text – graphic)	87
9.1.11.	Password protection	88
9.1.11.1.	Password level 1	88
9.1.11.2.	Password level 2	88
9.1.11.3.	Password change	88
9.1.12.	Checking the system	89
9.2.	Item-specific function blocks	90
9.2.1.	Output items	90
9.2.1.1.	Safety outputs (OSSD)	90
9.2.1.2.	Safety output (single-double OSSD)	91
9.2.1.3.	Signal output (STATUS)	93
9.2.1.4.	Fieldbus output (FIELDBUS PROBE)	94
9.2.1.5.	Relay [RELAY]	94
9.2.2.	Input items	98
9.2.2.1.	Emergency stop (E-STOP)	98
9.2.2.2.	Interlock (INTERLOCK)	99
9.2.2.3.	Single-channel interlock (SINGLE INTERLOCK)	101
9.2.2.4.	Guard locking monitoring (LOCK FEEDBACK)	102
9.2.2.5.	Key-operated rotary switch (KEY LOCK SWITCH)	103
9.2.2.6.	Optoelectronic safety light grid or safety laser scanner (ESPE)	105
9.2.2.7.	Safety footswitch (FOOTSWITCH)	106
9.2.2.8.	Operating mode selection (MOD-SEL)	108
9.2.2.9.	Light barrier (PHOTOCELL)	109
9.2.2.10.	Two-hand control (TWO-HAND)	111
9.2.2.11.	NETWORK_IN	112
9.2.2.12.	SENSOR	113

9.2.2.13.	Pressure sensitive mat (S-MAT).....	115
9.2.2.14.	Switch (SWITCH)	117
9.2.2.15.	Enabling switch (ENABLING SWITCH)	118
9.2.2.16.	Testable safety device (TESTABLE SAFETY DEVICE)	120
9.2.2.17.	Semiconductor output (SOLID STATE DEVICE)	122
9.2.2.18.	Fieldbus input (FIELDBUS INPUT)	123
9.2.2.19.	LLO – LL1.....	124
9.2.2.20.	Comments.....	124
9.2.2.21.	Title	124
9.3.	Function blocks for speed control	125
9.3.1.	Speed monitoring (SPEED CONTROL).....	126
9.3.2.	Speed range monitoring (WINDOW SPEED CONTROL).....	129
9.3.3.	Standstill monitoring (STAND STILL)	131
9.3.4.	Speed/standstill monitoring (STAND STILL AND SPEED CONTROL).....	133
9.4.	Function blocks in the “OPERATOR” window	136
9.4.1.	Logical operators.....	136
9.4.1.1.	AND	136
9.4.1.2.	NAND.....	136
9.4.1.3.	NOT	136
9.4.1.4.	OR	137
9.4.1.5.	NOR.....	137
9.4.1.6.	XOR	137
9.4.1.7.	XNOR.....	138
9.4.1.8.	Logical macro (LOGICAL MACRO)	138
9.4.1.9.	MULTIPLEXER	139
9.4.1.10.	Digital comparator (DIGITAL COMPARATOR) (only with MSC-CB-S).....	139
9.4.2.	Memory operators	141
9.4.2.1.	D FLIP FLOP (max. number = 16 with MSC-CB, max. number = 32 with MSC-CB-S).....	141
9.4.2.2.	T FLIP FLOP (max. number = 16 with MSC-CB, max. number = 32 with MSC-CB-S).....	141
9.4.2.3.	SR FLIP-FLOP.....	142
9.4.2.4.	Manual restart (USER RESTART MANUAL) (max. number = 16 with MSC-CB, max. number = 32 with MSC-CB-S including other RESTART operators).....	142
9.4.2.5.	Monitored restart (USER RESTART MONITORED) (max. number = 16 with MSC-CB, max. number = 32 with MSC-CB-S including other RESTART operators).....	143
9.4.2.6.	Manual restart macro (MACRO RESTART MANUAL) (max. number = 16 with MSC-CB, max. number = 32 with MSC-CB-S including other RESTART operators).....	144
9.4.2.7.	Macro monitored restart (MACRO RESTART MONITORED) (max. number = 16 with MSC-CB, max. number = 32 with MSC-CB-S including other RESTART operators).....	145
9.4.2.8.	PRE-RESET (only MSC-CB-S, max. number = 32 including other restart operators).....	146
9.4.3.	Guard locking operators	147
9.4.3.1.	Guard locking logic (GUARD LOCK) (max. number with MSC-CB = 4, max. number with MSC-CB-S = 8).....	147
9.4.4.	COUNTER operators	149
9.4.4.1.	Counter (COUNTER) (max. number = 16)	149
9.4.4.2.	Timer value comparison (COUNTER COMPARATOR) (only MSC-CB-S and MSC-CB ≥ 4.0).....	150
9.4.5.	TIMER operators (max. number = 32 with MSC-CB, max. number = 48 with MSC-CB-S).....	151
9.4.5.1.	MONOSTABLE.....	151
9.4.5.2.	MONOSTABLE_B.....	152
9.4.5.3.	Passing make contact (PASSING MAKE CONTACT).....	153
9.4.5.4.	Delay (DELAY).....	154
9.4.5.5.	Long-term delay (LONG DELAY) (only MSC-CB-S and MSC-CB ≥ 4.0).....	155
9.4.5.6.	Timer value comparison (DELAY COMPARATOR) (only MSC-CB-S and MSC-CB ≥ 4.0).....	156
9.4.5.7.	Delay line (DELAY LINE)	157
9.4.5.8.	Long-term delay line (LONG DELAY LINE) (only MSC-CB-S and MSC-CB ≥ 4.0).....	157
9.4.5.9.	Clock generation (CLOCKING)	158
9.4.6.	The MUTING function.....	159

9.4.7.	MUTING operators (max. number = 4 with MSC-CB, max. number = 8 with MSC-CB-S).....	159
9.4.7.1.	Simultaneous muting (MUTING “Con”)	159
9.4.7.2.	MUTING “L”	161
9.4.7.3.	“Sequential” MUTING	162
9.4.7.4.	MUTING “T”	164
9.4.7.5.	MUTING OVERRIDE.....	165
9.5.	Other function blocks	167
9.5.1.	Serial output (SERIAL OUTPUT) (max. number = 4)	167
9.5.2.	OSSD EDM (only MSC-CB-S) (max. number = 32).....	168
9.5.3.	TERMINATOR	168
9.5.4.	Network (NETWORK) (max. number = 1)	169
9.5.5.	Reset (RESET)	173
9.5.6.	Interpage In/Out	173
9.5.7.	Input/output for internal feedback (max. number = 8, only MSC-CB-S \geq 6.0).....	174
9.6.	Special applications	175
9.6.1.	Output delay with manual operating mode.....	175
9.7.	Simulator	176
9.7.1.	Schematic simulation	177
9.7.2.	Administration of the graphic simulation.....	179
9.7.2.1.	Application example for the graphic simulation	182
9.7.3.	MSC error codes	184
9.7.4.	Error log file	185
10.	Ordering information and accessories	186
11.	Inspection and service	186
12.	Service	186
13.	Declaration of conformity	186

1. About this document





1.1. Scope

These operating instructions are valid for the Modular Safety Control System MSC. These operating instructions and any brief instructions enclosed form the complete user information for your device.

1.2. Target group





Design engineers and installation planners for safety devices on machines, as well as setup and servicing staff possessing special expertise in handling safety components.

1.3. Key to symbols

Symbol/depiction	Meaning
	Printed document
	Document is available for download at www.euchner.com
 DANGER WARNING CAUTION	Safety precautions Danger of death or severe injuries Warning about possible injuries Caution slight injuries possible
 NOTICE Important!	Notice about possible device damage Important information
Tip!	Useful information

1.4. Supplementary documents

The overall documentation for this device consists of the following documents:

Document title (document number)	Contents	
Operating Instructions Modular Safety Control System MSC (2121331)	This document	 
Possibly brief instructions enclosed	Item-specific information about deviations or additions	 



Important!

Always read all documents to gain a complete overview of safe installation, setup and use of the device. The documents can be downloaded from www.euchner.com. For this purpose enter the doc. no. in the search box.

1.5. Exclusion of liability and warranty

In case of failure to comply with the conditions for correct use stated above, or if the safety regulations are not followed, or if any servicing is not performed as required, liability will be excluded and the warranty void.

2. Introduction

2.1. Contents of this manual

The use of the programmable safety system MSC and the related extension modules ("SLAVES") is described in this manual.

It covers:

- › System description
- › Installation procedure
- › Connections
- › Signals
- › Troubleshooting
- › Use of the configuration software

2.2. Important safety precautions



WARNING

- › MSC achieves the following safety levels: SIL 3, SILCL 3, PL e, cat. 4, type 4 as per the applicable standards.
However, the final SIL and PL safety categories for the application are dependent on the number of safety components, their parameters and the connections made, as per the risk analysis.
- › Read the section "Applicable standards" carefully.
- › Perform a comprehensive risk analysis to determine the corresponding safety level for the specific application based on all applicable standards.
- › The programming/configuration of the MSC system is the sole responsibility of the installer or the user.
- › This programming/configuration must correspond to the application-specific risk analysis and all applicable standards.
- › After programming/configuration and installation of the MSC system and all related devices, a complete application safety check must be performed (see section "Checking the system" on page 89).
- › After adding new safety components, the complete system must always be checked (see section "Checking the system" on page 89).
- › EUCHNER is not liable for these processes or for the related risks.
- › To ensure the correct use of the modules connected to the MSC system within the stated application, reference should be made to the operating instructions/manuals and the related product and/or application standards.
- › The ambient temperature at the installation location for the system must match the operating temperatures stated on the product label and in the specifications.
- › In the event of safety-related questions, if necessary contact the responsible safety authorities in your country or the responsible specialist association.

2.3. Abbreviations and symbols

Abbreviations and symbols	
M-A1	Memory card for MSC-CB (accessory)
MSCB	Proprietary bus for extension modules
EUCHNER Safety Designer (SWSD)	MSC configuration software for Windows
OSSD	Output signal switching device
MTTF_D	Mean Time to Dangerous Failure
PL	Performance Level (according to EN ISO 13849-1)
PFH_D	Probability of Dangerous Failure per Hour
SIL	Safety Integrity Level (according to EN 61508)
SILCL	Safety Integrity Level Claim Limit (according to EN 62061)
SW	Software

2.4. Applicable standards

MSC complies with the following European directives:

- 2006/42/EC “Machinery Directive”
- 2014/30/EU “EMC Directive”
- 2006/95/EC “Low Voltage Directive”

It additionally corresponds to the following standards:	
EN IEC 61131-2	Industrial-process control systems – Instruments with analogue inputs and two- or multi-state outputs – Part 2: Guidance for inspection and routine testing
EN ISO 13489-1	Safety of machinery – Safety-related parts of control systems – Part 1: General principles for design
EN IEC 61496-1	Safety of machinery – Electro-sensitive protective equipment – Part 1: General requirements and tests
EN IEC 61508-1	Functional safety of electrical/electronic/programmable electronic safety-related systems – Part 1: General requirements
EN IEC 61508-2	Functional safety of electrical/electronic/programmable electronic safety-related systems – Part 2: Requirements for electrical/electronic/programmable electronic safety-related systems
EN IEC 61508-3	Functional safety of electrical/electronic/programmable electronic safety-related systems – Part 3: Software requirements
EN IEC 61784-3	Industrial communication networks – Profiles – Part 3: Functional safety fieldbuses – General rules and profile definitions
EN IEC 62061	Safety of machinery – Functional safety of safety-related electrical, electronic and programmable electronic control systems

Table 1: Applicable standards

2.5. Combination options for the MSC system

Base unit	Extension module	
	MSC-CE-...S	MSC-CE-...
MSC-CB-AC-F18F04S	●	●
MSC-CB-AC-F18F02	-	●
Key to symbols	●	Combination possible
	-	Combination not possible

3. Overview

MSC is a modular safety system and comprises a base unit (MSC-CB), which can be configured using the graphic user interface EUCHNER Safety Designer, and various extension modules that can be connected via the proprietary MSCB bus to MSC-CB.

Two base units that can be used as standalone devices are available.

- › **MSC-CB** with 8 safety inputs, 2 programmable signal outputs and 2 separate, programmable dual-channel safety outputs (OSSD)
- › **MSC-CB-S** with 8 safety inputs, up to 4 programmable signal outputs and 2 separate, programmable dual-channel or 4 separate, programmable single-channel safety outputs (OSSD)



Important!

The following extension modules are available:

- › **F18FO2, F18FO4S** with inputs and outputs,
- › **F18, FM4, FI16, SPMO, SPM1** and **SPM2** only with inputs,
- › **AC-FO2** and **AC-FO4** only with outputs,
 - plus **O8, O16** and **AH-FO4S08** with monitoring outputs,
 - as well as **AZ-FO4** and **AZ-FO408** with positively driven safety relays.

Extension modules for connection to the most common industrial fieldbus systems for diagnostics are also available: **CE-PR** (PROFIBUS), **CE-CO** (CanOpen), **CE-DN** (DeviceNet), **CE-EI** (ETHERNET/IP), **CE-EI2** (ETHERNET/IP-2PORT), **CE-PN** (Profinet), **CE-EC** (ETHERCAT), **CE-MR** (Modbus RTU), **CE-MT** (Modbus/TCP).

MSC makes it possible to monitor the following safety sensors and command switches:

Optoelectronic sensors (safety light grids, scanners, safety light barriers), mechanical switches, safety mats, emergency stop buttons, two-hand controls, which are all managed via one single, flexible device that can be expanded.

The system is only allowed to comprise a single base unit MSC-CB or MSC-CB-S and a maximum of 14 electronic extension modules, of which not more than four are allowed to be of the same type.

With 14 extension modules the system can have up to 128 inputs, 30 dual-channel safety outputs and 48 status outputs. The modules AZ-FO4/AZ-FO408 have four 1-channel outputs. The greater the number of AZ-FO4/AZ-FO408 modules used, the fewer dual-channel outputs are available.

The communication between the base unit (MASTER) and the extension modules (SLAVES) is via the MSCB 5-way bus (proprietary bus from EUCHNER) on the rear side of every module.

In addition, up to 32 inputs and up to 32 outputs are available and can be controlled using sensors (via the fieldbus).

The number of inputs in the system can be increased using the MSC extension modules **F18, FI16** and **FM4** such that more external devices can be connected. **FM4** also provides 8 outputs of type OUT_TEST.

With the extension modules AC-FO2 and AC-FO4, the MSC system has 2 or 4 OSSD pairs to control devices connected downstream of the MSC system.

AH-FO4S08 is a safety module with 4 single-channel high-current safety outputs and 4 associated inputs for external device monitoring contacts (EDM). The module is also equipped with 8 programmable signal outputs.

F18FO2 has 8 inputs, 2 programmable signal outputs and 2 dual-channel OSSD outputs.

F18FO4S has 8 inputs, up to 4 programmable signal outputs and 4 single-channel OSSD outputs.

The extension modules in the **CE** series make it possible to connect the most common industrial fieldbus systems for diagnostics and data transmission. **CE-EI, CE-EI2, CE-PN, CE-MT** and **CE-EC** also have an Ethernet connection. **CE-US** makes it possible to connect devices with a USB port.

CE-CI1, CE-CI2 are modules in the **MSC** family that make it possible to connect with extension modules further away (< 50 m). Two **CE-CI** are connected at the required distance using a screened cable (as per the table for the technical cable data).

The following can be monitored (up to PL e) using the extension modules for speed monitoring **SPM0**, **SPM1** and **SPM2**:

- › Standstill, overspeed, speed range
- › Direction of motion, rotary motion/linear motion

Up to 4 speed limits can be defined for each logical output (axis).

Each module has two logical outputs that can be configured via EUCHNER Safety Designer. In this way up to two independent axes can be monitored.

The safety modules **AZ-F04** and **AZ-F0408** have 4 separate safety relay outputs and the corresponding 4 inputs for the external device monitoring contacts (EDM).

Two settings are available for the outputs (configuration via the EUCHNER Safety Designer software):

- › 2 pairs of connection contacts (2 normally open contacts per output with 2 corresponding feedback loop inputs).
- › 4 separate individual connection contacts (1 normally open contact per output with 1 corresponding feedback loop input).

Only the modules **AZ-F0408**, **AH-F04S08** and **O8** have 8 programmable signal outputs and the module **O16** has 16 programmable signal outputs.

With the EUCHNER Safety Designer software, complex logic elements can be configured using logical operators and safety functions such as muting, timers and counters, etc.

All this is achieved using a straightforward, intuitive graphic user interface.

The configuration on the PC is sent via a USB connection to base unit **MSC-CB** or **MSC-CB-S**. The file is saved in **MSC-CB/ MSC-CB-S** and can also be saved on the proprietary **M-A1** memory card (accessory). In this way, it is possible to copy the configuration to a different **base unit** quickly.



Important!

The MSC system is certified for the highest safety level included in the applicable industrial safety standards (SIL 3, SILCL 3, PL e, cat. 4).

4. Layout of the product

The scope of delivery of the MSC-CB or MSC-CB-S includes:

- › CD-ROM with the free-of-charge EUCHNER Safety Designer software, this multilingual manual (PDF format) and other product literature
- › Multilingual installation instructions



Important!

The MSCB plug connector on the rear and the M-A1 memory card can be ordered separately.

The scope of delivery of the extension modules includes:

- › Multilingual installation instructions
- › Rear MSCB plug connector



Important!

The supplied MSCB plug connector and a further MSCB plug connector are required for the connection to the MSC-CB/MS-CB-S to install an extension module. This can be ordered separately as an accessory.

5. Installation

5.1. Mechanical mounting

Fasten the modules of the MSC system to a 35-mm DIN rail as follows:

1. Connect together a number of rear 5-pin MSCB plug connectors to suit the number of modules to be installed.
2. Fasten the row of plug connectors assembled in this manner to the DIN rail (first hook on at the top).
3. Fasten modules to the rail and during this process place the contacts on the base of the module over the related plug connector. Carefully push in module until it noticeably engages.
4. To remove the module, the catch on the rear of the module must be pulled down with the aid a screwdriver and the module lifted and pull off upward.

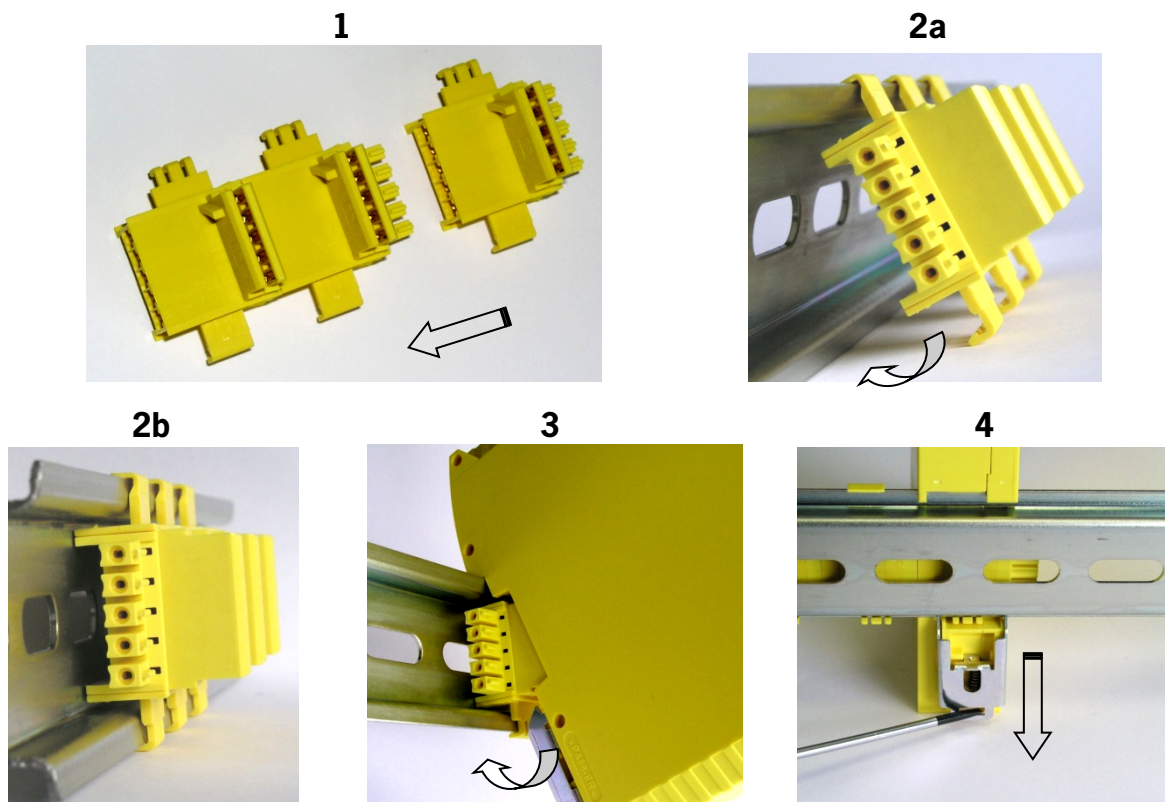

Figure 1: Fastening modules of the MSC system to a 35-mm DIN rail

5.2. Calculation of the safety distance for an item of ESPE connected to the MSC system

All electro-sensitive protective equipment that is connected to the MSC system must be arranged at a distance that is at least the minimum safety distance **S** such that the danger zone can be reached only after the machine's hazardous movement has stopped.



WARNING

- The European standard:
ISO 13855:2010- (EN 999:2008) *Safety of machinery – Positioning of safeguards with respect to the approach speeds of parts of the human body**
contains formulas for the calculation of the correct safety distance.
- Specific information in relation to the correct arrangement can be found in the installation instructions for each item of protective equipment.
- It is to be noted that the total reaction time is dependent on:
Reaction time of MSC + reaction time of ESPE + reaction time of the machine in seconds (i.e. the time the machine requires to stop the hazardous movement from the moment when the stop signal is sent).

* A procedure is described that permits system planners to determine the minimum safety distance between protective equipment, in particular ESPE (e.g. light grids), safety mats or pressure-sensitive floors and two-hand controls, and a specific danger zone. It contains a rule for the arrangement of protective equipment based on the approach speed and time taken by the machine to stop, where corresponding extrapolation is possible, such that interlocking devices without guard locking are also included.

5.3. Electrical connections

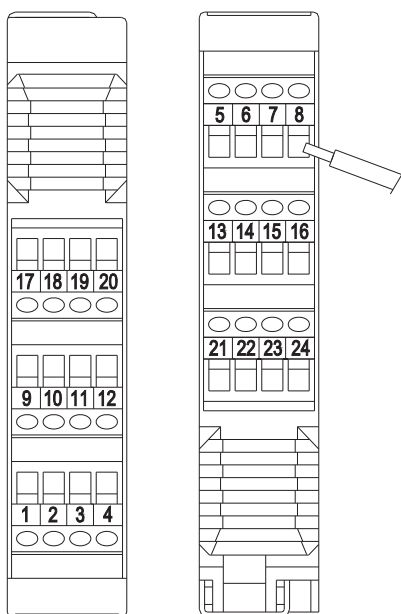

Figure 2: MSC terminal blocks

The modules of the MSC system are equipped with terminal blocks for the electrical connections. Each module can have 8, 16 or 24 terminals.

Each module also has an MSCB plug connector on the rear (for the communication with the base unit and the other extension modules).



Important!

Terminal tightening torque: 0.6–0.7 Nm



WARNING

- › Install safety modules in a housing that meets degree of protection IP54 as a minimum.
- › Connect module in electrically isolated state.
- › The power supply for the modules must be 24 VDC \pm 20% (PELV, as per EN 60204-1 (chapter 6.4)).
- › MSC is not allowed to be used to supply external devices.
- › The same ground connection (0 VDC) is to be used for all system components.

5.3.1. Notes in relation to connecting cables



NOTICE

- › Connection cross-section range: AWG 12–30 (single conductor/multiple conductor) (UL).
- › Use only copper conductors (Cu) for 60/75 °C.
- › It is recommended to use separate power supplies for the safety module and for other electrically powered devices (electric motors, inverters, frequency converters) or other sources of interference.
- › Cables for connections with a length of more than 50 m must have a cross-section of at least 1 mm² (AWG16).

5.3.2. Notes on 



Important!

- This device is intended to be used with a Class 2 power source.
As an alternative an LV/C (Limited Voltage/Current) power source with the following properties can be used:
This device shall be used with a suitable isolating source in conjunction with a fuse in accordance with UL248. The fuse shall be rated max. 3.3 A and be installed in the max. 30 V DC power supply to the device in order to limit the available current to comply with the UL requirements. Please note possibly lower connection ratings for your device (refer to the technical data).
- For use and application as per the requirements¹⁾, a connecting cable listed under the UL category code CYJV/7 must be used.

1) Note on the scope of the UL approval: the devices have been tested as per the requirements of UL508 and CSA/ C22.2 no. 14 (protection against electric shock and fire).

The connections for each module in the MSC system are listed in the tables below:

5.3.2.1. Base unit MSC-CB

TERMINAL	SIGNAL	TYPE	DESCRIPTION	VERSION
1	24 VDC	-	Power supply 24 VDC	-
2	MASTER_ENABLE1	Input	Base unit enable 1	Input (" type B " as per EN 61131-2)
3	MASTER_ENABLE2	Input	Base unit enable 2	Input (" type B " as per EN 61131-2)
4	GND	-	Power supply 0 VDC	-
5	OSSD1_A	Output	Safety output 1	PNP Active High
6	OSSD1_B	Output		PNP Active High
7	RESTART_FBK1	Input	Feedback loop/restart 1	Input as per EN 61131-2
8	OUT_STATUS1	Output	Programmable digital output	PNP Active High
9	OSSD2_A	Output	Safety output 2	PNP Active High
10	OSSD2_B	Output		PNP Active High
11	RESTART_FBK2	Input	Feedback loop/restart 2	Input as per EN 61131-2
12	OUT_STATUS2	Output	Programmable digital output	PNP Active High
13	OUT_TEST1	Output	Output for short circuit detection	PNP Active High
14	OUT_TEST2	Output	Output for short circuit detection	PNP Active High
15	OUT_TEST3	Output	Output for short circuit detection	PNP Active High
16	OUT_TEST4	Output	Output for short circuit detection	PNP Active High
17	INPUT1	Input	Digital input 1	Input as per EN 61131-2
18	INPUT2	Input	Digital input 2	Input as per EN 61131-2
19	INPUT3	Input	Digital input 3	Input as per EN 61131-2
20	INPUT4	Input	Digital input 4	Input as per EN 61131-2
21	INPUT5	Input	Digital input 5	Input as per EN 61131-2
22	INPUT6	Input	Digital input 6	Input as per EN 61131-2
23	INPUT7	Input	Digital input 7	Input as per EN 61131-2
24	INPUT8	Input	Digital input 8	Input as per EN 61131-2

Table 2: Base unit MSC-CB

5.3.2.2. Base unit MSC-CB-S

TERMINAL	SIGNAL	TYPE	DESCRIPTION	VERSION
1	24 VDC	-	Power supply 24 VDC	-
2	n.c.	-	-	-
3	n.c.	-	-	-
4	GND	-	Power supply 0 VDC	-
5	OSSD1	Output	Safety output 1	PNP Active High
6	OSSD2	Output	Safety output 2	PNP Active High
7	RESTART_FBK1/ STATUS1	Input/ output	Feedback loop/restart 1	Input as per EN 61131-2
			Programmable digital output	PNP Active High
8	RESTART_FBK2/ STATUS2	Input/ output	Feedback loop/restart 2	Input as per EN 61131-2
			Programmable digital output	PNP Active High
9	OSSD3	Output	Safety output 3	PNP Active High
10	OSSD4	Output	Safety output 4	PNP Active High
11	RESTART_FBK3/ STATUS3	Input/ output	Feedback loop/restart 3	Input as per EN 61131-2
			Programmable digital output	PNP Active High
12	RESTART_FBK4/ STATUS4	Input/ output	Feedback loop/restart 4	Input as per EN 61131-2
			Programmable digital output	PNP Active High
13	OUT_TEST1	Output	Output for short circuit detection	PNP Active High
14	OUT_TEST2	Output	Output for short circuit detection	PNP Active High
15	OUT_TEST3	Output	Output for short circuit detection	PNP Active High
16	OUT_TEST4	Output	Output for short circuit detection	PNP Active High
17	INPUT1	Input	Digital input 1	Input as per EN 61131-2
18	INPUT2	Input	Digital input 2	Input as per EN 61131-2
19	INPUT3	Input	Digital input 3	Input as per EN 61131-2
20	INPUT4	Input	Digital input 4	Input as per EN 61131-2
21	INPUT5	Input	Digital input 5	Input as per EN 61131-2
22	INPUT6	Input	Digital input 6	Input as per EN 61131-2
23	INPUT7	Input	Digital input 7	Input as per EN 61131-2
24	INPUT8	Input	Digital input 8	Input as per EN 61131-2

Table 3: Base unit MSC-CB-S



NOTICE

The terminals of the monitoring outputs (OUT_STATUS) are shared with the control inputs (RESTART_FBK) of the OSSD outputs. In order to be able to use the monitoring output, the corresponding OSSD output must be used with an automatic restart without external feedback loop monitoring. In order to be able to use the STATUS1 output (terminal 7), automatic restart without feedback loop monitoring must be set for OSSD1 in EUCHNER Safety Designer.

5.3.3. USB connection

The MSC base units have a USB 2.0 port for connection to a PC on which the EUCHNER Safety Designer configuration software (see figure) is installed.

A USB cable of appropriate size is available as an accessory.



Figure 3: Front USB-2.0 connection

5.3.4. MSC configuration memory (M-A1)

An optional backup memory card (called **M-A1**) can be installed in the MSC base unit for backing up the software configuration parameters.

Every new project transferred from the PC to MSC-CB/MSC-CB-S is written to the memory card M-A1.

➔ Always switch off MSC-CB/MSC-CB-S before logging onto or logging off from the M-A1.

Insert card into the **slot on the rear of the MSC-CB/MSC-CB-S** (direction as shown in *Figure 4: M-A1*).

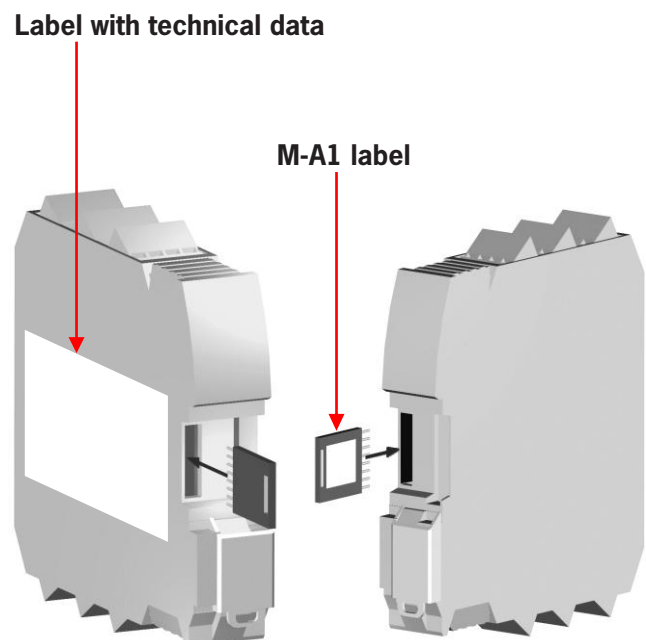

Figure 4: M-A1



NOTICE

- › The base unit MSC-CB-S can read configurations from MSC-CB-S and MSC-CB.
- › The base unit MSC-CB can read configurations only from MSC-CB.

5.3.4.1. MULTIPLE LOAD function

To configure several base units without using a PC and the USB port, the required configuration can be saved on an M-A1 memory card and then downloaded from there to the base units to be configured.



NOTICE

If the file on the memory card is not identical to the file in the MSC-CB/MSC-CB-S, the configuration data in the MSC-CB/MSC-CB-S will be overwritten and therefore permanently deleted.

WARNING: ALL DATA THAT WERE IN THE MSC-CB/MSC-CB-S WILL BE LOST.

5.3.4.2. RESTORE function

If the MSC-CB/MSC-CB-S module is faulty, it can be replaced with a new module. As the entire configuration is saved on the M-A1 memory card, all that is necessary is to insert this card in the new module and switch on the MSC system; the backed up configuration will then be loaded immediately. In this way interruptions in operation can be reduced to a minimum.



Important!

- The LOAD and RESTORE functions can be deactivated using the software (see *Figure 47: EUCHNER Safety Designer, selecting extension module on page 75*).
- The extension modules must be assigned addresses during installation before use (see NODE_SEL).



WARNING

Each time M-A1 is used, it is to be carefully checked whether the configuration selected is the configuration prepared for this specific system. A complete function check must be performed on the system comprising the MSC and all devices connected to it (see section “CHECKING the system” Page 89).

5.3.5. Module FI8FO2

TERMINAL	SIGNAL	TYPE	DESCRIPTION	ACTION
1	24 VDC	-	Power supply 24 VDC	-
2	NODE_SEL0	Input	Node selection	Input (“ type B ” as per EN 61131-2)
3	NODE_SEL1	Input		Input (“ type B ” as per EN 61131-2)
4	GND	-	Power supply 0 VDC	-
5	OSSD1_A	Output	Safety output 1	PNP Active High
6	OSSD1_B	Output		PNP Active High
7	RESTART_FBK1	Input	Feedback loop/restart 1	Input as per EN 61131-2
8	OUT_STATUS1	Output	Programmable digital output	PNP Active High
9	OSSD2_A	Output	Safety output 2	PNP Active High
10	OSSD2_B	Output		PNP Active High
11	RESTART_FBK2	Input	Feedback loop/restart 2	Input as per EN 61131-2
12	OUT_STATUS2	Output	Programmable digital output	PNP Active High
13	OUT_TEST1	Output	Output for short circuit detection	PNP Active High
14	OUT_TEST2	Output	Output for short circuit detection	PNP Active High
15	OUT_TEST3	Output	Output for short circuit detection	PNP Active High
16	OUT_TEST4	Output	Output for short circuit detection	PNP Active High
17	INPUT1	Input	Digital input 1	Input as per EN 61131-2
18	INPUT2	Input	Digital input 2	Input as per EN 61131-2
19	INPUT3	Input	Digital input 3	Input as per EN 61131-2
20	INPUT4	Input	Digital input 4	Input as per EN 61131-2
21	INPUT5	Input	Digital input 5	Input as per EN 61131-2
22	INPUT6	Input	Digital input 6	Input as per EN 61131-2
23	INPUT7	Input	Digital input 7	Input as per EN 61131-2
24	INPUT8	Input	Digital input 8	Input as per EN 61131-2

Table 4: Module FI8FO2

5.3.6. Module FI8F04S

TERMINAL	SIGNAL	TYPE	DESCRIPTION	VERSION
1	24 VDC	-	Power supply 24 VDC	-
2	NODE_SEL0	-	Node selection	Input (" type B " as per EN 61131-2)
3	NODE_SEL1	-	Node selection	Input (" type B " as per EN 61131-2)
4	GND	-	Power supply 0 VDC	-
5	OSSD1	Output	Safety output 1	PNP Active High
6	OSSD2	Output	Safety output 2	PNP Active High
7	RESTART_FBK1/ STATUS1	Input/ output	Feedback loop/restart 1	Input as per EN 61131-2
			Programmable digital output	PNP Active High
8	RESTART_FBK2/ STATUS2	Input/ output	Feedback loop/restart 2	Input as per EN 61131-2
			Programmable digital output	PNP Active High
9	OSSD3	Output	Safety output 3	PNP Active High
10	OSSD4	Output	Safety output 4	PNP Active High
11	RESTART_FBK3/ STATUS3	Input/ output	Feedback loop/restart 3	Input as per EN 61131-2
			Programmable digital output	PNP Active High
12	RESTART_FBK4/ STATUS4	Input/ output	Feedback loop/restart 4	Input as per EN 61131-2
			Programmable digital output	PNP Active High
13	OUT_TEST1	Output	Output for short circuit detection	PNP Active High
14	OUT_TEST2	Output	Output for short circuit detection	PNP Active High
15	OUT_TEST3	Output	Output for short circuit detection	PNP Active High
16	OUT_TEST4	Output	Output for short circuit detection	PNP Active High
17	INPUT1	Input	Digital input 1	Input as per EN 61131-2
18	INPUT2	Input	Digital input 2	Input as per EN 61131-2
19	INPUT3	Input	Digital input 3	Input as per EN 61131-2
20	INPUT4	Input	Digital input 4	Input as per EN 61131-2
21	INPUT5	Input	Digital input 5	Input as per EN 61131-2
22	INPUT6	Input	Digital input 6	Input as per EN 61131-2
23	INPUT7	Input	Digital input 7	Input as per EN 61131-2
24	INPUT8	Input	Digital input 8	Input as per EN 61131-2

Table 5: Module FI8F04S



NOTICE

The terminals of the monitoring outputs (OUT_STATUS) are shared with the control inputs (RESTART_FBK) of the OSSD outputs. In order to be able to use the monitoring output, the corresponding OSSD output must be used with an automatic restart without external feedback loop monitoring. In order to be able to use the STATUS1 output (terminal 7), automatic restart without feedback loop monitoring must be set for OSSD1 in EUCHNER Safety Designer.

5.3.7. Module FI8

TERMINAL	SIGNAL	TYPE	DESCRIPTION	VERSION
1	24 VDC	-	Power supply 24 VDC	-
2	NODE_SEL0	Input	Node selection	Input ("type B" as per EN 61131-2)
3	NODE_SEL1	Input		Input ("type B" as per EN 61131-2)
4	GND	-	Power supply 0 VDC	-
5	INPUT1	Input	Digital input 1	Input as per EN 61131-2
6	INPUT2	Input	Digital input 2	Input as per EN 61131-2
7	INPUT3	Input	Digital input 3	Input as per EN 61131-2
8	INPUT4	Input	Digital input 4	Input as per EN 61131-2
9	OUT_TEST1	Output	Output for short circuit detection	PNP Active High
10	OUT_TEST2	Output	Output for short circuit detection	PNP Active High
11	OUT_TEST3	Output	Output for short circuit detection	PNP Active High
12	OUT_TEST4	Output	Output for short circuit detection	PNP Active High
13	INPUT5	Input	Digital input 5	Input as per EN 61131-2
14	INPUT6	Input	Digital input 6	Input as per EN 61131-2
15	INPUT7	Input	Digital input 7	Input as per EN 61131-2
16	INPUT8	Input	Digital input 8	Input as per EN 61131-2

Table 6: Module FI8

5.3.8. Module FM4

TERMINAL	SIGNAL	TYPE	DESCRIPTION	VERSION
1	24 VDC	-	Power supply 24 VDC	-
2	NODE_SEL0	Input	Node selection	Input ("type B" as per EN 61131-2)
3	NODE_SEL1	Input		Input ("type B" as per EN 61131-2)
4	GND	-	Power supply 0 VDC	-
5	INPUT1	Input	Digital input 1	Input as per EN 61131-2
6	INPUT2	Input	Digital input 2	Input as per EN 61131-2
7	INPUT3	Input	Digital input 3	Input as per EN 61131-2
8	INPUT4	Input	Digital input 4	Input as per EN 61131-2
9	OUT_TEST1	Output	Output for short circuit detection	PNP Active High
10	OUT_TEST2	Output	Output for short circuit detection	PNP Active High
11	OUT_TEST3	Output	Output for short circuit detection	PNP Active High
12	OUT_TEST4	Output	Output for short circuit detection	PNP Active High
13	INPUT5	Input	Digital input 5	Input as per EN 61131-2
14	INPUT6	Input	Digital input 6	Input as per EN 61131-2
15	INPUT7	Input	Digital input 7	Input as per EN 61131-2
16	INPUT8	Input	Digital input 8	Input as per EN 61131-2
17	OUT_TEST5	Output	Output for short circuit detection	PNP Active High
18	OUT_TEST6	Output	Output for short circuit detection	PNP Active High
19	OUT_TEST7	Output	Output for short circuit detection	PNP Active High
20	OUT_TEST8	Output	Output for short circuit detection	PNP Active High
21	INPUT9	Input	Digital input 9	Input as per EN 61131-2
22	INPUT10	Input	Digital input 10	Input as per EN 61131-2
23	INPUT11	Input	Digital input 11	Input as per EN 61131-2
24	INPUT12	Input	Digital input 12	Input as per EN 61131-2

Table 7: Module FM4

5.3.9. Module FI16

TERMINAL	SIGNAL	TYPE	DESCRIPTION	VERSION
1	24 VDC	-	Power supply 24 VDC	-
2	NODE_SEL0	Input	Node selection	Input (" type B " as per EN 61131-2)
3	NODE_SEL1	Input		Input (" type B " as per EN 61131-2)
4	GND	-	Power supply 0 VDC	-
5	INPUT1	Input	Digital input 1	Input as per EN 61131-2
6	INPUT2	Input	Digital input 2	Input as per EN 61131-2
7	INPUT3	Input	Digital input 3	Input as per EN 61131-2
8	INPUT4	Input	Digital input 4	Input as per EN 61131-2
9	OUT_TEST1	Output	Output for short circuit detection	PNP Active High
10	OUT_TEST2	Output	Output for short circuit detection	PNP Active High
11	OUT_TEST3	Output	Output for short circuit detection	PNP Active High
12	OUT_TEST4	Output	Output for short circuit detection	PNP Active High
13	INPUT5	Input	Digital input 5	Input as per EN 61131-2
14	INPUT6	Input	Digital input 6	Input as per EN 61131-2
15	INPUT7	Input	Digital input 7	Input as per EN 61131-2
16	INPUT8	Input	Digital input 8	Input as per EN 61131-2
17	INPUT9	Output	Digital input 9	Input as per EN 61131-2
18	INPUT10	Output	Digital input 10	Input as per EN 61131-2
19	INPUT11	Output	Digital input 11	Input as per EN 61131-2
20	INPUT12	Output	Digital input 12	Input as per EN 61131-2
21	INPUT13	Input	Digital input 13	Input as per EN 61131-2
22	INPUT14	Input	Digital input 14	Input as per EN 61131-2
23	INPUT15	Input	Digital input 15	Input as per EN 61131-2
24	INPUT16	Input	Digital input 16	Input as per EN 61131-2

Table 8: Module FI16

5.3.10. Module AC-F04

TERMINAL	SIGNAL	TYPE	DESCRIPTION	VERSION
1	24 VDC	-	Power supply 24 VDC	-
2	NODE_SELO	Input	Node selection	Input ("type B" as per EN 61131-2)
3	NODE_SEL1	Input		Input ("type B" as per EN 61131-2)
4	GND	-	Power supply 0 VDC	-
5	OSSD1_A	Output	Safety output 1	PNP Active High
6	OSSD1_B	Output		PNP Active High
7	RESTART_FBK1	Input	Feedback loop/restart 1	Input as per EN 61131-2
8	OUT_STATUS1	Output	Programmable digital output	PNP Active High
9	OSSD2_A	Output	Safety output 2	PNP Active High
10	OSSD2_B	Output		PNP Active High
11	RESTART_FBK2	Input	Feedback loop/restart 2	Input as per EN 61131-2
12	OUT_STATUS2	Output	Programmable digital output	PNP Active High
13	24 VDC	-	Power supply 24 VDC	24 VDC outputs, power supply*
14	24 VDC	-		
15	GND	-	Power supply 0 VDC	0 VDC outputs*
16	GND	-		
17	OSSD4_A	Output	Safety output 4	PNP Active High
18	OSSD4_B	Output		PNP Active High
19	RESTART_FBK4	Input	Feedback loop/restart 4	Input as per EN 61131-2
20	OUT_STATUS4	Output	Programmable digital output	PNP Active High
21	OSSD3_A	Output	Safety output 3	PNP Active High
22	OSSD3_B	Output		PNP Active High
23	RESTART_FBK3	Input	Feedback loop/restart 3	Input as per EN 61131-2
24	OUT_STATUS3	Output	Programmable digital output	PNP Active High

Table 9: Module AC-F04

5.3.11. Module AC-F02

TERMINAL	SIGNAL	TYPE	DESCRIPTION	VERSION
1	24 VDC	-	Power supply 24 VDC	-
2	NODE_SELO	Input	Node selection	Input ("type B" as per EN 61131-2)
3	NODE_SEL1	Input		Input ("type B" as per EN 61131-2)
4	GND	-	Power supply 0 VDC	-
5	OSSD1_A	Output	Safety output 1	PNP Active High
6	OSSD1_B	Output		PNP Active High
7	RESTART_FBK1	Input	Feedback loop/restart 1	Input as per EN 61131-2
8	OUT_STATUS1	Output	State of the outputs 1A/1B	PNP Active High
9	OSSD2_A	Output	Safety output 2	PNP Active High
10	OSSD2_B	Output		PNP Active High
11	RESTART_FBK2	Input	Feedback loop/restart 2	Input as per EN 61131-2
12	OUT_STATUS2	Output	State of the outputs 2A/2B	PNP Active High
13	24 VDC	-	Power supply 24 VDC	24 VDC output, power supply*
14	n.c.	-	-	-
15	GND	-	Power supply 0 VDC	0 VDC output*
16	n.c.	-	-	-

Table 10: Module AC-F02

* This terminal must be connected to the power supply so that the module functions correctly.

5.3.12. Modules SPM0 – SPM1 – SPM2

TERMINAL	SIGNAL	TYPE	DESCRIPTION	VERSION
1	24 VDC	-	Power supply 24 VDC	-
2	NODE_SELO	Input	Node selection	Input (" type B " as per EN 61131-2)
3	NODE_SEL1	Input		
4	GND	-		
5	PROXI1_24V	Output	Connections of the 1st proximity switch (see Page 32)	Power supply 24 VDC on PROXI1
6	PROXI1_REF	Output		Power supply 0 VDC on PROXI1
7	PROXI1 IN1 (3 WIRES)	Input		PROXI1 NO contact
8	PROXI1 IN2 (4 WIRES)	Input		PROXI1 NC contact
9	PROXI2_24 V	Output	Connections of the 2nd proximity switch (see Page 32)	Power supply 24 VDC on PROXI2
10	PROXI2_REF	Output		Power supply 0 VDC on PROXI2
11	PROXI2 IN1 (3 WIRES)	Input		PROXI2 NO contact
12	PROXI2 IN2 (4 WIRES)	Input		PROXI2 NC contact
13	n.c.	-	Not connected	-
14	n.c.	-		
15	n.c.	-		
16	n.c.	-		

Table 11: Modules SPM0 – SPM1 – SPM2

5.3.12.1. Encoder connections with RJ45 plug connector (SPM1, SPM2)

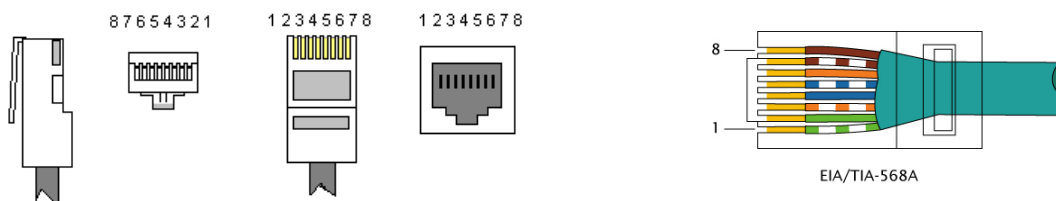

	PIN		SPMTB	SPMH	SPMS
TWISTED *	1	INPUT	n.c.	n.c.	n.c.
	2		GND	GND	GND
	3		n.c.	n.c.	n.c.
TWISTED *	4		A	A	A
	5		\bar{A}	\bar{A}	\bar{A}
TWISTED *	6		n.c.	n.c.	n.c.
	7		B	B	B
	8		\bar{B}	\bar{B}	\bar{B}

* If twisted-pair cables are used.

Table 12: Pin assignment

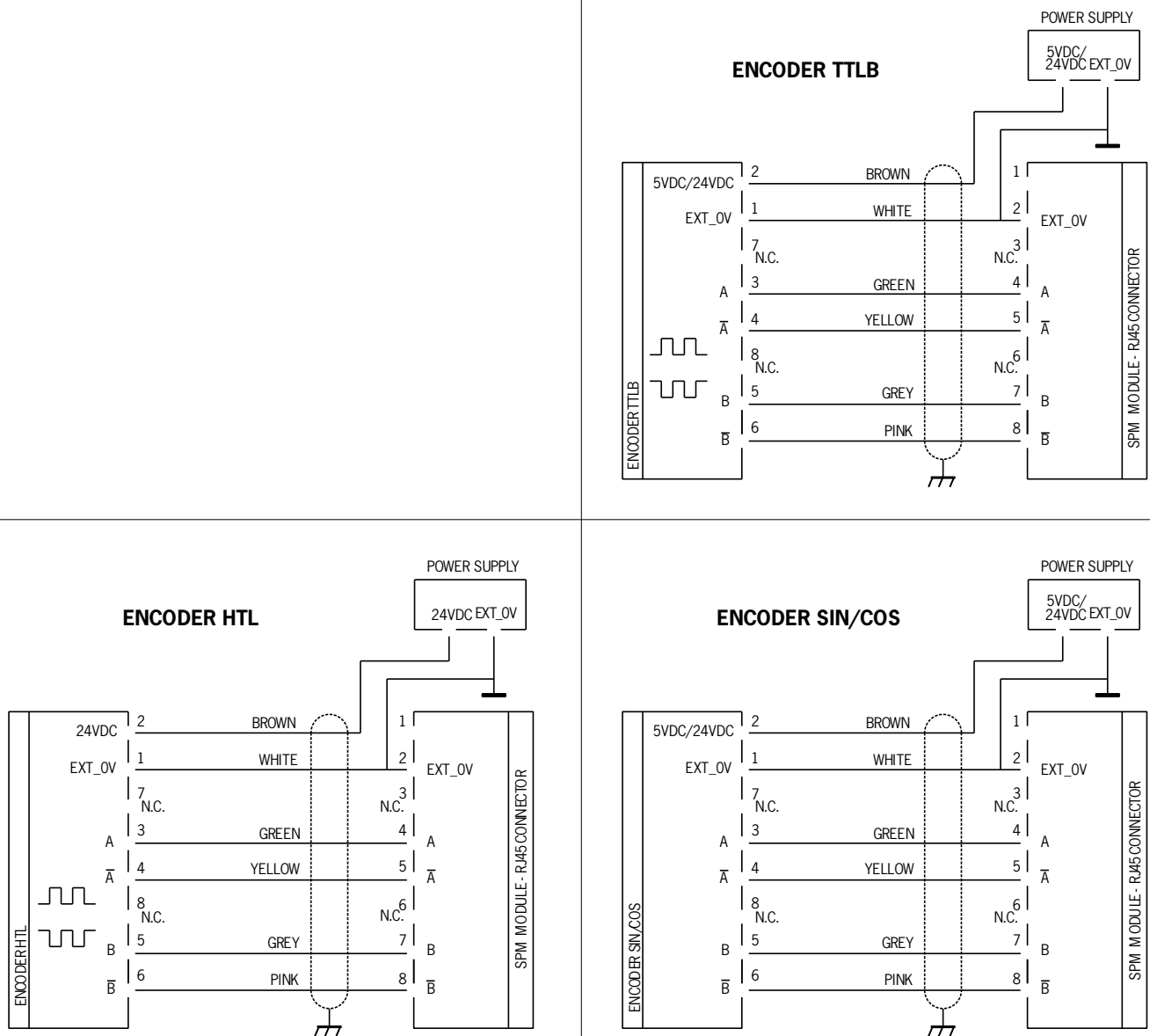

Figure 5: Connection examples

5.3.13. Module AZ-F04

TERMINAL	SIGNAL	TYPE	DESCRIPTION	VERSION
1	24 VDC	-	Power supply 24 VDC	-
2	NODE_SEL0	Input	Node selection	Input ("type B" as per EN 61131-2)
3	NODE_SEL1	Input		Input ("type B" as per EN 61131-2)
4	GND	-	Power supply 0 VDC	-
5	REST_FBK1	Input	Feedback loop/restart 1	Input as per EN 61131-2
6	REST_FBK2	Input	Feedback loop/restart 2	Input as per EN 61131-2
7	REST_FBK3	Input	Feedback loop/restart 3	Input as per EN 61131-2
8	REST_FBK4	Input	Feedback loop/restart 4	Input as per EN 61131-2
9	A_NO1	Output	Normally open contact, channel 1	
10	B_NO1	Output		
11	A_NO2	Output	Normally open contact, channel 2	
12	B_NO2	Output		
13	A_NO3	Output	Normally open contact, channel 3	
14	B_NO3	Output		
15	A_NO4	Output	Normally open contact, channel 4	
16	B_NO4	Output		

Table 13: Module AZ-F04

5.3.14. Module AZ-F0408

TERMINAL	SIGNAL	TYPE	DESCRIPTION	VERSION
1	24 VDC	-	Power supply 24 VDC	-
2	NODE_SEL0	Input	Node selection	Input ("type B" as per EN 61131-2)
3	NODE_SEL1	Input		Input ("type B" as per EN 61131-2)
4	GND	-	Power supply 0 VDC	-
5	REST_FBK1	Input	Feedback loop/restart 1	Input as per EN 61131-2
6	REST_FBK2	Input	Feedback loop/restart 2	Input as per EN 61131-2
7	REST_FBK3	Input	Feedback loop/restart 3	Input as per EN 61131-2
8	REST_FBK4	Input	Feedback loop/restart 4	Input as per EN 61131-2
9	A_NO1	Output	Normally open contact, channel 1	
10	B_NO1	Output		
11	A_NO2	Output	Normally open contact, channel 2	
12	B_NO2	Output		
13	A_NO3	Output	Normally open contact, channel 3	
14	B_NO3	Output		
15	A_NO4	Output	Normally open contact, channel 4	
16	B_NO4	Output		
17	SYS_STATUS1	Output	Programmable digital output 1	PNP Active High
18	SYS_STATUS2	Output	Programmable digital output 2	PNP Active High
19	SYS_STATUS3	Output	Programmable digital output 3	PNP Active High
20	SYS_STATUS4	Output	Programmable digital output 4	PNP Active High
21	SYS_STATUS5	Output	Programmable digital output 5	PNP Active High
22	SYS_STATUS6	Output	Programmable digital output 6	PNP Active High
23	SYS_STATUS7	Output	Programmable digital output 7	PNP Active High
24	SYS_STATUS8	Output	Programmable digital output 8	PNP Active High

Table 14: Module AZ-F0408

5.3.15. Module O8

PIN	SIGNAL	TYPE	DESCRIPTION	VERSION
1	24 VDC	-	Power supply 24 VDC	-
2	NODE_SELO	Input	Node selection	Input (" type B " as per EN 61131-2)
3	NODE_SEL1	Input		Input (" type B " as per EN 61131-2)
4	GND	-	Power supply 0 VDC	-
5	24 VDC STATUS 1-8	-	Power supply 24 VDC Monitoring outputs 1-8	-
6	-	-	-	-
7	-	-	-	-
8	-	-	-	-
9	SYS_STATUS1	Output	Programmable digital output 1	PNP Active High
10	SYS_STATUS2	Output	Programmable digital output 2	PNP Active High
11	SYS_STATUS3	Output	Programmable digital output 3	PNP Active High
12	SYS_STATUS4	Output	Programmable digital output 4	PNP Active High
13	SYS_STATUS5	Output	Programmable digital output 5	PNP Active High
14	SYS_STATUS6	Output	Programmable digital output 6	PNP Active High
15	SYS_STATUS7	Output	Programmable digital output 7	PNP Active High
16	SYS_STATUS8	Output	Programmable digital output 8	PNP Active High

Table 15: Module O8

5.3.16. Module O16

PIN	SIGNAL	TYPE	DESCRIPTION	VERSION
1	24 VDC	-	Power supply 24 VDC	-
2	NODE_SELO	Input	Node selection	Input (" type B " as per EN 61131-2)
3	NODE_SEL1	Input		Input (" type B " as per EN 61131-2)
4	GND	-	Power supply 0 VDC	-
5	24 VDC STATUS 1-8	-	Power supply 24 VDC Programmable digital outputs 1-8	-
6	24 VDC STATUS 9-16	-	Power supply 24 VDC Programmable digital outputs 9-16	-
7	-	-	-	-
8	-	-	-	-
9	SYS_STATUS1	Output	Programmable digital output 1	PNP Active High
10	SYS_STATUS2	Output	Programmable digital output 2	PNP Active High
11	SYS_STATUS3	Output	Programmable digital output 3	PNP Active High
12	SYS_STATUS4	Output	Programmable digital output 4	PNP Active High
13	SYS_STATUS5	Output	Programmable digital output 5	PNP Active High
14	SYS_STATUS6	Output	Programmable digital output 6	PNP Active High
15	SYS_STATUS7	Output	Programmable digital output 7	PNP Active High
16	SYS_STATUS8	Output	Programmable digital output 8	PNP Active High
17	SYS_STATUS9	Output	Programmable digital output 9	PNP Active High
18	SYS_STATUS10	Output	Programmable digital output 10	PNP Active High
19	SYS_STATUS11	Output	Programmable digital output 11	PNP Active High
20	SYS_STATUS12	Output	Programmable digital output 12	PNP Active High
21	SYS_STATUS13	Output	Programmable digital output 13	PNP Active High
22	SYS_STATUS14	Output	Programmable digital output 14	PNP Active High
23	SYS_STATUS15	Output	Programmable digital output 15	PNP Active High
24	SYS_STATUS16	Output	Programmable digital output 16	PNP Active High

Table 16: Module O16

5.3.17. Module AH-F04S08

PIN	SIGNAL	TYPE	DESCRIPTION	VERSION
1	24 VDC	-	Power supply 24 VDC	-
2	NODE_SEL0	Input	Node selection	Input ("type B" as per EN 61131-2)
3	NODE_SEL1	Input		Input ("type B" as per EN 61131-2)
4	GND	-	Power supply 0 VDC	-
5	REST_FBK1	Input	Feedback loop/restart 1	Input as per EN 61131-2
6	REST_FBK2	Input	Feedback loop/restart 2	Input as per EN 61131-2
7	REST_FBK3	Input	Feedback loop/restart 3	Input as per EN 61131-2
8	REST_FBK4	Input	Feedback loop/restart 4	Input as per EN 61131-2
9	OSSD1	Output	Safety output 1	PNP Active High Four single-channel (or two dual-channel)
10	OSSD2	Output	Safety output 2	
11	OSSD3	Output	Safety output 3	
12	OSSD4	Output	Safety output 4	
13	-	-	-	-
14	24 VDC	-	Power supply 24 VDC	-
15	-	-	-	-
16	-	-	-	-
17	SYS_STATUS1	Output	Programmable digital output 1	PNP Active High
18	SYS_STATUS2	Output	Programmable digital output 2	PNP Active High
19	SYS_STATUS3	Output	Programmable digital output 3	PNP Active High
20	SYS_STATUS4	Output	Programmable digital output 4	PNP Active High
21	SYS_STATUS5	Output	Programmable digital output 5	PNP Active High
22	SYS_STATUS6	Output	Programmable digital output 6	PNP Active High
23	SYS_STATUS7	Output	Programmable digital output 7	PNP Active High
24	SYS_STATUS8	Output	Programmable digital output 8	PNP Active High

Table 17: Module AH-F04S08

5.3.18. Example for the connection of the MSC system to the machine control

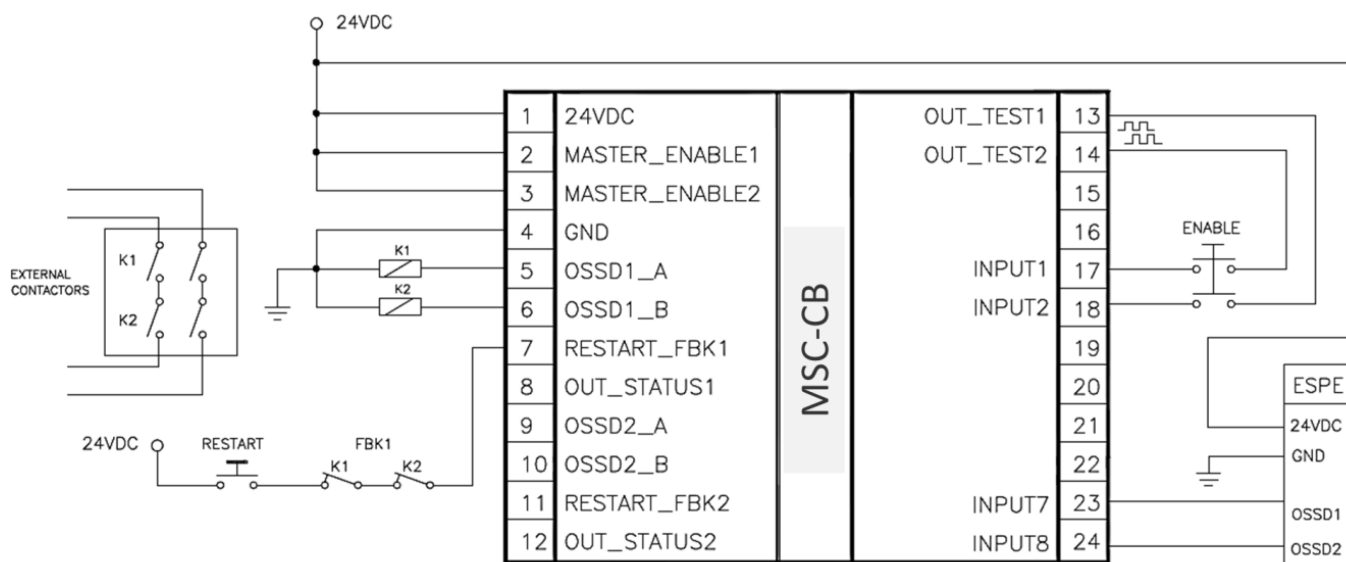

Figure 6: Example for the connection of the MSC system to the machine control

5.4. Checklist after installation

With the MSC system, faults can be detected in the individual modules. To ensure trouble-free operation of the system, the following checks are to be performed during setup and at least once a year:

1. Perform a complete system CHECK (see "CHECKING the system")
2. Check whether all cables are inserted correctly and the terminal blocks are tightened properly.
3. Check whether all LEDs (indicators) light up correctly.
4. Check whether all sensors connected to the MSC system are positioned correctly.
5. Check whether the MSC system is properly fastened to the DIN rail.
6. Check whether all external indicators (lamps) function correctly.



WARNING

After installation, maintenance or changing the configuration, perform the system CHECK as described in section "CHECKING the system" on page Page 89.

6. Flow chart

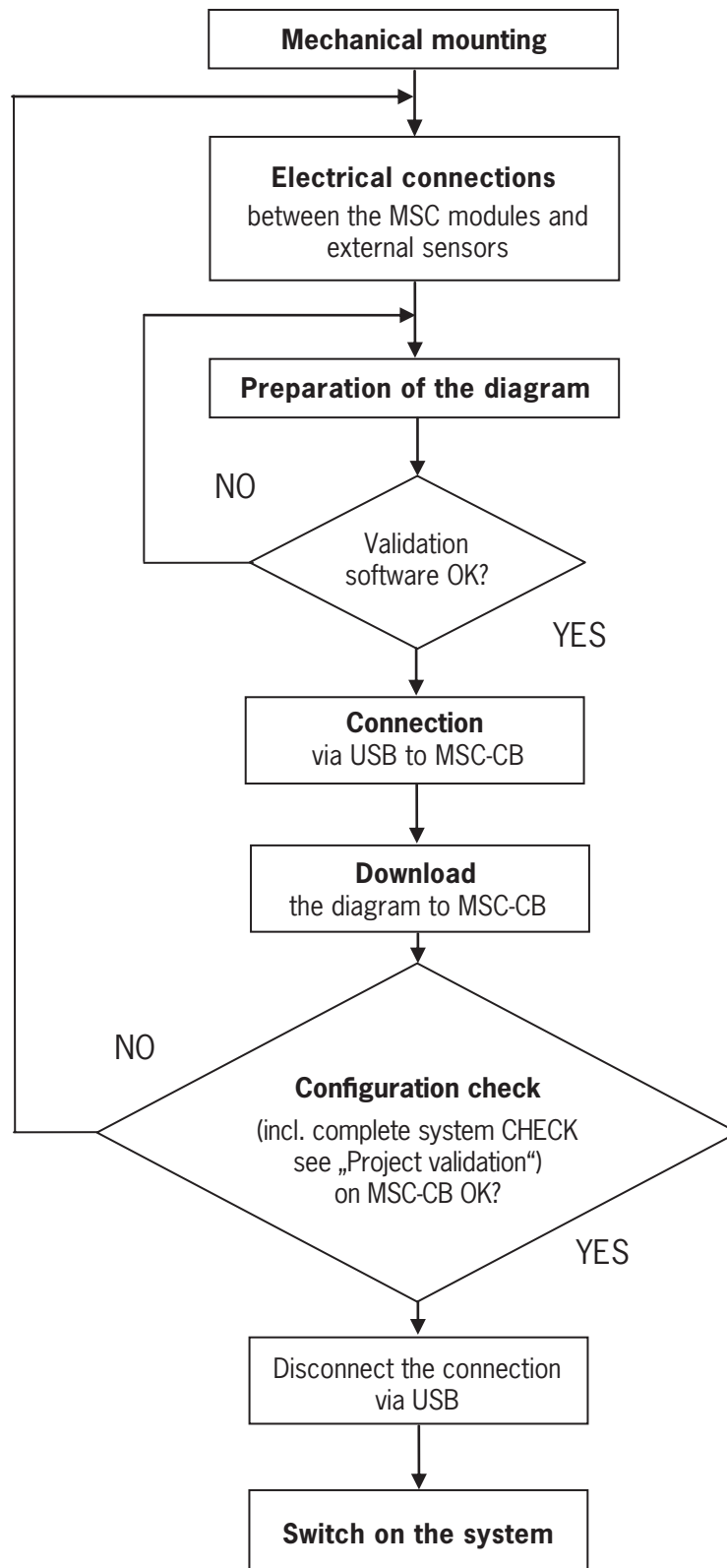

Figure 7: Flow chart

7. Signals

7.1. Inputs

7.1.1. MASTER_ENABLE

The base unit MSC-CB features two inputs: MASTER_ENABLE1 and MASTER_ENABLE2.



NOTICE

- These signals must both be set permanently to logic level 1 (24 VDC) so that the MSC system functions correctly. If you want to deactivate the MSC system, these inputs can be simply set to logic level 0 (0 VDC).
- The MSC system is always active on MSC-CB-S. MASTER_ENABLE is not present.

7.1.2. NODE_SEL

The inputs NODE_SEL0 and NODE_SEL1 (on the extension modules) are used to assign an address to the extension modules using the connections given in *Table 18*:

	NODE_SEL1 (TERMINAL 3)	NODE_SEL0 (TERMINAL 2)
NODE 0	0 (or not connected)	0 (or not connected)
NODE 1	0 (or not connected)	24 VDC
NODE 2	24 VDC	0 (or not connected)
NODE 3	24 VDC	24 VDC

Table 18: Node selection

A maximum of 4 addresses and therefore 4 modules of the same type are intended to be used in the same system.



NOTICE

Two modules of the same type are not allowed to be assigned the same physical address.

7.1.3. Proximity switch input on speed monitoring modules SPM

Configuration with combined proximity switches on one axis (Figure 8)

The SPM module can be configured in the “Combined proximity switch” mode for a measurement using two proximity switches on one axis.

The Performance Level PL e can be achieved under the following conditions:

- ➔ The proximity switches must be mounted such that the signals produced overlap.
- ➔ The proximity switches must be mounted such that at least one proximity switch is always actuated (active).

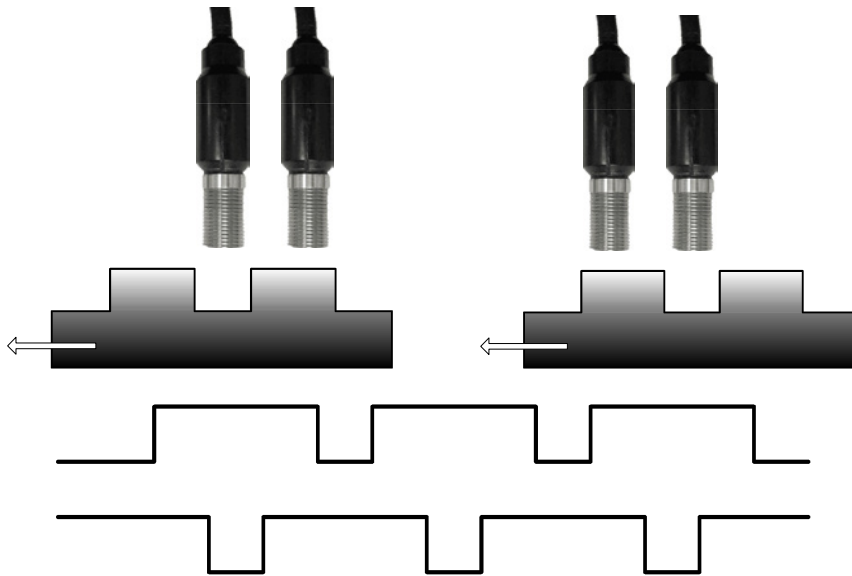

Figure 8: Proximity switches

Additional information:

- ➔ Proximity switches with a PNP output must be used.
- ➔ Proximity switches with a normally open output (NO, output active if switch actuated) must be used.
- ➔ In the conditions stated above the DC value is 90%
- ➔ Both proximity switches must be of the same type with a MTTF > 70 years.

7.1.4. RESTART_FBK

Using the RESTART_FBK signal, MSC can monitor a feedback loop signal (External Device Monitoring – EDM) from external contactors; both manual and automatic forms of starting can be programmed (see list of the possible connections in *Table 19*).



WARNING

- › If necessary, the response time of contactors must be checked using an additional device.
- › The command switch for starting (RESTART) must be installed outside the danger zone in a place from which there is a clear view of the danger zone and the entire working area affected.
- › It must not be possible to actuate the command switch from inside the danger zone.

Each OSSD pair has a corresponding RESTART_FBK input.

OPERATING MODE	EDM	RESTART_FBK
AUTOMATIC	With K1_K2 control	
	Without K1_K2 control	
MANUAL	With K1_K2 control	
	Without K1_K2 control	

Table 19: Restart_FBK configuration

7.2. Outputs

7.2.1. OUT_STATUS

The signal OUT_STATUS is a programmable digital output for the indication of the state of:

- › An input
- › An output
- › A node on the logic diagram designed with the aid of EUCHNER Safety Designer.

7.2.2. OUT_TEST

The inputs and the cables can be monitored for short circuits or overload states using the OUT_TEST signals (Figure 9).

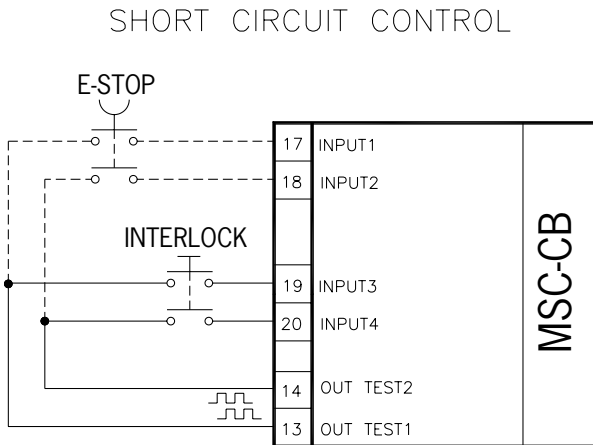

- ➔ The maximum number of inputs that can be controlled by each OUT_TEST output is as follows:
 - 4 INPUTS (parallel connection)
(MSC-CB, MSC-CB-S, FI8FO2, FI8FO4S, FI8, FM4, FI16)
- ➔ The maximum permissible length of the cable on the OUT_TEST output is 100 m.

Figure 9: OUT_TEST

7.2.3. OSSD

The modules MSC-CB, MSC-CB-S, FI8FO2, FI8FO4S, AC-FO2, AC-FO4 and AH-FO4S08 have OSSD (output signal switching device) outputs. These outputs are short circuit-proof, monitored for short circuits, and supply:

- › In the ON state: **$U_V - 0.75\text{ V}$ to U_V** (with $U_V = 24\text{ V} \pm 20\%$)
- › In the OFF state: **0 to 2 V rms.**

The maximum load of 400 mA at 24 V corresponds to a minimum ohmic load of 60 Ω .

The maximum capacitive load is 0.82 μF , and the maximum inductive load is 2 mH.

7.2.3.1. Single-channel OSSDs (MSC-CB-S, FI8FO4S, AH-FO4S08)

The modules MSC-CB-S, FI8FO4S and AH-FO4S08 have single-channel instead of dual-channel OSSD outputs. Three settings are available for the outputs (configuration via the EUCHNER Safety Designer software):

- › 4 single-channel outputs (1 safety output per channel with corresponding RESTART_FBK input)
- › 2 dual-channel outputs (2 safety outputs per channel with corresponding RESTART_FBK input)
- › 1 dual-channel output and 2 single-channel outputs



NOTICE

In order to meet the requirements of Safety Integrity Level (SIL) 3 when the single-channel OSSD outputs are used, the OSSD outputs must be mutually independent.



NOTICE

The most common causes of errors between the OSSD outputs must be ruled out by installing the cables properly (e.g. in separate cable paths).

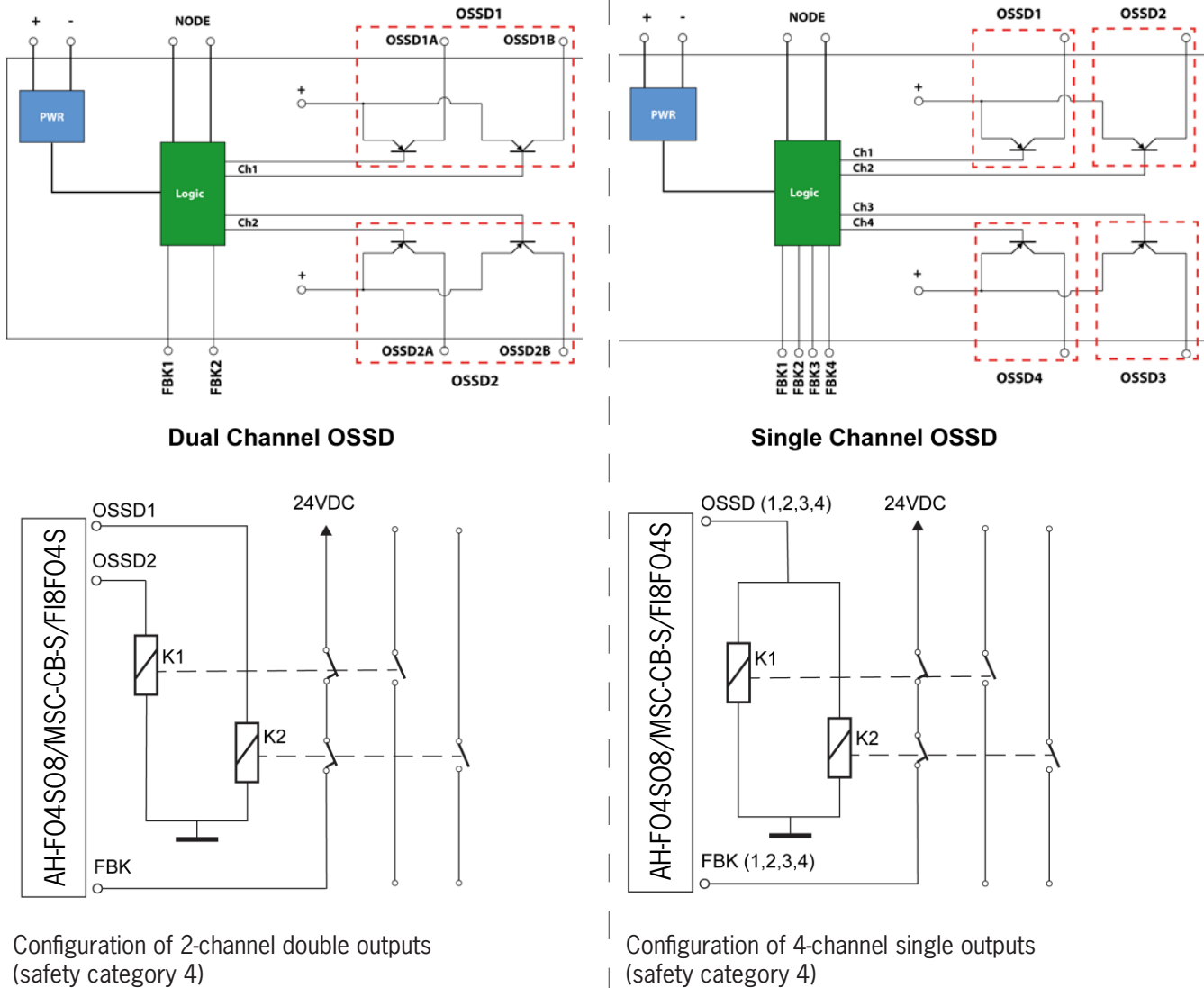

Figure 10: AH-FO4S08/MSC-CB-S/FI8FO4S

Each OSSD output can be configured as shown in Table 20:

Automatic	The output is activated, as per the configuration defined by the EUCHNER Safety Designer software, only if 24 VDC is applied to the related input RESTART_FBK.
Manual	The output is activated, as per the configuration defined by the EUCHNER Safety Designer software, only if there is the logical transition 0-->1 on the related input RESTART_FBK.
Monitored	The output is activated, as per the configuration defined by the EUCHNER Safety Designer software, only if there is the logical transition 0-->1-->0 on the related input RESTART_FBK.

Table 20: OSSD output configuration



Figure 11: Manual/monitored restart

7.2.3.2. High current OSSD (AH-F04S08)

The module AH-F04S08 has 4 high-current safety outputs (max. 2 A per channel).

- ➔ On the use of the module AH-F04S08 with output current > 500 mA, the module must be separated from the neighboring modules by the connection of an MSC plug connector in between.



NOTICE

It is not allowed to connect external devices to the outputs, except if this arrangement is intended in the configuration performed in the EUCHNER Safety Designer software.

7.2.4. Safety relays (AZ-F04, AZ-F0408)

Characteristics of the output circuit

The modules **AZ-F04/AZ-F0408** have safety relays with positively driven contacts with 1 normally open contact and 1 normally closed feedback loop contact. The modules **AZ-F04/AZ-F0408** contain 4 safety relays.



Important!

- ➔ You will find the possible operating modes for the modules AZ-F04/AZ-F0408 that can be configured using the EUCHNER SAFETY DESIGNER software in the section "Relay [RELAY]."

Excitation voltage	17–31 VDC
Switching voltage, min.	10 VDC
Switching current, min.	20 mA
Switching voltage, max. (DC)	250 VDC
Switching voltage, max. (AC)	400 VAC
Switching current, max.	6 A
Response time	12 ms
Mechanical life of contacts	> 20 x 10 ⁶

Table 21: Technical data for AZ-F04/AZ-F0408



NOTICE

To ensure correct isolation and to prevent the risk of premature aging or damage to the relay, each output cable is to be protected using a 4 A quick-blow fuse. In addition, the load characteristics must correspond to the information in *Table 21*.

8. Technical data

8.1. General system settings

8.1.1. Safety-related parameters

Parameters	Value	Standard
PFH _D	See tables with technical data for the related module	EN IEC 61508:2010
SIL	3 (Safe outputs and relay outputs)	
	1 (Digital outputs)	
SFF	99.80%	
HFT	1	
Safety standard	Type B	
SILCL	3	EN IEC 62061:2005
TYPE	4	EN IEC 61496-1:2013
PL	e (Safe outputs and relay outputs)	EN ISO 13849-1 EN IEC 62061:2005
	c (Digital outputs)	
DC _{avg}	High	
MTTF _D (years)	30–100	
Category	4	
Device mechanical life	20 years	
Degree of contamination	2	

8.1.2. General data

	MSC-CB	MSC-CB-S
Number of inputs, max.	128	
Number of safe dual-channel outputs, max.	16	30
Number of safe single-channel outputs, max.	12	32
Number of digital outputs, max.	32	48
Number of relay outputs, max.	12	28
OSSD (MSC-CB, MSC-CB-S, FI8FO2, FI8FO4S, AC-FO2, AC-FO4)	PNP Active High – 400 mA at 24 V DC max. (per OSSD)	
OSSD (AH-FO4SO8)	PNP Active High – 2 A at 24 V DC max. (per OSSD)	
Relay outputs (AZ-FO4, AZ-FO4O8)	6 A at 24 V DC max. (per relay)	
Response time MSC-CB (ms) This response time is dependent on the following parameters: 1) Number of extension modules installed 2) Number of operators 3) Number of OSSD outputs The correct response time is calculated by the EUCHNER Safety Designer software (see project report). Fault reaction time MSC-CB (ms) The fault reaction time corresponds to the reaction time, except on SPM modules with an encoder/proximity switch interface. In this case, the fault reaction time is 2 s.	Base unit	10.6–12.6 + T _{Input_filter}
	MSC-CB + 1 extension module	11.8–26.5 + T _{Input_filter}
	MSC-CB + 2 extension modules	12.8–28.7 + T _{Input_filter}
	MSC-CB + 3 extension modules	13.9–30.8 + T _{Input_filter}
	MSC-CB + 4 extension modules	15.0–33.0 + T _{Input_filter}
	MSC-CB + 5 extension modules	16.0–35.0 + T _{Input_filter}
	MSC-CB + 6 extension modules	17.0–37.3 + T _{Input_filter}
	MSC-CB + 7 extension modules	18.2–39.5 + T _{Input_filter}
	MSC-CB + 8 extension modules	19.3–41.7 + T _{Input_filter}
	MSC-CB + 9 extension modules	20.4–43.8 + T _{Input_filter}
	MSC-CB + 10 extension modules	21.5–46.0 + T _{Input_filter}
	MSC-CB + 11 extension modules	22.5–48.1 + T _{Input_filter}
	MSC-CB + 12 extension modules	23.6–50.3 + T _{Input_filter}
	MSC-CB + 13 extension modules	24.7–52.5 + T _{Input_filter}
MSC-CB + 14 extension modules	25.8–54.6 + T _{Input_filter}	

<p>Response time MSC-CB-S (ms)</p> <p>This response time is dependent on the following parameters:</p> <p>1) Number of extension modules installed 2) Number of operators 3) Number of OSSD outputs</p> <p>The correct response time is calculated by the EUCHNER Safety Designer software (see project report).</p> <p>Fault reaction time MSC-CB-S (ms)</p> <p>The fault reaction time corresponds to the reaction time, except on SPM modules with an encoder/proximity switch interface. In this case, the fault reaction time is 2 s.</p>	Base unit	12.75–14.75	+ T _{Input_filter}
	MSC-CB-S + 1 extension module	13.83–37.84	+ T _{Input_filter}
	MSC-CB-S + 2 extension modules	14.91–40.00	+ T _{Input_filter}
	MSC-CB-S + 3 extension modules	15.99–42.16	+ T _{Input_filter}
	MSC-CB-S + 4 extension modules	17.07–44.32	+ T _{Input_filter}
	MSC-CB-S + 5 extension modules	18.15–46.48	+ T _{Input_filter}
	MSC-CB-S + 6 extension modules	19.23–48.64	+ T _{Input_filter}
	MSC-CB-S + 7 extension modules	20.31–50.80	+ T _{Input_filter}
	MSC-CB-S + 8 extension modules	21.39–52.96	+ T _{Input_filter}
	MSC-CB-S + 9 extension modules	22.47–55.12	+ T _{Input_filter}
	MSC-CB-S + 10 extension modules	23.55–57.28	+ T _{Input_filter}
	MSC-CB-S + 11 extension modules	24.63–59.44	+ T _{Input_filter}
	MSC-CB-S + 12 extension modules	25.71–61.60	+ T _{Input_filter}
	MSC-CB-S + 13 extension modules	26.79–63.76	+ T _{Input_filter}
MSC-CB-S + 14 extension modules	27.87–65.92	+ T _{Input_filter}	
MSC-CB/MS-CB-S > module connection	Proprietary 5-way bus (MSCB) from EUCHNER		
Connecting cable cross-section	0.5–2.5 mm ² /AWG 12–30 (single conductor/multiple conductor)		
Connection length, max.	100 m		
Operating temperature	-10–55 °C		
Ambient temperature, max.	55 °C (UL)		
Storage temperature	-20–85 °C		
Relative humidity	10%–95%		
Max. altitude (above sea level)	2,000 m		

➔ T_{Input_filter} = max. filter time related to the settings on the project inputs (see section “INPUTS”).

8.1.3. Housing

Description	Electronics housing, 24-pin, max.
Material of housing	Polyamide
Degree of protection, housing	IP20
Degree of protection, terminal blocks	IP 2X
Mounting	Quick-release connection to rail as per EN 60715
Dimensions (H x W x D) in mm	108 x 22.5 x 114.5

8.1.4. Module MSC-CB

PFH _D (EN IEC 61508:2010)	6.86 E-9
Operating voltage	24 VDC ±20%
Power dissipation	3 W max.
Module enable (no./description)	2/ PNP Active High “type B” as per EN 61131-2
Digital INPUTS (no./description)	8/ PNP Active High as per EN 61131-2
INPUT_FBK/RESTART (no./description)	2/ EDM control system/automatic or manual operation possible using RESTART button
Test OUTPUT (no./description)	4/ for checking for short circuits, overload states
Digital OUTPUTS (no./description)	2/ programmable – PNP Active High
OSSD (no./description)	2 pairs/static safety outputs – PNP Active High 400 mA at 24 VDC max.
Slot for the M-A1	Available
Connection to PC	USB 2.0 (Hi Speed) – cable length max.: 3 m
Connection to extension module	Via proprietary 5-way MSCB from EUCHNER

8.1.5. Module MSC-CB-S

PFH _D (EN IEC 61508:2010)	1.35 E-8
Operating voltage	24 VDC ±20%
Power dissipation	3 W max.
Digital INPUTS (no./description)	8/ PNP Active High as per EN 61131-2
INPUT_FBK/RESTART (no./description)	≤ 4/EDM control system/automatic or manual mode possible using RESTART pushbutton
Test OUTPUT (no./description)	4/ for checking for short circuits, overload states
Digital OUTPUTS (no./description)	≤ 4/ programmable – PNP Active High
OSSD (no./description)	4 single/static safety outputs – PNP Active High 400 mA at 24 VDC max.
Slot for the M-A1	Available
Connection to PC	USB 2.0 (Hi Speed) – cable length max.: 3 m
Connection to extension module	Via proprietary 5-way MSCB from EUCHNER

8.1.6. Module FI8FO2

PFH _D (EN IEC 61508:2010)	5.72 E-9
Operating voltage	24 VDC ±20%
Power dissipation	3 W max.
Digital INPUTS (no./description)	8/ PNP Active High as per EN 61131-2
Test OUTPUT (no./description)	8/ for checking for short circuits, overload states
Digital OUTPUTS (no./description)	2/ programmable – PNP Active High
OSSD (no./description)	2 pairs/static safety outputs – PNP Active High 400 mA at 24 VDC max.
Connection to MSC-CB and MSC-CB-S	Via proprietary 5-way MSCB from EUCHNER

8.1.7. Module FI8FO4S

PFH _D (EN IEC 61508:2010)	1.32 E-8
Operating voltage	24 VDC ±20%
Power dissipation	3 W max.
Digital INPUTS (no./description)	8/ PNP Active High as per EN 61131-2
Test OUTPUT (no./description)	4/ for checking for short circuits, overload states
Digital OUTPUTS (no./description)	≤ 4/ programmable – PNP Active High
OSSD (no./description)	4 single/static safety outputs – PNP Active High 400 mA at 24 VDC max.
Connection to MSC-CB-S	Via proprietary 5-way MSCB from EUCHNER

8.1.8. Modules FI8 – FI16

Module	FI8	FI16
PFH _D (EN IEC 61508:2010)	4.45 E-9	4.94 E-9
Operating voltage	24 VDC ±20%	
Power dissipation	3 W max.	
Digital INPUTS (no./description)	8	16
	PNP Active High as per EN 61131-2	
Test OUTPUT (no./description)	4/ for checking for short circuits, overload states	
Connection to MSC-CB	Via proprietary 5-way bus MSC from EUCHNER	

8.1.9. Module FM4

PFH _D (EN IEC 61508:2010)	5.56 E-9
Operating voltage	24 VDC ±20%
Power dissipation	3 W max.
Digital INPUTS (no./description)	12/ PNP Active High as per EN 61131-2
Test OUTPUT (no./description)	8/ for checking for short circuits, overload states
Connection to MSC-CB	Via proprietary 5-way bus MSCB from EUCHNER

8.1.10. Modules AC-F02 – AC-F04

Module	AC-F02	AC-F04
PFH _D (EN IEC 61508:2010)	4.09 E-9	5.84 E-9
Operating voltage	24 VDC ±20%	
Power dissipation	3 W max.	
Digital OUTPUTS (no./description)	2	4
	Programmable – PNP Active High	
OSSD (no./description)	2	4
	Safe switching outputs: PNP Active High – 400 mA at 24 VDC max.	
Connection to MSC-CB	Via proprietary 5-way bus MSCB from EUCHNER	

8.1.11. Module AH-F04S08

PFH _D (IEC 61508:2010)	9.28 E-09
Operating voltage	24 VDC ± 20%
Power dissipation	4 W max.
Current, OSSD outputs	Max. 2 A per channel
Number of safety outputs (OSSD)	2 pairs (or 4 single)/static safety outputs – PNP Active High, 400 mA at 24 VDC max., cat. 4
INPUT_FBK/RESTART (no./description)	4/ EDM control system/automatic or manual operation possible using RESTART button
Digital OUTPUTS (no./description)	8/ programmable outputs – PNP Active High
PNP Active High	
Response time	12 ms
Connection to MSC-CB	Via proprietary 5-way bus MSCB from EUCHNER

➔ * On the use of the module AH-F04S08 with output current > 500 mA, the module must be separated from the neighboring modules by fitting an MSC plug connector in between.

8.1.12. Modules SPMO – SPM1 – SPM2

Module	SPMO	SPM1	SPM2
PFH _D	7,48E-09	–	–
PFH _D (TTL/B)	–	9,32E-09 (SPM1TB)	1,12E-08 (SPM2TB)
PFH _D (sin/cos)	–	9,43E-09 (SPM1S)	1,14E-08 (SPM2S)
PFH _D (HTL24))	–	8,20E-09 (SPM1H)	8,92E-09 (SPM2H)
Operating voltage	24 VDC ±20%		
Power dissipation	3 W max.		
Encoder interface	–	TTL (models SPM1TB/SPM2TB) HTL (models SPM1H/SPM2H) sin/cos (models SPM1S/SPM2S)	
Encoder connections	–	RJ45	
Encoder input signals electrically isolated as per EN 61800 5	Rated insulation voltage 250 V Overvoltage category II Rated impulse withstand voltage 4.00 kV		
Number of encoders, max.	–	1	2
Encoder frequency, max.	–	500 kHz (HTL: 300 kHz)	
Configurable encoder limit range	–	1 Hz – 450 kHz	
Proximity switch type	PNP/NPN – 3/4-wire		
Proximity switch connections	Plug-in terminals		
Configurable proximity switch limit ranges	1 Hz – 4 kHz		
Number of proximity switches, max.	2		
Max. frequency, proximity switch	5 kHz		
Max. number of axes	2		
Frequency spacing, standstill/overspeed	> 10 Hz		
Threshold spacing	> 5%		
Connection to MSC-CB	Via proprietary 5-way bus MSCB from EUCHNER		

8.1.13. Modules AZ-F04 – AZ-F0408

Module	AZ-F04	AZ-F0408
PFH _D (EC IEC 61508:2010)	2.9 E-9	2.94 E-9
Operating voltage	24 VDC ±20%	
Power dissipation	3 W max.	
Switching voltage	240 VAC	
Switching current	6 A max.	
Normally open contacts	4	
INPUT FBK/RESTART (no./description)	4/ EDM control system/automatic or manual operation possible using RESTART button	
Digital OUTPUT (no./description)	–	8/ programmable output PNP Active High
Response time	12 ms	
Mechanical life of contacts	> 40 x 10 ⁶	
Connection	Terminal blocks	
Connection to MSC-CB	Via proprietary 5-way bus MSCB from EUCHNER	

8.1.14. Modules O8 – O16

Module	O8	O16
Operating voltage	24 VDC ±20%	
Power dissipation	3 W max.	
SIGNAL OUTPUTS (no./description)	8	16
	Programmable output – PNP Active High	
Connection to MSC-CB	Via proprietary 5-way bus MSCB from EUCHNER	

8.2. Mechanical dimensions

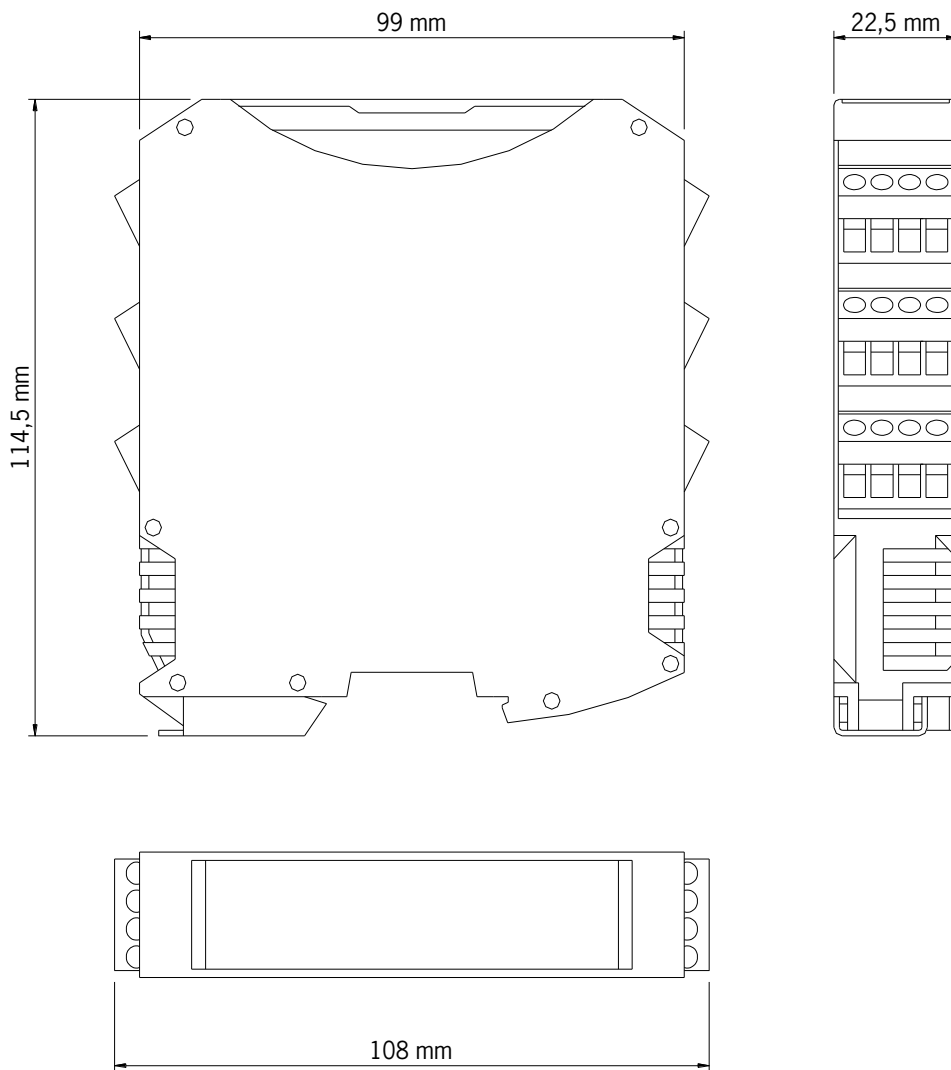

Figure 12: Module dimensions

8.3. Signals

8.3.1. Base unit MSC-CB (Figure 13)

MEANING	LED								
	RUN GREEN	IN FAIL RED	EXT FAIL RED	COM ORANGE	ENA BLUE	INI-8 YELLOW	OSSD1/2 RED/GREEN	CLEAR1/2 YELLOW	STATUS1/2 YELLOW
Switch on – initial CHECK	ON	ON	ON	ON	ON	ON	Red	ON	ON
MA-1 detected	OFF	OFF	OFF	ON (max. 1 s)	ON (max. 1 s)	OFF	Red	OFF	OFF
Writing/loading the diagram to/from MA-1	OFF	OFF	OFF	Flashes 5 times	Flashes 5 times	OFF	Red	OFF	OFF
SWSD is requesting connection: no internal configuration	OFF	OFF	OFF	Flashing slowly	OFF	OFF	Red	OFF	OFF
SWSD is requesting connection: (extension module or node number not correct) (see System layout)	OFF	OFF	OFF	Flashing quickly	OFF	OFF	Red	OFF	OFF
SWSD is requesting connection: (extension module missing or not ready) (see System layout)	Flashing quickly	OFF	OFF	Flashing quickly	OFF	OFF	Red	OFF	OFF
SWSD connected, MSC-CB stopped	OFF	OFF	OFF	ON	OFF	OFF	Red	OFF	OFF

Table 22: Indication on starting

MEANING	LED								
	RUN GREEN	IN FAIL RED	EXT FAIL RED	COM ORANGE	INI-8 YELLOW	ENA BLUE	OSSD1/2 RED/GREEN	CLEAR1/2 YELLOW	STATUS1/2 YELLOW
NORMAL OPERATION	ON	OFF	OFF Operation OK	ON = MSC-CB connected to PC OFF = Others	INPUT state	ON MASTER_ENABLE1 and MASTER_ENABLE2 Active OFF others	RED If output OFF GREEN If output ON	ON Waiting for RESTART Flashing NO feedback loop	OUTPUT state
EXTERNAL ERROR DETECTED	ON	OFF	ON Erroneous external connection detected	ON = MSC-CB connected to PC OFF = Others	Only the number of the INPUT with the erroneous connection flashes				

Table 23: Dynamic indication

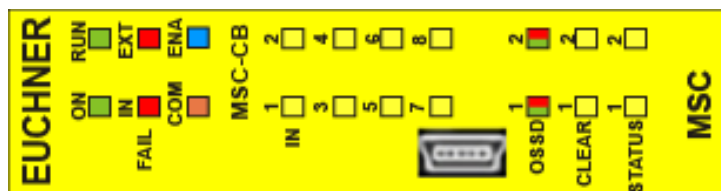

Figure 13:
MSC-CB

8.3.2. Base unit MSC-CB-S (Figure 14)

MEANING	LED							
	RUN GREEN	IN FAIL RED	EXT FAIL RED	COM ORANGE	ENA BLUE	INI-8 YELLOW	OSSD1/4 RED/GREEN/YELLOW	STATUS1/4 YELLOW
Switch on – initial CHECK	ON	ON	ON	ON	ON	ON	Red	ON
M-A1 detected	OFF	OFF	OFF	ON (max. 1 s)	ON (max. 1 s)	OFF	Red	OFF
Writing/loading the diagram to/from M-A1	OFF	OFF	OFF	Flashes 5 times	Flashes 5 times	OFF	Red	OFF
SWSD is requesting connection: no internal configuration	OFF	OFF	OFF	Flashing slowly	OFF	OFF	Red	OFF
SWSD is requesting connection: (extension module or node number not correct) (see System layout)	OFF	OFF	OFF	Flashing quickly	OFF	OFF	Red	OFF
SWSD is requesting connection: (extension module missing or not ready) (see System layout)	Flashing quickly	OFF	OFF	Flashing quickly	OFF	OFF	Red	OFF
SWSD connected, MSC-CB stopped	OFF	OFF	OFF	ON	OFF	OFF	Red	OFF

Table 24: Indication on starting

MEANING	LED							
	RUN GREEN	IN FAIL RED	EXT FAIL RED	COM ORANGE	INI-8 YELLOW	ENA BLUE	OSSD1/4 RED/GREEN/YELLOW	STATUS1/4 YELLOW
NORMAL OPERATION	ON	OFF	OFF Operation OK	ON = MSC-CB-S connected to PC OFF = Others	INPUT state		RED if output OFF GREEN if output ON	OUTPUT state
EXTERNAL ERROR DETECTED	ON	OFF	ON Erroneous external connection detected	ON = MSC-CB-S connected to PC OFF = Others	Only the number of the INPUT with the erroneous connection flashes	ON	YELLOW Waiting for RESTART YELLOW FLASHING NO feedback loop	

Table 25: Dynamic indication

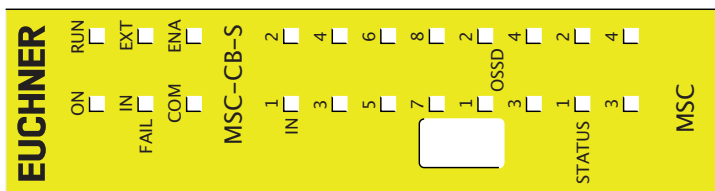

Figure 14:
MSC-CB-S

8.3.3. Module FI8FO2 (Figure 15)

MEANING	LED							
	RUN GREEN	IN FAIL RED	EXT FAIL RED	SEL ORANGE	INI-8 YELLOW	OSSD1/2 RED/GREEN	CLEAR1/2 YELLOW	STATUS1/2 YELLOW
Switch on – initial CHECK	ON	ON	ON	ON	ON	Red	ON	ON

Table 26: Indication on starting

MEANING	LED							
	RUN GREEN	IN FAIL RED	EXT FAIL RED	INI-8 YELLOW	SEL ORANGE	OSSD1/2 RED/GREEN	CLEAR1/2 YELLOW	STATUS1/2 YELLOW
NORMAL OPERATION	OFF	OFF	OFF	INPUT state	Indicates the signal table NODE_SEL0/1	RED if output OFF GREEN if output ON	ON Waiting for RESTART FLASHING NO feedback loop	OUTPUT state
	FLASHING If no INPUT or OUTPUT is requested by the configuration ON If INPUT or OUTPUT is requested by the configuration	ON Erroneous external connection detected	Only the number of the INPUT with the erroneous connection flashes					

Table 27: Dynamic indication

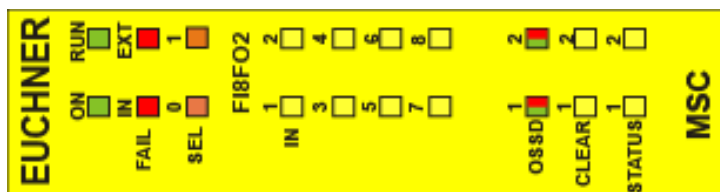

Figure 15:
FI8FO2

8.3.4. Module FI8FO4S (Figure 16)

MEANING	LED							
	RUN GREEN	IN FAIL RED	EXT FAIL RED	SELO/1 ORANGE	INI-8 YELLOW	OSSDI/4 RED/GREEN/YELLOW	STATUS1/4 YELLOW	
Switch on – initial CHECK	ON	ON	ON	ON	ON	Red	ON	

Table 28: Indication on starting

MEANING	LED							
	RUN GREEN	IN FAIL RED	EXT FAIL RED	INI-8 YELLOW	SELO/1 ORANGE	OSSDI/4 RED/GREEN/YELLOW	STATUS1/2 YELLOW	
NORMAL OPERATION	OFF	OFF	OFF	INPUT state		RED If output OFF		
	FLASHING	ON	ON	Only the number of the INPUT with the erroneous connection flashes	Indicates the signal table NODE_SELO/1	GREEN If output ON	OUTPUT state	
	ON	ON	ON	Erroneous external connection detected		YELLOW Waiting for RESTART	YELLOW FLASHING NO feedback loop	

Table 29: Dynamic indication

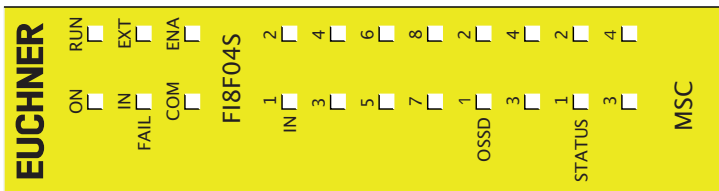

Figure 16:
FI8FO4S

8.3.5. Module FI8 (Figure 17)

MEANING	LED				
	RUN GREEN	IN FAIL RED	EXT FAIL RED	SEL ORANGE	IN1-8 YELLOW
Switch on – initial CHECK	ON	ON	ON	ON	ON

Table 30: Indication on starting

MEANING	LED				
	RUN GREEN	IN FAIL RED	EXT FAIL RED	SEL ORANGE	IN1-8 YELLOW
NORMAL OPERATION	OFF If the module is waiting for the first message from the base unit	OFF	OFF	Indicates the signal table NODE_SEL0/1	INPUT state
	FLASHING If no INPUT or OUTPUT is requested by the configuration				
	ON If INPUT or OUTPUT is requested by the configuration		ON Erroneous external connection detected		Only the number of the INPUT with the erroneous connection flashes

Table 31: Dynamic indication

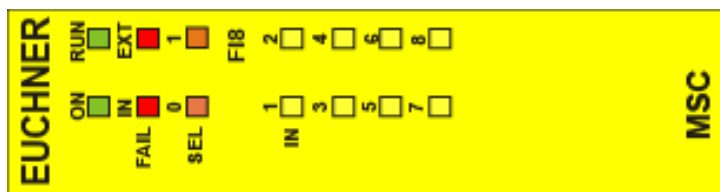

Figure 17:
FI8

8.3.6. Module FM4 (Figure 18)

MEANING	LED				
	RUN GREEN	IN FAIL RED	EXT FAIL RED	SEL ORANGE	INI-12 YELLOW
Switch on – initial CHECK	ON	ON	ON	ON	ON

Table 32: Indication on starting

MEANING	LED				
	RUN GREEN	IN FAIL RED	EXT FAIL RED	SEL ORANGE	INI-12 YELLOW
NORMAL OPERATION	OFF If the module is waiting for the first message from the base unit FLASHING If no INPUT or OUTPUT is requested by the configuration ON If INPUT or OUTPUT is requested by the configuration	OFF	OFF	Indicates the signal table NODE_SEL0/1	INPUT state
			ON	Erroneous external connection detected	Only the number of the INPUT with the erroneous connection flashes

Table 33: Dynamic indication

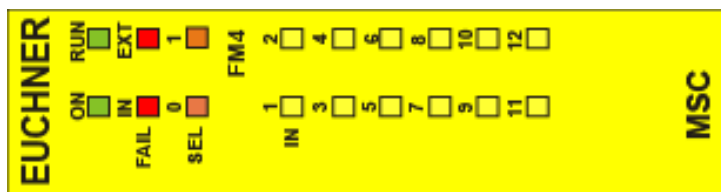

Figure 18:
FM4

8.3.7. Module FI16 (Figure 19)

MEANING	LED					
	RUN GREEN	IN FAIL RED	EXT FAIL RED	SEL ORANGE	INI-16 YELLOW	
Switch on – initial CHECK	ON	ON	ON	ON	ON	ON

Table 34: Indication on starting

MEANING	LED					
	RUN GREEN	IN FAIL RED	EXT FAIL RED	SEL ORANGE	INI-16 YELLOW	
NORMAL OPERATION	OFF	OFF	OFF	Indicates the signal table NODE_SEL0/1	INPUT state	
	FLASHING If no INPUT or OUTPUT is requested by the configuration ON If INPUT or OUTPUT is requested by the configuration	OFF	ON Erroneous external connection detected			Only the number of the INPUT with the erroneous connection flashes

Table 35: Dynamic indication

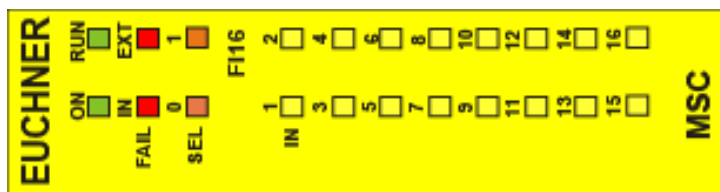

Figure 19:
FI16

8.3.8. Module AC-F02 (Figure 20)

MEANING	LED						
	RUN GREEN	IN FAIL RED	EXT FAIL RED	SEL ORANGE	OSSD1/2 RED/GREEN	CLEAR1/2 YELLOW	STATUS1/2 YELLOW
Switch on – initial CHECK	ON	ON	ON	ON	Red	ON	ON

Table 36: Indication on starting

MEANING	LED						
	RUN GREEN	IN FAIL RED	EXT FAIL RED	SEL ORANGE	OSSD1/2 RED/GREEN	CLEAR1/2 YELLOW	STATUS1/2 YELLOW
NORMAL OPERATION	OFF If the module is waiting for the first message from the base unit	OFF Operation OK	OFF Operation OK	Indicates the signal table NODE_SEL0/1	RED If output OFF	ON Waiting for RE-START	OUTPUT state
	FLASHING If no INPUT or OUTPUT is requested by the configuration	OFF Operation OK	OFF Operation OK		GREEN If output ON	Flashing NO feedback loop	
	ON If INPUT or OUTPUT is requested by the configuration						

Table 37: Dynamic indication



Figure 20:
AC-F02

8.3.9. Module AC-F04 (Figure 21)

MEANING	LED							
	RUN GREEN	IN FAIL RED	EXT FAIL RED	SEL ORANGE	OSSD1/4 RED/GREEN	CLEAR1/4 YELLOW	STATUS1/4 YELLOW	
Switch on – initial CHECK	ON	ON	ON	ON	Red	ON	ON	

Table 38: Indication on starting

MEANING	LED							
	RUN GREEN	IN FAIL RED	EXT FAIL RED	SEL ORANGE	OSSD1/4 RED/GREEN	CLEAR1/4 YELLOW	STATUS1/4 YELLOW	
NORMAL OPERATION	OFF If the module is waiting for the first message from the base unit	OFF Operation OK	OFF Operation OK	Indicates the signal table NODE_SEL0/1	RED If output OFF	ON Waiting for RE-START	OUTPUT state	
	FLASHING If no INPUT or OUTPUT is requested by the configuration	OFF Operation OK	OFF Operation OK		GREEN If output ON	Flashing NO feedback loop		
	ON If INPUT or OUTPUT is requested by the configuration							

Table 39: Dynamic indication

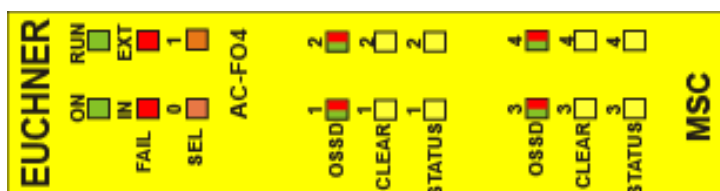

Figure 21:
AC-F04

8.3.10. Module AZ-FO4 (Figure 22)

MEANING	LED								
	RUN GREEN	IN FAIL RED	EXT FAIL RED	SELO/1 ORANGE	RELAY1/4 RED/GREEN	CLEAR1/4 YELLOW	SELO/1 ORANGE	RELAY1/4 RED/GREEN	CLEAR1/4 YELLOW
Switch on – initial CHECK	ON	ON	ON	ON	Red	ON	ON	Red	ON

Table 40: Indication on starting

MEANING	LED								
	RUN GREEN	IN FAIL RED	EXT FAIL RED	SELO/1 ORANGE	RELAY1/4 RED/GREEN	CLEAR1/4 YELLOW	SELO/1 ORANGE	RELAY1/4 RED/GREEN	CLEAR1/4 YELLOW
NORMAL OPERATION	OFF	OFF	OFF	Indicates the signal table NODE_SELO/1	RED With open contact	ON Waiting for RESTART	Indicates the signal table NODE_SELO/1	RED With open contact	ON Waiting for RESTART
	FLASHING	OFF	OFF	Indicates the signal table NODE_SELO/1	GREEN With closed contact	FLASHING Error feedback loop external switchgear	Indicates the signal table NODE_SELO/1	GREEN With closed contact	FLASHING Error feedback loop external switchgear
	ON	OFF	OFF	Indicates the signal table NODE_SELO/1	GREEN With closed contact	ON Error feedback loop external switchgear	Indicates the signal table NODE_SELO/1	GREEN With closed contact	ON Error feedback loop external switchgear

Table 41: Dynamic indication

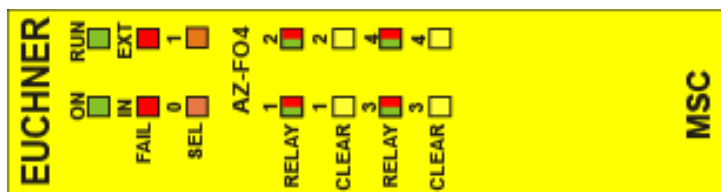

Figure 22:
AZ-FO4

8.3.11. Module AZ-F04F08 (Figure 23)

MEANING	LED							
	RUN GREEN	IN FAIL RED	EXT FAIL RED	SELO/1 ORANGE	RELAY1/4 RED/GREEN	CLEAR1/4 YELLOW	STATUS1/8 YELLOW	
Switch on – initial CHECK	ON	ON	ON	ON	Red	ON	ON	

Table 42: Indication on starting

MEANING	LED							
	RUN GREEN	IN FAIL RED	EXT FAIL RED	SELO/1 ORANGE	RELAY1/4 RED/GREEN	CLEAR1/4 YELLOW	STATUS1/8 YELLOW	
NORMAL OPERATION	OFF If the module is waiting for the first message from the base unit	OFF Operation OK	OFF Operation OK	Indicates the signal table NODE_SELO/1	RED With open contact	ON Waiting for RE-START	OUTPUT state	
	FLASHING If no INPUT or OUTPUT is requested by the configuration	OFF Operation OK	OFF Operation OK		GREEN With closed contact	FLASHING Error feedback loop external switch/gear		
	ON If INPUT or OUTPUT is requested by the configuration							

Table 43: Dynamic indication

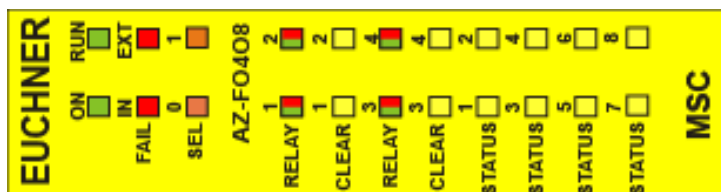

Figure 23:
AZ-F0408

8.3.12. Module O8 (Figure 24)

MEANING	LED			
	RUN GREEN	IN FAIL RED	EXT FAIL RED	SELO/1 ORANGE
Switch on – initial CHECK	ON	ON	ON	ON

Table 44: Indication on starting

MEANING	LED			
	RUN GREEN	IN FAIL RED	EXT FAIL RED	SELO/1 ORANGE
NORMAL OPERATION	OFF			
	FLASHING	OFF	OFF	Indicates the signal table NODE_SELO/1
	ON	OFF	OFF	State OUTPUT

Table 45: Dynamic indication

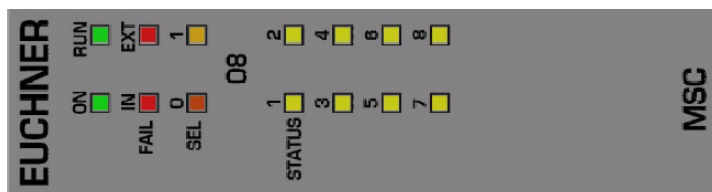

Figure 24:
O8

8.3.13. Module O16 (Figure 25)

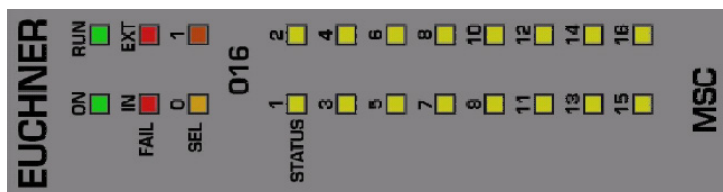

Figure 25:
O16

MEANING	LED			
	RUN GREEN	IN FAIL RED	EXT FAIL RED	STATUS1/16 YELLOW
Switch on – initial CHECK	ON	ON	ON	ON

Table 46: Indication on starting

MEANING	LED			
	RUN GREEN	IN FAIL RED	EXT FAIL RED	STATUS1/16 YELLOW
NORMAL OPERATION	OFF If the module is waiting for the first message from the base unit	OFF Operation OK	OFF Operation OK	State OUTPUT
	FLASHING If no INPUT or OUTPUT is requested by the configuration	OFF Operation OK	OFF Operation OK	Indicates the signal table NODE_SELO/1
	ON If INPUT or OUTPUT is requested by the configuration	OFF Operation OK	OFF Operation OK	Indicates the signal table NODE_SELO/1

Table 47: Dynamic indication

8.3.14. Modules SPM0 – SPM1 – SPM2 (Figure 26)

MEANING	LED						
	RUN GREEN	IN FAIL RED	EXT FAIL RED	SEL ORANGE	ENC* YELLOW	PROX YELLOW	SH YELLOW
Switch on – initial CHECK	ON	ON	ON	ON	Red	ON	ON

Table 48: Indication on starting

MEANING	LED						
	RUN GREEN	IN FAIL RED	EXT FAIL RED	SEL ORANGE	ENC* YELLOW	PROX YELLOW	SH YELLOW
NORMAL OPERATION	OFF				ON	ON	OFF
	If the module is waiting for the first message from the base unit				Encoder connected and operational	Proximity switch connected and operational	Axis in normal speed range
	FLASHING If no INPUT or OUTPUT is requested by the configuration				FLASHING Encoder not connected but requested by the configuration	FLASHING 0.5 s Proximity switch not connected but requested by the configuration	FLASHING Axis at elevated speed
	ON					FLASHING 2 s Fault on proximity switch	ON
	If INPUT or OUTPUT is requested by the configuration						Axis at standstill

Table 49: Dynamic indication

* IF SPM0 MODULE NOT FITTED

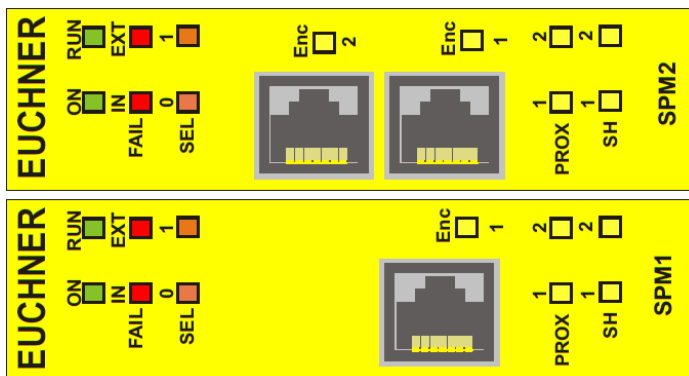

Figure 26:
Speed monitoring modules
SPM1, SPM2

8.3.15. Module AH-F04S08 (Figure 27)

MEANING	LED							
	RUN GREEN	IN FAIL RED	EXT FAIL RED	SELO/1 ORANGE	RELAY1/4 RED/GREEN	CLEAR1/4 YELLOW	STATUS1/8 YELLOW	
Switch on – initial CHECK	ON	ON	ON	ON	Red	ON	ON	

Table 50: Indication on starting

MEANING	LED							
	RUN GREEN	IN FAIL RED	EXT FAIL RED	SELO/1 ORANGE	RELAY1/4 RED/GREEN	CLEAR1/4 YELLOW	STATUS1/8 YELLOW	
NORMAL OPERATION	OFF If the module is waiting for the first message from the base unit	OFF Operation OK	OFF Operation OK	Indicates the signal table NODE_SELO/1	RED If output is OFF	ON Waiting for RE-START	ON Assigned SYSTEM STATUS output is active	
	FLASHING If no INPUT or OUTPUT is requested by the configuration	OFF Operation OK	OFF Operation OK		GREEN If output ON	FLASHING Erroneous external feedback contactors	OFF Assigned SYSTEM STATUS output is inactive	
	ON If INPUT or OUTPUT is requested by the configuration							

Table 51: Dynamic indication

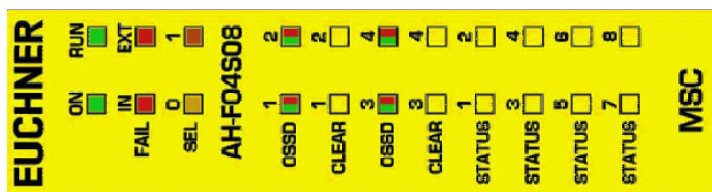

Figure 27:
AH-F04S08

8.4. Fault diagnostics

8.4.1. Base unit MSC-CB (Figure 28)

MEANING	LED										RECTIFICATION MEASURE
	RUN GREEN	IN FAIL RED	EXT FAIL RED	COM ORANGE	IN1-8 YELLOW	ENA BLUE	OSSD1/2 RED/GREEN	CLEAR1/2 YELLOW	STATUS1/2 YELLOW		
Internal error	OFF	Flashes 2 or 3 times	OFF	OFF	OFF	OFF	Red	OFF	OFF	OFF	<ul style="list-style-type: none"> ▶ Send module to EUCHNER for repair
OSSD output error	OFF	Flashes 4 times	OFF	OFF	OFF	OFF	Flashes 4 times (only the LED for the output in the error mode)	OFF	OFF	OFF	<ul style="list-style-type: none"> ▶ Check OSSD1/2 connections ▶ If the problem persists, send MSC-CB to EUCHNER for repair.
Error during communication with extension module	OFF	Flashes 5 times	OFF	OFF	OFF	OFF	OFF	OFF	OFF	OFF	<ul style="list-style-type: none"> ▶ Restart system. ▶ If the problem persists, send MSC-CB to EUCHNER for repair.
Error in extension module	OFF	ON	OFF	OFF	OFF	OFF	OFF	OFF	OFF	OFF	<ul style="list-style-type: none"> ▶ Restart system. ▶ Check which module is in the ERROR mode.
Error M-A1	OFF	Flashes 6 times	OFF	Flashes 6 times	OFF	OFF	OFF	OFF	OFF	OFF	<ul style="list-style-type: none"> ▶ Replace M-A1

Table 52: Troubleshooting MSC-CB

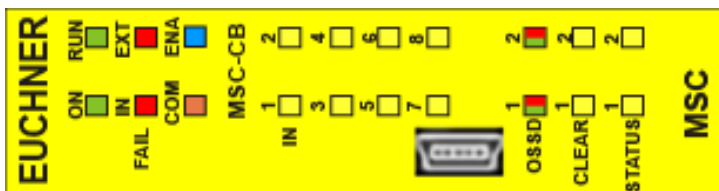

Figure 28:
MSC-CB

8.4.2. Base unit MSC-CB-S (Figure 29)

MEANING	LED								RECTIFICATION MEASURE
	RUN GREEN	IN FAIL RED	EXT FAIL RED	COM ORANGE	IN1-8 YELLOW	ENA BLUE	OSSD1/4 RED/GREEN/YELLOW	STATUS1/4 YELLOW	
Internal error	OFF	Flashes 2 or 3 times	OFF	OFF	OFF	OFF	Red	OFF	<ul style="list-style-type: none"> Send module to EUCHNER for repair
OSSD output error	OFF	Flashes 4 times	OFF	OFF	OFF	OFF	Flashes 4 times (only the LED for the output in the error mode)	OFF	<ul style="list-style-type: none"> Check OSSD1/2 connections If the problem persists, send MSC-CB-S to EUCHNER for repair.
Error during communication with extension module	OFF	Flashes 5 times	OFF	OFF	OFF	OFF	OFF	OFF	<ul style="list-style-type: none"> Restart system. If the problem persists, send MSC-CB-S to EUCHNER for repair.
Error in extension module	OFF	ON	OFF	OFF	OFF	OFF	OFF	OFF	<ul style="list-style-type: none"> Restart system. Check which module is in the ERROR mode.
Error MA1	OFF	Flashes 6 times	OFF	Flashes 6 times	OFF	OFF	OFF	OFF	<ul style="list-style-type: none"> Replace MA1
OSSD overload or load connected to 24 VDC	ON	OFF	ON	OFF	INPUT state	ON	RED flashing (only the LED corresponding to the output in the error mode)	OUTPUT state	<ul style="list-style-type: none"> Check OSSD output connections
Short circuit or overload on the status outputs	ON	OFF	ON	OFF	INPUT state	ON	OUTPUT state	Flashing	<ul style="list-style-type: none"> Check status output connections

Table 53: Troubleshooting MSC-CB-S

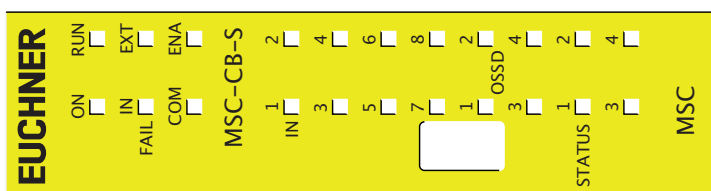

Figure 29:
MSC-CB-S

8.4.3. Module FI8FO2 (Figure 30)

MEANING	LED								RECTIFICATION MEASURE
	RUN GREEN	IN FAIL RED	EXT FAIL RED	SEL ORANGE	INI-8 YELLOW	OSSD1/2 RED/GREEN	CLEAR1/2 YELLOW	STATUS1/2 YELLOW	
Internal error	OFF	Flashes 2 or 3 times	OFF		OFF	Red	OFF	OFF	<ul style="list-style-type: none"> Send module to EUCHNER for repair
Compatibility error	OFF	Flashes 5 times	OFF		Flashes 5 times	Flashes 5 times	Flashes 5 times	Flashes 5 times	<ul style="list-style-type: none"> Firmware version not compatible with MSC-CB. Send to EUCHNER for firmware upgrade.
OSSD output error	OFF	Flashes 4 times	OFF		OFF	Flashes 4 times (only the LED for the output in the error mode)	OFF	OFF	<ul style="list-style-type: none"> Check OSSD1/2 connections If the problem persists, send FI8FO2 to EUCHNER for repair.
Error during communication with base unit	OFF	Flashes 5 times	OFF		OFF	OFF	OFF	OFF	<ul style="list-style-type: none"> Restart system. If the problem persists, send FI8FO2 to EUCHNER for repair.
Error in another extension module or MSC-CB	OFF	ON	OFF		OFF	OFF	OFF	OFF	<ul style="list-style-type: none"> Restart system. Check which module is in the ERROR mode.
Extension module of the same type with the same address detected	OFF	Flashes 5 times	Flashes 5 times		OFF	OFF	OFF	OFF	<ul style="list-style-type: none"> Change address of the module (see section NODE_SEL)
Internal node detection error	OFF	Flashes 3 times	OFF	RECTIFICATION MEASURE	OFF	OFF	OFF	OFF	<ul style="list-style-type: none"> Send to EUCHNER for repair.

Table 54: Troubleshooting FI8FO2

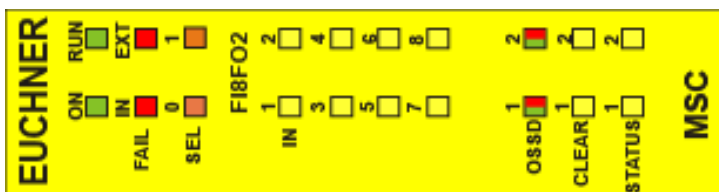

Figure 30:
FI8FO2

8.4.4. Module F18FO4S (Figure 31)

MEANING	LED								RECTIFICATION MEASURE
	RUN GREEN	IN FAIL RED	EXT FAIL RED	SEL ORANGE	IN1-8 YELLOW	OSSD1/4 RED/GREEN/YELLOW	STATUS1/4 YELLOW		
Internal error	OFF	Flashes 2 or 3 times	OFF	Indicates the physical address of the module	OFF	Red	OFF	<ul style="list-style-type: none"> Send module to EUCHNER for repair 	
Compatibility error	OFF	Flashes 5 times	OFF		Flashes 5 times	Flashes 5 times	Flashes 5 times	<ul style="list-style-type: none"> Firmware version not compatible with MSC-CB. Send to EUCHNER for firmware upgrade. 	
OSSD output error	OFF	Flashes 4 times	OFF		Flashes 4 times (only the LED for the output in the error mode)	Flashes 4 times	Flashes 4 times	<ul style="list-style-type: none"> Check OSSD1/2 connections If the problem persists, send F18FO4S to EUCHNER for repair. 	
Error during communication with base unit	OFF	Flashes 5 times	OFF		OFF	OFF	OFF	<ul style="list-style-type: none"> Restart system. If the problem persists, send F18FO4S to EUCHNER for repair. 	
Error in another extension module or MSC-CB	OFF	ON	OFF		OFF	OFF	OFF	<ul style="list-style-type: none"> Restart system. Check which module is in the ERROR mode. 	
Extension module of the same type with the same address detected	OFF	Flashes 5 times	Flashes 5 times		Flashes 5 times	OFF	OFF	<ul style="list-style-type: none"> Change address of the module (see section NODE_SEL) 	
OSSD overload or load connected to 24 VDC	ON	OFF	ON		INPUT state	RED flashing (only the LED corresponding to the output in the error mode)	OUTPUT state	<ul style="list-style-type: none"> Check OSSD output connections 	
Short circuit or overload on the status outputs	ON	OFF	ON		INPUT state	OUTPUT state	Flashing	<ul style="list-style-type: none"> Check status output connections 	

Table 55: Troubleshooting F18FO4S

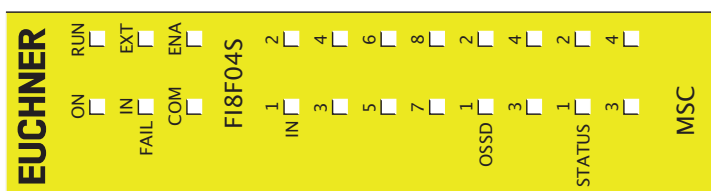

Figure 31:
F18FO4S

8.4.5. Module F18 (Figure 32)

MEANING	LED					RECTIFICATION MEASURE
	RUN GREEN	IN FAIL RED	EXT FAIL RED	SEL ORANGE	INI-8 YELLOW	
Internal error	OFF	Flashes 2 or 3 times	OFF		OFF	<ul style="list-style-type: none"> ▶ Send module to EUCHNER for repair.
Compatibility error	OFF	Flashes 5 times	OFF		Flashes 5 times	<ul style="list-style-type: none"> ▶ Firmware version not compatible with MSC-CB. Send to EUCHNER for firmware upgrade.
OSSD output error	OFF	Flashes 4 times	OFF		OFF	<ul style="list-style-type: none"> ▶ Restart system. ▶ If the problem persists, send F18 to EUCHNER for repair.
Error during communication with base unit	OFF	Flashes 5 times	OFF		OFF	<ul style="list-style-type: none"> ▶ Restart system. ▶ If the problem persists, send F18 to EUCHNER for repair.
Error in another extension module or MSC-CB	OFF	ON	OFF		OFF	<ul style="list-style-type: none"> ▶ Restart system. ▶ Check which module is in the ERROR mode.
Extension module of the same type with the same address detected	OFF	Flashes 5 times	Flashes 5 times		OFF	<ul style="list-style-type: none"> ▶ Change address of the module (see section NODE_SEL)
Internal node detection error	OFF	Flashes 3 times	OFF		Flashes 3 times	<ul style="list-style-type: none"> ▶ Send to EUCHNER for repair.

Table 56: Troubleshooting F18

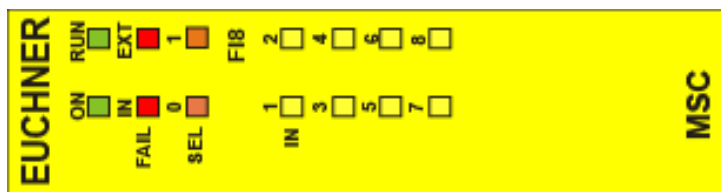

Figure 32:
F18

8.4.6. Module FM4 (Figure 33)

MEANING	LED					RECTIFICATION MEASURE
	RUN GREEN	IN FAIL RED	EXT FAIL RED	SEL ORANGE	INI-8 YELLOW	
Internal error	OFF	Flashes 2 or 3 times	OFF		OFF	<ul style="list-style-type: none"> ▶ Send module to EUCHNER for repair.
Compatibility error	OFF	Flashes 5 times	OFF		Flashes 5 times	<ul style="list-style-type: none"> ▶ Firmware version not compatible with MSC-CB. Send to EUCHNER for firmware upgrade.
OSSD output error	OFF	Flashes 4 times	OFF		OFF	<ul style="list-style-type: none"> ▶ Restart system. ▶ If the problem persists, send FM4 to EUCHNER for repair.
Error during communication with base unit	OFF	Flashes 5 times	OFF		OFF	<ul style="list-style-type: none"> ▶ Restart system. ▶ If the problem persists, send FM4 to EUCHNER for repair.
Error in another extension module or MSC-CB	OFF	ON	OFF		OFF	<ul style="list-style-type: none"> ▶ Restart system. ▶ Check which module is in the ERROR mode.
Extension module of the same type with the same address detected	OFF	Flashes 5 times	Flashes 5 times		OFF	<ul style="list-style-type: none"> ▶ Change address of the module (see section NODE_SEL)
Internal node detection error	OFF	Flashes 3 times	OFF		Flashes 3 times	<ul style="list-style-type: none"> ▶ Send to EUCHNER for repair.

Table 57: Troubleshooting FM4

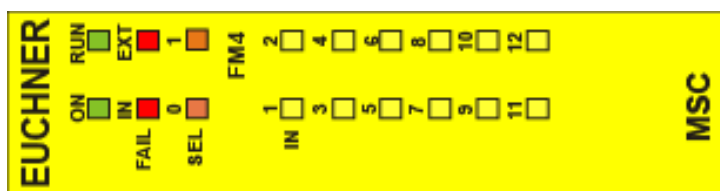

Figure 33:
FM4

8.4.7. Module FI16 (Figure 34)

MEANING	LED					RECTIFICATION MEASURE
	RUN GREEN	IN FAIL RED	EXT FAIL RED	SEL ORANGE	IN1-16 YELLOW	
Internal error	OFF	Flashes 2 or 3 times	OFF		OFF	<ul style="list-style-type: none"> Send module to EUCHNER for repair.
Compatibility error	OFF	Flashes 5 times	OFF		Flashes 5 times	<ul style="list-style-type: none"> Firmware version not compatible with MSC-CB. Send to EUCHNER for firmware upgrade.
Error during communication with base unit	OFF	Flashes 5 times	OFF		Indicates the physical address of the module	<ul style="list-style-type: none"> Restart system. If the problem persists, send FI16 to EUCHNER for repair.
Error in another extension module or MSC-CB	OFF	ON	OFF			<ul style="list-style-type: none"> Restart system. Check which module is in the ERROR mode.
Extension module of the same type with the same address detected	OFF	Flashes 5 times	Flashes 5 times			<ul style="list-style-type: none"> Change address of the module (see section NODE_SEL)
Internal node detection error	OFF	Flashes 3 times	OFF	Flashes 3 times	OFF	<ul style="list-style-type: none"> Send to EUCHNER for repair.

Table 58: Troubleshooting FI16

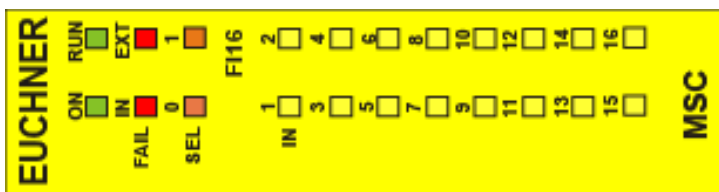

Figure 34:
FI16

8.4.8. Modules AC-F02/AC-F04 (Figure 35)

MEANING	LED						RECTIFICATION MEASURE	
	RUN GREEN	IN FAIL RED	EXT FAIL RED	SEL ORANGE	OSSD1/2 RED/GREEN	CLEAR1/2 YELLOW		STATUS1/4 YELLOW
Internal error	OFF	Flashes 2 or 3 times	OFF		Red	OFF	OFF	<ul style="list-style-type: none"> Send module to EUCHNER for repair.
Compatibility error	OFF	Flashes 5 times	OFF		Flashes 5 times	Flashes 5 times	Flashes 5 times	<ul style="list-style-type: none"> Firmware version not compatible with MSC-CB. Send to EUCHNER for firmware upgrade.
OSSD output error	OFF	Flashes 4 times	OFF		Flashes 4 times (only the LED for the output in the error mode)	OFF	OFF	<ul style="list-style-type: none"> Check OSSD1/2 connections. If the problem persists, send AC-F02/AC-F04 to EUCHNER for repair.
Error during communication with base unit	OFF	Flashes 5 times	OFF	Indicates the physical address of the module	OFF	OFF	OFF	<ul style="list-style-type: none"> Restart system. If the problem persists, send AC-F02/AC-F04 to EUCHNER for repair.
Error in another extension module or MSC-CB	OFF	ON	OFF		OFF	OFF	OFF	<ul style="list-style-type: none"> Restart system. Check which module is in the ERROR mode.
Extension module of the same type with the same address detected	OFF	Flashes 5 times	Flashes 5 times		OFF	OFF	OFF	<ul style="list-style-type: none"> Change address of the module (see section NODE_SEL)
Power supply failed on OSSD3/4 (only AC-F04)	ON	OFF	ON		Red flashing	Flashing	OUTPUT state	<ul style="list-style-type: none"> Connect terminals 13 and 14 to power supply
STATUS output overload or short circuit	OFF	OFF	ON		OSSD state	CLEAR state	Flashing	<ul style="list-style-type: none"> Check STATUS cable
Internal node detection error	OFF	Flashes 3 times	OFF	Flashes 3 times	OFF	OFF	OFF	<ul style="list-style-type: none"> Send to EUCHNER for repair.

Table 59: Troubleshooting AC-F02/AC-F04

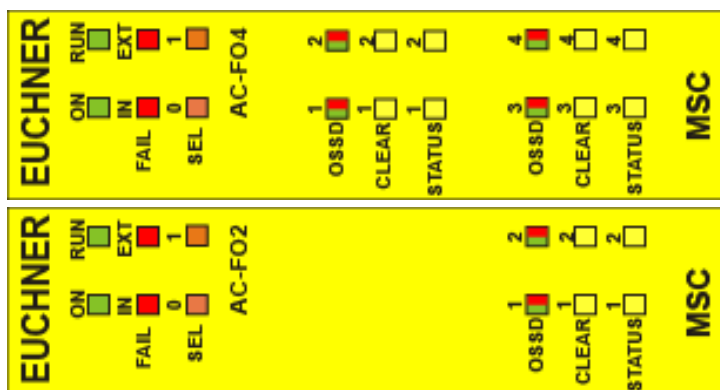

Figure 35:
AC-F02/AC-F04

8.4.9. Module AZ-F04 (Figure 36)

MEANING	LED						RECTIFICATION MEASURE
	RUN GREEN	IN FAIL RED	EXT FAIL RED	SELO/1 ORANGE	RELAY1/4 RED/GREEN	CLEAR1/4 YELLOW	
Internal error	OFF	Flashes 2 or 3 times	OFF		RED	OFF	<ul style="list-style-type: none"> ▶ Send module to EUCHNER for repair
Compatibility error	OFF	Flashes 5 times	OFF		Flashes 5 times	Flashes 5 times	<ul style="list-style-type: none"> ▶ Firmware version not compatible with MSC-CB. Send to EUCHNER for firmware upgrade.
Relay output error	OFF	Flashes 4 times	OFF		Flashes 4 times (only the LED corresponding to the output in the ERROR mode)	OFF	<ul style="list-style-type: none"> ▶ If the problem persists, send module to EUCHNER for repair.
Error during communication with base unit	OFF	Flashes 5 times	OFF	Indicates the physical address of the module	OFF	OFF	<ul style="list-style-type: none"> ▶ Restart system. ▶ If the problem persists, send module to EUCHNER for repair.
Error in another extension module or MSC-CB	OFF	ON	OFF		OFF	OFF	<ul style="list-style-type: none"> ▶ Restart system. ▶ Check which module is in the ERROR mode.
Extension module of the same type with the same address detected	OFF	Flashes 5 times	Flashes 5 times		OFF	OFF	<ul style="list-style-type: none"> ▶ Change address of the module (see section NODE_SEL)
External feedback loop error relay category 4	ON	OFF	Flashes 4 times		Flashes 4 times corresponding to the output in the ERROR mode)		<ul style="list-style-type: none"> ▶ Check terminals 5, 6, 7, 8
Internal node detection error	OFF	Flashes 3 times	OFF	Flashes 3 times	OFF	OFF	<ul style="list-style-type: none"> ▶ Send module to EUCHNER for repair

Table 60: Troubleshooting AZ-F04

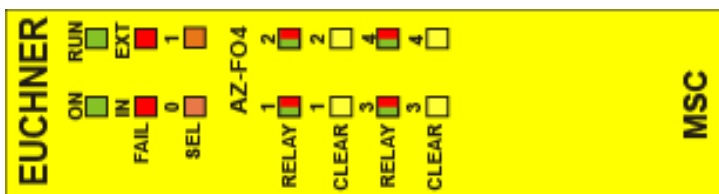

Figure 36:
AZ-F04

8.4.10. Module AZ-F0408 (Figure 37)

MEANING	LED								RECTIFICATION MEASURE
	RUN GREEN	IN FAIL RED	EXT FAIL RED	SELO/1 ORANGE	RELAY/4 RED/GREEN	CLEAR/4 YELLOW	STATUS/8 YELLOW		
Internal error	OFF	Flashes 2 or 3 times	OFF		RED	OFF	OFF	OFF	▶ Send module to EUCHNER for repair
Compatibility error	OFF	Flashes 5 times	OFF		Flashes 5 times	Flashes 5 times	Flashes 5 times	Flashes 5 times	▶ Firmware version not compatible with MSC-CB. Send to EUCHNER for firmware upgrade.
Relay output error	OFF	Flashes 4 times	OFF		Flashes 4 times (only the LED corresponding to the output in the ERROR mode)	OFF	OFF	OFF	▶ If the problem persists, send module to EUCHNER for repair.
Error during communication with base unit	OFF	Flashes 5 times	OFF	Indicates the physical address of the module	OFF	OFF	OFF	OFF	▶ Restart system. ▶ If the problem persists, send module to EUCHNER for repair.
Error in another extension module or MSC-CB	OFF	ON	OFF		OFF	OFF	OFF	OFF	▶ Restart system. ▶ Check which module is in the ERROR mode.
Extension module of the same type with the same address detected	OFF	Flashes 5 times	Flashes 5 times		OFF	OFF	OFF	OFF	▶ Change address of the module (see section NODE_SEL)
External feedback loop error relay category 4	ON	OFF	Flashes 4 times		Flashes 4 times (only the LED corresponding to the output in the ERROR mode)	OFF	OFF	OFF	▶ Check terminals 5, 6, 7, 8
Internal node detection error	OFF	Flashes 3 times	OFF	Flashes 3 times	OFF	OFF	OFF	OFF	▶ Send module to EUCHNER for repair
Short circuit or overload detected	OFF	OFF	ON	OFF	OSSD state	CLEAR state	Flashing	Flashing	▶ Check output connections

Table 61: Troubleshooting AZ-F0408

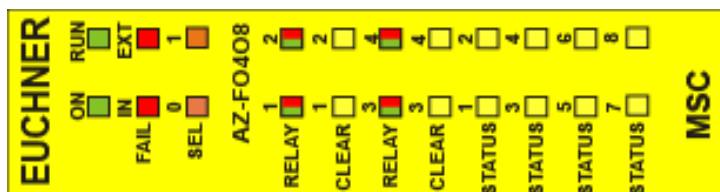

Figure 37:
AZ-F0408

8.4.11. Module O8 (Figure 38)

MEANING	LED					RECTIFICATION MEASURE
	RUN GREEN	IN FAIL RED	EXT FAIL RED	SELO/1 ORANGE	STATUS1/8 YELLOW	
Internal error	OFF	Flashes 2 or 3 times	OFF		OFF	<ul style="list-style-type: none"> Send module to EUCHNER for repair.
Compatibility error	OFF	Flashes 5 times	OFF		Flashes 5 times	<ul style="list-style-type: none"> Firmware version not compatible with MSC-CB. Send to EUCHNER for firmware upgrade.
Error during communication with base unit	OFF	Flashes 5 times	OFF		OFF	<ul style="list-style-type: none"> Restart system. If the problem persists, send module to EUCHNER for repair.
Error in another extension module or MSC-CB	OFF	ON	OFF		OFF	<ul style="list-style-type: none"> Restart system. Check which module is in the ERROR mode.
Extension module of the same type with the same address detected	OFF	Flashes 5 times	Flashes 5 times		OFF	<ul style="list-style-type: none"> Change address of the module (see section NODE_SEL)
Internal node detection error	OFF	Flashes 3 times	OFF		OFF	<ul style="list-style-type: none"> Send to EUCHNER for repair.
Short circuit or overload on status outputs 1–8	OFF	OFF	ON		Flashing	<ul style="list-style-type: none"> Check status output connections 1–8
Supply at the status outputs 1–8 missing	OFF	OFF	ON		Alternately flashing	<ul style="list-style-type: none"> Connect pin 5 to the supply

Table 62: Troubleshooting O8

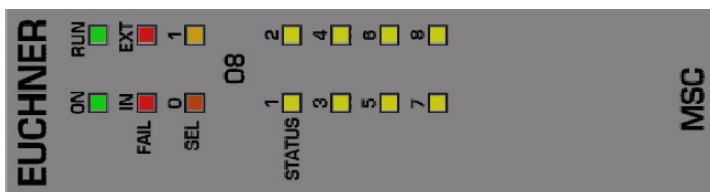

Figure 38:
O8

8.4.12. Module O16 (Figure 39)

MEANING	LED						RECTIFICATION MEASURE
	RUN GREEN	IN FAIL RED	EXT FAIL RED	SEL 0/1 ORANGE	STATUS 1/8 YELLOW	STATUS 9/16 YELLOW	
Internal error	OFF	Flashes 2 or 3 times	OFF		OFF	OFF	<ul style="list-style-type: none"> Send module to EUCHNER for repair.
Compatibility error	OFF	Flashes 5 times	OFF		Flashes 5 times	Flashes 5 times	<ul style="list-style-type: none"> Firmware version not compatible with MSC-CB. Send to EUCHNER for firmware upgrade. Restart system. If the problem persists, send module to EUCHNER for repair.
Error during communication with base unit	OFF	Flashes 5 times	OFF	Indicates the physical address of the module	OFF	OFF	<ul style="list-style-type: none"> Restart system. If the problem persists, send module to EUCHNER for repair.
Error in another extension module or MSC-CB	OFF	ON	OFF		OFF	OFF	<ul style="list-style-type: none"> Restart system. Check which module is in the ERROR mode.
Extension module of the same type with the same address detected	OFF	Flashes 5 times	Flashes 5 times		OFF	OFF	<ul style="list-style-type: none"> Change address of the module (see section NODE_SEL)
Internal node detection error	OFF	Flashes 3 times	OFF	Flashes 3 times	OFF	OFF	<ul style="list-style-type: none"> Send to EUCHNER for repair.
Short circuit or overload on status outputs 1–8	OFF	OFF	ON	OFF	Flashing	OFF	<ul style="list-style-type: none"> Check status output connections 1–8
Short circuit or overload on status outputs 9–16	OFF	OFF	ON	OFF	OFF	Flashing	<ul style="list-style-type: none"> Check status output connections 9–16
Supply at the status outputs 1–8 missing	OFF	OFF	ON	OFF	Alternately flashing	OFF	<ul style="list-style-type: none"> Connect pin 5 to the supply
Supply at the status outputs 9–16 missing	OFF	OFF	ON	OFF	OFF	Alternately flashing	<ul style="list-style-type: none"> Connect pin 6 to the supply

Table 63: Troubleshooting O16

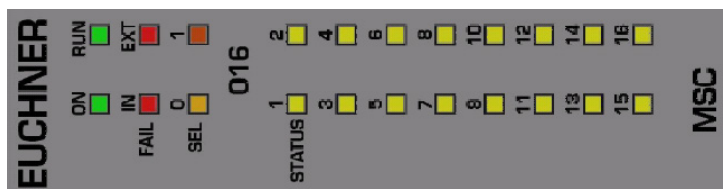

Figure 39:
O16

8.4.13. Modules SPM0, SPM1, SPM2 (Figure 40)

MEANING	LED							RECTIFICATION MEASURE
	RUN GREEN	IN FAIL RED	EXT FAIL RED	SEL ORANGE	ENC* YELLOW	PROX YELLOW	SH YELLOW	
Internal error	OFF	Flashes 2 or 3 times	OFF	Indicates the physical address of the module	OFF	OFF	OFF	<ul style="list-style-type: none"> Send module to EUCHNER for repair
Compatibility error	OFF	Flashes 5 times	OFF		Flashes 5 times	Flashes 5 times	Flashes 5 times	<ul style="list-style-type: none"> Firmware version not compatible with MSC-CB. Send to EUCHNER for firmware upgrade.
Internal error Encoder	OFF	Flashes 3 times	OFF	Flashes 3 times	Flashes 3 times	OFF	OFF	<ul style="list-style-type: none"> Replace encoder Send to EUCHNER for repair
Internal error Proximity switch	OFF	Flashes 3 times	OFF	Flashes 3 times	Flashes 3 times	Flashes 3 times	Flashes 3 times	<ul style="list-style-type: none"> Replace proximity switch Send to EUCHNER for repair
Internal error Node detection	OFF	Flashes 3 times	OFF	Flashes 3 times	OFF	OFF	OFF	<ul style="list-style-type: none"> Send module to EUCHNER for repair
Extension module of the same type with the same address detected	OFF	Flashes 5 times	Flashes 5 times		OFF	OFF	OFF	<ul style="list-style-type: none"> Change address of the module (see section NODE_SEL)
Encoder not connected but requested by configuration	OFF	OFF	Flashes 3 times**		Flashes 3 times**	OFF	OFF	<ul style="list-style-type: none"> Check connection and power supply for the encoder/proximity switch
Proximity switch not connected, but requested by configuration	OFF	OFF	Flashes 3 times**		OFF	Flashes 3 times**	OFF	<ul style="list-style-type: none"> Check input frequency (in range)

* IF SPM0 MODULE NOT FITTED
** IF ERROR ON A SINGLE CHANNEL, THE FOLLOWING ERROR INFORMATION IS INDICATED IN SUCCESSION: FIRST THE ERROR, THEN THE ERRONEOUS CHANNEL.

Table 64: Troubleshooting SPM0, SPM1, SPM2

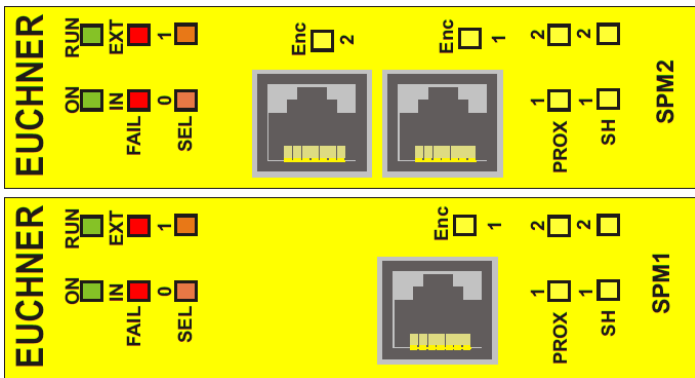

Figure 40: SPM1, SPM2

8.4.14. Module AH-FO4S08 (Figure 41)

MEANING	LED							RECTIFICATION MEASURE
	RUN GREEN	IN FAIL RED	EXT FAIL RED	SEL 0/1 ORANGE	OSSD1/4 RED/GREEN	CLEAR1/4 YELLOW	STATUS 1/8 YELLOW	
Internal error	OFF	Flashes 2 or 3 times	OFF		Red	OFF		▶ Send module to EUCHNER for repair.
Compatibility error	OFF	Flashes 5 times	OFF		Flashes 5 times	Flashes 5 times	Flashes 5 times	▶ Firmware version not compatible with MSC-CB. Send to EUCHNER for firmware upgrade.
OSSD output error	OFF	Flashes 4 times	OFF		Flashes 4 times (only the LED corresponding to the output in the ERROR mode)	OFF	OFF	▶ If the problem persists, send module to EUCHNER for repair.
Error during communication with base unit	OFF	Flashes 5 times	OFF		OFF	OFF	OFF	▶ Restart system. ▶ If the problem persists, send module to EUCHNER for repair.
Error in another extension module or MSC-CB	OFF	ON	OFF	Indicates the physical address of the module	OFF	OFF	OFF	▶ Restart system. ▶ Check which module is in the ERROR mode.
Extension module of the same type with the same address detected	OFF	Flashes 5 times	Flashes 5 times		OFF	OFF	OFF	▶ Change address of the module (see section NODE_SEL)
STATUS output overload or short circuit	OFF	OFF	ON		OUTPUT state	CLEAR	Flashing	▶ Check status output connections
OSSD overload or load connected to 24 VDC	OFF	OFF	ON		Flashing (only the LED corresponding to the output in the ERROR mode)	OFF	OUTPUT state	▶ Check OSSD output connections
No voltage on OSSD3/OSSD4	OFF	OFF	ON		OSSD3/OSSD4 flashing	OSSD3/OSSD4 flashing	OUTPUT state	▶ Connect pin 14 to 24 VDC
Node detection error	OFF	Flashes 3 times	OFF	Flashes 3 times	OFF	OFF	OFF	▶ Send module to EUCHNER for repair

Table 65: Troubleshooting AH-FO4S08

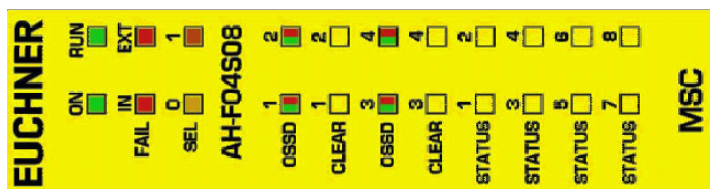

Figure 41:
AH-FO4S08

9. EUCHNER Safety Designer software

Using the “**EUCHNER Safety Designer**” (SWSD) application software, it is possible to design the logic for the safety components connected to the control system and the MSC system extensions.

The MSC base unit and the related extension modules monitor and control the connected safety components.

EUCHNER Safety Designer is based on a graphical user interface using which the connections between the various components can be defined. They are described in the following:

9.1. Installing the software

9.1.1. PC hardware system prerequisites

- › RAM: 256 MB (adequate for running Windows XP SP3 + Framework 4.0)
- › Hard disk: > 500 MB free storage capacity
- › USB connection: 1.1, 2.0 or 3.0
- › CD-ROM drive

9.1.2. PC software system prerequisites

Windows XP with Service Pack 3 (or higher) installed.



NOTICE

- › Microsoft Framework 4.0 (or higher) must be installed on the PC

9.1.3. EUCHNER Safety Designer is installed as follows

- › Insert installation CD.
- › Wait until the installation program is started by the AutoRun function.

Alternatively, change to the folder D:/.

- › Double-click the file **SetupDesigner.exe**.

After the installation is complete, a window appears in which the user is prompted to close the installation program.

9.1.4. General

If EUCHNER Safety Designer has been installed correctly, an icon is added to the desktop.

To start the program: double-click this icon. →



The following start screen is displayed:

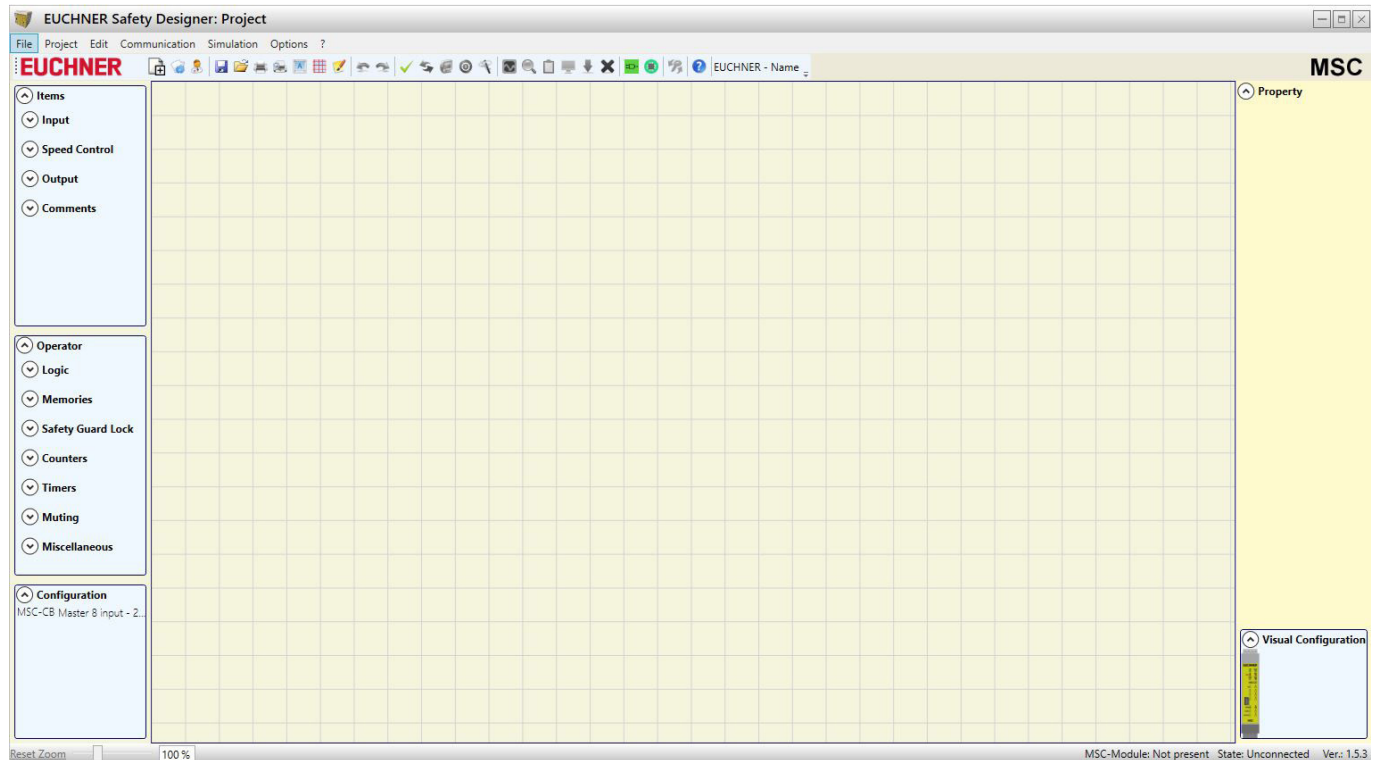

Figure 42: EUCHNER Safety Designer









You can now start to create projects.

9.1.5. Default toolbar

The default toolbar is shown in *Figure 43*. The meaning of the icons is explained in the following:



Figure 43: EUCHNER Safety Designer, default toolbar

- 1 →  CREATE NEW PROJECT
- 2 →  CHANGE CONFIGURATION (composition of different modules)
- 3 →  CHANGE USER PARAMETERS (name, company, etc.)
- 4 →  SAVE CURRENT PROJECT
- 5 →  LOAD EXISTING PROJECT (from hard disk)
- 6 →  PRINT PROJECT SCHEMATIC
- 7 →  PRINT PREVIEW
- 8 →  PRINT AREA





















- 9 →  CONNECT GRID
- 10 →  SHOW RESOURCES
- 11 →  PRINT PROJECT REPORT
- 12 →  UNDO (undo last command)
- 13 →  REDO (redo last action)
- 14 →  VALIDATE PROJECT
- 15 →  ESTABLISH CONNECTION TO MSCB
- 16 →  DISCONNECT FROM MSC
- 17 →  SEND PROJECT TO MSC
- 18 →  DOWNLOAD EXISTING PROJECT (from MSC)
- 19 →  MONITOR I/O – REALTIME STATUS – GRAPHIC
- 20 →  MONITOR I/O – REALTIME STATUS – TEXT
- 21 →  DOWNLOAD LOG FILE
- 22 →  DISPLAY SYSTEM CONFIGURATION
- 23 →  DOWNLOAD FAULT MEMORY
- 24 →  CLEAR FAULT MEMORY
- 25 →  SCHEMATIC SIMULATION
- 26 →  GRAPHIC SIMULATION
- 27 →  CHANGE PASSWORD
- 28 →  ONLINE HELP
- 29 →  RESTORE PASSWORD

Figure 44: EUCHNER Safety Designer, default icons

9.1.6. Menu bar

The menu bar can be deactivated/activated.



Figure 45: EUCNER Safety Designer, menu bar

9.1.7. Creating a new project (configuring MSCB system)

To start a new project, select the  icon on the default toolbar. The window with the project information is displayed (Figure 46).

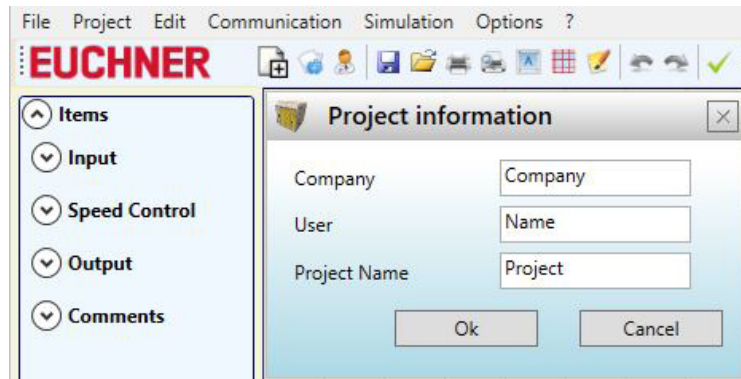
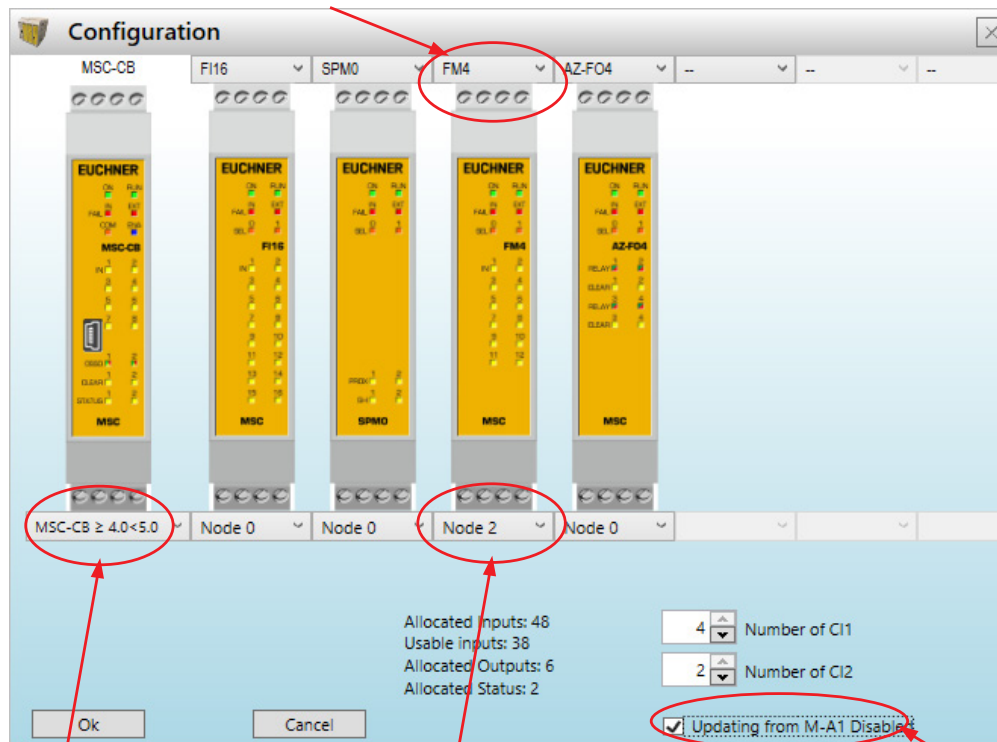

Figure 46: EUCNER Safety Designer, Project information

After opening, the MSC-CB-S module is shown. The base unit MSC-CB and the firmware versions of both base units can be selected from the drop-down menu.

You can add the modules necessary for the system using the list boxes at the top of the screen (Select extension module). The node can be selected using the list box at the bottom of the screen.

SELECT EXTENSION MODULE (to add to the configuration)



SELECTION OF FIRMWARE VERSION

SELECT NODE (from 0 to 3)

Deactivates the process of reading from the M-A1 memory card

Figure 47: EUCNER Safety Designer, selecting extension module

9.1.7.1. Changing configuration (layout of the various modules)

You can change the system configuration by selecting the  icon. The Configuration window is displayed again (Figure 47).

9.1.7.2. Editing user parameters

You can edit the project information by selecting the  icon. The window with the project information appears (Figure 46). It is not necessary to log off from ESWD for this action. As a rule, this feature is used when a new user needs to prepare a new project (also on the use of a project prepared previously).

9.1.8. Tool bars for ITEMS, OPERATOR, CONFIGURATION

Four large tool windows are displayed on the left and right side of the main window (Figure 48):

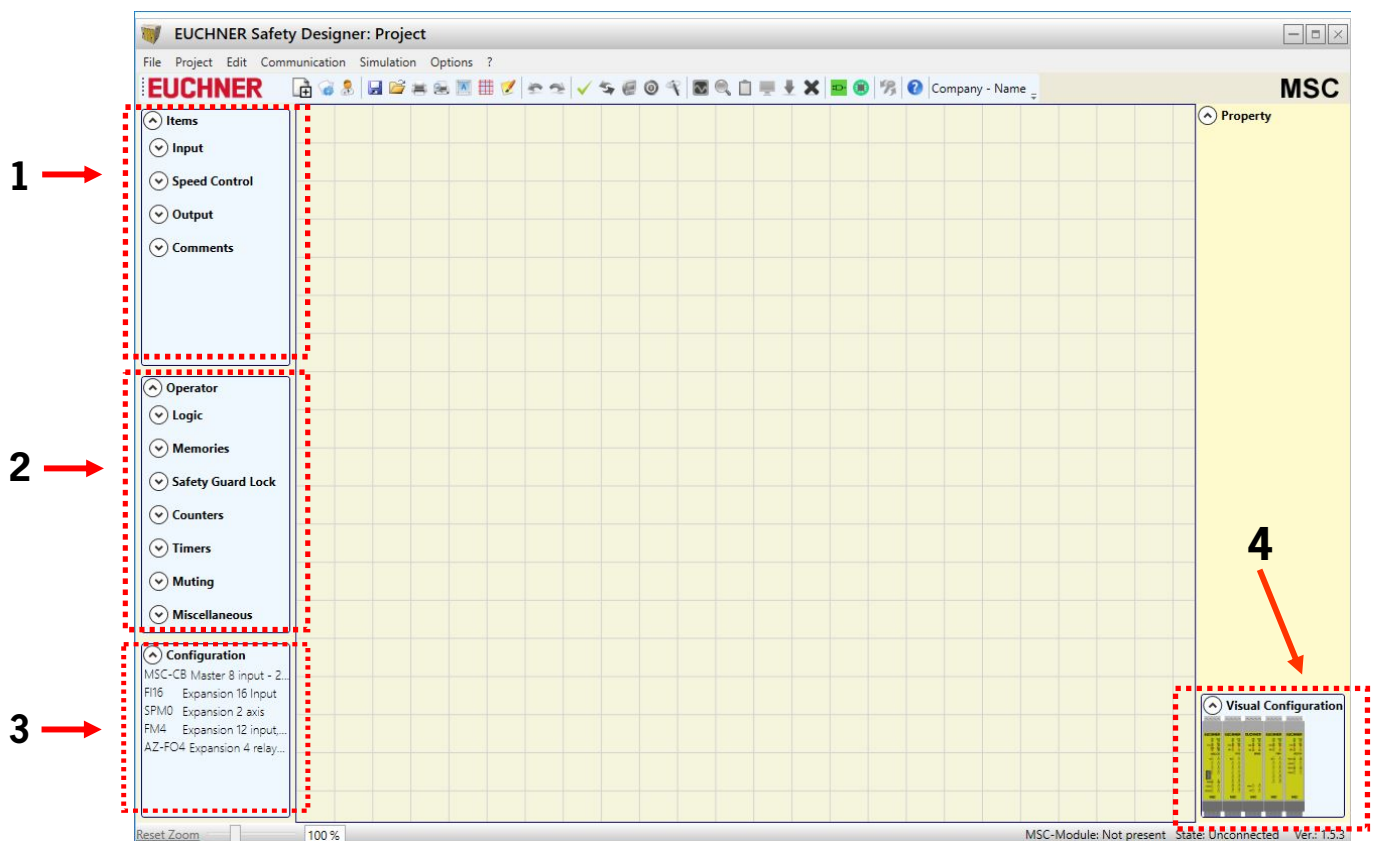

Figure 48: EUCNER Safety Designer, tool windows

1. "ITEMS" tool window

This window contains the various function blocks that make up the project. These blocks are divided into four different categories:

- Input
- Speed Control
- Output
- Comments

2. "OPERATOR" tool window

This window contains the various function blocks for linking the items in point 1. These blocks are divided into seven different categories:

- Logic
- Memories
- Safety Guard Lock
- Counter
- Timers
- Muting
- Miscellaneous

3. "CONFIGURATION" tool window

This window contains the description of the project layout.

4. "VISUAL CONFIGURATION" tool window

This window contains the graphic illustration of the project layout.

9.1.9. Preparing the diagram

After the selection of the system layout, you can configure the project.

The logic diagram is prepared with the aid of the **DRAG & DROP** function:

- Select the item required from the windows described above (the individual items are described in more detail in the following) and drag to the design workspace.
- After the selection of an item, the **PROPERTY** window is activated where you must complete the fields as necessary.
- You can set a specific numeric value on a slider (e.g. Filter) using the left and right arrow keys on the keyboard, or by clicking the ends of the slider.
- Items can be linked together by selecting the required pin using the mouse and then dropping the link on the pin to be connected using drag & drop.
- You can make connections between elements a long way apart using the "Interpage In/Out" component under "Operator/Miscellaneous". A name must be assigned to the "Interpage Out" element; this name must correspond to the related "Interpage In" element to create the required connection.

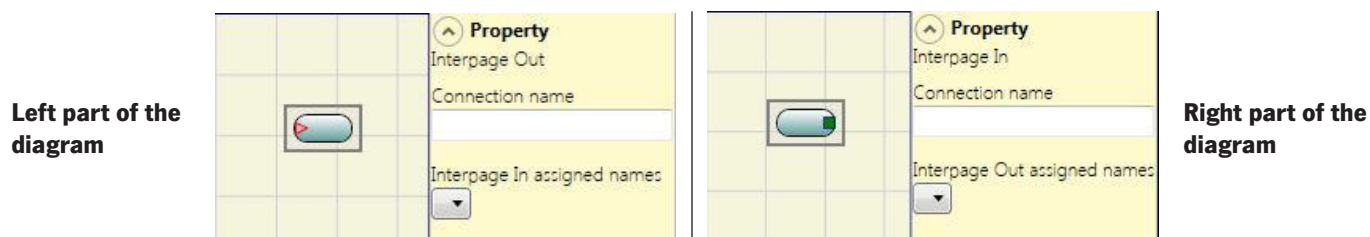

Figure 49: Interpage In/Out

- If an item needs to be duplicated, first you must select it and then you can copy and paste it by pressing CTRL+C/ CTRL+V on the keyboard.
- An item or a link is deleted by selecting the item or the link and then pressing DEL on the keyboard.

9.1.9.1. Using the right mouse button

- On input/output blocks
 - Copy/paste
 - Delete
 - Delete all assigned connections
 - Alignment with other function blocks (with multiple selection)
 - Help
 - Monitor mode: show/hide the property window
 - Status block: activate/deactivate the logical negation on the input pin
- On operator blocks
 - Copy/paste
 - Delete
 - Alignment with other function blocks (with multiple selection)
 - Help
 - Activate/deactivate the logical negation
 - Monitor mode: show/hide the property window
- On terminals
 - Alignment with other function blocks (with multiple selection)
- On connections (wires)
 - Delete
 - Indication of the entire path for a connection (network)

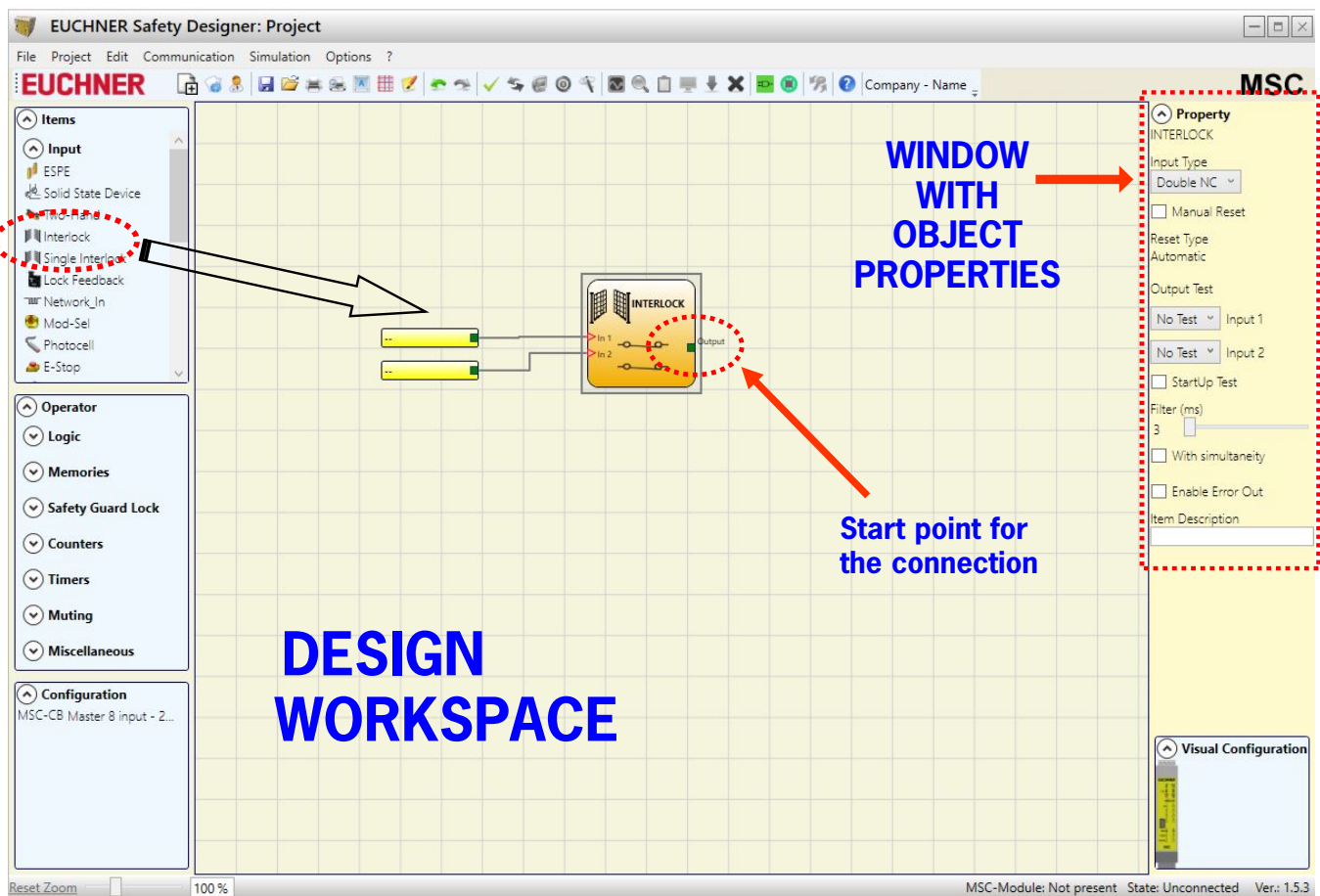

Figure 50: EUCHNER Safety Designer, design area

9.1.10. Example for a project

Figure 51 shows an example of a project in which the module MSC-CB is connected to only two safety components (interlock and emergency stop).

The inputs (1, 2, 3) on the module MSC-CB for connecting the contacts on the safety components are highlighted in yellow on the left. The MSC outputs (from 1 to 4) are activated as per the conditions that are specified in the interlock (INTERLOCK) and emergency stop (E-STOP) (see Page 98 Emergency stop (E-STOP) and Page 99 Interlock (INTERLOCK)).

Click a block to select it and activate the PROPERTY window on the right where you can configure the activation and test parameters for the block.

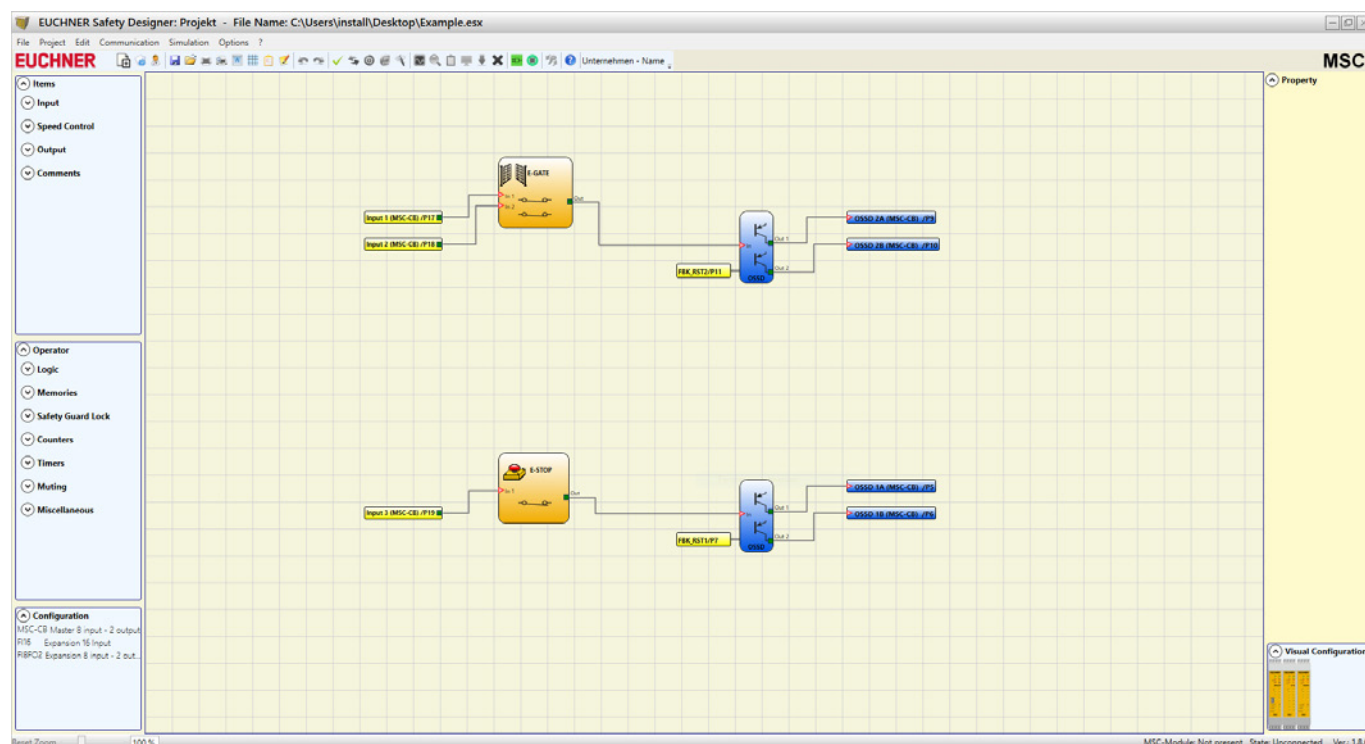

Figure 51: EUCHNER Safety Designer, project example

At the end of the project preparation phase (or during intermediate steps), you can save the current configuration using the



icon on the default toolbar.

9.1.10.1. Project validation



NOTICE

The completed project must now be validated.

This check is made by running the VALIDATE command ( symbol on the default toolbar).

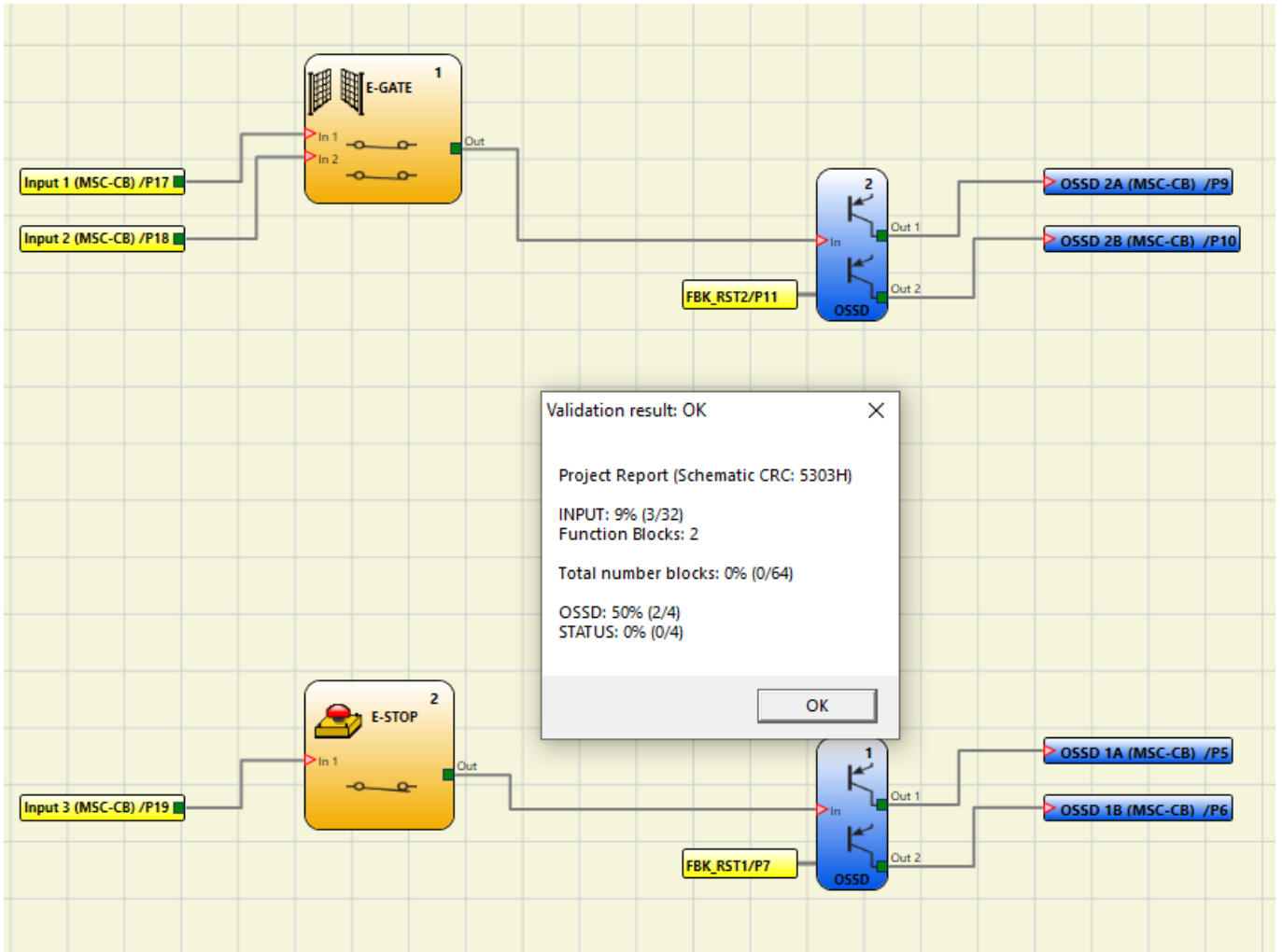

Figure 52: EUCNER Safety Designer, project validation

If the validation is successful, a sequential number is assigned to the INPUT and OUTPUT on the diagram. This number then appears also in the REPORT and in the monitor in EUCNER Safety Designer. The configuration can be transferred only after successful validation.



WARNING

The validation function checks only whether the programming is appropriate for the properties of the MSC system. However, this check does not guarantee that the device has been programmed such that all safety requirements for the application are met.

9.1.10.2. Resources allocation

The resources allocation can be shown by selecting the  icon. All elements used, such as inputs, outputs, status, fieldbus inputs and fieldbus outputs, are shown in the resources allocation.

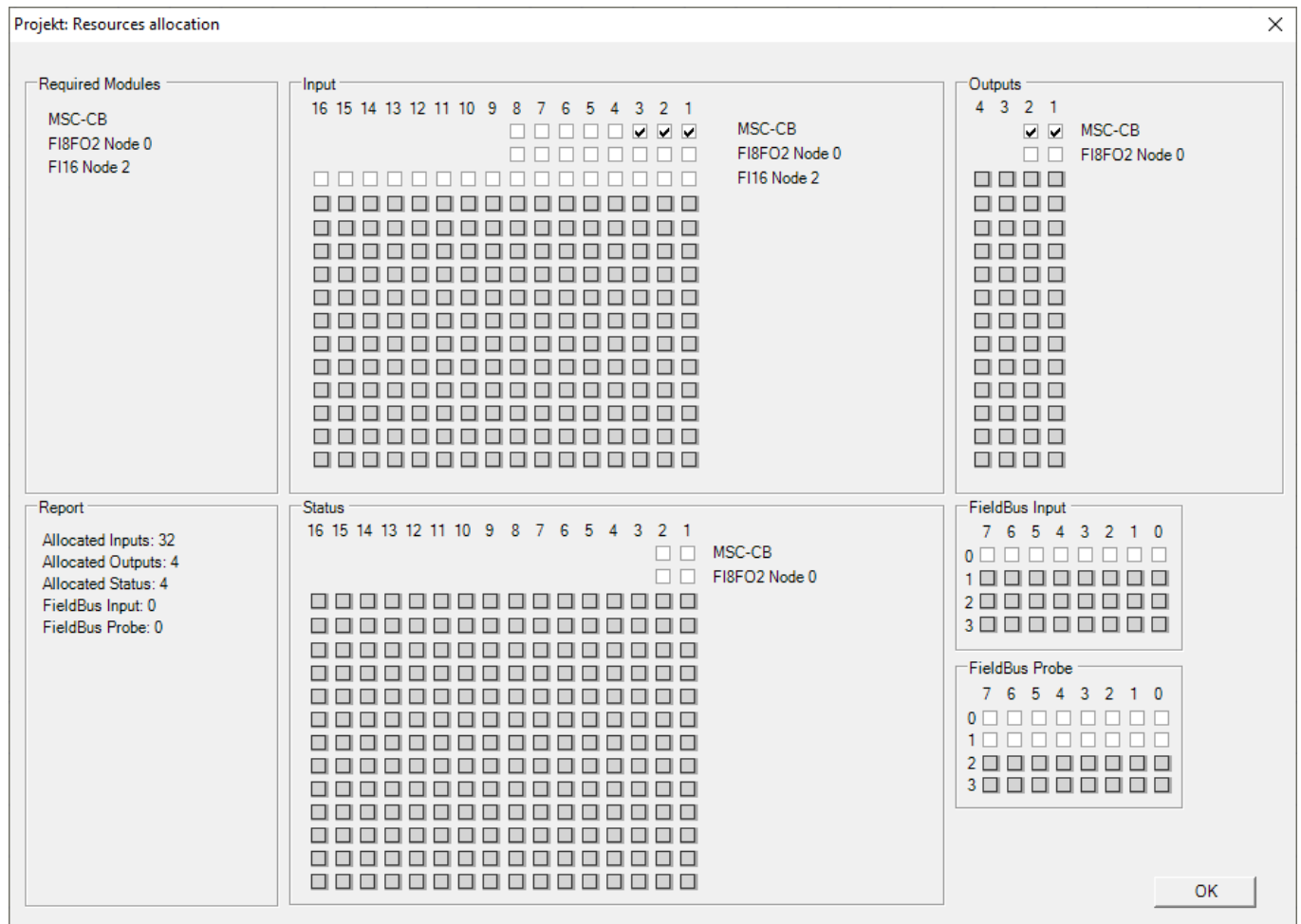

Figure 53: EUCNER Safety Designer, resources allocation

9.1.10.3. Print report

The system layout can be printed together with the properties of the individual blocks ( icon on the default toolbar).

MSC

Project Report generated by EUCHNER Safety Designer Ver.: 1.8.0

Project Name: Projekt
User: Name
Company: Unternehmen
Date: 22.09.2020 08:20:30
Schematic CRC: 5303H
File Name: C:\Users\install\Desktop\Example.esx

1

MSC-Module: Configuration
Module MSC-CB (Configured Firmware version: FW >= 3.0 <4.0)
Module FI16 Node 2 (Minimum Required Firmware version: 0.1)
Module FI8FO2 Node 0 (Minimum Required Firmware version: 0.1)
Updating from M-A1 Disabled: False
Cycle Time (ms) = 3,736

2

MSC-Module: Safety Information
PFHd (according to IEC 61508): 2,03E-008 (1/h)
MTTFd (according to EN ISO 13849-1): 143 years
DCavg (according to EN ISO 13849-1): 99.00 %

3

Attention!

This definition of PL and of the other related parameters as set forth in EN ISO 13849-1 only refers to the functions implemented in the MSC-Module system by the MSC configuration software, assuming configuration has been performed correctly. The actual PL of the entire application and the relative parameters must consider data for all the devices connected to the MSC-Module system within the scope of the application. This task and any other aspect of system configuration are the exclusive responsibility of the user/installer.

The final MTTFd value, taking in account data for all the devices connected to the system, must always be saturated to 100 years if over.

Resources used
INPUT: 9% (3/32)
Function Blocks: 2
Total number blocks: 0% (0/64)
OSSD: 50% (2/4)
STATUS: 0% (0/4)

4

Electrical diagram

E-Gate

Function Block 1
Filter (ms): 3
Double NC
Reset Type: Automatic
StartUp Test: False
Connections:
In1: MSC-CB INPUT1/Terminal17
In2: MSC-CB INPUT2/Terminal18

E-Stop

Function Block 2
Filter (ms): 3
Single
Reset Type: Automatic
StartUp Test: False
Connections:
In1: MSC-CB INPUT3/Terminal19

OUTPUT1: OSSD SIL3/PL e
Reset Type: Automatic
Response time: 16,498 ms
Dependence on inputs:
Function Block 2
Connections:
MSC-CB OSSD1A/Terminal5
MSC-CB OSSD1B/Terminal6
MSC-CB Fbk: Terminal7
OUTPUT2: OSSD SIL3/PL e
Reset Type: Automatic
Response time: 16,498 ms
Dependence on inputs:

5

Function Block 1
Connections:
MSC-CB OSSD2A/Terminal9
MSC-CB OSSD2B/Terminal10
MSC-CB Fbk: Terminal11

Signature _____

EUCHNER

1. Total CRC
2. Cycle time
3. Information about the safety level
4. Resources used
5. OSSD reaction time

Figure 54: EUCHNER Safety Designer, project report

	<p>WARNING</p> <ul style="list-style-type: none"> ▸ This definition of the PL and the other related parameters as per EN ISO 13849-1 relates only to the functions that have been implemented by EUCHNER Safety Designer in the MSC system; here it is assumed that the configuration has been performed correctly. ▸ The data for all devices connected to the MSCB in the application must be taken into account in the actual PL for the entire application and the related parameters. ▸ This task is allowed to be performed only by the design engineer or the installer.
---	---

9.1.10.4. Connecting to MSC

	<p>NOTICE</p> <p>A remote connection is possible with a base unit firmware version from 3.0.1. To establish a connection to the MSC, the USB connection of the base unit is accessed via an Ethernet adapter.</p>
---	--

Once the base unit has been connected to the PC via the USB cable, a connection must be established using the  icon. A window with a password prompt appears. Type password (see "Password protection").

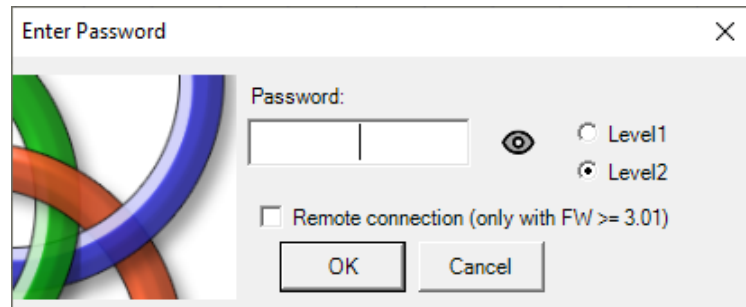



Figure 55: EUCHNER Safety Designer, password prompt

9.1.10.5. Sending the configuration to the MSC system

Click the  icon on the default toolbar to send the saved configuration from the PC to MSC-CB/MS-CB-S after the related command is executed. In the MSC-CB/MS-CB-S, the project is saved in the internal memory and (if fitted) on the M-A1 memory card (password required: level 2).

	<p>NOTICE</p> <p>This function is available only after the successful validation of the project.</p>
---	---

9.1.10.6. Downloading a configuration file (project) from the base unit



Click the  icon on the default toolbar to download a project from the base unit MSC-CB/MSC-CB-S to the EUCHNER Safety Designer configuration software. EUCHNER Safety Designer displays the project saved in MSC-CB/MSC-CB-S (required password: level 1).



NOTICE

- › If the project is to be used for other modules of type MSC-CB/MSC-CB-S, the components connected in each case are to be checked (see “System layout” on page 85).
- › Then, a “Project validation” (Page 80) and “Checking the system” (Page 89) are to be performed.

9.1.10.7. Configuration log



NOTICE

- › The creation date and the CRC (four-digit hexadecimal code) for a project saved in the MSC-CB/ MSC-CB-S are contained in the configuration file (project) (Figure 56).
- › Up to five sequential events can be recorded in this log. Then the results are overwritten starting with the oldest event.

The log file (LOG) can be displayed using the  icon on the default toolbar (password required: level 1).

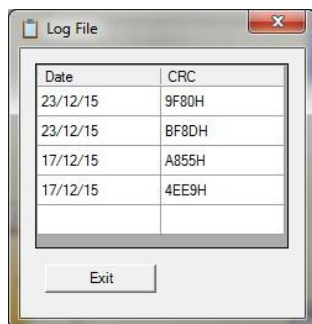



Figure 56: EUCHNER Safety Designer, log file

9.1.10.8. System layout

The current layout of the MSC system can be checked using the  icon (password required: level 1). A table with the following content appears:

- › Connected modules;
- › Firmware version installed in the individual modules;
- › Node number (physical address) of the individual modules.

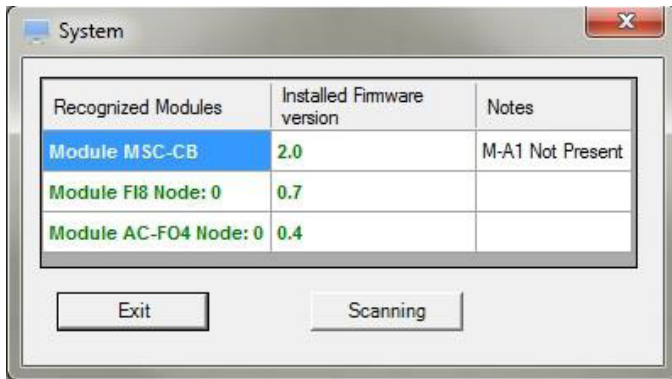

Figure 57: Overview of system layout

If there is an error in one of the modules detected, the following window appears.

In the example below the node number of module FI8 is not correct (indicated by red text).

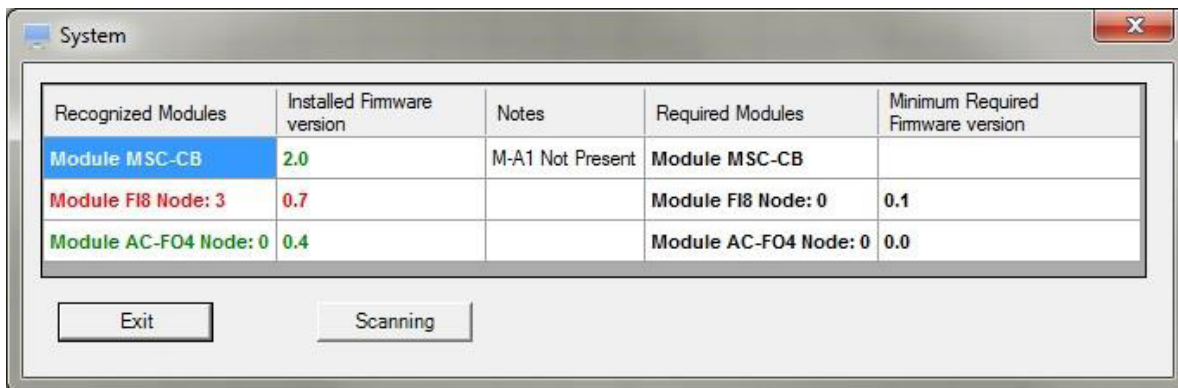



Figure 58: Erroneous system layout

9.1.10.9. Disconnecting the system

Click the  icon to disconnect the PC from the base unit. After disconnection, the system is reset and restarted with the transferred project.



NOTICE

If the system does not comprise all the modules designated in the configuration, this discrepancy is indicated on the MSC-CB/MS-CB-S module and the module is not started (see SIGNALS).

9.1.10.10. Monitor (real-time I/O status – text form)



Click the icon to activate the monitor (password required: level 1). A pop-up window with the following content appears **(in real time)**:

- › Status of the inputs (if the item has two or more input connections to MSC, only the first is indicated in the monitor as active; see example shown)
- › Input diagnostic
- › OSSD state;
- › OSSD diagnostics;
- › Status of the digital outputs;
- › OUT_TEST diagnostics.

Module	block	Notes	INPUT	State	Input diagnostic	Module	OSSD	State	OSSD diagnostic	Module	Status	State	Diag Status
MSC-CB	1	Interlock	IN1	OFF		MSC-CB	OSSD1	OFF			X		
			IN2			MSC-CB	OSSD2	ON			X		
MSC-CB	2	E-Stop	IN3	ON			X				X		
			X				X				X		
			X				X				X		
			X				X				X		
			X										
			X										
			X										
			X										
			X										
			X										
			X										
			X										
			X										

Exit

Figure 59: Monitor (text form)

9.1.10.11. Monitor (real-time I/O status – text – graphic)

Click the  icon to activate/deactivate the monitor (password required: level 1). Based on the color of the links (Figure 60) the diagnostics can be read (in real time) as follows:

- › **RED** = OFF
- › **GREEN** = ON
- › **DOTTED ORANGE** = Connection error
- › **DOTTED RED** = ENABLE present (e.g. RESTART)

SPECIAL CASES

- ➔ “NETWORK” OPERATOR, “NETWORK IN” and “NETWORK OUT” signals:
- › **THICK CONTINUOUS RED LINE** = STOP
- › **THICK CONTINUOUS GREEN LINE** = RUN
- › **THICK CONTINUOUS ORANGE LINE** = START
- ➔ “SERIAL OUTPUT” OPERATOR:
- › **THICK CONTINUOUS BLACK LINE** = Data transmission

You can display the diagnostics by positioning the mouse pointer on the link.

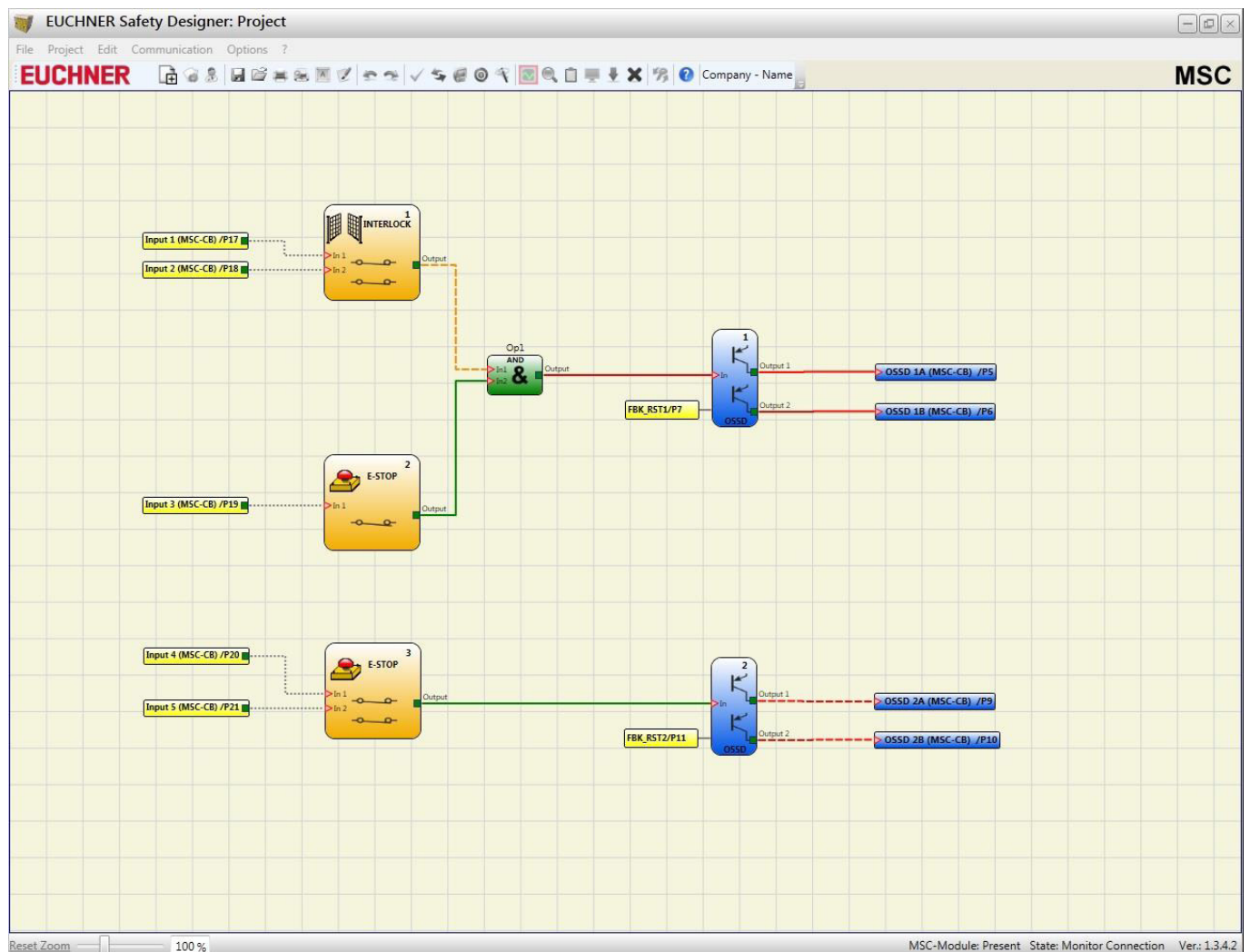

Figure 60: Monitor (graphic)

9.1.11. Password protection

To upload and save the project, you must enter a password in EUCHNER Safety Designer.



NOTICE

The default password must be changed to prevent tampering (password level 2) or so that the configuration loaded in the MSC is not visible (password level 1).

9.1.11.1. Password level 1

All operators who use the MSC system must have a level 1 PASSWORD.

Using this password it is possible to display only the LOG file, the layout of the system, the real-time monitor and the upload processes.

On the initialization of the system for the first time, the operator must use the password "" (ENTER key). System planners who know the level 2 password can assign a new password for level 1 (alphanumeric, max. 8 characters).



NOTICE

Operators who know this password are **authorized** to upload the project (from MSC-CB/MS-CB-S to PC), to edit it or to save it.

9.1.11.2. Password level 2

System planners who are authorized to work on the preparation of the project must know the level 2 PASSWORD. On the initialization of the system for the first time, the operator must use the password "**SAFEPASS**" (upper case).

System planners who know the level 2 password can assign a new password for level 2 (alphanumeric, max. 8 characters).



NOTICE

- › Using this password, the project **can** be uploaded (from PC to MSC-CB/MS-CB-S), edited and saved. In other words, complete control of the PC => MSC system is possible using this password.
- › On UPLOADING a new project, you can change the level 2 password.
- › Should one of these passwords no longer be available, please contact EUCHNER to request an

unlock file (if the unlock file is saved in the correct folder, the  icon appears on the toolbar). Press the icon to reset the level 1 and 2 passwords to their original values. This password is provided only to the system planner and can be used only once.

9.1.11.3. Password change

Click the  icon to change the PASSWORD after the connection has been established using the level 2 password.

A window (Figure 61) appears in which the new password can be selected. Type old and new password in the related fields (max. 8 characters). Click OK.

At the end of the process, disconnect to restart the system.

If an M-A1 memory card is fitted, the new password is also saved on this memory card.

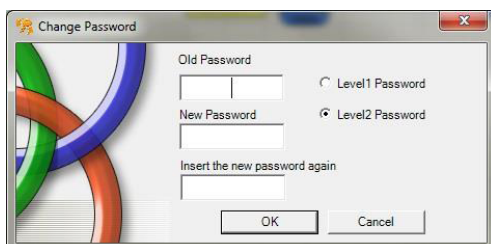

Figure 61: Password change

9.1.12. Checking the system



WARNING

The system must be checked for correct operation after the project has been validated and uploaded to the MSC-CB/MS-CB-S module and all safety components have been connected.

This check is made by forcing a status change for each safety component connected to MSC to check whether the status of the outputs also actually changes.

The following example is intended to explain the CHECK process.

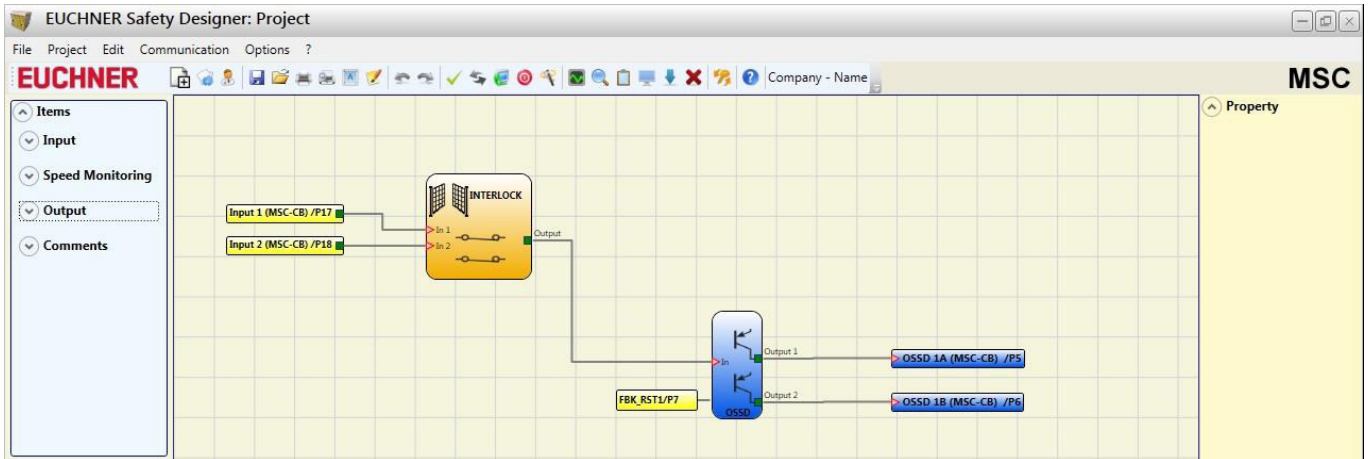

Figure 62: Checking the system

(t1) In the normal operating status (interlock (INTERLOCK)), Input1 is closed, Input2 is open and the INTERLOCK output set to the “High” logic level. In this mode the safety outputs (OSSD1/2) are active and a supply voltage of 24 VDC is present at the related terminals.

(t2) If the interlock (INTERLOCK) is opened **physically**, the state of the inputs changes and therefore also the outputs of the INTERLOCK block: (OFF = 0 VDC → 24 VDC); **the state of the safety outputs OSSD1/2 changes from 24 VDC to 0 VDC**. If this change is detected, the movable interlock (INTERLOCK) is connected correctly.

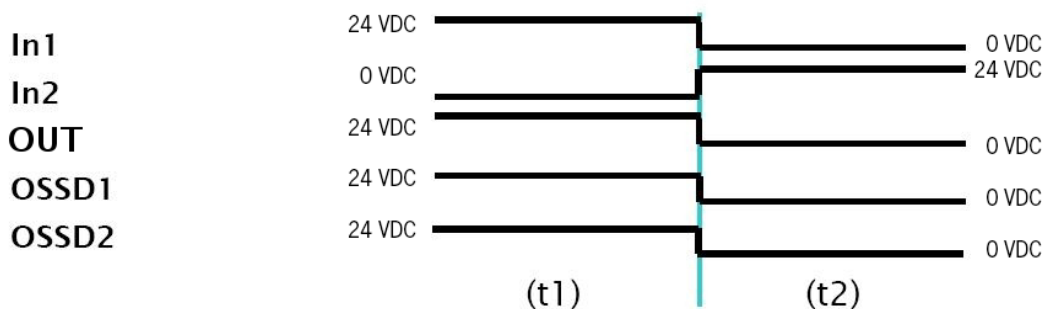

Figure 63: Change in the state of the system inputs/outputs



WARNING

- › You will find more detailed information on the correct installation of external sensors/components in the installation manual.
- › This check must be performed for each safety component in the project.

9.2. Item-specific function blocks

9.2.1. Output items

9.2.1.1. Safety outputs (OSSD)

The OSSD outputs do not require any maintenance. Output1 and Output2 supply 24 VDC with an input of “1” (TRUE) and 0 VDC with an input of “0” (FALSE).

➔ Each OSSD pair has a corresponding RESTART_FBK input. This input must always be connected as described in the paragraph RESTART_FBK.

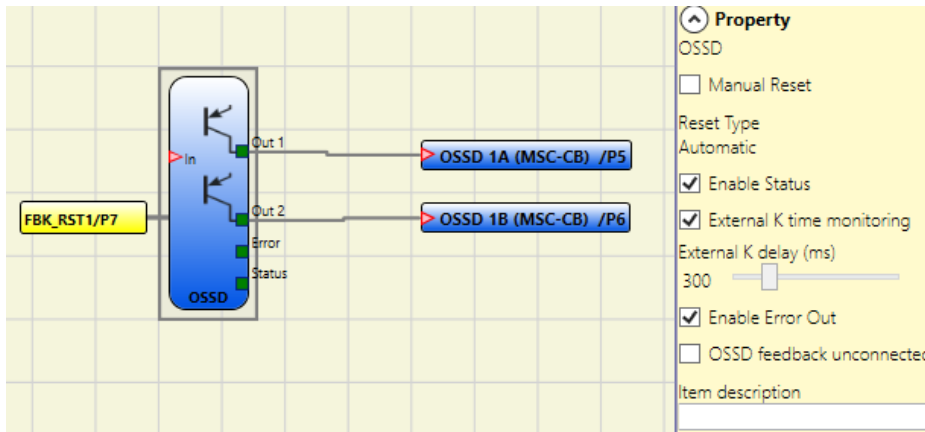

Figure 64: OSSD (safety outputs)

Parameters

Manual Reset: If selected, a reset can be requested on every change in the input signal. Otherwise, activation of the output will correspond directly to the input conditions.

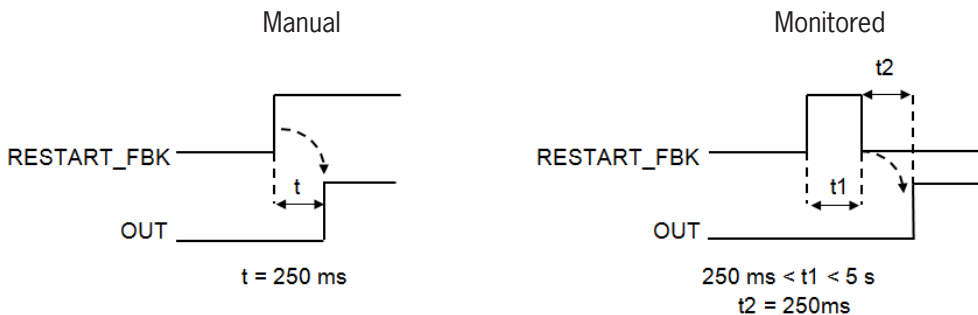

Figure 65: OSSD parameters

There are two types of reset: “Manual” and “Monitored.” On the selection of manual reset, the system checks only the signal transition from 0 to 1. With monitored reset, the double transition from 0 to 1 and then back to 0 is checked.

Enable Status: If activated, the OSSD can be connected to a STATUS.

External K time monitoring: If activated, the time window for monitoring the external feedback signal (on the state of the output) can be set.

If the OUTPUT is at logic level “High” (TRUE), the FBK signal must be at the logic level “Low” (FALSE) within the time set and vice versa.

Otherwise, the OUTPUT output changes to the Low level (FALSE) and the error is signaled on the base unit MSC-CB/MSC-CB-S by the flashing of the CLEAR LED for the OSSD in the error mode.

Enable Error Out: If activated, the ERROR_OUT output is enabled. **If an error is detected on the external FBK signal, the output changes to the logic level “High” (TRUE).**

The **Error OUT** signal is reset if one of the following events occurs:

1. The system is switched off and on again.
2. Activation of the RESET operator.

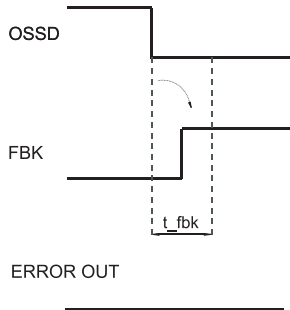

Figure 66: Example for OSSD with correct feedback signal: in this case ERROR OUT=FALSE

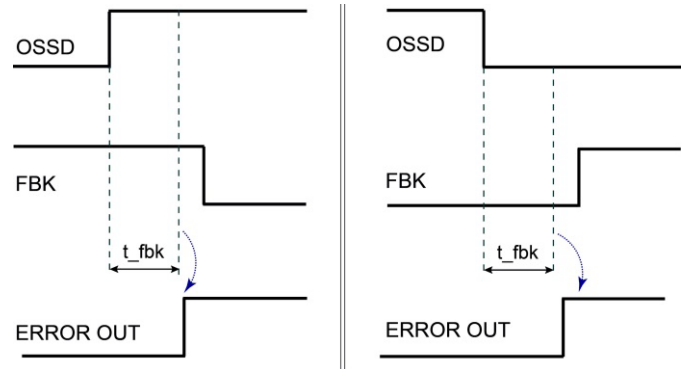

Figure 67: Example for OSSD with erroneous feedback signal (external switching time exceeded): In this case, ERROR OUT=TRUE

OSSD feedback unconnected: If selected, the RESTART_FBK input does not have to be connected. Otherwise, the feedback loop must be connected directly to 24 V or the positively driven contact must be fed back.

9.2.1.2. Safety output (single-double OSSD)

The OSSD safety output does not require any maintenance.

Output1 supplies 24 VDC with an input of "1" (TRUE) and 0 VDC with an input of "0" (FALSE).

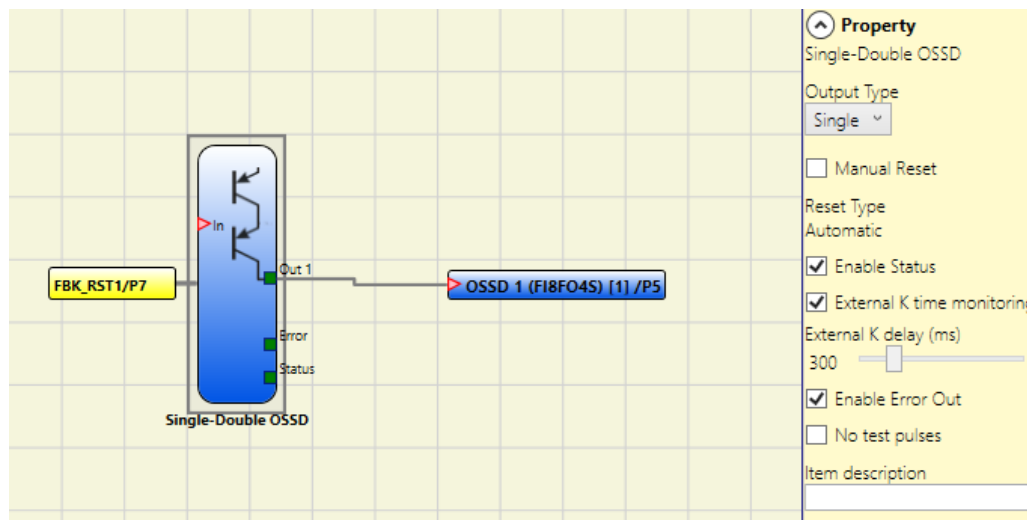

Figure 68: Single-double OSSD

- ➔ Each SINGLE_OSSD output has a corresponding RESTART_FBK input. The RESTART_FBK input appears for OSSD outputs of the MSC-CB-S and F18FO4S modules only if manual reset or feedback loop monitoring is activated. The RESTART_FBK input is mandatory on the AH-FO4S08 module and must be connected as described in the RESTART_FBK section.

Parameters

Output type: two different output types are available:

- › Single output
- › Double output

The operator can choose from the following configurations using the MSC-CB-S, FI8FO4S and AH-F04S08 modules:

1. Four OSSD function blocks (single output)
2. Two OSSD function blocks (double output)
3. Two OSSD function blocks (single output) + one OSSD function block (double output)

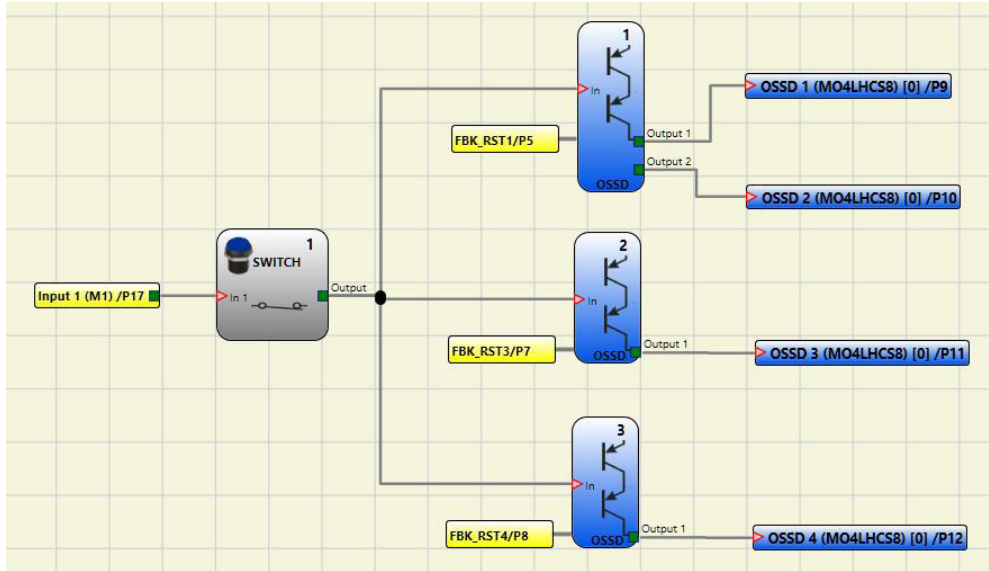

Figure 69: Example for a project: 2 blocks with single output + 1 block with double output

The possible configurations of the MSC-CB-S, FI8FO4S, AH-F04S08 (2 or 4 OSSD) modules are shown below:

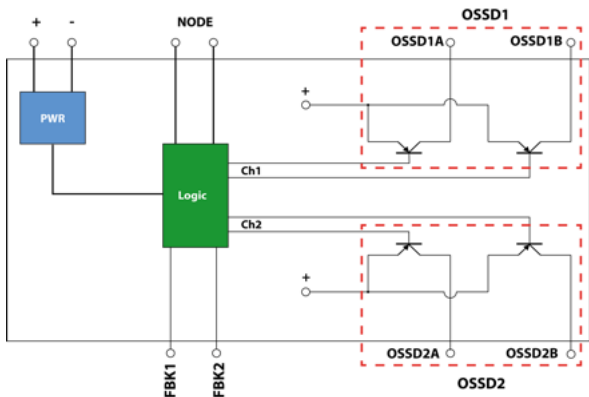

Figure 70: Configuration of 2-channel outputs (category 4)

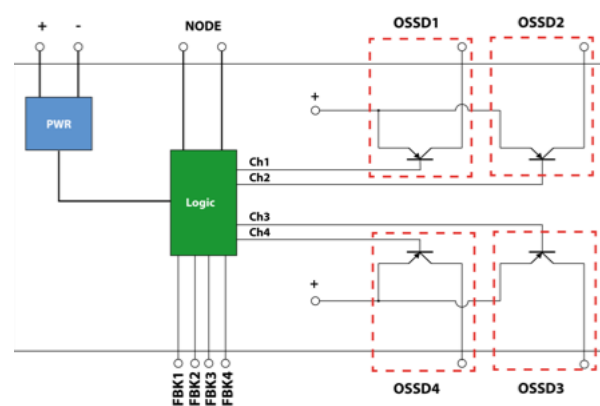

Figure 71: Configuration of 4 single-channel outputs (category 4)

Manual Reset: If selected, a reset can be requested each time the IN input signal drops out. Otherwise, activation of the output follows the input conditions directly.

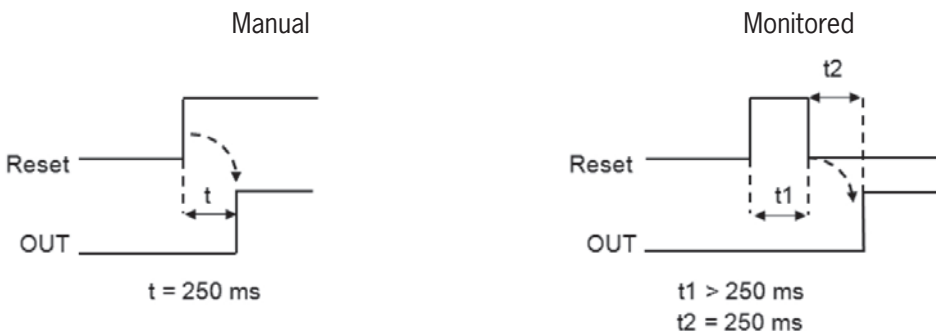

Figure 72: Manual/monitored reset

There are two types of reset: Manual and Monitored. On the selection of manual reset, only the signal transition from 0 to 1 is checked. With monitored reset, the double transition from 0 to 1 and then back to 0 is checked.

Enable Status: If activated, the current status of the OSSD can be connected to any point in the diagram.

External K time monitoring: If activated, the time window for monitoring the external feedback signal (on the state of the output) can be set.

If the OUTPUT is at logic level "High" (TRUE), the FBK signal must be at the logic level "Low" (FALSE) within the time set and vice versa.

Otherwise, the OUTPUT output changes to the Low level (FALSE) and the error is signaled on the base unit MSC-CB by the flashing of the CLEAR LED for the OSSD in the error mode.

Enable Error Out: If activated, the ERROR_OUT output is enabled. **If an error is detected on the external FBK signal, the output changes to the logic level "High" (TRUE).**

The **Error OUT** signal is reset if one of the following events occurs:

1. The system is switched off and on again.
2. Activation of the RESET MSC-CB operator.

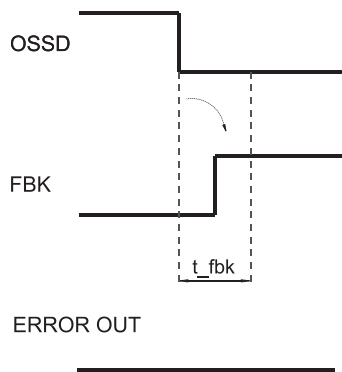

Figure 73: Example for OSSD with correct feedback signal: in this case ERROR OUT=FALSE

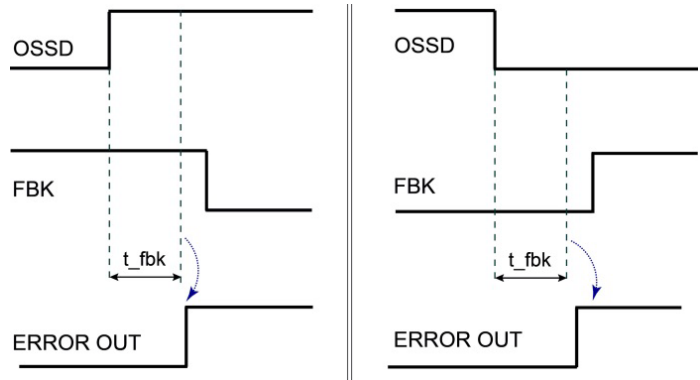

Figure 74: Example for OSSD with erroneous feedback signal (external switching time exceeded): In this case, ERROR OUT=TRUE

No test pulse: If activated, no test pulses will be transmitted via the output.



NOTICE

The SIL decreases from 3 to 2 when this parameter is activated.

9.2.1.3. Signal output (STATUS)

Using the STATUS output, every point in the diagram can be monitored by connecting it to the In input. The output supplies 24 VDC with an input of "1" (TRUE) or 0 VDC with an input of "0" (FALSE).

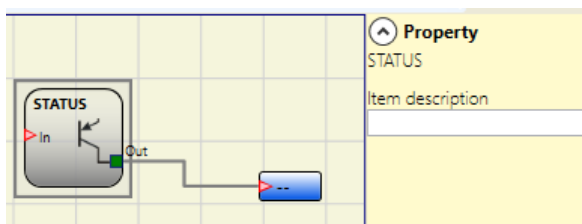

Figure 75: Status



Important!

The STATUS output is **NOT** a safety output.

9.2.1.4. Fieldbus output (FIELDBUS PROBE)

Using this element, the status of any point on the diagram can be indicated on the fieldbus.

The respective bit must be selected to perform changes on the output. The following table shows the max. number of sensors.

Base unit	Fieldbus module firmware	No. of sensors
MSC-CB-S	≥ 2.0	Max. 32
MSC-CB-S	< 2.0	Max. 16
MSC-CB	Independent	Max. 16

Table 66: Max. number of sensors at the fieldbus output

The states are indicated on the fieldbus using four bytes. (You will find more detailed information in the fieldbus manual on the CD ROM “EUCHNER Safety Designer.”)

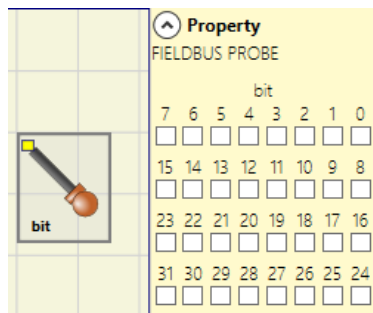

Figure 76: Fieldbus output



Important!

The fieldbus output is **not** a safety output.

9.2.1.5. Relay [RELAY]

The output relay is a relay output with a normally open contact. The relay outputs are closed if the **IN** input is “1” (TRUE), otherwise the contacts are open (FALSE).

Parameters

Category: There are three categories of relay outputs:

Category 1. Outputs with a category 1 relay. Each AZ-F04/AZ-F0408 module can have up to four outputs.

Properties:

- › Internal relays are monitored.
- › External device monitoring contacts (EDM, check on FBK 1-4) are not used (not required for category 1).
- › Each output can be set to manual or automatic starting.

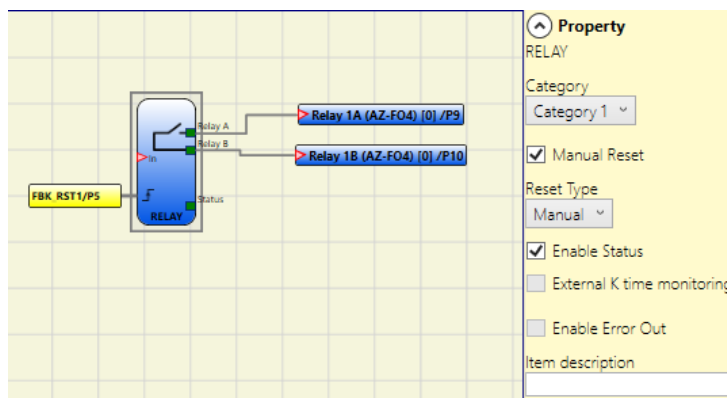
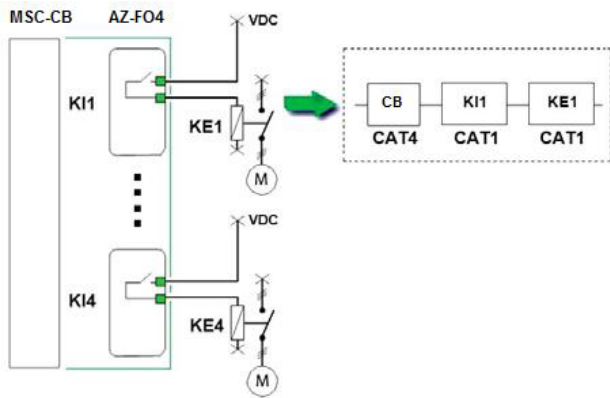

Figure 77: Relay output

Example of use with external relay



Example of use with only internal relay

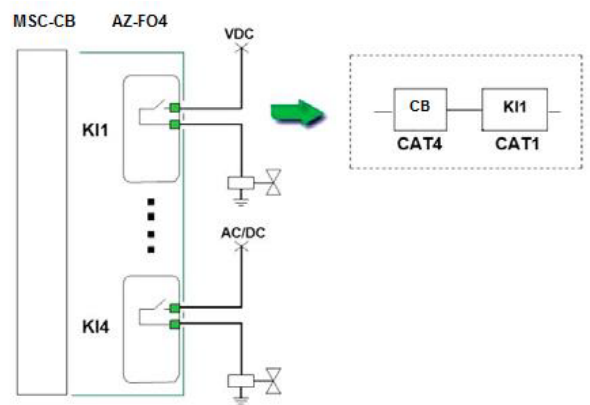

Figure 78: Examples of use

Category 2. Outputs with a category 2 relay with OTE (Output Test Equipment) outputs. Each AZ-FO4/AZFO408 module can have up to four outputs.

OTE: The OTE (Output Testing Equipment) output is normally “1” (TRUE), except if there is an internal error or a malfunction in conjunction with the feedback loop for external contactors (FALSE).

Properties:

- › Internal relays are always monitored.
- › Monitored external device monitoring contacts (EDM).
- › The output can be configured for a manual or automatic restart. The external device monitoring (EDM) cannot be activated with a manual start, only with an automatic start. If, however, a manual start is required with external device monitoring, special logic must be used (see information below).

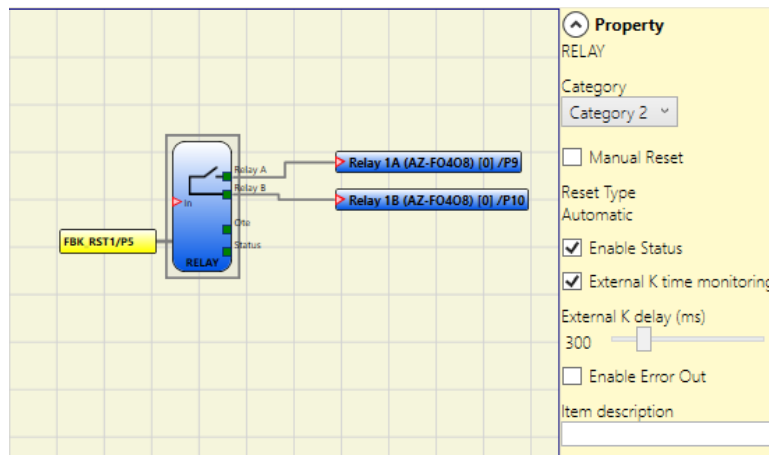

Figure 79: Relay output cat. 2

Output for the OTE (Output Test Equipment)

- › Activation: This is necessary for category 2 configurations for signaling dangerous failures as per EN 13849-1: 2006/DAM1 (in preparation).
- › OTE output: normally ON.
If there is a fault in the internal feedback or the external device monitoring (EDM) -> OFF.
This signal makes it possible to stop hazardous movements, or at least to indicate the fault to the operator.

Use of the automatic start (A) or manual start (B) (category 2)

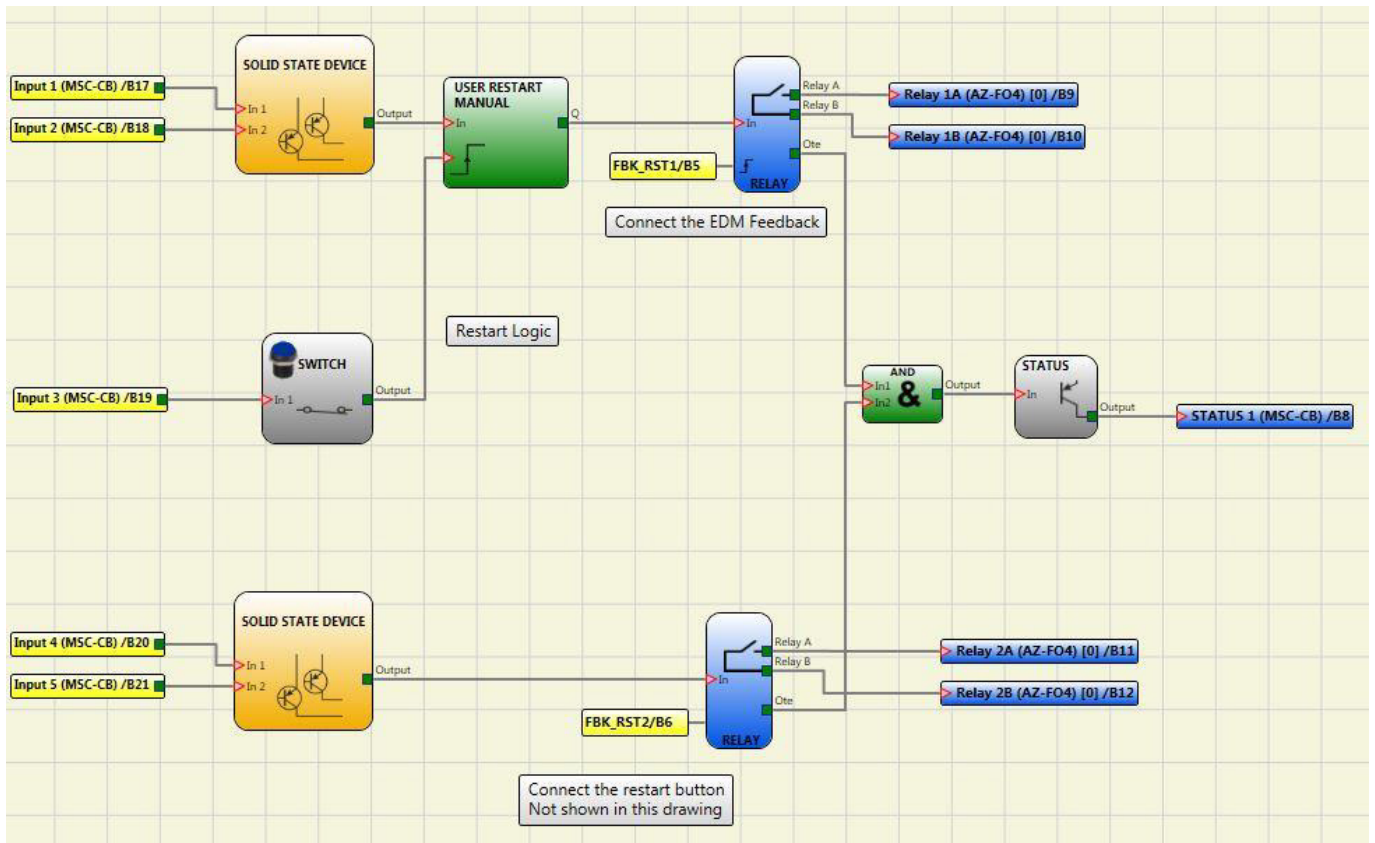

Figure 80: Use of the automatic or manual start

Category 4. Outputs with two category 4 relays. Each AZ-FO4/AZ-FO408 module can have up to two outputs of this type. The relays are operated in pairs for this output.

Properties:

- › 2 dual-channel outputs.
- › Double internal relays are monitored.
- › The output can be configured for a manual or automatic restart.

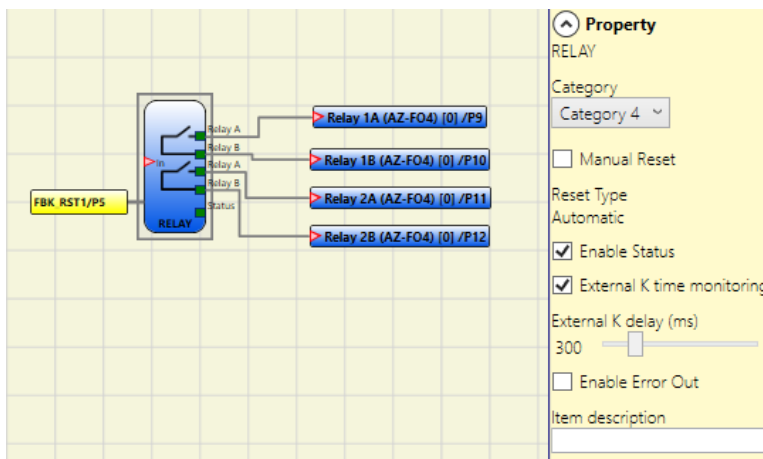

Figure 81: Relay output cat. 4



NOTICE

To avoid affecting the result of the calculation of the PL, the inputs (sensors or safety components) must correspond to the same or a higher category as the other devices in the chain.

Example of use with only the internal relay and monitored solenoid valves

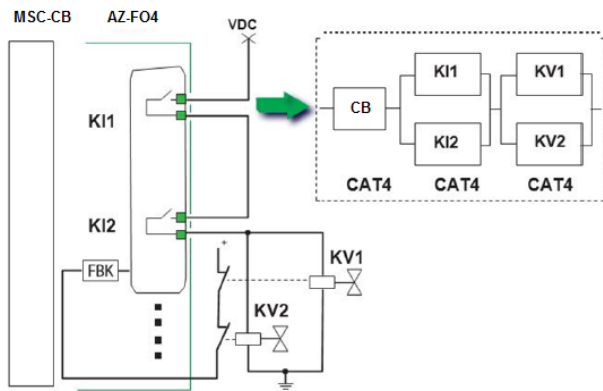

Example of use with external contactors with feedback

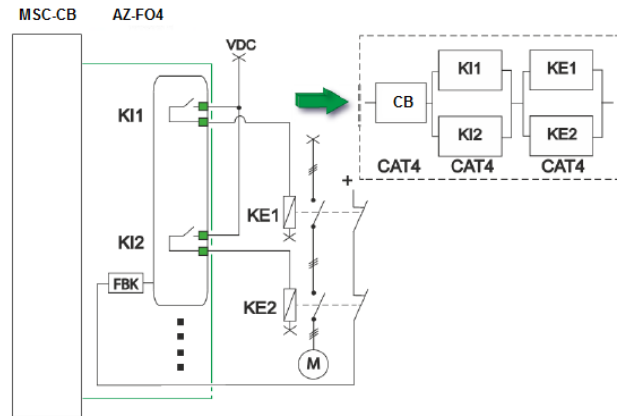

Figure 82: Examples of use

Manual Reset: If selected, a reset can be requested each time the IN input signal drops out. Otherwise, activation of the output follows the input conditions directly.

There are two types of reset: Manual and Monitored. On the selection of manual reset, only the signal transition from 0 to 1 is checked. With monitored reset, the double transition from 0 to 1 and then back to 0 is checked.

Enable Status: If activated, the current status of the relay outputs can be connected to a STATUS.

Enable external K reading: If activated, the switching times for external contactors can be read and checked:

- For category 1, it is not possible to enable the check of the external contactors.
- The check of the external contactors is always activated in category 4.

External K time monitoring: If selected, the delay is monitored. This option is unavailable for category 1 and obligatory for category 4.

External K delay (ms): Maximum delay that can be caused by the external contactors. Using this value, the maximum delay between the switching of the internal relays and the switching of the external contacts (on activation and deactivation) can be checked.

Enable Error Out: If activated, the ERROR_OUT output is enabled. **If an error is detected on the external FBK signal, the output changes to the logic level "High" (TRUE).**

The **Error OUT** signal is reset if one of the following events occurs:

1. The system is switched off and on again.
2. Activation of the RESET MSC-CB operator.

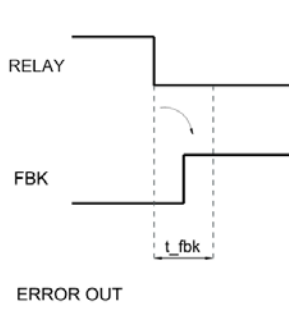

Figure 83: Example for RELAY with correct feedback signal: ERROR_OUT=FALSE in this case

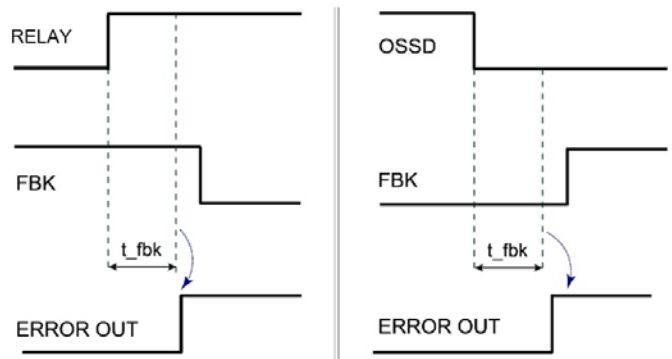

Figure 84: Example for RELAY with erroneous feedback signal (external switching time exceeded): ERROR_OUT=TRUE in this case

9.2.2. Input items

9.2.2.1. Emergency stop (E-STOP)

Using the E-STOP function block, the input status of an emergency stop device can be checked. If the emergency stop button is pressed, the OUTPUT output is “0” (FALSE), otherwise the OUTPUT output is “1” (TRUE).

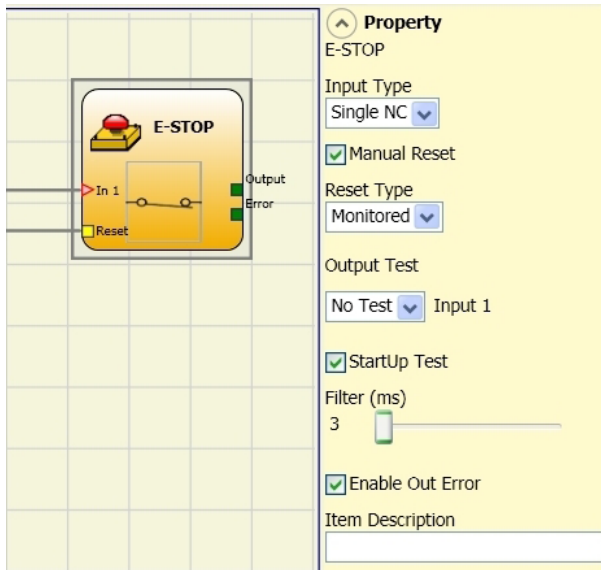

Figure 85: Emergency stop

Parameters

Input Type:

- › Single NC – makes it possible to connect emergency stop devices with one normally closed contact
- › Double NC – makes it possible to connect emergency stop devices with two normally closed contacts.

Manual Reset: If activated, a reset can be requested on every activation of the emergency stop. Otherwise, activation of the output will correspond directly to the input conditions.

There are two types of reset: “Manual” and “Monitored.” On the selection of manual reset, the system checks only the signal transition from 0 to 1. With monitored reset, the double transition from 0 to 1 and then back to 0 is checked.



Figure 86: Emergency stop manual/monitored reset

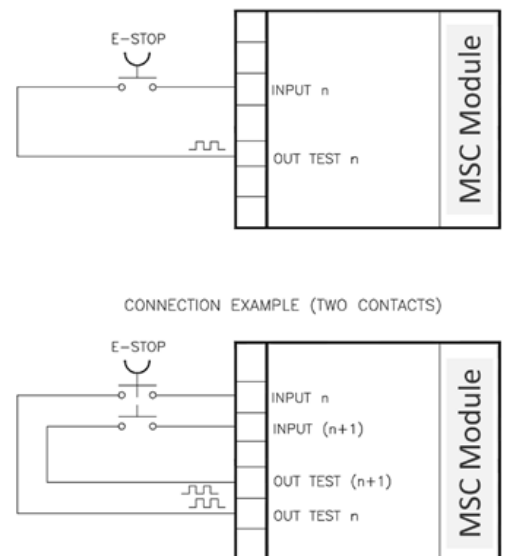

Figure 87: Connection example, emergency stop



Important!

If Manual Reset is selected, the next input must be used. Example: If Input1 and Input2 are used for the function block, Input3 must be used for the reset input.

Output Test: This option can be used to select which test output signals are to be sent to the emergency stop device. Short circuits between the cables can be detected and rectified by means of this additional check. For this purpose it is necessary to configure the test output signals (from the test output signals available).

StartUp Test: If activated, the test is performed on switching on the external component (emergency stop). This test is performed by pressing and releasing the emergency stop to carry out a complete function test and to activate the output. This test is requested only on starting the machine (on switching on the module).

Filter (ms): Makes it possible to filter the signals that are received from the emergency stop. This filter can be set to between 3 and 250 ms and removes any contact bouncing. The time set for the filter affects the calculation of the total response time of the module.

With Simultaneity: If activated, the simultaneous switching of the signals received from the emergency stop is checked.

Simultaneity (ms): This is active only if the previous parameter has been selected. Using this value you can define the maximum time (in ms) between the switching of the two signals that are received from the emergency stop.

Enable Out Error: If activated, an error detected by the function block is signaled.

Item Description: A functional description for the component can be entered here. This text is displayed in the upper part of the symbol.

9.2.2.2. Interlock (INTERLOCK)

The input status of a movable guard or a safety door is checked by the INTERLOCK function block. If the movable guard or the safety door is open, the OUTPUT output is "0" (FALSE), otherwise the OUTPUT output is "1" (TRUE).

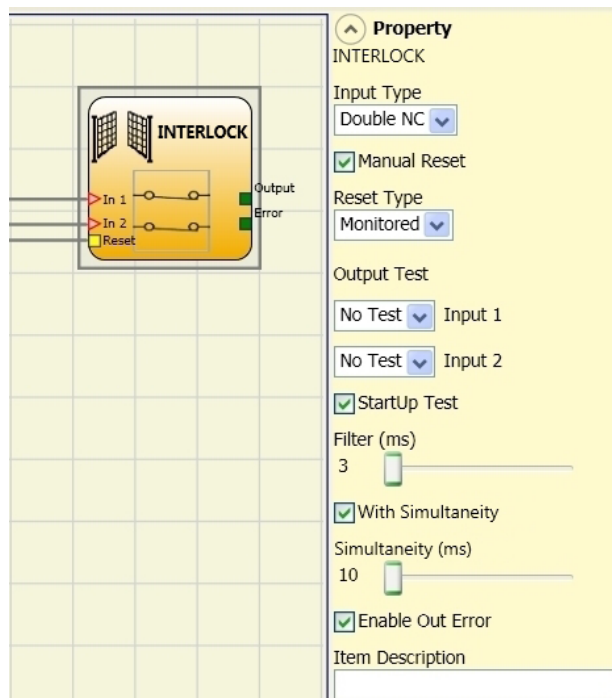

Figure 88: Interlock

Parameters

Input Type:

- › Double NC – makes it possible to connect components with two normally closed contacts.
- › Double NC/NO – makes it possible to connect components with one normally closed contact and one normally open contact.



Important!

- ➔ If input is inactive (OUTPUT output is “0” (FALSE)), connect as follows:
 - › NO contact on terminal that has been assigned to input IN1.
 - › NC contact on terminal that has been assigned to input IN2.

Manual Reset: If activated, a reset can be requested on every activation of the movable guard or the safety door. Otherwise, activation of the output will correspond directly to the input conditions.

There are two types of reset: “Manual” and “Monitored.” On the selection of manual reset, the system checks only the signal transition from 0 to 1. With monitored reset, the double transition from 0 to 1 and then back to 0 is checked.



Figure 89: Interlock manual/monitored reset

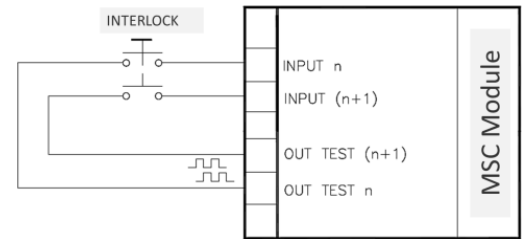

Figure 90: Connection example, interlock



Important!

If manual reset is selected, the next input after the inputs used by the function block must be used. Example: If Input1 and Input2 are used for the function block, Input3 must be used for the reset input.

Output Test: This option can be used to select which test output signals are to be sent to the component contacts. Short circuits between the cables can be detected and rectified by means of this additional check. For this purpose it is necessary to configure the test output signals (from the test output signals available).

StartUp Test: If activated, the test is performed on switching on the external component. This test is performed by opening the movable guard or the safety door to carry out a complete function test and to activate the output. This test is required only on starting the machine (switching on the module).

Filter (ms): This makes it possible to filter the signals that are received from the external contactors. The filter can be set to between 3 and 250 ms and removes any contact bouncing. The time set for the filter affects the calculation of the total response time of the module.

With Simultaneity: If activated, the simultaneous switching of the signals received from the external contacts is checked.

Simultaneity (ms): This is active only if the previous parameter has been selected. Using this value you can specify the maximum time (in ms) between the switching of the two different signals from the external contacts.

Enable Out Error: If activated, an error detected by the function block is signaled.

Item Description: A functional description for the component can be entered here. This text is displayed in the upper part of the symbol.

9.2.2.3. Single-channel interlock (SINGLE INTERLOCK)

The input status of a movable guard or a safety door is checked by the SINGLE INTERLOCK function block. If the movable guard or the safety door is open, the OUTPUT output is “0” (FALSE), otherwise the OUTPUT output is “1” (TRUE).

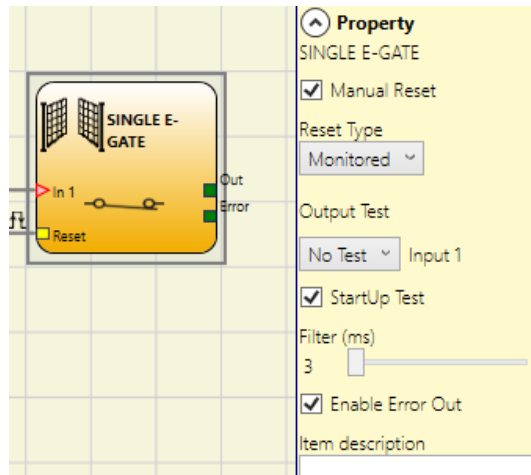

Figure 91: Single-channel interlock

Parameters

Manual Reset: If activated, a reset can be requested on every activation of the movable guard or the safety door. Otherwise the activation of the output will correspond to the input conditions.

There are two types of reset: “Manual” and “Monitored.” On the selection of manual reset, the system checks only the signal transition from 0 to 1. With monitored reset, the double transition from 0 to 1 and then back to 0 is checked.



Figure 92: Single-channel interlock manual/monitored reset



Important!

If manual reset is selected, the next input after the inputs used by the function block must be used. Example: If Input1 and Input2 are used for the function block, Input3 must be used for the reset input.

Output Test: This option can be used to select which test output signals are to be sent to the component contacts. Short circuits between the cables can be detected and rectified by means of this additional check. For this purpose it is necessary to configure the test output signals (from the test output signals available).

StartUp Test: If activated, the test is performed on switching on the external component. This test is performed by opening the movable guard or the safety door to carry out a complete function test and to activate the output. This test is required only on starting the machine (switching on the module).

Filter (ms): This makes it possible to filter the signals that are received from the external contactors. The filter can be set to between 3 and 250 ms and removes any contact bouncing. The time set for the filter affects the calculation of the total response time of the module.

Enable Error Out: If activated, an error detected by the function block is signaled.

Item Description: A functional description for the component can be entered here. This text is displayed in the upper part of the symbol.

9.2.2.4. Guard locking monitoring (LOCK FEEDBACK)

Using the LOCK FEEDBACK function block the state of the guard locking monitoring inputs for a movable guard or a safety door is checked. If the inputs signal that the guard locking is locked, the OUTPUT output is "0" (FALSE), otherwise the OUTPUT output is "1" (TRUE).

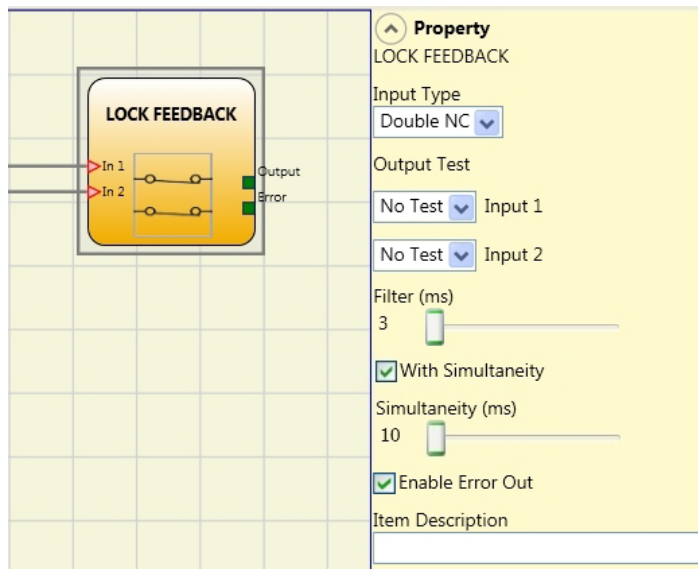

Figure 93: Guard lock monitoring

Parameters

Input Type:

- › Single NC – makes it possible to connect components with one normally closed contact.
- › Double NC – makes it possible to connect components with two normally closed contacts.
- › Dual-channel NC/NO – makes it possible to connect components with one normally closed contact and one normally open contact.



Important!

- ➔ If input is inactive (guard locking unlocked, OUTPUT output is "0" (FALSE)), connect as follows:
 - › NO contact on terminal that has been assigned to input IN1.
 - › NC contact on terminal that has been assigned to input IN2.

Output Test: This option can be used to select which test output signals are to be sent to the component contacts. Short circuits between the cables can be detected and rectified by means of this additional check. For this purpose it is necessary to configure the test output signals (from the test output signals available).

Filter (ms): This makes it possible to filter the signals that are received from the external contacts. This filter can be set to between 3 and 250 ms and removes any contact bouncing. The time set for the filter affects the calculation of the total response time of the module.

With Simultaneity: If activated, the simultaneous switching of the signals received from the external contacts is checked.

Simultaneity (ms): This is active only if the previous parameter has been selected. Using this value you can define the maximum time (in ms) between the switching of the two different signals received from the external contacts.

Enable Error Out: If activated, an error detected by the function block is signaled.

Item Description: A functional description for the component can be entered here. This text is displayed in the upper part of the symbol.

9.2.2.5. Key-operated rotary switch (KEY LOCK SWITCH)

Using the KEY LOCK SWITCH function block, the input status of a manual key-operated rotary switch is checked. If the key is not turned, the OUTPUT output is “0” (FALSE), otherwise the OUTPUT output is “1” (TRUE).

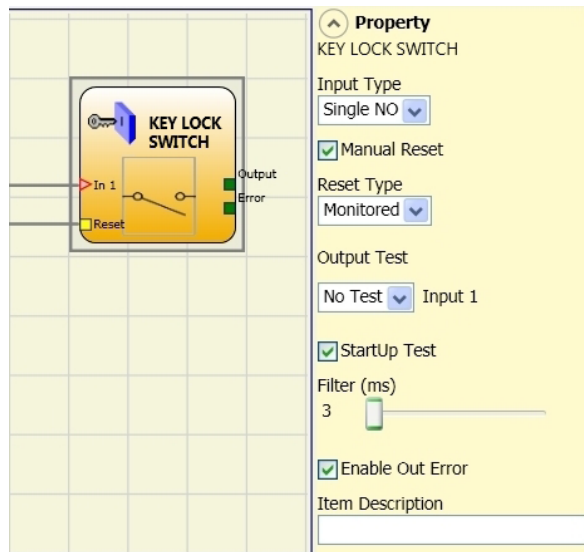

Figure 94: Key-operated rotary switch

Parameters

- › Single NO – makes it possible to connect components with one normally open contact
- › Double NO – makes it possible to connect components with two normally open contacts.

Manual Reset: If activated, a reset can be requested on every activation of the command. Otherwise, activation of the output will correspond directly to the input conditions.

There are two types of reset: “Manual” and “Monitored.” On the selection of manual reset, the system checks only the signal transition from 0 to 1. With monitored reset, the double transition from 0 to 1 and then back to 0 is checked.

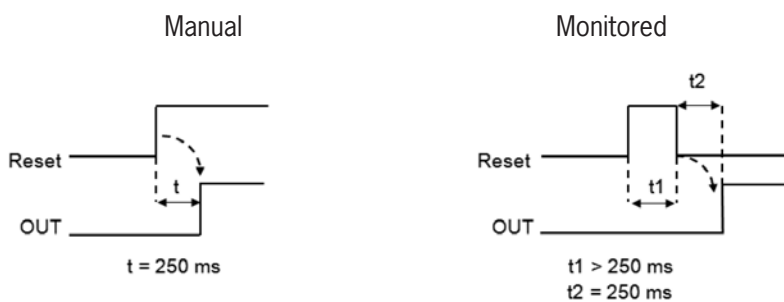

Figure 95: Key-operated rotary switch manual/monitored reset

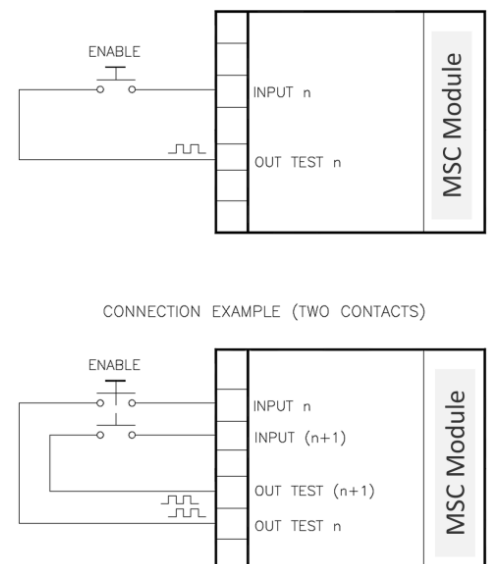

Figure 96: Connection examples, key-operated rotary switch



Important!

If manual reset is selected, the next input after the inputs used by the function block must be used. Example: If Input1 and Input2 are used for the function block, Input3 must be used for the reset input.

Output Test: This option can be used to select which test output signals are to be sent to the component contacts. Short circuits between the cables can be detected and rectified by means of this additional check. For this purpose it is necessary to configure the test output signals (from the test output signals available).

StartUp Test: If activated, the test is performed on switching on the external component. This test is performed by opening and activating the key-operated rotary switch to carry out a complete function test and to activate the OUTPUT output. This test is required only on starting the machine (on switching on the module).

Filter (ms): This makes it possible to filter the signals that are received from the external contactors. This filter can be set to between 3 and 250 ms and removes any contact bouncing. The time set for the filter affects the calculation of the total response time of the module.

With Simultaneity: If activated, the simultaneous switching of the signals received from the external contacts is checked.

Simultaneity (ms): This is active only if the previous parameter has been selected. Using this value you can specify the maximum time (in ms) between the switching of the two different signals received from the external contacts.

Enable Out Error: If activated, an error detected by the function block is signaled.

Item Description: A functional description for the component can be entered here. This text is displayed in the upper part of the symbol.

9.2.2.6. Optoelectronic safety light grid or safety laser scanner (ESPE)

Using the ESPE function block the input status of an optoelectronic safety light grid (or safety light scanner) is checked. If the area protected by the light curtain is interrupted (outputs on the light grid FALSE), the OUTPUT output is "0" (FALSE). Conversely, if this area is clear and the outputs are "1" (TRUE), the OUTPUT output is "1" (TRUE).

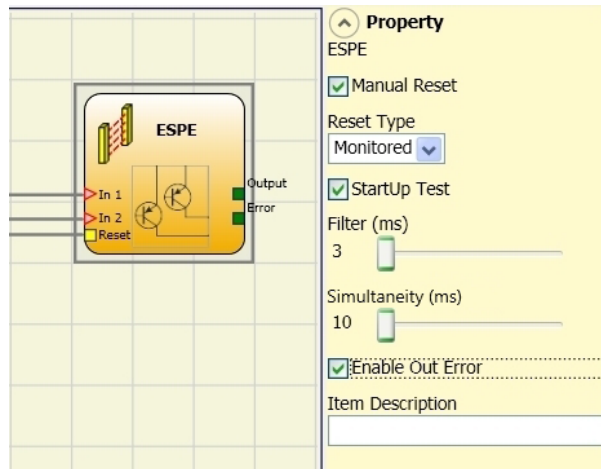

Figure 97: ESPE

Parameters

Manual Reset: If activated, a reset can be requested each time the area protected by the safety light grid is interrupted. Otherwise, activation of the output will correspond directly to the input conditions.

There are two types of reset: "Manual" and "Monitored." On the selection of manual reset, the system checks only the signal transition from 0 to 1. With monitored reset, the double transition from 0 to 1 and then back to 0 is checked.



Figure 98: ESPE manual/monitored reset

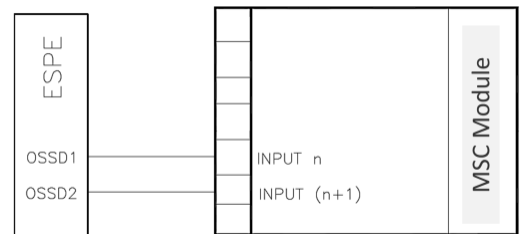

Figure 99: Connection example, ESPE



Important!

If manual reset is selected, the next input after the inputs used by the function block must be used. Example: If Input1 and Input2 are used for the function block, Input3 must be used for the reset input.

The OUT TEST signals cannot be used for the static safety output ESPE, as the test signals are generated by the ESPE.

StartUp Test: If activated, the test is performed on switching on the safety light grid. This test is performed by occupying and clearing the area protected by the safety light grid to carry out a complete function test and to activate the output. This test is required only on starting the machine (on switching on the module).

Filter (ms): Makes it possible to filter the signals that are received from the safety light grid. This filter can be set to between 3 and 250 ms and removes any contact bounce. The time set for the filter affects the calculation of the total response time of the module.

With Simultaneity: If selected, the simultaneous switching of the signals received from the safety light grid is checked.

Simultaneity (ms): This is active only if the previous parameter has been selected. Using this value you can define the maximum permissible time (in ms) between the switching of the two different signals received from the safety light grid.

Enable Out Error: If activated, an error detected by the function block is displayed.

Item Description: A functional description for the component can be entered here. This text is displayed in the upper part of the symbol.

9.2.2.7. Safety footswitch (FOOTSWITCH)

Using the FOOTSWITCH function block the input status of a safety footswitch is checked. If the footswitch is not pressed, the OUTPUT output is "0" (FALSE), otherwise the OUTPUT output is "1" (TRUE).

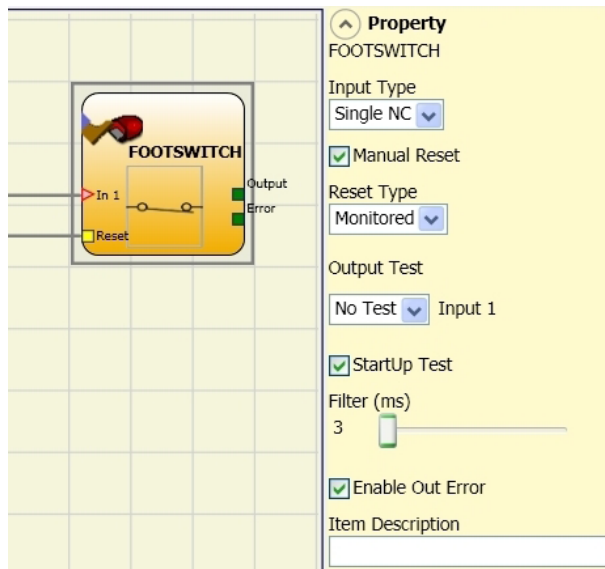

Figure 100: Safety footswitch

Parameters

Input Type:

- › Single NC – makes it possible to connect components with one normally closed contact.
- › Single NO – makes it possible to connect footswitches with one normally open contact.
- › Double NC – makes it possible to connect footswitches with two normally closed contacts.
- › Dual-channel NC/NO – makes it possible to connect footswitches with one normally closed contact and one normally open contact.



Important!

- ➔ If input is inactive (OUTPUT output is "0" (FALSE)), connect as follows:
 - › NO contact on terminal that has been assigned to input IN1.
 - › NC contact on terminal that has been assigned to input IN2.

Manual Reset: If activated, a reset can be requested on every activation of the safety footswitch. Otherwise, activation of the output will correspond directly to the input conditions.

There are two types of reset: "Manual" and "Monitored." On the selection of manual reset, the system checks only the signal transition from 0 to 1. With monitored reset, the double transition from 0 to 1 and then back to 0 is checked.



Figure 101: Safety footswitch manual/monitored reset

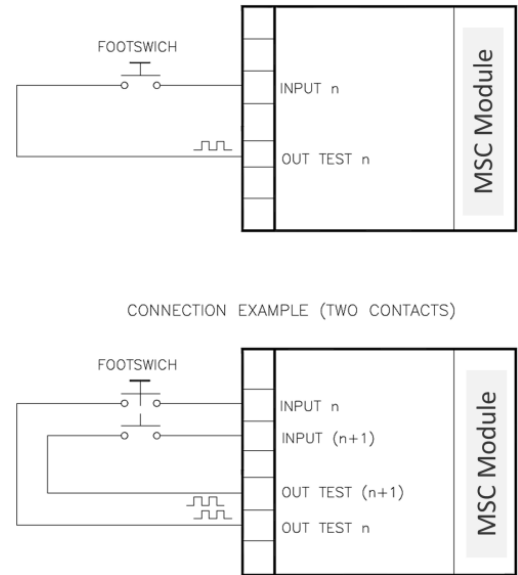

Figure 102: Connection examples, safety footswitch



Important!

If manual reset is selected, the next input after the inputs used by the function block must be used. Example: If Input1 and Input2 are used for the function block, Input3 must be used for the reset input.

Output Test: This option can be used to select which test output signals are to be sent to the component contacts. Short circuits between the cables can be detected and rectified by means of this additional check. For this purpose it is necessary to configure the test output signals (from the test output signals available).

StartUp Test: If activated, the test is performed on switching on the external component. This test is performed by pressing and releasing the footswitch to carry out a complete function test and to activate the output. This test is required only on starting the machine (on switching on the module).

Filter (ms): This makes it possible to filter the signals that are received from the external contactors. This filter can be set to between 3 and 250 ms and removes any contact bounce. The time set for the filter affects the calculation of the total response time of the module.

With Simultaneity: If activated, the simultaneous switching of the signals received from the external contacts is checked.

Simultaneity (ms): This is active only if the previous parameter has been selected. Using this value you can specify the maximum time (in ms) between the switching of the two different signals from the external contacts.

Enable Out Error: If activated, an error detected by the function block is displayed.

Item Description: A functional description for the component can be entered here. This text is displayed in the upper part of the symbol.

9.2.2.8. Operating mode selection (MOD-SEL)

Using the MOD-SEL function block the input status of an operating mode selector switch (up to 4 inputs) is checked. If only one of the IN inputs is "1" (TRUE), the corresponding OUTPUT output is also "1" (TRUE). In all other cases, i.e. if all IN inputs are "0" (FALSE) or more than one IN input is "1" (TRUE), all OUTPUT outputs are "0" (FALSE).

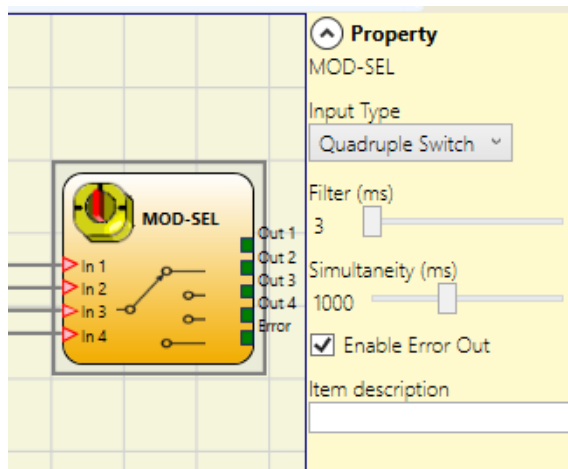

Figure 103: MOD-SEL

Parameters

Input Type:

- › Double Switch – makes it possible to connect operating mode selector switches with two switch positions.
- › Triple Switch – makes it possible to connect operating mode selector switches with three switch positions.
- › Quadruple Switch – makes it possible to connect operating mode selector switches with four switch positions.

Filter (ms): Makes it possible to filter the signals that are received from the operating mode selector switch. This filter can be set to between 3 and 250 ms and removes any contact bouncing. The time set for the filter affects the calculation of the total response time of the module.

Simultaneity (ms): Is always selected. Defines the maximum permissible time (ms) between the switching of the different signals received from the external contacts of the device.

Enable Error Out: If activated, an error detected by the function block is displayed.

Item Description: A functional description for the component can be entered here. This text is displayed in the upper part of the symbol.

9.2.2.9. Light barrier (PHOTOCELL)

Using the PHOTOCELL function block the input status of an optoelectronic safety light barrier is checked.

If the beam from the light barrier is obscured (output on the light barrier FALSE), the OUTPUT output is "0" (FALSE). If, conversely, the beam is not obscured (output on the light barrier TRUE), the OUTPUT output is "1" (TRUE).

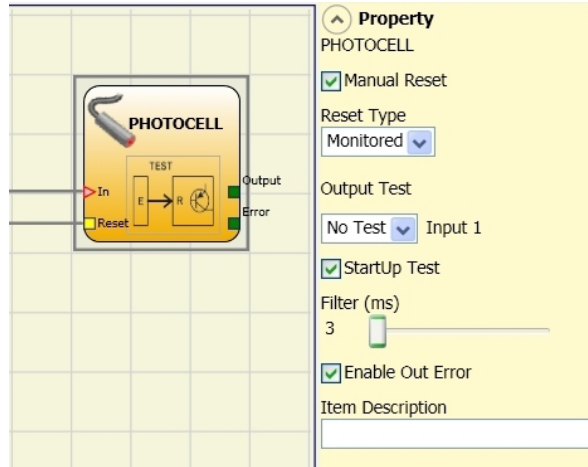

Figure 104: Light barrier

Parameters

Manual Reset: If activated, a reset can be requested on every activation of the safety light barrier. Otherwise, activation of the output will correspond directly to the input conditions.

There are two types of reset: "Manual" and "Monitored." On the selection of manual reset, the system checks only the signal transition from 0 to 1. With monitored reset, the double transition from 0 to 1 and then back to 0 is checked.



Figure 105: Light barrier manual/monitored reset

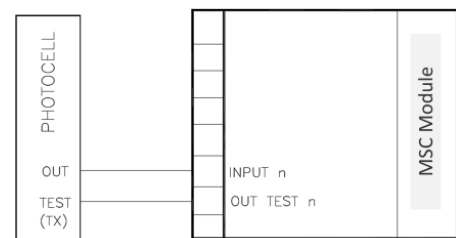

Figure 106: Connection example, light barrier



Important!

- › A test output is obligatory and can be selected using one of the 4 possible OUT_TEST outputs.
- › Attention: If RESET is selected, the next input must be used for the reset. Example: If INPUT1 is used for the function block, INPUT2 must be used for the RESET.
- › The reaction time of the light barrier must be > 2 ms and < 20 ms.

Output Test: This option can be used to select which test output signals are to be sent to the test input on the light barrier.

Short circuits between the cables can be detected and rectified by means of this additional check. For this purpose it is necessary to configure the test output signals (from the test output signals available).

StartUp Test: If activated, the test is performed on switching on the external component. This test is performed by covering and clearing the safety light barrier to carry out a complete function test and to activate the output. This test is required only on starting the machine (on switching on the module).

Filter (ms): This makes it possible to filter the signals that are received from the external contactors. This filter can be set to between 3 and 250 ms and removes any contact bouncing. The time set for the filter affects the calculation of the total response time of the module.

Enable Out Error: If activated, an error detected by the function block is displayed.

Item Description: A functional description for the component can be entered here. This text is displayed in the upper part of the symbol.

9.2.2.10. Two-hand control (TWO-HAND)

Using the TWO-HAND function block the input status of a two-hand control switch is checked.

If both pushbuttons are pressed at the same time (within max. 500 ms), the OUTPUT output is "1" (TRUE); this status is retained until the pushbuttons are released. Otherwise, the OUTPUT output is "0" (FALSE).

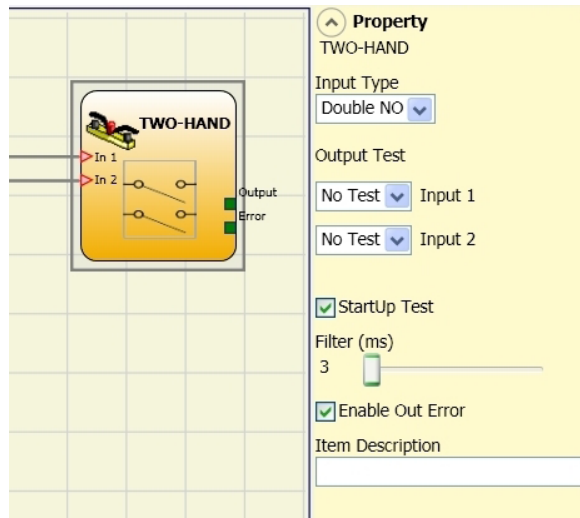

Figure 107: Two-hand control

Parameters

Input Type:

- › Double NO – makes it possible to connect a two-hand switch with a normally open contact for each pushbutton (EN 574 III A).
- › Quad NC/NO – makes it possible to connect a two-hand switch with a dual-channel normally closed/normally open contact for each pushbutton (EN 574 III C).



Important!

- ➔ If input is inactive (OUTPUT output is "0" (FALSE)), connect as follows:
 - › NO contact on terminal that has been assigned to input IN1.
 - › NC contact on terminal that has been assigned to input IN2.

Output Test: This option can be used to select which test output signals are to be sent to the component contacts. Short circuits between the cables can be detected and rectified by means of this additional check. For this purpose it is necessary to select the test output signals.

StartUp Test: If activated, the test is performed on switching on the external component (two-hand control). This test is performed by pressing at the same time (within max. 500 ms) and releasing both pushbuttons to carry out a complete function test and to activate the output. This test is required only on starting the machine (on switching on the module).

Filter (ms): Makes it possible to filter the input signals. This filter can be set to between 3 and 250 ms and removes any contact bouncing. The time set for the filter affects the calculation of the total response time of the module.

Enable Out Error: If activated, an error detected by the function block is displayed.

Item Description: A functional description for the component can be entered here. This text is displayed in the upper part of the symbol.

9.2.2.11. NETWORK_IN

This function block establishes the input interface of a network connection by producing a “1” (TRUE) in the OUTPUT output when the logic level is “High” – otherwise “0” (FALSE) will be set.

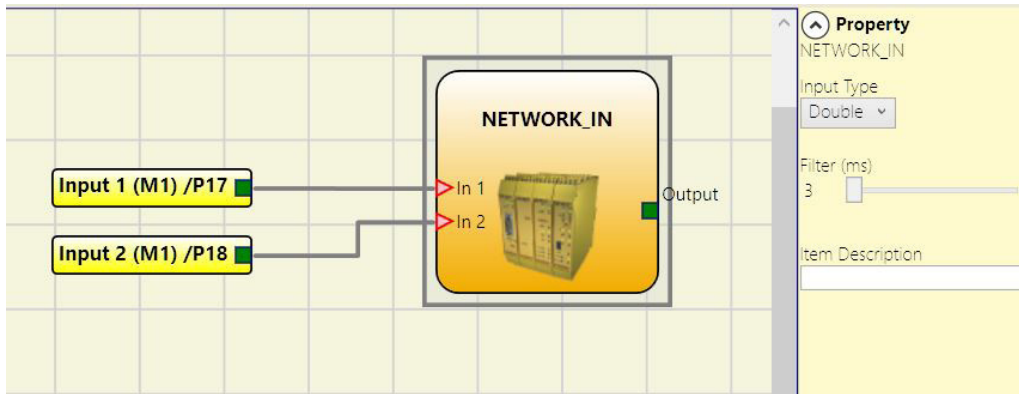

Figure 108: NETWORK_IN

Parameters

Input Type:

- › Single – makes it possible to connect the signal outputs from another MSC-CB base unit.
- › Double – makes it possible to connect the OSSD outputs from another MSC-CB base unit.

Filter (ms): Makes it possible to filter the signals that are received from another MSC-CB base unit.

This filter can be set to between 3 and 250 ms. The time set for the filter affects the calculation of the total response time of the module.



Important!

- ➔ This input can be assigned only to the base unit MSC-CB.
- ➔ It must be used if the **OSSD** outputs on an MSC system are connected to the inputs on a downstream MSC system or together with the NETWORK operator.

9.2.2.12. SENSOR

Using the SENSOR function block the input status of a sensor (not a safety sensor) is checked. If the beam from the sensor is obscured (output on the light barrier FALSE), the OUTPUT output is "0" (FALSE). Conversely, if this beam is not occupied and the output on the sensor is "1" (TRUE), the OUTPUT output is "1" (TRUE).

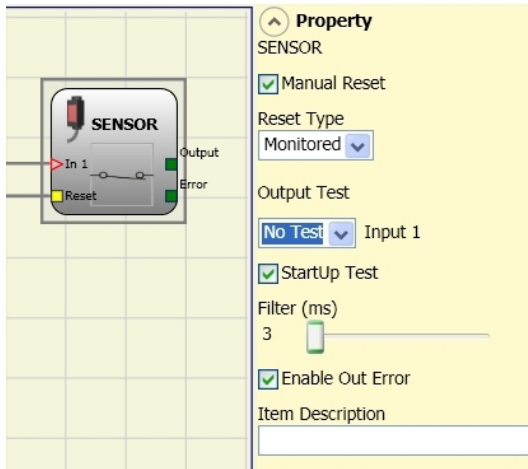

Figure 109: Sensor

Parameters

Manual Reset: If activated, a reset can be requested each time the area protected by the sensor is occupied. Otherwise, activation of the output will correspond directly to the input conditions.

There are two types of reset: "Manual" and "Monitored." On the selection of manual reset, the system checks only the signal transition from 0 to 1. With monitored reset, the double transition from 0 to 1 and then back to 0 is checked.



Important!

If manual reset is selected, the next input after the inputs used by the function block must be used. Example: If Input1 is used for the function block, Input2 must be used for the reset input.

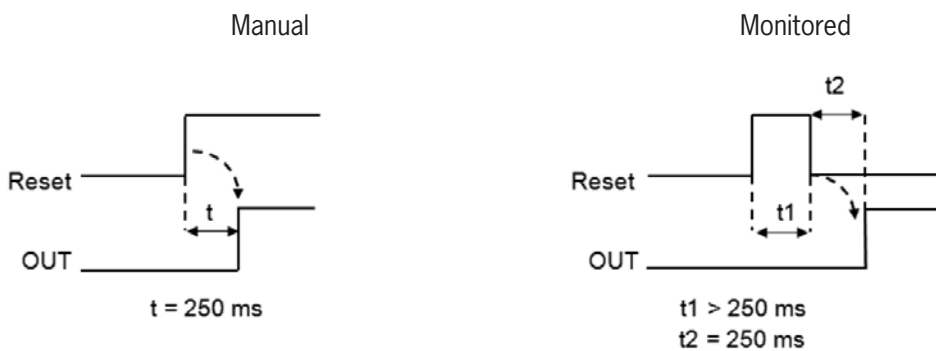

Figure 110: Sensor manual/monitored reset

Output Test: This option can be used to select which test output signals are to be sent to the sensor. Short circuits between the cables can be detected and rectified by means of this additional check. For this purpose it is necessary to configure the test output signals (from the test output signals available).

StartUp Test: If activated, the test is performed on switching on the sensor. This test is performed by occupying and clearing the area protected by the sensor to carry out a complete function test and to activate the OUTPUT output. This test is required only on starting the machine (on switching on the module).

Filter (ms): This makes it possible to filter the signals that are received from the sensor. This filter can be set to between 3 and 250 ms and removes any contact bouncing. The time set for the filter affects the calculation of the total response time of the module.

Enable Out Error: If activated, an error detected by the function block is displayed.

Item Description: A functional description for the component can be entered here. This text is displayed in the upper part of the symbol.

9.2.2.13. Pressure sensitive mat (S-MAT)

Using the pressure sensitive mat function block the input status of a pressure sensitive mat is checked. If there is a person on the footmat, the OUTPUT output is "0" (FALSE), otherwise, i.e. if the footmat is clear, the OUTPUT output is "1" (TRUE).

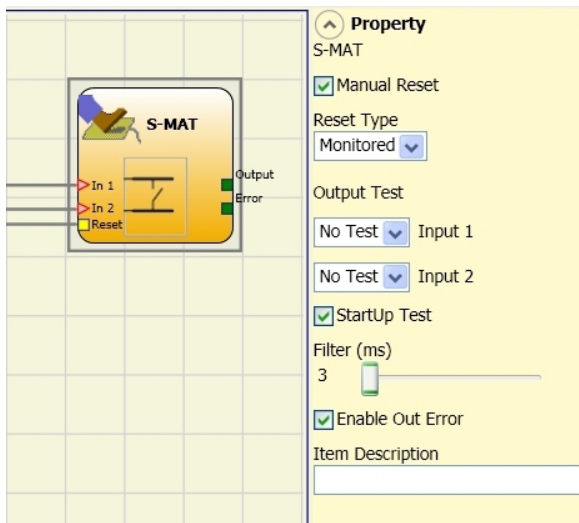

Figure 111: Pressure sensitive mat

Parameters

Manual Reset: If activated, a reset can be requested on every activation of the pressure sensitive mat. Otherwise, activation of the output follows the input conditions directly.

There are two types of reset: "Manual" and "Monitored." On the selection of manual reset, the system checks only the signal transition from 0 to 1. With monitored reset, the double transition from 0 to 1 and then back to 0 is checked.



Important!

- ➔ If manual reset is selected, the next input after the inputs used by the function block must be used. Example: If Input1 and Input2 are used for the function block, Input3 must be used for the reset input.
- ➔ The use of two test outputs is obligatory. Each OUT TEST output be connected to only one pressure sensitive mat input (it is not allowed to connect two inputs in parallel).
- ➔ The pressure sensitive mat function block cannot be used for two-wire components or terminating resistors.



Figure 112: Pressure sensitive mat manual/monitored reset

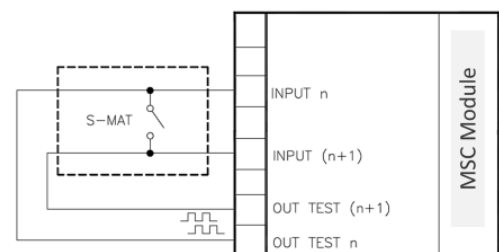

Figure 113: Connection example, pressure sensitive mat

Output Test: This option can be used to select which test output signals are to be sent to the pressure sensitive mat contacts. Short circuits between the wires can be detected and rectified by means of this check. For this purpose it is necessary to configure the test output signals (from the test output signals available). The test signals are obligatory.

StartUp Test: If activated, the test is performed on switching on the external component. This test is performed by standing on and clearing the pressure sensitive mat to carry out a complete function test and to activate the output. This test is requested only on starting the machine (on switching on the module).

Filter (ms): This makes it possible to filter the signals that are received from the external contactors. This filter can be set to between 3 and 250 ms and removes any contact bouncing. The time set for the filter affects the calculation of the total response time of the module.

Enable Out Error: If activated, an error detected by the function block is displayed.

Item Description: A functional description for the component can be entered here. This text is displayed in the upper part of the symbol.

9.2.2.14. Switch (SWITCH)

Using the SWITCH function block the input status of a pushbutton or switch (NOT A SAFETY SWITCH) is checked. If the pushbutton is pressed, the OUTPUT output is "1" (TRUE), otherwise the OUTPUT output is "0" (FALSE).

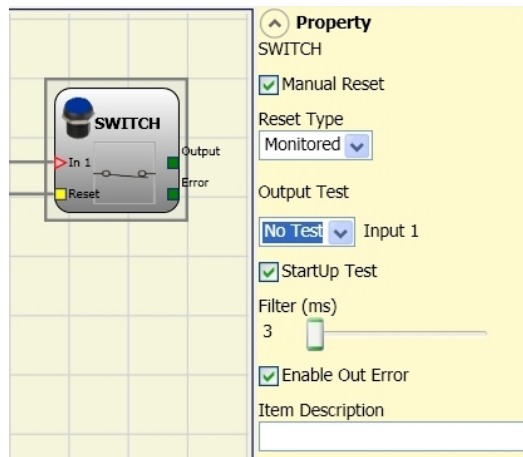

Figure 114: Switch

Parameters

Manual Reset: If activated, a reset can be requested on every activation of the device. Otherwise, activation of the output will correspond directly to the input conditions.

There are two types of reset: "Manual" and "Monitored." On the selection of manual reset, the system checks only the signal transition from 0 to 1. With monitored reset, the double transition from 0 to 1 and then back to 0 is checked.



Figure 115: Switch manual/monitored reset



Important!

If manual reset is selected, the next input after the inputs used by the function block must be used. Example: If Input1 is used for the function block, Input2 must be used for the reset input.

Output Test: This option can be used to select which test output signals are to be sent to the switch. Short circuits between the cables can be detected and rectified by means of this additional check. For this purpose it is necessary to configure the test output signals (from the test output signals available).

StartUp Test: If activated, the test is performed on switching on the switch. This test is performed by closing and opening the switch contact to carry out a complete function test and to activate the output. This test is required only on starting the machine (on switching on the module).

Filter (ms): Makes it possible to filter the signals that are received from the switch. This filter can be set to between 3 and 250 ms and removes any contact bouncing. The time set for the filter affects the calculation of the total response time of the module.

Enable Out Error: If activated, an error detected by the function block is displayed.

Item Description: A functional description for the component can be entered here. This text is displayed in the upper part of the symbol.

9.2.2.15. Enabling switch (ENABLING SWITCH)

Using the ENABLING SWITCH function block the input status of a 3-stage enabling switch is checked. If this switch is not pressed (position 1) or is fully pressed (position 3), the OUTPUT output is "0" (FALSE). In the middle position (position 2), the OUTPUT output is "1" (TRUE); see truth tables *Page 119*.

➔ For the ENABLING SWITCH function block, the module assigned must have the firmware version as shown in the table below, as a minimum:

MSC-CB	F18FO2	F18	F116	FM4
1.0	0.4	0.4	0.4	0.0

Table 67: Firmware versions required

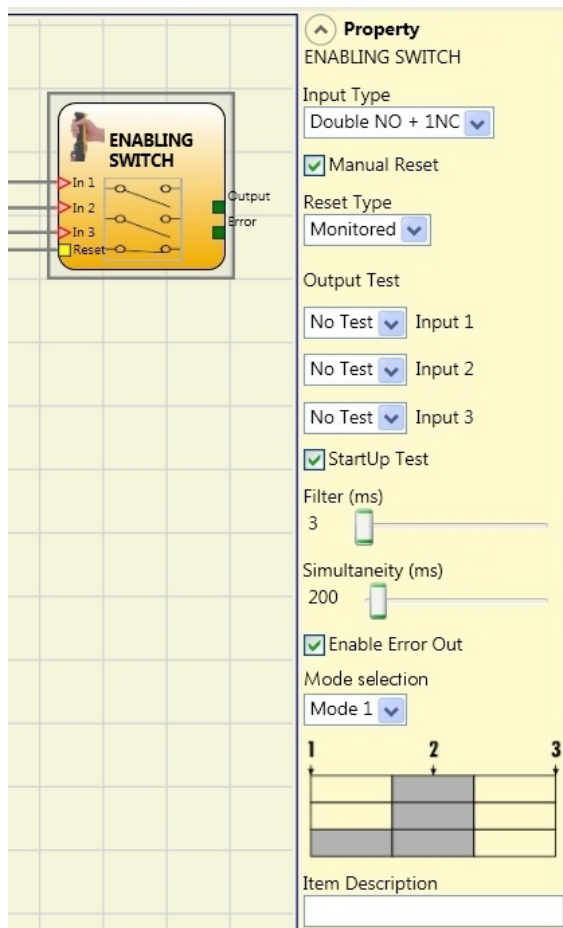

Figure 116: Enabling switch

Parameters

Input Type:

- › Double NO – makes it possible to connect an enabling switch with two normally open contacts.
- › Double NO + 1NC – makes it possible to connect an enabling switch with two normally open contacts and one normally closed contact.

Output Test: Makes it possible to select the test output signals that are to be sent to the enabling switch. Short circuits between the cables can be detected and rectified by means of this additional check. For this purpose it is necessary to configure the test output signals (from the test output signals available).

StartUp Test: If activated, the test is performed on switching on the external component (enabling switch). This test is performed by pressing and releasing the switch to carry out a complete function test and to activate the output. This test is required only on starting the machine (switching on the module).

Simultaneity (ms): Is always selected. Defines the maximum permissible time (ms) between the switching of the different signals received from the external contacts of the device.

Filter (ms): This parameter makes it possible to filter the signals from the device control system. This filter can be set to between 3 and 250 ms and removes any contact bouncing. The time set for the filter affects the calculation of the total response time of the module.

Selection mode: Either of two modes can be selected if dual-channel NO + 1 NC is selected

Mode 1 (device with 2 NO + 1 NC)

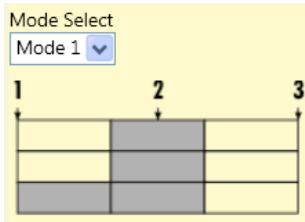

POSITION 1: Enabling switch fully released

POSITION 2: Enabling switch pressed to center position

POSITION 3: Enabling switch pressed all the way down

Input	Position		
	1	2	3
IN1	0	1	0
IN2	0	1	0
IN3	1	1	0
OUT	0	1	0

Table 68: Only with 2 normally open contacts + 1 normally closed contact

Mode 2 (device with 2 NO + 1 NC)

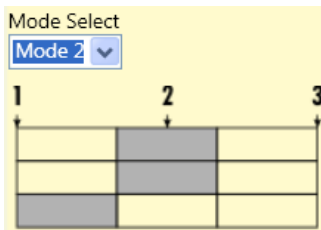

POSITION 1: Enabling switch fully released

POSITION 2: Enabling switch pressed to center position

POSITION 3: Enabling switch pressed all the way down

Input	Position		
	1	2	3
IN1	0	1	0
IN2	0	1	0
IN3	1	0	0
OUT	0	1	0

Table 69: Only with 2NO + 1NC

Enable Error Out: If activated, an error detected by the function block is displayed.

Item Description: A functional description for the component can be entered here. This text is displayed in the upper part of the symbol.

9.2.2.16. Testable safety device (TESTABLE SAFETY DEVICE)

Using the TESTABLE SAFETY DEVICE function block the input status of a single-channel or a dual-channel safety sensor (both normally closed contacts and normally open contacts) is checked. Refer to the following tables for the sensor type and behavior:

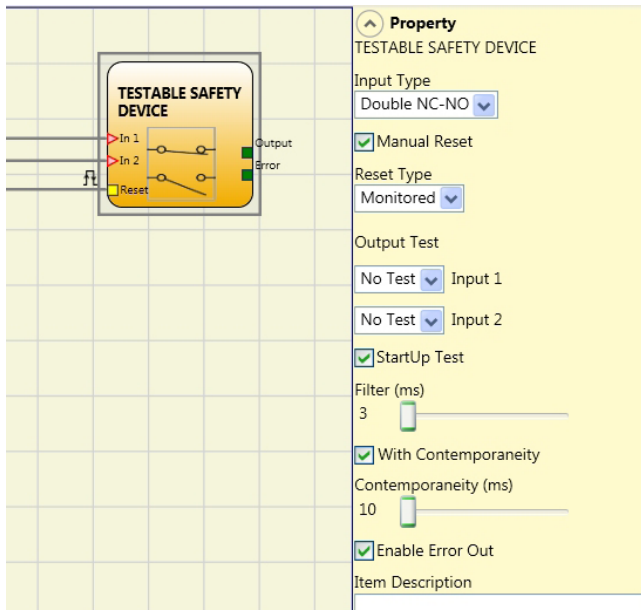

Figure 117: Testable safety device

Single normally closed contact

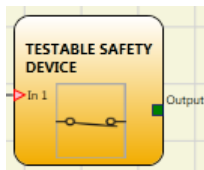

Figure 118: NC

IN	OUT
0	0
1	1

Table 70: Status table NC

Single normally open contact

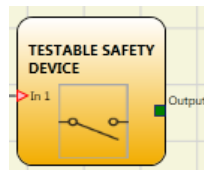

Figure 119: NO

IN	OUT
0	0
1	1

Table 71: Status table NO

Double NC

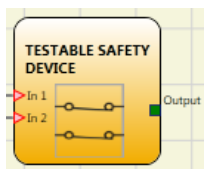

Figure 120: Dual-channel NC

IN1	IN2	OUT	Simultaneity error *
0	0	0	-
0	1	0	X
1	0	0	X
1	1	1	X

Table 72: Status table dual-channel NC

Dual-channel NC-NO

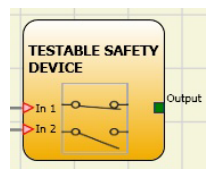

Figure 121: Dual-channel NC-NO

IN1	IN2	OUT	Simultaneity error *
0	0	0	X
0	1	0	-
1	0	1	-
1	1	0	X

Table 73: Status table, dual-channel NC-NO

* Simultaneity error = max. time between the switching of the individual contacts has been exceeded.

Parameters

Manual Reset: If activated, a reset can be requested on every activation of the device. Otherwise, activation of the output will correspond directly to the input conditions. There are two types of reset: "Manual" and "Monitored." On the selection of manual reset, the system checks only the signal transition from 0 to 1. With monitored reset, the double transition from 0 to 1 and then back to 0 is checked.



Important!

If manual reset is selected, the next input after the inputs used by the function block must be used. Example: If Input1 and Input2 are used for the function block, Input3 must be used for the reset input.

Output Test: This option can be used to select which test output signals are to be sent to the component contacts. Short circuits between the cables can be detected and rectified by means of this additional check. For this purpose it is necessary to configure the test output signals (from the test output signals available).

StartUp Test: If activated, the test is performed on switching on the device. This test requires the activation and deactivation of the device to carry out a complete function test and to activate the output. This test is required only on starting the machine (on switching on the module).

Filter (ms): Makes it possible to filter the signals that are received from the device. This filter can be set to between 3 and 250 ms and removes any contact bouncing. The time set for the filter affects the calculation of the total response time of the module.

With Contemporaneity: If selected, the check for simultaneous switching of the signals received from the device is enabled.

Contemporaneity (ms): This is active only if the previous parameter has been selected. Defines the maximum permissible time (in ms) between the switching of the two different signals received from the sensor.

Enable Error Out: If activated, an error detected by the function block is displayed.

Item Description: A functional description for the component can be entered here. This text is displayed in the upper part of the symbol.

9.2.2.17. Semiconductor output (SOLID STATE DEVICE)

Using the semiconductor output function block the input status is checked. If 24 VDC is present on the inputs, the OUTPUT output switches to "1" (TRUE), otherwise the OUTPUT output is "0" (FALSE).

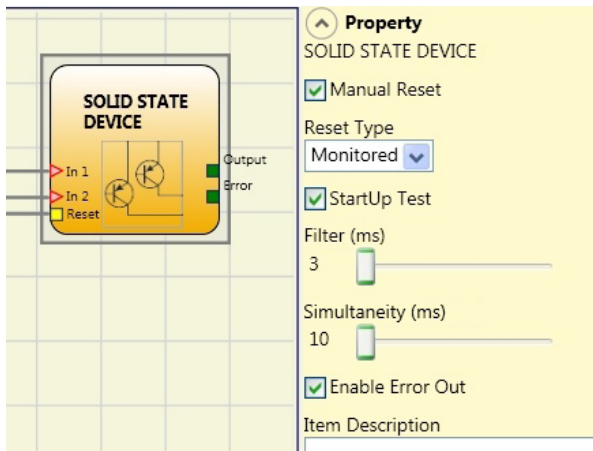

Figure 122: Semiconductor output

Parameters

Manual Reset: If activated, a reset can be requested on every activation of the safety function. Otherwise, activation of the output follows the input conditions directly.

There are two types of reset: "Manual" and "Monitored." On the selection of manual reset, the system checks only the signal transition from 0 to 1. With monitored reset, the double transition from 0 to 1 and then back to 0 is checked.



Figure 123: Semiconductor output manual/monitored reset



Important!

If manual reset is selected, the next input after the inputs used by the function block must be used. Example: If Input1 and Input2 are used for the function block, Input3 must be used for the reset input.

StartUp Test: If activated, the test is performed on switching on the safety system. This test requires the activation and deactivation of the device to carry out a complete function test and to activate the output. This test is required only on starting the machine (on switching on the module).

Filter (ms): Makes it possible to filter the signals from the safety device. This filter can be set to between 3 and 250 ms and removes any contact bouncing. The time set for the filter affects the calculation of the total response time of the module.

Simultaneity (ms): Is always selected. Defines the maximum permissible time (in ms) between the switching of the two different signals received from the device.

Enable Error Out: If activated, an error detected by the function block is displayed.

Item Description: A functional description for the component can be entered here. This text is displayed in the upper part of the symbol.

9.2.2.18. Fieldbus input (FIELDBUS INPUT)

A conventional input can be provided using this element; the status of the input can be changed via the fieldbus.

The respective bit must be selected to perform changes on the input. The following table shows the max. number of virtual inputs.

Base unit	Fieldbus module firmware	Number of virtual inputs
MSC-CB-S	≥ 2.0	Max. 32
MSC-CB-S	< 2.0	Max. 8
MSC-CB	Independent	Max. 8

Table 74: Max. number of sensors at the fieldbus input

The states are depicted on the fieldbus using four bytes. (You will find more detailed information in the fieldbus manual on the CD ROM "EUCHNER Safety Designer.")

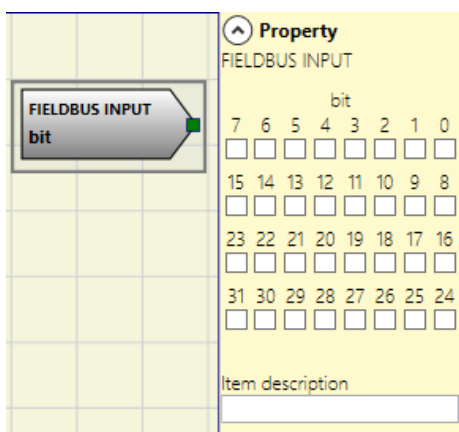

Figure 124: Fieldbus input



DANGER

The fieldbus input is **not** a safety input.

9.2.2.19. LL0 – LL1

A logic level can be supplied to the input of a component using these elements.

LL0 → Logic level 0

LL1 → Logic level 1



Figure 125: Logic level



Important!

LL0 and LL1 cannot be used to deactivate the logic connections in the program.

9.2.2.20. Comments

You can enter a description and position it at any point in the diagram using this option.



Figure 126: Comments

9.2.2.21. Title

Automatically adds the name of the manufacturer, the system planner, the project name and the checksum (CRC).

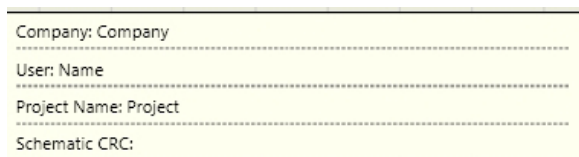

Figure 127: Title

9.3. Function blocks for speed control



Important!

- An external error or a malfunction on the encoder/proximity switch or on its connections does not necessarily result in a change in the safety status on the normal output of the function block (e.g. “zero”). Faults or malfunctions on the encoder/proximity switch or in the cabling are, however, detected by the module and managed and specified via the diagnostics bit (error output (Error)) that can be activated on each function block.
- To ensure safety, the diagnostics bit must be used in the configuration program to initiate possible deactivation of the outputs if the axis is in operation. If there are no external problems on the encoder/proximity switch, the “Error” output is 0 (zero).
- If there are the following external problems on the encoder/proximity switch, the “Error” output is 1 (one):
 - Encoder or proximity switch missing.
 - One or more connections on the encoder or proximity switch missing.
 - No encoder supply (only TTL model with external supply).
 - Frequency discrepancy between the signals on the encoder/proximity switch.
 - Phase error on the encoder signals or cycle error on an individual phase.

Property
STAND STILL

Axis type: Sensor Type:

Measuring device:

Pitch: [mm/revolution]

Proximity choice:

Measurement
Encoder Resolution (< 10000): [pulse/revolution]

Verification
Proximity Resolution (< 100): [pulse/revolution]

Gear Ratio: (1 to 100 step 0,1)

Hysteresis (%):

Zero speed limit (< 20): [m/min]

Frequency zero speed (>= 1Hz)

[Hz]	Measurement	Verification
$f_M =$	166,667	166,667
$f_m =$	165	165

Item Description:

Figure 128: Example for the speed regulation function block with “Error Out” activated

9.3.1. Speed monitoring (SPEED CONTROL)

The speed monitoring function block checks the speed of a device. If the measured speed exceeds a previously set limit, the OVER output switches to “0” (FALSE). If the speed is below the previously set limit, the OVER output is “1” (TRUE).

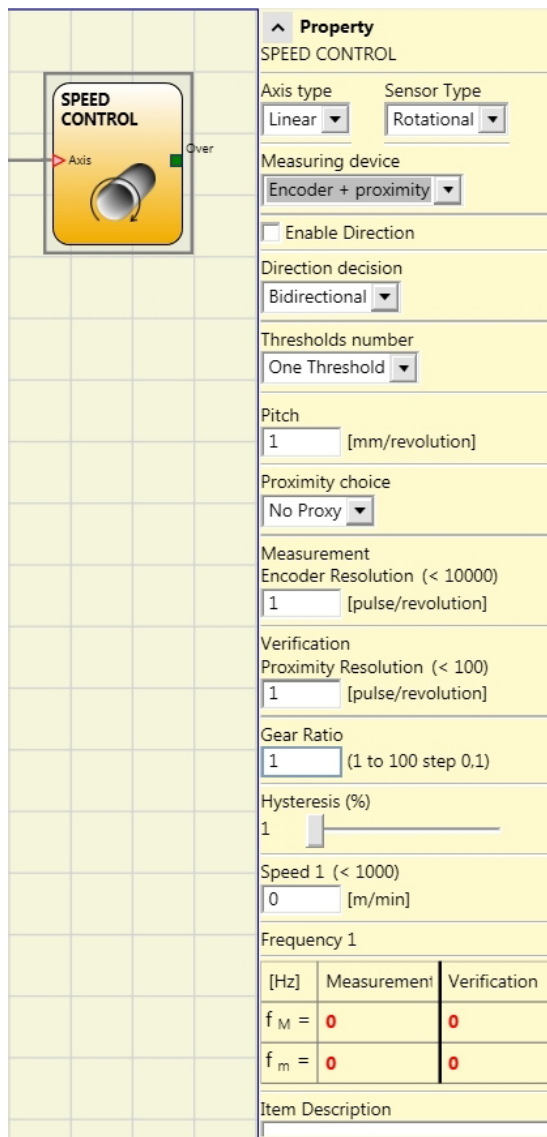

Figure 129: Speed monitoring

Parameters

Axis type: Defines the type of axis that is monitored by the device. “Linear” if the movement is linear or “Rotational” if the movement is rotary.

Sensor Type: If “Linear” is selected for the previous parameter, the sensor type connected to the inputs of the module is defined here. “Rotational” (e.g. encoder on a toothed rack) or “Linear” (e.g. optical linear sensor). This selection defines the other parameters.

Measuring device: Defines the type of measuring device/sensors used. The following can be selected:

- › Encoder
- › Proximity switch
- › Encoder + proximity switch
- › Proximity 1 + Proximity 2
- › Encoder 1 + Encoder 2

Enable Direction: Select this parameter to activate the DIR output of the function block. This output is “1” (TRUE) if the axis is rotating counterclockwise and “0” (FALSE) if the axis is rotating clockwise (see adjacent figure).

Direction decision: Defines the direction of rotation for which the entered limits are activated. The following can be selected:

- Bidirectional
- Clockwise
- Counterclockwise

If “Bidirectional” is selected, the measurement is made on exceeding the limit entered, both clockwise and counterclockwise. If “Clockwise” or “Counterclockwise” is selected, the measurement is made only if the axis is rotating in the selected direction.

Thresholds number: Number of max. speed limits. When this value is changed, the number of limits is increased or decreased from at least 1 to a maximum of 4. If the number is greater than 1, the input pins for the selection of the specific limit appear in the bottom part of the function block.

Pitch: If the axis type “Linear” and the sensor type “Rotational” are selected, this field enables you to enter the pitch for converting the rotation of the sensor into the distance covered.

Proximity choice: Selecting the proximity switch enables you to select between PNP, NPN, NO contact, NC contact, 3-wire or 4-wire.

(To ensure Performance Level = PL e, a PNP NO must be used (see 7.1.3. Proximity switch input on speed monitoring modules SPM on page 32).

Encoder Resolution: Entry for the number of pulses/revolution (for a rotary sensor) or $\mu\text{m}/\text{pulse}$ (for a linear sensor) in relation to the 1st measuring device.

Verification: In this field, you can enter the number of pulses/revolution (for a rotary sensor) or $\mu\text{m}/\text{pulse}$ (for a linear sensor) in relation to the 2nd measuring device.

Gear Ratio: This parameter is active if there are two sensors on the selected axis. This parameter enables you to enter the gear ratio between the two sensors. If the two sensors are on the same moving object, the ratio is 1. Otherwise, the number must be entered regarding the ratio. Example: There is an encoder and a proximity switch, and the latter is on the moving object that (due to a gear ratio) moves at twice the speed of the encoder. For this reason, this value must be set to 2.

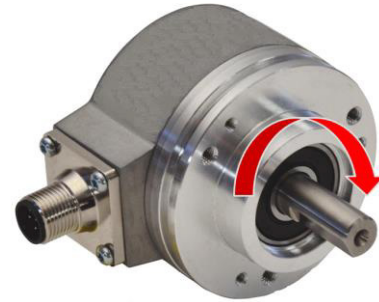

Figure 130: Example for the rotation of the axis clockwise

In1	Limits
0	Speed 1
1	Speed 2

Table 75: 2 limits set

In2	In1	Limits
0	0	Speed 1
0	1	Speed 2
1	0	Speed 3
1	1	Speed 4

Table 76: 4 limits set

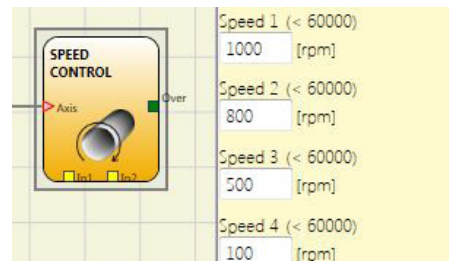

Figure 131: Pitch

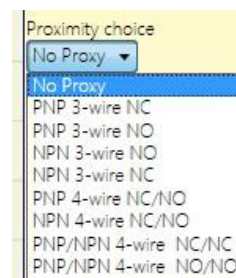

Figure 132: Proximity choice

Hysteresis (%): Corresponds to the hysteresis (in percent) below which a speed change is filtered out. A value other than 1 must be entered here to prevent constant switching when the input is changed.

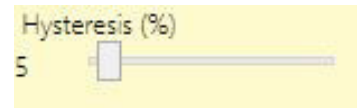

Figure 133: Hysteresis

Speed 1, 2, 3, 4: Enter the highest speed in this field. If the speed is exceeded, the OVER output of the function block is “0” (FALSE). If the measured speed is below the entered value, the OVER output of the function block is “1” (TRUE).

Frequency: Indicates the maximum calculated frequency values fM and fm (reduced by the entered hysteresis).

- If the indicated value is GREEN, the calculated frequency is in the correct range.
- If the indicated value is RED, the parameters given in the following formulas must be changed.

1. Rotary axis, rotary sensor. The calculated frequency is: $f[Hz] = \frac{rpm[rev/min]}{60} * Resolution[pulses/rev]$

2. Linear axis, rotary sensor. The calculated frequency is: $f[Hz] = \frac{speed[m/min] * 1000}{60 * pitch[mm/rev]} * Resolution[pulses/rev]$

3. Linear axis, linear sensor. The calculated frequency is: $f[Hz] = \frac{speed[mm/s] * 1000}{Resolution[\mu m/pulse]}$

4. Hysteresis. To be changed only if: fM = green; fm = red

KEY:
 f = Frequency
 rpm = Rotary speed
 $Resolution$ = Measurement
 $speed$ = Linear speed
 $pitch$ = Pitch

Enable Out Error: If activated, an error detected by the function block is signaled.

9.3.2. Speed range monitoring (WINDOW SPEED CONTROL)

The speed range monitoring function block checks the speed of a device; the WINDOW output is “1” (TRUE) if the measured speed is within the previously defined speed window.

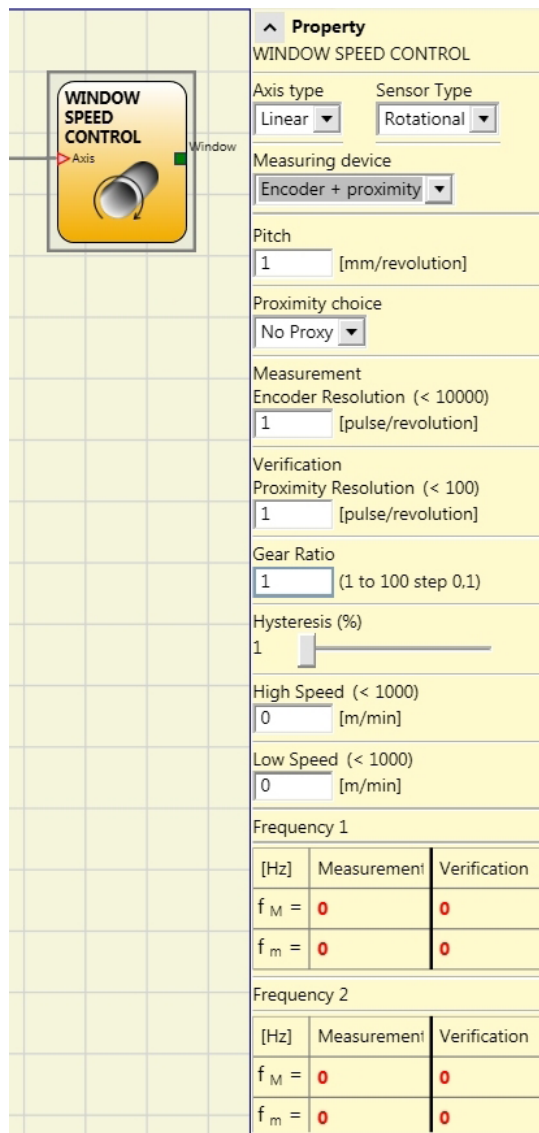

Figure 134: Speed range monitoring

Parameters

Axis type: Defines the type of axis that is monitored by the device. “Linear” if the movement is linear or “Rotational” if the movement is rotary.

Sensor Type: If “Linear” is selected for the previous parameter, the sensor type connected to the inputs of the module is defined here. This can be “Rotational” (e.g. encoder on a toothed rack) or “Linear” (e.g. optical linear sensor). This selection defines the other parameters.

Measuring device: This option specifies the type of measuring devices/sensors used. The following can be selected:

- Encoder
- Proximity switch
- Encoder + proximity switch
- Proximity 1 + Proximity 2
- Encoder 1 + Encoder 2

Pitch: If the axis type “Linear” and the sensor type “Rotational” are selected, this field becomes active. Enter here the distance that is covered during one sensor revolution.

Proximity choice: Selecting the proximity switch enables you to select between PNP, NPN, NO contact, NC contact, 3-wire or 4-wire.

To ensure Performance Level = PLe, a PNP NO must be used (see “Proximity switch input on speed monitoring modules SPM” on page 32).

Encoder Resolution: Entry for the number of pulses/revolution (for a rotary sensor) or μm/pulse (for a linear sensor) in relation to the 1st measuring device.

Verification: In this field, you can enter the number of pulses/revolution (for a rotary sensor) or μm/pulse (for a linear sensor) in relation to the 2nd measuring device.

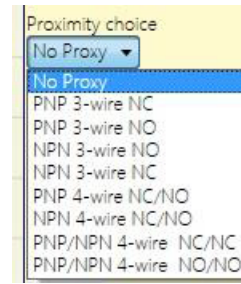

Figure 135: Proximity choice

Gear Ratio: This parameter is active if there are two sensors on the selected axis. This parameter enables you to enter the gear ratio between the two sensors. If the two sensors are on the same moving object, the ratio is 1; otherwise the figure for the ratio must be entered. Example: There is an encoder and a proximity switch, and the latter is on the moving object that (due to a gear ratio) moves at twice the speed of the encoder. For this reason, this value must be set to 2.

Hysteresis (%): Corresponds to the hysteresis (in percent) below which a speed change is filtered out. A value other than 1 must be entered here to prevent constant switching when the input is changed.

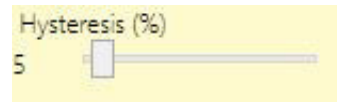

Figure 136: Hysteresis

High Speed: Enter the maximum value for the speed range in this field. Above this limit, the WINDOW output of the function block is “0” (FALSE). If the measured speed is below the value, but still above the “Low Speed” limit, the WINDOW output of the function block is “1” (TRUE).

Low Speed: Enter the minimum value for the speed range in this field. Below this limit, the WINDOW output of the function block is “0” (FALSE). If the measured speed is above the value, but still below the “High Speed” limit, the WINDOW output of the function block is “1” (TRUE).

Frequency: Indicates the maximum calculated frequency values fM and fm (reduced by the entered hysteresis).

- If the indicated value is GREEN, the calculated frequency is in the correct range.
- If the indicated value is RED, the parameters given in the following formulas must be changed.

1. Rotary axis, rotary sensor. The calculated frequency is:
$$f[\text{Hz}] = \frac{\text{rpm}[\text{rev}/\text{min}]}{60} * \text{Resolution}[\text{pulses}/\text{rev}]$$
2. Linear axis, rotary sensor. The calculated frequency is:
$$f[\text{Hz}] = \frac{\text{speed}[\text{m}/\text{min}] * 1000}{60 * \text{pitch}[\text{mm}/\text{rev}]} * \text{Resolution}[\text{pulses}/\text{rev}]$$
3. Linear axis, linear sensor. The calculated frequency is:
$$f[\text{Hz}] = \frac{\text{speed}[\text{mm}/\text{s}] * 1000}{\text{Resolution}[\mu\text{m}/\text{pulse}]}$$
4. Hysteresis. To be changed only if: fM = green; fm = red

KEY:
 f = Frequency
 rpm = Rotary speed
 $Resolution$ = Measurement
 $speed$ = Linear speed
 $pitch$ = Pitch

Enable Out Error: If activated, an error detected by the function block is signaled.

9.3.3. Standstill monitoring (STAND STILL)

The standstill monitoring function block checks the speed of a device; the ZERO output is “1” (TRUE) if the speed is 0. If the speed is not 0, the ZERO output is “0” (FALSE).

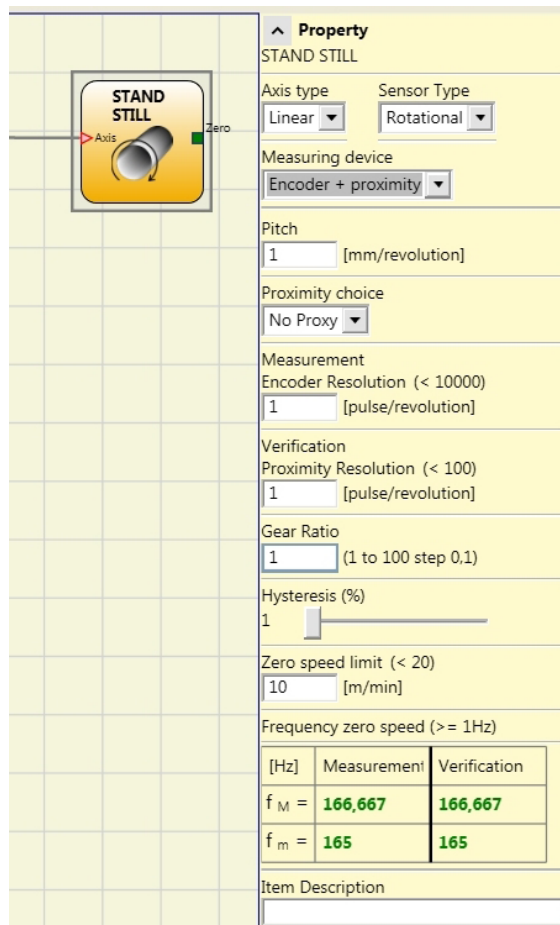

Figure 137: Standstill monitoring

Parameters

Axis type: Defines the type of axis that is monitored by the device. “Linear” if the movement is linear or “Rotational” if the movement is rotary.

Sensor Type: If “Linear” is selected for the previous parameter, the sensor type connected to the inputs of the module is defined here. This can be “Rotational” (e.g. encoder on a toothed rack) or “Linear” (e.g. optical linear sensor). This selection defines the other parameters.

Measuring device: This option specifies the type of measuring devices/sensors used. The following can be selected:

- Encoder
- Proximity switch
- Encoder + proximity switch
- Proximity 1 + Proximity 2
- Encoder 1 + Encoder 2

Pitch: If the axis type “Linear” and the sensor type “Rotational” are selected, this field becomes active. Enter here the distance that is covered during one sensor revolution.

Proximity choice: Selecting the proximity switch enables you to select between PNP, NPN, NO contact, NC contact, 3-wire or 4-wire.

(To ensure Performance Level = PLe, a PNP NO must be used (see "Proximity switch input on speed monitoring modules SPM" on page 32).

Encoder Resolution: Entry for the number of pulses/revolution (for a rotary sensor) or μm/pulse (for a linear sensor) in relation to the 1st measuring device.

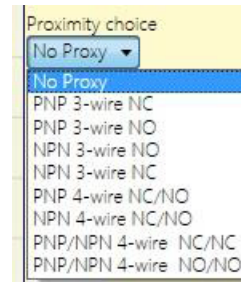

Figure 138: Proximity choice

Verification: In this field, you can enter the number of pulses/revolution (for a rotary sensor) or μm/pulse (for a linear sensor) in relation to the 2nd measuring device.

Gear Ratio: This parameter is active if there are two sensors on the selected axis. This parameter enables you to enter the gear ratio between the two sensors. If the two sensors are on the same moving object, the ratio is 1; otherwise the figure for the ratio must be entered. Example: There is an encoder and a proximity switch, and the latter is on the moving object that (due to a gear ratio) moves at twice the speed of the encoder. For this reason, this value must be set to 2.

Hysteresis (%): Corresponds to the hysteresis (in percent) below which a speed change is filtered out. A value other than 1 must be entered here to prevent constant switching when the input is changed.

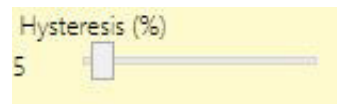

Figure 139: Hysteresis

Zero speed limit: Enter the highest speed that still corresponds to standstill in this field. Above this limit, the ZERO output of the function block is "0" (FALSE). If the measured speed is below the entered value, the ZERO output of the function block is "1" (TRUE).

Frequency zero speed: Indicates the maximum calculated frequency values *fM* and *fm* (reduced by the entered hysteresis).

- If the indicated value is GREEN, the calculated frequency is in the correct range.
- If the indicated value is RED, the parameters given in the following formulas must be changed.

1. Rotary axis, rotary sensor. The calculated frequency is:
$$f[\text{Hz}] = \frac{\text{rpm}[\text{rev}/\text{min}]}{60} * \text{Resolution}[\text{pulses}/\text{rev}]$$
 2. Linear axis, rotary sensor. The calculated frequency is:
$$f[\text{Hz}] = \frac{\text{speed}[\text{m}/\text{min}] * 1000}{60 * \text{pitch}[\text{mm}/\text{rev}]} * \text{Resolution}[\text{pulses}/\text{rev}]$$
 3. Linear axis, linear sensor. The calculated frequency is:
$$f[\text{Hz}] = \frac{\text{speed}[\text{mm}/\text{s}] * 1000}{\text{Resolution}[\mu\text{m}/\text{pulse}]}$$
 4. Hysteresis. To be changed only if: *fM* = green; *fm* = red
- KEY:
f = Frequency
rpm = Rotary speed
Resolution = Measurement
speed = Linear speed
pitch = Pitch

Enable Out Error: If activated, an error detected by the function block is signaled.

9.3.4. Speed/standstill monitoring (STAND STILL AND SPEED CONTROL)

The speed/standstill monitoring function block checks the speed of a device by the ZERO output becoming “1” when the speed is 0. In addition, the OVER output is “0” (FALSE) if the measured speed exceeds a previously defined limit.

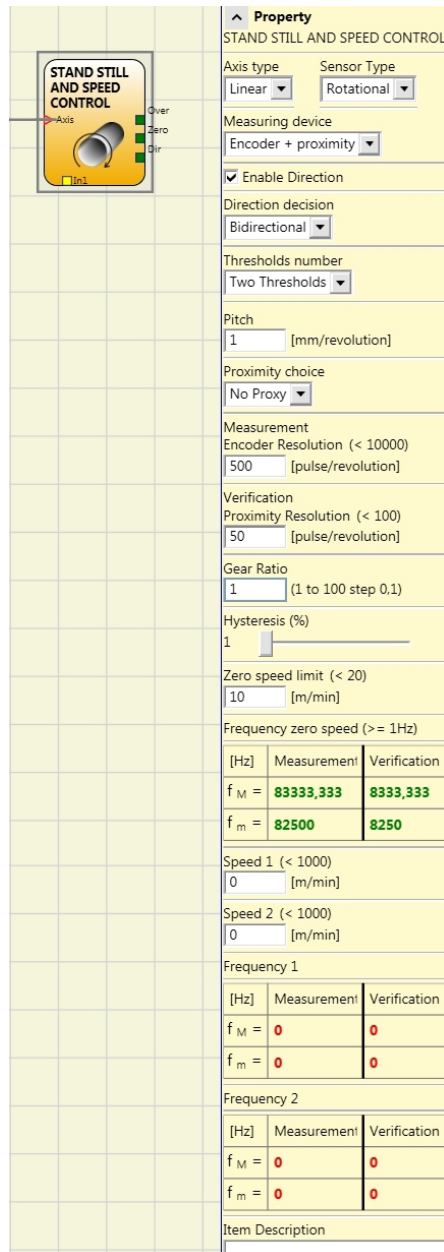

Figure 140: Speed/standstill monitoring

Parameters

Axis type: Defines the type of axis that is monitored by the device. “Linear” if the movement is linear or “Rotational” if the movement is rotary.

Sensor Type: If “Linear” is selected for the previous parameter, the sensor type connected to the inputs of the module is defined here. This can be “Rotational” (e.g. encoder on a toothed rack) or “Linear” (e.g. optical linear sensor). This selection defines the other parameters.

Measuring device: Defines the type of measuring device/sensors used. The following can be selected:

- Encoder
- Proximity switch
- Encoder + proximity switch
- Proximity 1 + Proximity 2
- Encoder 1 + Encoder 2

Enable Direction: Select this parameter to activate the DIR output of the function block. This output is “1” (TRUE) if the axis is rotating counterclockwise and “0” (FALSE) if the axis is rotating clockwise (see adjacent figure).

Direction decision: Defines the direction of rotation for which the entered limits are activated. The following can be selected:

- Bidirectional
- Clockwise
- Counterclockwise

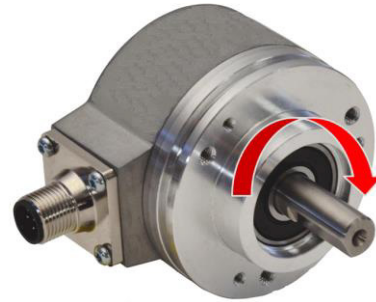

Figure 141: Example for the rotation of the axis clockwise

If “Bidirectional” is selected, the measurement is made on exceeding the limit entered, both clockwise and counterclockwise. If “Clockwise” or “Counterclockwise” is selected, the measurement is made only if the axis is rotating in the selected direction.

Thresholds number: Number of max. speed limits. When this value is changed, the number of limits is increased or decreased from at least 1 to a maximum of 4. If the number is greater than 1, the input pins for the selection of the specific limit appear in the bottom part of the function block.

In1	Limits
0	Speed 1
1	Speed 2

Table 77: 2 limits set

In2	In1	Limits
0	0	Speed 1
0	1	Speed 2
1	0	Speed 3
1	1	Speed 4

Table 78: 4 limits set

Pitch: If the axis type “Linear” and the sensor type “Rotational” are selected, this field enables you to enter the pitch for converting the rotation of the sensor into the distance covered.

Proximity choice: Selecting the proximity switch enables you to select between PNP, NPN, NO contact, NC contact, 3-wire or 4-wire.

To ensure Performance Level = PL e, a PNP NO must be used (see “Proximity switch input on speed monitoring modules SPM” on page 32).

Frequency zero speed / Frequency 1 / Frequency 2: Indicates the maximum calculated frequency values fM and fm (reduced by the entered hysteresis).

- If the indicated value is GREEN, the calculated frequency is in the correct range.
- If the indicated value is RED, the parameters given in the following formulas must be changed.

1. Rotary axis, rotary sensor. The calculated frequency is:
$$f[\text{Hz}] = \frac{\text{rpm}[\text{rev}/\text{min}]}{60} * \text{Resolution}[\text{pulses}/\text{rev}]$$
2. Linear axis, rotary sensor. The calculated frequency is:
$$f[\text{Hz}] = \frac{\text{speed}[\text{m}/\text{min}] * 1000}{60 * \text{pitch}[\text{mm}/\text{rev}]} * \text{Resolution}[\text{pulses}/\text{rev}]$$
3. Linear axis, linear sensor. The calculated frequency is:
$$f[\text{Hz}] = \frac{\text{speed}[\text{mm}/\text{s}] * 1000}{\text{Resolution}[\mu\text{m}/\text{pulse}]}$$
4. Hysteresis. To be changed only if: fM = green; fm = red

KEY:
 f = Frequency
 rpm = Rotary speed
 Resolution = Measurement
 speed = Linear speed
 pitch = Pitch

Encoder Resolution: Entry for the number of pulses/revolution (for a rotary sensor) or $\mu\text{m}/\text{pulse}$ (for a linear sensor) in relation to the 1st measuring device.

Verification: In this field, you can enter the number of pulses/revolution (for a rotary sensor) or $\mu\text{m}/\text{pulse}$ (for a linear sensor) in relation to the 2nd measuring device.

Gear Ratio: This parameter is active if there are two sensors on the selected axis. This parameter enables you to enter the gear ratio between the two sensors. If the two sensors are on the same moving object, the ratio is 1; otherwise the figure for the ratio must be entered. Example: There is an encoder and a proximity switch, and the latter is on the moving object that (due to a gear ratio) moves at twice the speed of the encoder. For this reason, this value must be set to 2.

Hysteresis (%): Corresponds to the hysteresis (in percent) below which a speed change is filtered out. A value other than 1 must be entered here to prevent constant switching when the input is changed.

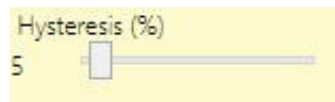

Figure 142: Hysteresis

Zero speed limit: In this field, enter the highest speed above which the output of the function block ZERO is "0" (FALSE). If the measured speed is below the entered value, the ZERO output of the function block is "1" (TRUE).

Speed 1, 2, 3, 4: Enter the highest speed in this field. If the speed is exceeded, the OVER output of the function block is "0" (FALSE). If the measured speed is below the entered value, the OVER output of the function block is "1" (TRUE).

Enable Out Error: If activated, an error detected by the function block is signaled.

9.4. Function blocks in the “OPERATOR” window

All inputs on these operators can be inverted (logical NOT). To invert, click the input that is to be inverted using the right mouse button. A small circle then appears on the inverted input. To clear the inversion, simply click the same input again.



Important!

The maximum permissible number of function blocks is 64.

9.4.1. Logical operators

9.4.1.1. AND

The logical operator AND produces an output of “1” (TRUE) if all inputs are “1” (TRUE).

IN ₁	IN ₂	IN _x	OUT
0	0	0	0
1	0	0	0
0	1	0	0
1	1	0	0
0	0	1	0
1	0	1	0
0	1	1	0
1	1	1	1

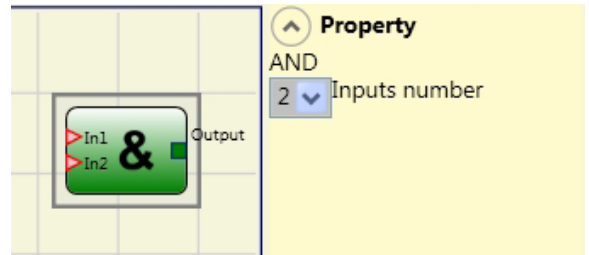

Figure 143: AND

Parameters

Inputs number: Use this option to set 2 to 8 inputs.

9.4.1.2. NAND

The logical operator NAND produces an output of “0” (FALSE) if all inputs are “1” (TRUE).

IN ₁	IN ₂	IN _x	OUT
0	0	0	1
1	0	0	1
0	1	0	1
1	1	0	1
0	0	1	1
1	0	1	1
0	1	1	1
1	1	1	0

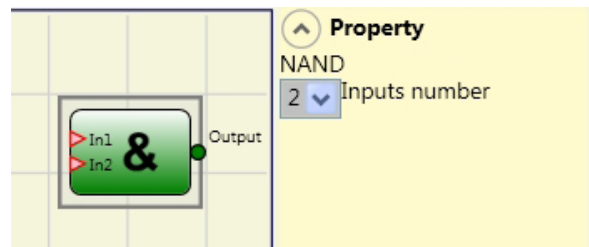

Figure 144: NAND

Parameters

Inputs number: Use this option to set 2 to 8 inputs.

9.4.1.3. NOT

The logical status of the input is inverted using the logical NOT operator.

IN ₁	OUT
0	1
1	0

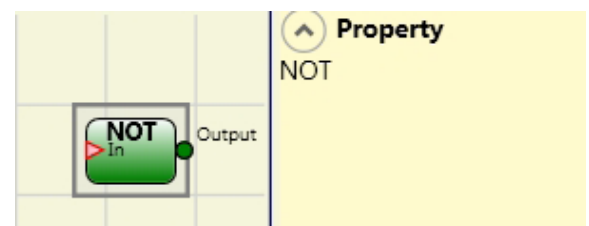

Figure 145: NOT

9.4.1.4. OR

The logical operator OR produces an output of "1" (TRUE) if at least one of the inputs is "1" (TRUE).

IN ₁	IN ₂	IN _x	OUT
0	0	0	0
1	0	0	1
0	1	0	1
1	1	0	1
0	0	1	1
1	0	1	1
0	1	1	1
1	1	1	1

Parameters

Inputs number: Use this option to set 2 to 8 inputs.

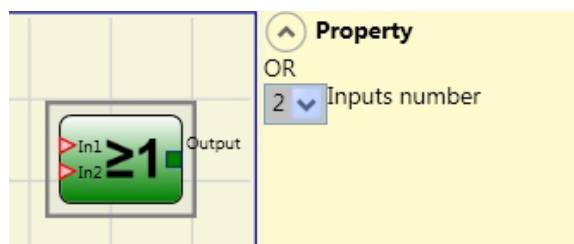

Figure 146: OR

9.4.1.5. NOR

The logical operator NOR produces an output of "0" (FALSE) if at least one of the inputs is "1" (TRUE).

IN ₁	IN ₂	IN _x	OUT
0	0	0	1
1	0	0	0
0	1	0	0
1	1	0	0
0	0	1	0
1	0	1	0
0	1	1	0
1	1	1	1

Parameters

Inputs number: Use this option to set 2 to 8 inputs.

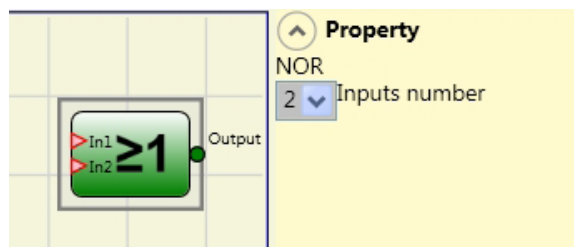

Figure 147: NOR

9.4.1.6. XOR

The logical operator XOR produces an output of "0" (FALSE) if the number of inputs that are "1" (TRUE) is even or if all inputs are "0" (FALSE).

IN ₁	IN ₂	IN _x	OUT
0	0	0	0
1	0	0	1
0	1	0	1
1	1	0	0
0	0	1	1
1	0	1	0
0	1	1	0
1	1	1	1

Parameters

Inputs number: Use this option to set 2 to 8 inputs.

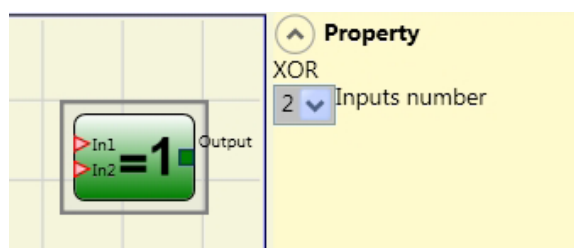

Figure 148: XOR

9.4.1.7. XNOR

The logical operator XNOR produces an output of “0” (FALSE) if the number of inputs that are “1” (TRUE) is even or if all inputs are “0” (FALSE).

IN ₁	IN ₂	IN _x	OUT
0	0	0	1
1	0	0	0
0	1	0	0
1	1	0	1
0	0	1	0
1	0	1	1
0	1	1	1
1	1	1	0

Parameters

Inputs number: Use this option to set 2 to 8 inputs.

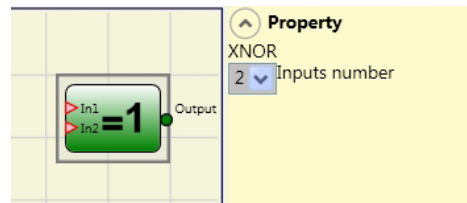

Figure 149: XNOR

9.4.1.8. Logical macro (LOGICAL MACRO)

This operator permits the grouping of two or three logic blocks.

A maximum of 8 inputs are available.

The result of the first two operators flows into a third operator; the result of this operator is output on the OUTPUT output.

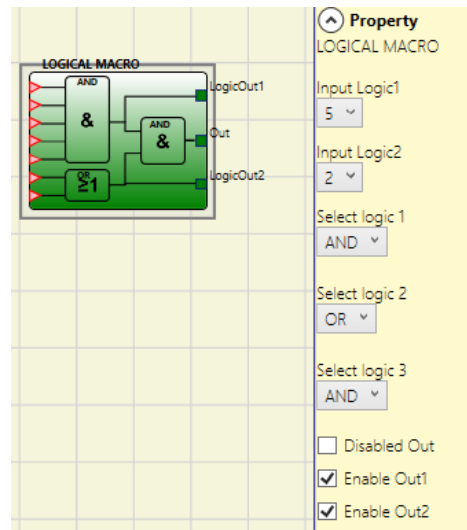

Figure 150: Logical macro

Parameters

Input Logic 1, 2: Use this option to set the number of logic inputs (1 to 7).

If one of the two logic inputs has only one input, the corresponding logic is deactivated and the input is assigned directly to the final logic (example in the adjacent figure).

Select logic 1, 2, 3: This enables the operator type to be selected from the following options: AND, NAND, OR, NOR, XOR, XNOR.

Deactivate main output: If this option is selected, the main output OUT is deactivated.

Activation of Output1, Output2: Select this option to display intermediate results. (see Figure 150)

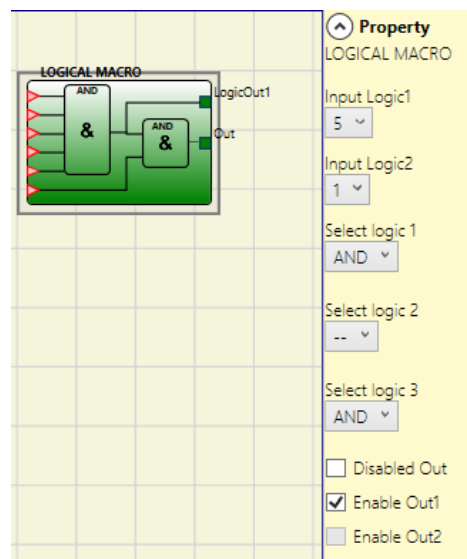

Figure 151: Logical macro parameter

9.4.1.9. MULTIPLEXER

Using the MULTIPLEXER logical operator, the input signal sent to the output depends on the SEL selection. If only one bit is set for Sel1–Sel4, the selected input is connected to the output. If:

- More than one SEL input = “1” (TRUE) or
- No SEL input = “1” (TRUE),

Then the output switches to “0” (FALSE), and that independent of the input values.

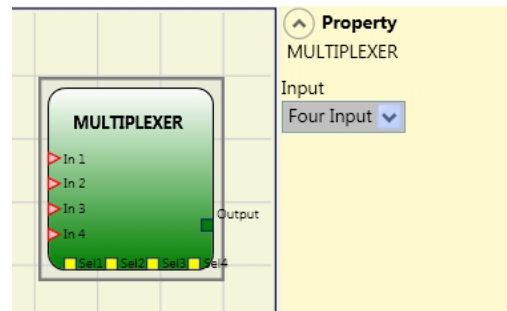

Figure 152: Multiplexer

Parameters

Inputs number: Use this option to set 2 to 4 inputs.

9.4.1.10. Digital comparator (DIGITAL COMPARATOR) (only with MSC-CB-S)

The DIGITAL COMPARATOR operator can compare a signal group in binary format with a constant or with a second signal group.

Comparison with a constant

The signal comparison must not be selected for the comparison with a constant. The DIGITAL COMPARATOR operator compares a signal group with an integer constant. Inputs In1 to In8 produce a binary value. In1 is the LSB (least significant bit) and In8 the MSB (most significant bit).

Example for 8 inputs:

Input	Value
In1	0
In2	1
In3	1
In4	0
In5	1
In6	0
In7	0
In8	1

➔ This results in the binary number 01101001, which represents the decimal value 150.

Example for 5 inputs:

Input	Value
In1	0
In2	1
In3	0
In4	1
In5	1

➔ This results in the binary number 01011, which represents the decimal value 26.

Parameters

Inputs number: Setting 2 to 8 inputs

Operation: Choice between equal to (=), unequal to (!=), greater than (>), greater than or equal to (>=), less than (<) and less than or equal to (<=) (refer to the table for an exact description)

Constant: Setting value from 0 to 255

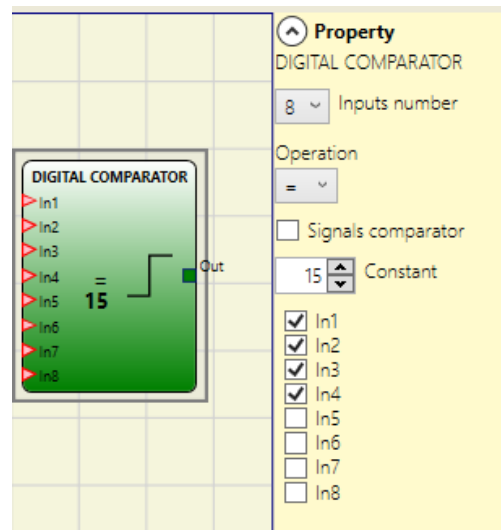

Figure 153: Digital comparator, comparison with a constant

Operator	Description
Equal to (=)	The OUTPUT output is "1" (TRUE) if the value combined from the inputs is equal to the constant. If the two values are not equal, the OUTPUT output = "0" (FALSE).
Unequal to (!=)	The OUTPUT output is "1" (TRUE) if the value combined from the inputs is not equal to the constant. If the values are equal, the OUTPUT output = "0" (FALSE).
Greater than (>)	The OUTPUT output is "1" (TRUE) if the value combined from the inputs is larger than the value of the constant. If the constant is the same or larger, the OUTPUT output = "0" (FALSE).
Greater than or equal to (>=)	The OUTPUT output is "1" (TRUE) if the value combined from the inputs is larger than or the same as the value of the constant. If the constant is larger, the OUTPUT output = "0" (FALSE).
Less than (<)	The OUTPUT output is "1" (TRUE) if the value combined from the inputs is smaller than the value of the constant. If the constant is the same or smaller, the OUTPUT output = "0" (FALSE).
Less than or equal to (<=)	The OUTPUT output is "1" (TRUE) if the value combined from the inputs is smaller than or the same as the value of the constant. If the constant smaller, the OUTPUT output = "0" (FALSE).

Comparison with a second signal group

The signal comparison must be selected for the comparison with a second signal group. Inputs In1_A to In4_A produce the value A. In1_A is the LSB and In4_A the MSB of the binary value. Inputs In1_B to In4_B produce the value B. In1_B is the LSB and In4_B the MSB of the binary value.

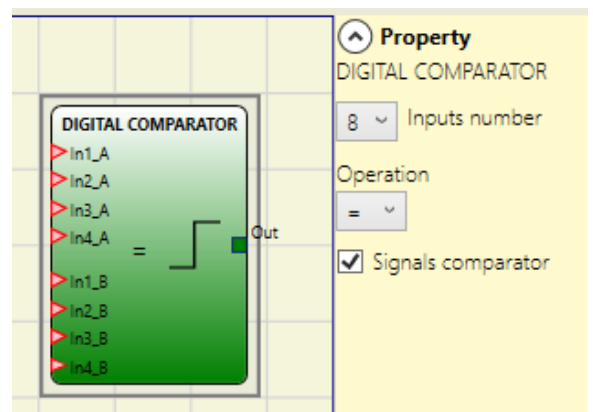

Figure 154: Digital comparator, signal comparison

Parameters

Operation: Choice between equal to (=), unequal to (!=), greater than (>), greater than or equal to (>=), less than (<) and less than or equal to (<=) (refer to the table for an exact description)

Operator	Description
Equal to (=)	The OUTPUT output is "1" (TRUE) if value A is equal to value B. If the two values are not equal, the OUTPUT output = "0" (FALSE).
Unequal to (!=)	The OUTPUT output is "1" (TRUE) if value A is not equal to value B. If the values are equal, the OUTPUT output = "0" (FALSE).
Greater than (>)	The OUTPUT output is "1" (TRUE) if value A is larger than value B. If value B is the same or larger, the OUTPUT output = "0" (FALSE).
Greater than or equal to (>=)	The OUTPUT output is "1" (TRUE) if value A is larger than or the same as value B. If the value B is larger, the OUTPUT output = "0" (FALSE).
Less than (<)	The OUTPUT output is "1" (TRUE) if value A is smaller than value B. If value B is the same or smaller, the OUTPUT output = "0" (FALSE).
Less than or equal to (<=)	The OUTPUT output is "1" (TRUE) if value A is smaller than or the same as value B. If value B is smaller, the OUTPUT output = "0" (FALSE).

9.4.2. Memory operators

Operators of the type MEMORY make it possible to save data (TRUE or FALSE) that come from other project components. Status changes are performed according to the truth tables given for each operator.

9.4.2.1. D FLIP FLOP (max. number = 16 with MSC-CB, max. number = 32 with MSC-CB-S)

Using the D FLIP-FLOP operator the status set previously on the Q output is saved according to the following truth table.

Preset	Clear	Ck	D	Q
1	0	X	X	1
0	1	X	X	0
1	1	X	X	0
0	0	L	X	Retain memory
0	0	Rising edge	1	1
0	0	Rising edge	0	0

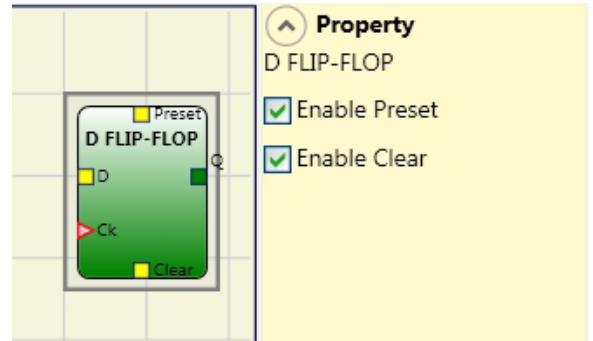

Figure 155: D Flip-Flop

Parameters

Enable Preset: If activated, the Q output can be set to “1” (TRUE).

Enable Clear: If activated, the memory process can be reset.

9.4.2.2. T FLIP FLOP (max. number = 16 with MSC-CB, max. number = 32 with MSC-CB-S)

This operator toggles the Q output on each rising edge on the T (Toggle) input .

Parameters

Enable Clear: If activated, the memory process can be reset.

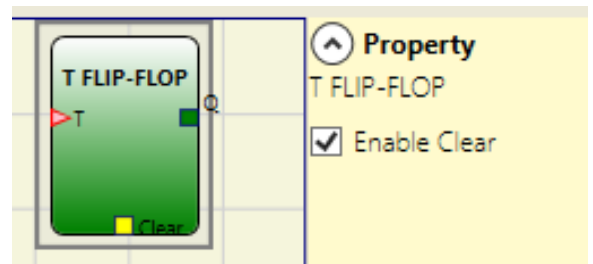

Figure 156: T Flip-Flop

9.4.2.3. SR FLIP-FLOP

Using the SR FLIP-FLOP operator, the Q output is set to “1” with Set and to “0” with Reset.

See truth table below:

SET	RESET	Q
0	0	Retain memory
0	1	0
1	0	1
1	1	0

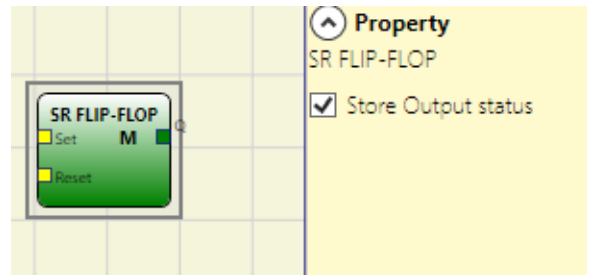

Figure 157: SR Flip-Flop

Parameters

Save output status: If this is selected, the output status of the flip-flop is saved in the non-volatile memory on every change. The most recently saved value is restored with the MSC system is switched on. Up to 8 flip-flops with storage of the output status are possible. They are distinguished by an “M.”



NOTICE

- › The user must bear a few limitations in mind when using this memory type. The maximum required time for a single saving operation is estimated at 50 ms, and the maximum number of possible saving operations is fixed at 100,000.
- › The total number of storage operations must not exceed the limit, otherwise this will shorten the product’s mechanical life. Furthermore, the frequency of storage operations must be low enough to permit them under safe conditions.

9.4.2.4. Manual restart (USER RESTART MANUAL) (max. number = 16 with MSC-CB, max. number = 32 with MSC-CB-S including other RESTART operators)

Using the USER RESTART MANUAL operator the restart signal is saved as per the following truth table.

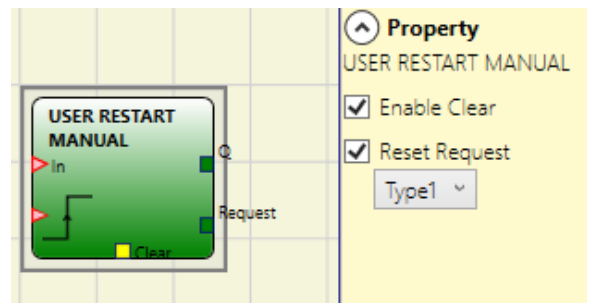

Figure 158: Manual restart

Clear	Restart	IN	Q	Restart request type 1	Restart request type 2
1	X	X	0	0	1
X	X	0	0	0	1
0	0	1	Retain memory	1	Flashing at 1 Hz
0	Rising edge	1	1	0	0

Parameters

Enable Clear: If activated, the memory process can be reset.

Reset Request: If activated, this can indicate that restarting is possible. The behavior can correspond to that of type 1 or type 2.



Important!

In case of request output type 2, a system timer is used.

9.4.2.5. Monitored restart (USER RESTART MONITORED) (max. number = 16 with MSC-CB, max. number = 32 with MSC-CB-S including other RESTART operators)

Using the USER RESTART MONITORED operator the restart signal is saved as per the following truth table.

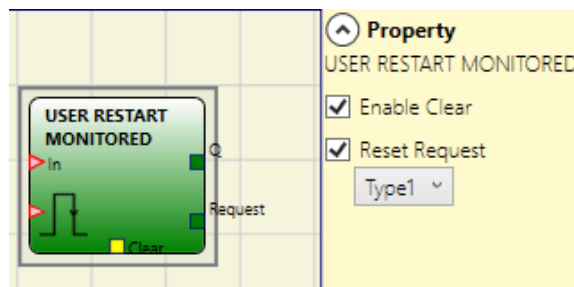



Figure 159: Monitored restart

Clear	Restart 	IN	Q	Restart request type 1	Restart request type 2
1	X	X	0	0	1
X	X	0	0	0	1
0	0	1	Retain memory	1	Flashing at 1 Hz
0		1	1	0	0

Parameters

Enable Clear: If activated, the memory process can be reset.

Reset Request: If activated, this can indicate that restarting is possible. The behavior can correspond to that of type 1 or type 2.



Important!

In case of request output type 2, a system timer is used.

9.4.2.6. Manual restart macro (MACRO RESTART MANUAL) (max. number = 16 with MSC-CB, max. number = 32 with MSC-CB-S including other RESTART operators)

Using the MACRO RESTART MANUAL operator, a logic block selected by the user can be combined with the manual restart function block ("USER RESTART MANUAL") as per the following truth table:

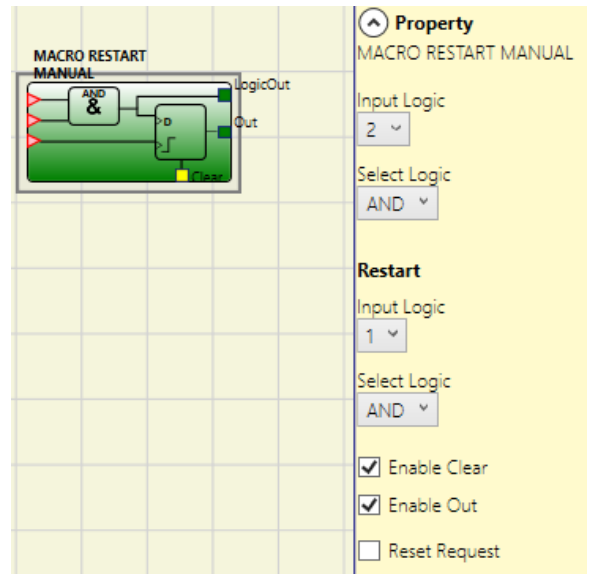



Figure 160: Macro manual restart

Clear	Restart 	Input	Output	Restart request
1	X	X	0	0
X	X	0	0	0
0	0	1	Retain memory	1
0	Rising edge	1	1	0

Parameters

Input Logic: Use this option to set the number of logic inputs used (2 to 7).

Select Logic: This enables the operator type to be selected from the following options: AND, NAND, OR, NOR, XOR, XNOR.

Enable Clear: The memory process can be reset if this option is selected.

Enable Out: Select this option to display intermediate result of the logic.

Reset Request: If activated, this can indicate that restarting is possible.

Restart Input Logic: Use this option to set the number of reset logic inputs used (1 to 7). If 1 is selected, the logic is not taken into account.

Restart Select Logic: Permits selection of the operator type for the restart logic from the following options: AND, NAND, OR, NOR, XOR, XNOR.

9.4.2.7. Macro monitored restart (MACRO RESTART MONITORED) (max. number = 16 with MSC-CB, max. number = 32 with MSC-CB-S including other RESTART operators)

Using the MACRO RESTART MONITORED operator, a logic block selected by the user can be combined with the monitored restart function block ("USER RESTART MONITORED") as per the following truth table:

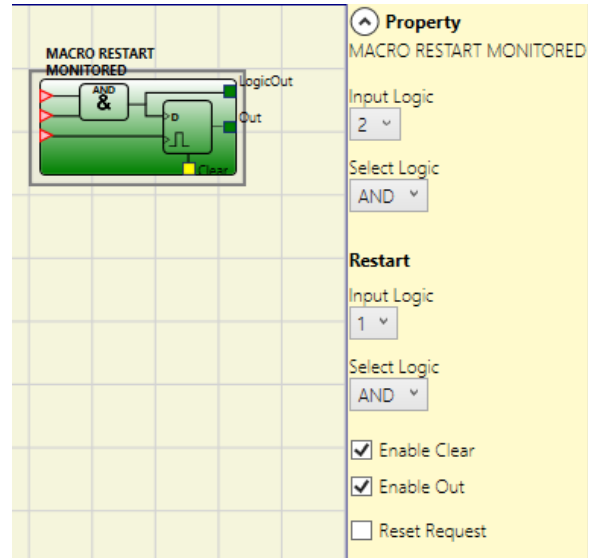



Figure 161: Macro-monitored restart

Clear	Restart 	Input	Output	Restart request
1	X	X	0	0
X	X	0	0	0
0	0	1	Retain memory	1
0		1	1	0

Parameters

Input Logic: Use this option to set the number of logic inputs used (2 to 7).

Select Logic: This enables the operator type to be selected from the following options: AND, NAND, OR, NOR, XOR, XNOR.

Enable Clear: If activated, the memory process can be reset.

Enable Out: Select this option to display intermediate result of the logic.

Reset Request: If activated, this can indicate that restarting is possible.

Restart Input Logic: Use this option to set the number of reset logic inputs used (1 to 7). If 1 is selected, the logic is not taken into account.

Restart Select Logic: Permits selection of the operator type for the restart logic from the following options: AND, NAND, OR, NOR, XOR, XNOR.

9.4.2.8. PRE-RESET (only MSC-CB-S, max. number = 32 including other restart operators)

The PRE-RESET operator can be used if several reset buttons must be used. For example, it may be necessary to locate a restart switch (pre-reset) in the danger zone (at a point from which the entire zone is visible) and a restart switch (reset) outside the danger zone.

The 0-1-0 transitions must occur in sequence for the pre-reset and the reset. The reset transitions must occur within 500 ms to 5 s after the pre-reset transitions.

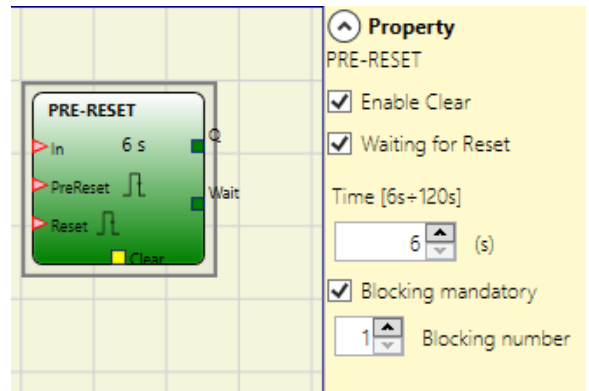

Figure 162: Pre-reset

Parameters

Enable Clear: If activated, the memory process can be reset.

Waiting for Reset: If activated, another output will become available. This becomes “1” (TRUE) when the pre-reset completes the 0-1-0 transition and becomes “0” (FALSE) when the operator is reset or the time between the transitions of the two inputs elapses.

Time: Maximum duration of the transition 0 - 1 - 0 (6 - 120 s can be set).

Signal interruptions: If activated, a number of interruptions in the signal (max. 7) can be specified. Output Q is set if the signal had fewer interruptions (1 - 0 - 1 transitions) than the specified number of interruptions but had at least one interruption.

The behavior of the operator is shown in the following time sequences:

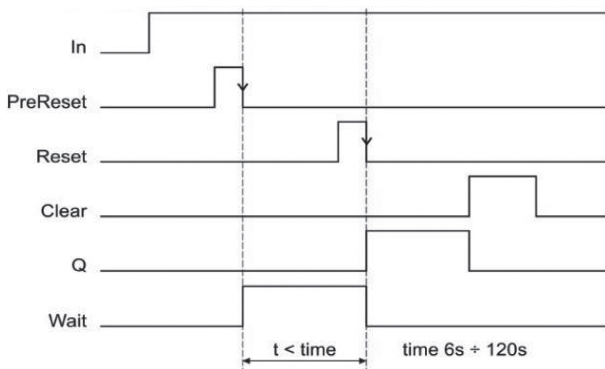

Figure 163: Pre-reset without signal interruptions

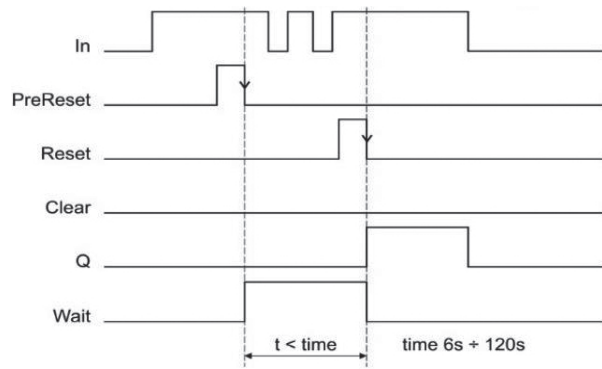

Figure 164: Pre-reset with signal interruptions (number of activations = 2)

9.4.3. Guard locking operators

9.4.3.1. Guard locking logic (GUARD LOCK) (max. number with MSC-CB = 4, max. number with MSC-CB-S = 8)

Using the GUARD LOCK operator the locking/release of an ELECTROMECHANICAL GUARD LOCK is monitored. For this purpose it is checked whether the locking command and the status of an INTERLOCK and FEEDBACK match. The main output (OUTPUT) is "1" (TRUE) if the guard lock is closed and locked.

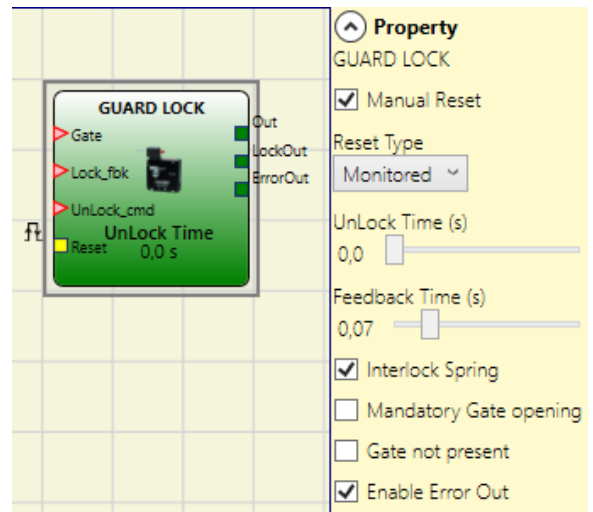

Figure 165: Guard lock logic

Principle of operation

The function operates as guard locking monitoring.

1. The GATE input must always be connected to a interlock input of type interlock (INTERLOCK) (feedback from the door).
2. The Lock_fbk input must always be connected to an input element of type guard locking monitoring (LOCK FEEDBACK) (feedback from the locking element).
3. The UnLock_cmd input can be connected as required in the diagram and determines the unlock request (if logical "1").
4. The OUTPUT output on this element is "1" (TRUE) if the guard locking is closed and locked. If there is an unlock command present on the UnLock_cmd input, the OUTPUT signal is set to "0" and the locking (Lock-Out output signal) is removed after the time set in Unlock Time (s). The OUTPUT signal is set to "0" ("FALSE") if an erroneous state is present (e.g. door open when locked; feedback loop timeout elapsed; ...).
5. The Lock-Out signal controls the locking of the safety door.

Parameters

Manual Reset: There are two types of reset: Manual and Monitored. On the selection of manual reset, only the signal transition from 0 to 1 is checked. With monitored reset, the double transition from 0 to 1 and then back to 0 is checked.



Figure 166: Guard locking logic manual/monitored reset



WARNING

If manual reset is selected, the next input after the inputs used by the function block must be used. Example: If Input1 and Input2 are used for the function block, Input3 must be used for the reset input.

Unlock Time (s): The time that elapses between the activation of the Unlock_cmd input and the actual release of the locking.

- 0 ms to 1 s – 100 ms step
- 1.5 s to 10 s – 0.5 s step
- 15 s to 25 s – 5 s step

Feedback Time: Maximum time delay between the LockOut output and the Lock_fbk input (as stated in the data sheet for the guard locking, with required delay).

- 10 ms to 100 s – 10 ms step size
- 150 ms to 1 s – 50 ms step size
- 1.5 s to 3 s – 0.5 s step size

Mechanically locked (closed-circuit current): The guard lock is locked passively and released actively, i.e. it is locked by the mechanical force in the spring. The guard lock therefore remains locked after interruption of the power supply.

Safety door must be opened once: The cycle is resumed only after the door is opened and this is then confirmed on the GATE input.

No door: If selected, the GATE input will be deactivated.

Enable Error Out: This option can be activated to enable a signal (Error OUT) for signaling a malfunction in the locking. If Error OUT = "1" (TRUE), there is an error in the locking.

9.4.4. COUNTER operators

The operators of type COUNTER enable the user to generate a signal (TRUE) as soon as the count entered is reached.

9.4.4.1. Counter (COUNTER) (max. number = 16)

The COUNTER operator is a pulse counter.

There are three operating modes:

1. AUTOMATIC
2. MANUAL
3. MANUAL+AUTOMATIC

In the following examples the counter value is 6:

1. The counter generates a pulse with the length of two internal cycles as soon as the entered counter value is reached. This is the default mode if the CLEAR pin is not activated.

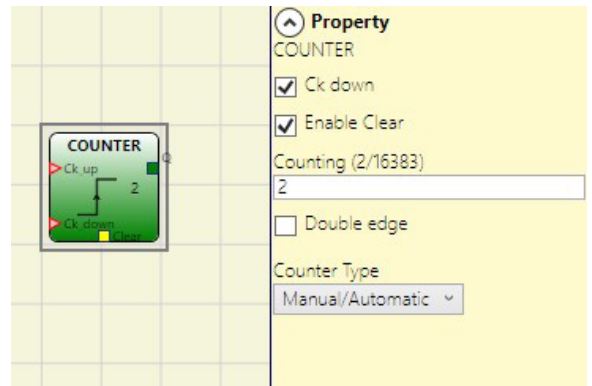

Figure 167: Counter

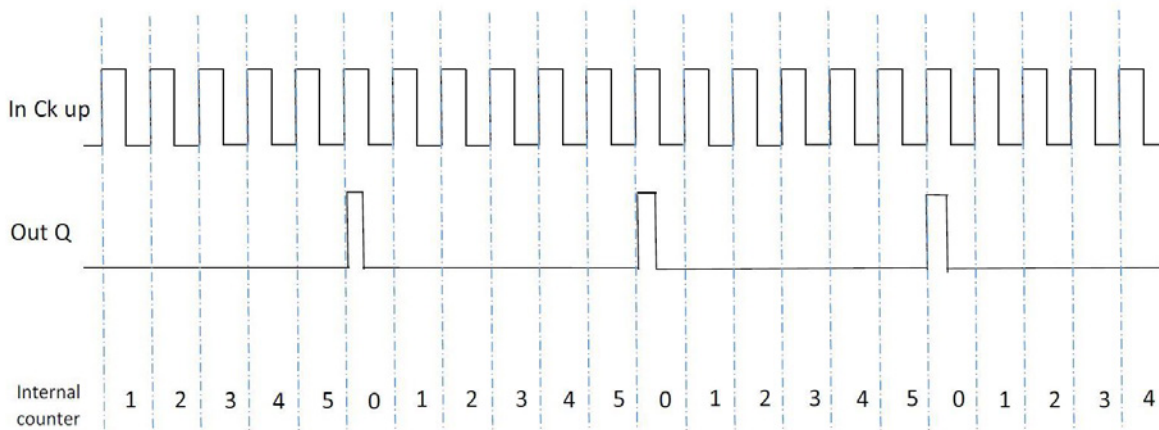

Figure 168: Use of the counter without reset input

2. The counter sets the Q output to "1" (TRUE) as soon as the entered counter value is reached. The Q output changes to "0" (FALSE) if the CLEAR signal is activated.

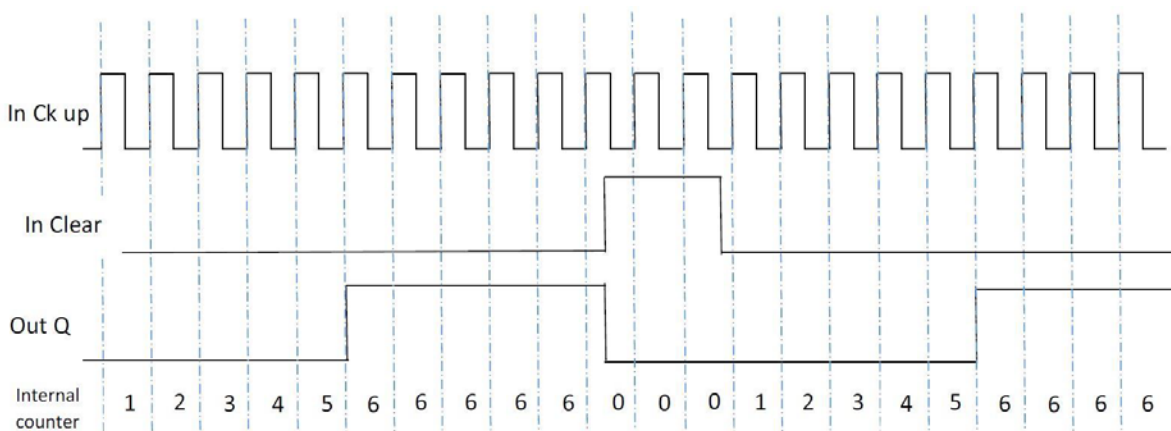

Figure 169: Use of the counter with CLEAR signal for resetting the output

- The counter generates a pulse length that corresponds to the reaction time as soon as the count entered is reached. If the CLEAR signal is activated, the internal counter returns to 0.

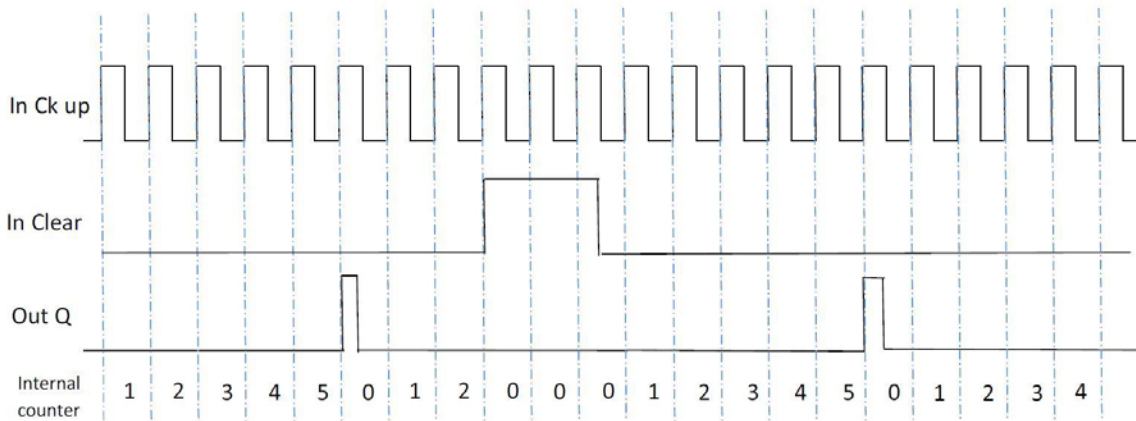

Figure 170: Use of the counter with CLEAR signal for resetting the counter input

Parameters

Enable Clear: If this option is selected, the clear request is activated to restart the count by setting the Q output to “0” again (FALSE). It is also possible to activate the automatic function (Automatic Enable) using manual reset.

If not selected, the operating mode is then automatic and, on reaching the entered count, the output changes to “1” (TRUE) and remains there for two internal cycles. It is then reset.

Ck down: Selects counting down.

Double edge: If activated, rising and falling edges are counted.

Counter status: If selected, the current counter value can be forwarded via the COUNTER output to the COUNTER COMPARATOR block.

9.4.4.2. Timer value comparison (COUNTER COMPARATOR) (only MSC-CB-S and MSC-CB ≥ 4.0)

The COUNTER COMPARATOR operator enables the Counter output of the COUNTER operator to be compared with a threshold.

If the counter value of the COUNTER operator is less than the threshold, the output is “0” (FALSE).

If the counter value is greater than or equal to the threshold, the output is “1” (TRUE).

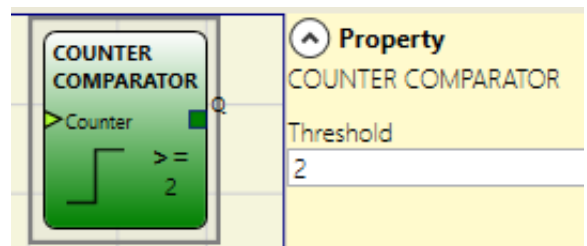

Figure 171: Counter value comparison



Important!

The operator can be connected only to the COUNTER output of a COUNTER operator.

Parameters

Threshold: Counter value from which the output is set to “1” (TRUE)

9.4.5. TIMER operators (max. number = 32 with MSC-CB, max. number = 48 with MSC-CB-S)

Using the operators of type TIMER a signal (TRUE or FALSE) can be generated for a user-defined time.

9.4.5.1. MONOSTABLE

Using the MONOSTABLE operator, an output of "1" (TRUE) is generated by the rising/falling edge of the input. This state is retained for the time set.

Parameters

Time: The delay can be set to a value between 10 ms and 1,098.3 s.

Rising Edge: If selected, the output is set to "1" (TRUE) by a rising edge on the input signal and remains in this state for the time set. However, this state can be extended as long as the input remains at "1" (TRUE).

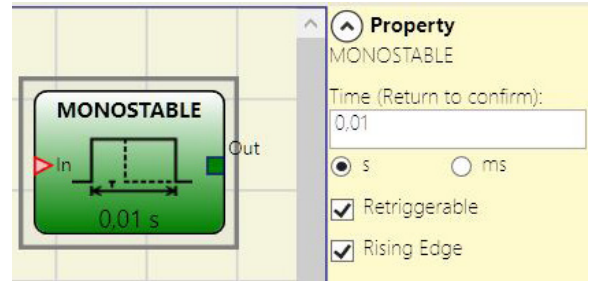

Figure 172: Monostable

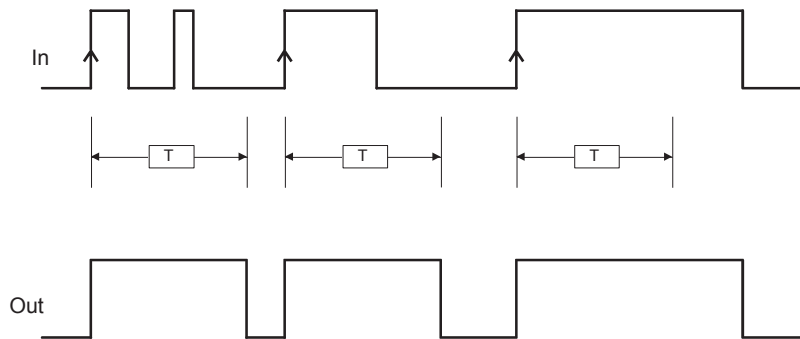

Figure 173: State change on use with rising edge

If not selected, the logic is reversed, i.e. the output is set to "0" (FALSE) by a falling edge on the input signal and remains in this state for the time set. However, this state can be extended as long as the input remains at "0" (FALSE).

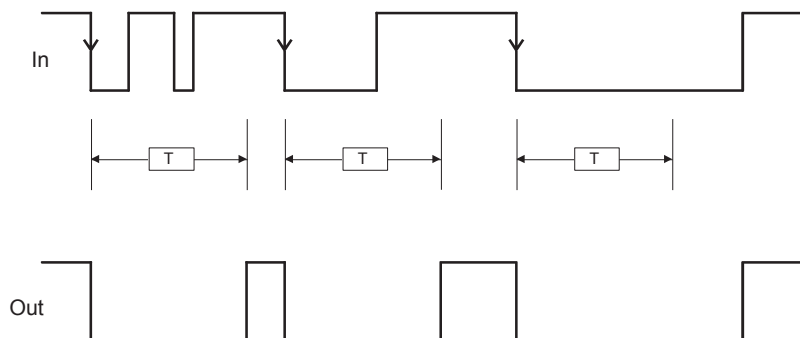

Figure 174: State change on use with falling edge

Retriggerable: If selected, the time is reset on each status change on the input.

9.4.5.2. MONOSTABLE_B

Using this operator, an output of “1” (TRUE) is generated by the rising/falling edge of the input. This state is retained for the time t set.

Parameters

Time: The delay can be set to a value between 10 ms and 1,098.3 s.

Rising Edge: If selected, the output is set to “1” (TRUE) by a rising edge on the input signal and remains in this state for the time set.

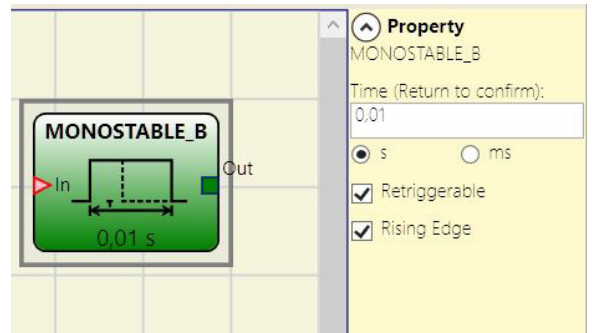

Figure 175: Monostable_B

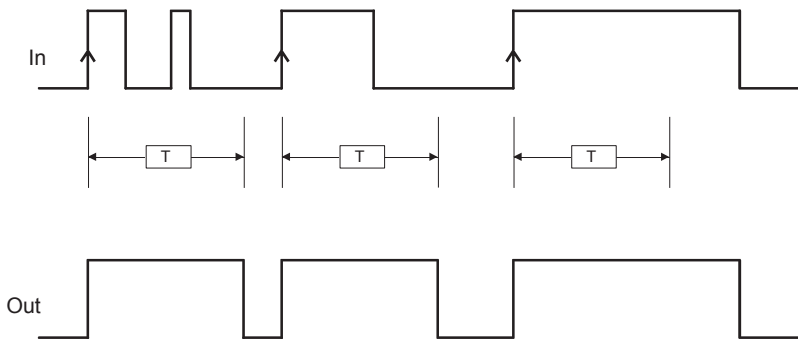

Figure 176: State change on use with rising edge

If not selected, the logic is reversed, i.e. the output is set to “0” (FALSE) by a falling edge on the input signal and remains in this state for the time set.

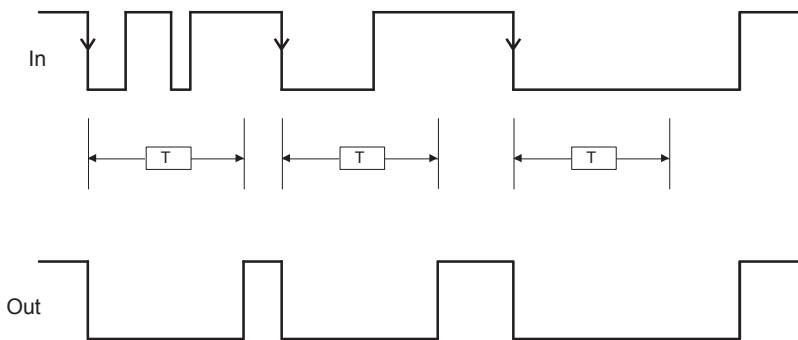

Figure 177: State change on use with falling edge

- ➔ Unlike the MONOSTABLE operator, the OUT output on the MONOSTABLE_B is not kept at “1” (TRUE) beyond the maximum set time t .

Retriggerable: If selected, the time is reset on each status change on the input.

9.4.5.3. Passing make contact (PASSING MAKE CONTACT)

The PASSING MAKE CONTACT operator provides the signal present on the input as a pulse on the output. If this signal is “1” (TRUE) longer than the set time, the pulse is limited to the set time. The pulse is truncated with a falling edge.

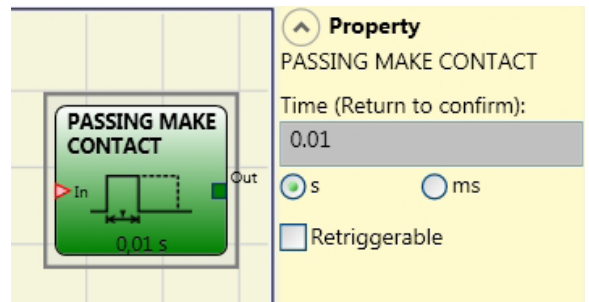

Parameters

Time: The delay can be set to a value between 10 ms and 1,098.3 s. Figure 178: Passing make contact

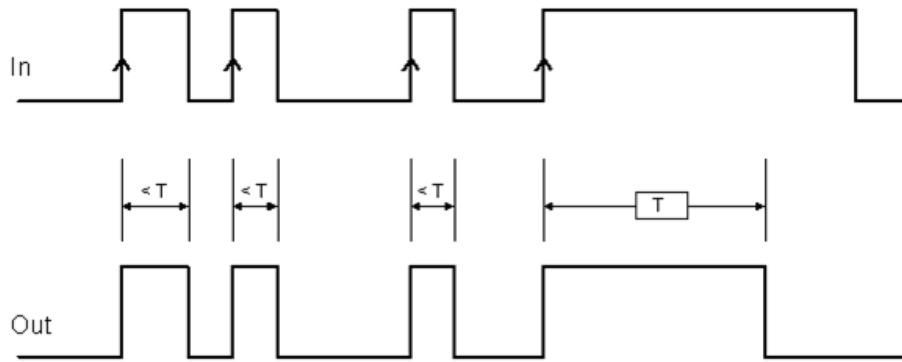

Figure 179: State change of the passing make contact without “Retriggerable” set

Retriggerable: If activated, the time is not reset on a falling input edge. The output remains at “1” (TRUE) for the entire time set. The timer is restarted if there is a new rising edge.

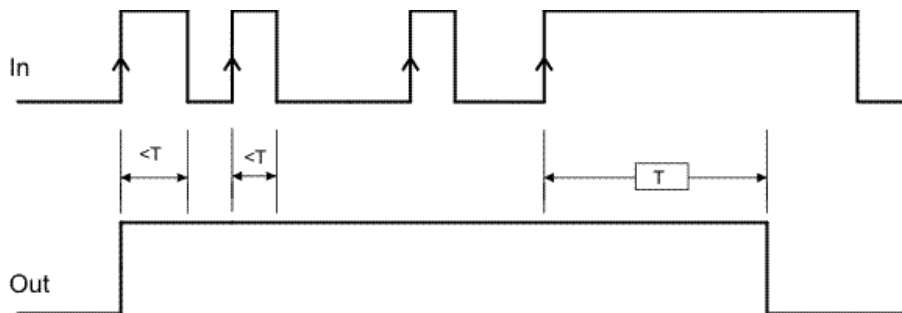

Figure 180: State change of the passing make contact with “Retriggerable”

9.4.5.4. Delay (DELAY)

The DELAY operator makes it possible to use a signal delay and switches the output to “1” (TRUE) after the time set if the status of the signal on the input changes.

Parameters

Time: The delay can be set to a value between 10 ms and 1,098.3 s.

Rising Edge: A switch-on delay is selected with this setting. If selected, the delay starts with the rising edge on the input signal. The output is then set to “1” (TRUE) and remains in this state for the time set, as long as the input remains at “1” (TRUE).

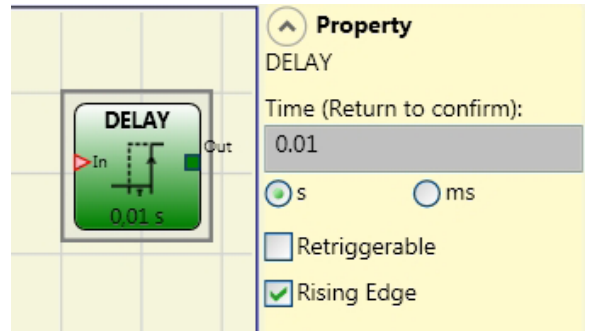

Figure 181: Delay

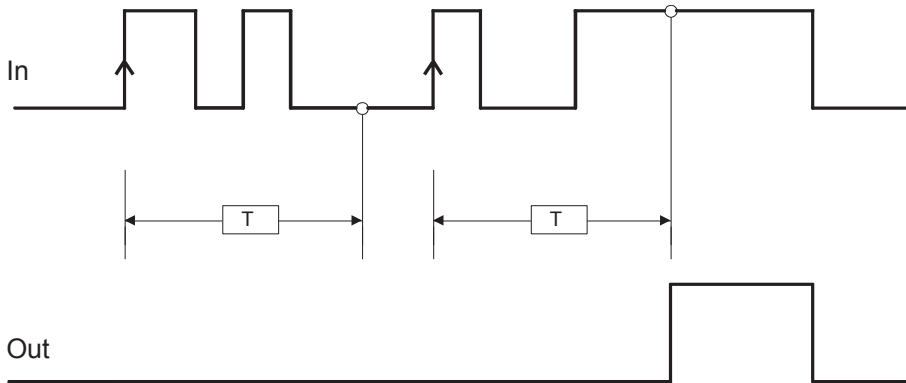

Figure 182: Switch-on delay

If nothing is selected, the logic is reversed. An OFF time is selected with this setting. The output is set to “1” (TRUE) by a rising edge on the input, and the delay starts on the falling edge on the input. At the end of the time set the output is set to “0” (FALSE), provided “0” (FALSE) is present on the input; otherwise it remains at “1” (TRUE).

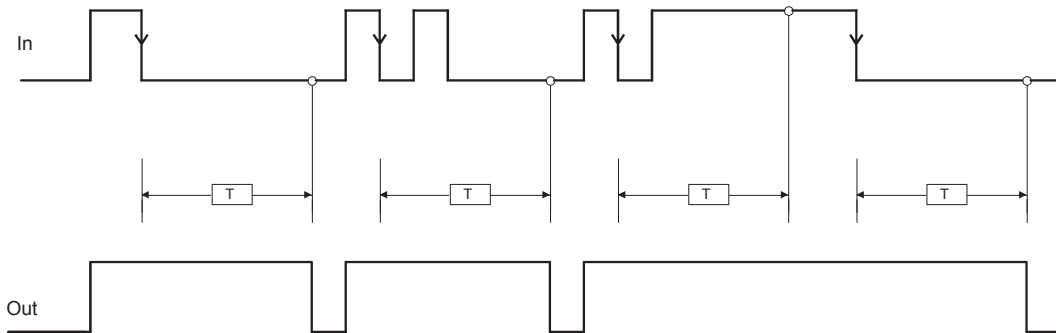
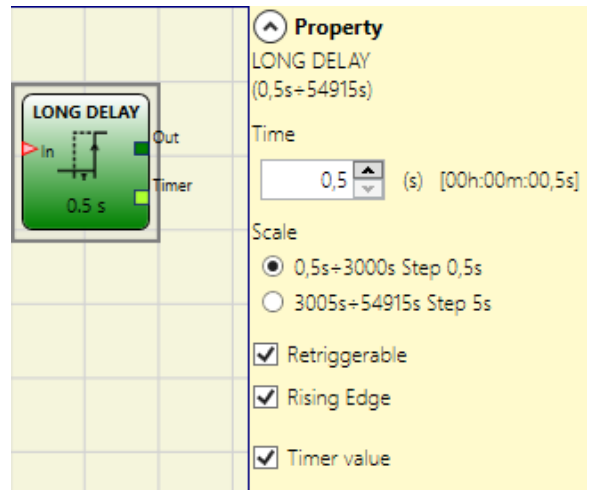

Figure 183: OFF time

Retriggerable: If selected, the delay is reset on each status change on the input.

9.4.5.5. Long-term delay (LONG DELAY) (only MSC-CB-S and MSC-CB ≥ 4.0)

The LONG DELAY operator makes it possible to use a signal delay of up to 15 hours and switches the output to “1” (TRUE) after the time set if the status of the signal at the input changes.



Parameters

Time: The delay can be set to a value between 0.5 s and 54,915 s.

Rising Edge: A switch-on delay is selected with this setting. If selected, the delay starts with the rising edge on the input signal. The output is then set to “1” (TRUE) and remains in this state for the time set, as long as the input remains at “1” (TRUE).

Figure 184: Long-term delay

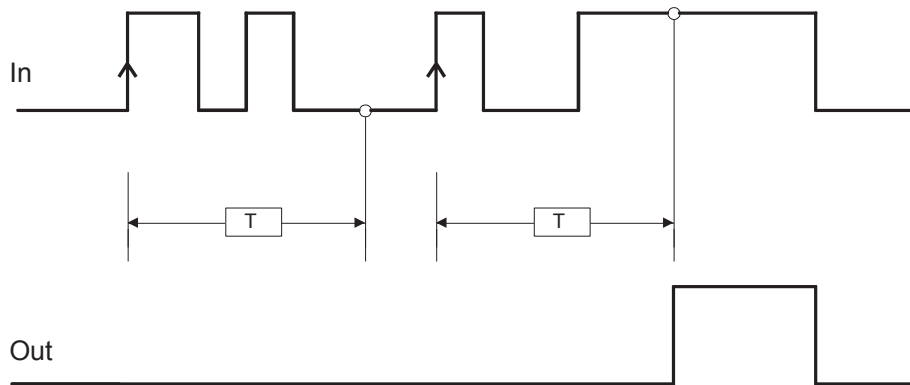

Figure 185: Switch-on delay

If nothing is selected, the logic is reversed. An OFF time is selected with this setting. The output is set to “1” (TRUE) by a rising edge on the input, and the delay starts on the falling edge on the input. At the end of the time set the output is set to “0” (FALSE), provided “0” (FALSE) is present on the input; otherwise it remains at “1” (TRUE).

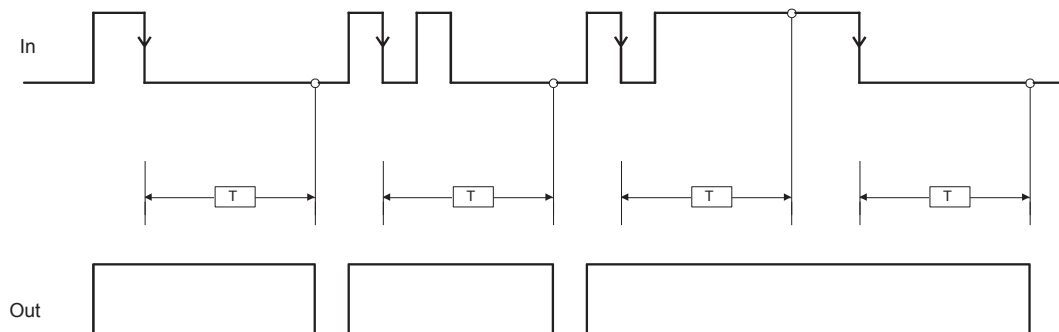

Figure 186: OFF time

Retriggerable: If selected, the delay is reset on each status change on the input.

Timer value: If this is selected, the current value of the timer will be output. This output can be transferred in the input to a DELAY COMPARATOR operator.

9.4.5.6. Timer value comparison (DELAY COMPARATOR) (only MSC-CB-S and MSC-CB ≥ 4.0)

The DELAY COMPARATOR operator enables the Timer output of the Timer operators to be compared with a threshold. If the timer value of the Timer operator is less than the threshold, the output is “0” (FALSE). If the timer value is greater than or equal to the threshold, the output is “1” (TRUE).

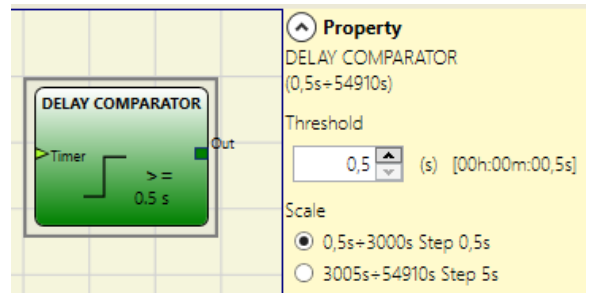

Figure 187: Timer value comparison



Important!

The operator can be connected only to the Timer output of a Timer operator.

Parameters

Threshold: Counter value from which the output is set to “1” (TRUE).

9.4.5.7. Delay line (DELAY LINE)

This operator makes it possible to apply a signal delay and switches the output to “0” after the time set if there is no signal on the input.

If the input returns to “1” before the entered time elapses, the OUT output always produces an LLO (FALSE) pulse. The duration of this pulse corresponds to around twice the response time, and the pulse LLO is delayed by the time set.

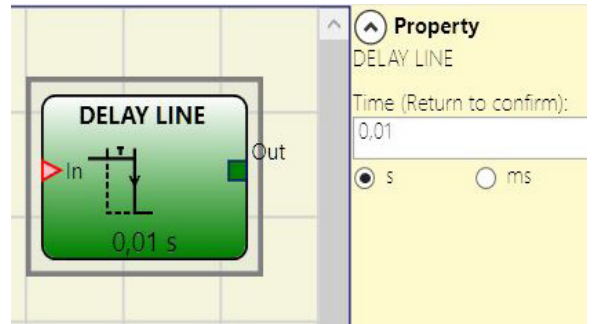

Figure 188: Delay line

Parameters

Time: The delay can be set to a value between 10 ms and 1,098.3 s.

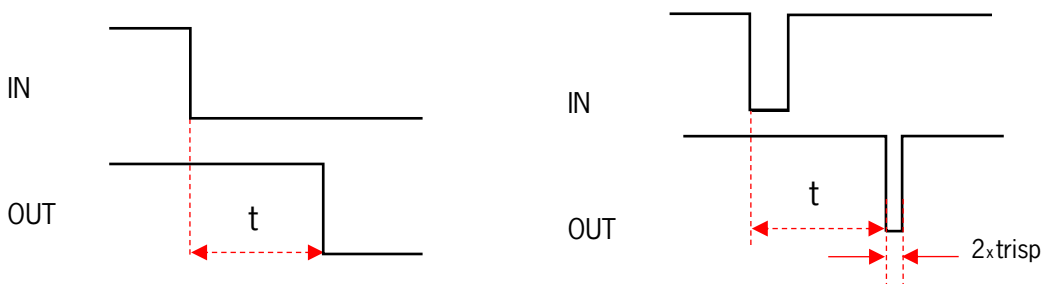

Figure 189: OFF time without filtering short interruptions

- ➔ Unlike the DELAY operator, the DELAY LINE operator does not filter out any interruptions on the input shorter than the time set.
- ➔ This operator is displayed on the use of delayed OSSDs (OSSD must be programmed with RESTART MANUAL).

9.4.5.8. Long-term delay line (LONG DELAY LINE) (only MSC-CB-S and MSC-CB ≥ 4.0)

The operator makes it possible to use a signal delay and switches the output to “0” (FALSE) after a time set (up to 15 hours) if there is no signal at the input. If the input returns to “1” (TRUE) before the entered time elapses, the OUT output always produces an LLO (FALSE) pulse. The duration of this pulse corresponds to around twice the response time, and the pulse LLO is delayed by the time set.

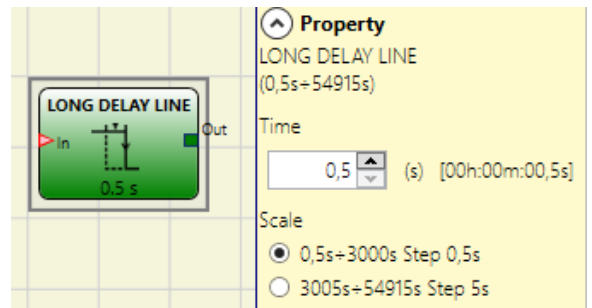

Figure 190: Long-term delay line

Parameters

Time: The delay can be set to a value between 0.5 s and 54,915 s.

- ➔ Unlike the DELAY operator, the DELAY LINE operator does not filter out any interruptions on the input shorter than the time set.
- ➔ This operator is displayed on the use of delayed OSSDs (OSSD must be programmed with RESTART MANUAL).

9.4.5.9. Clock generation (CLOCKING)

Using the CLOCKING operator a clock signal output with the required duration is generated if the input is "1" (TRUE).

Up to 7 inputs are available on the Clocking operator to control the duty cycle on the output.

Parameters

Time: The delay can be set to a value between 10 ms and 1,098.3 s.

Duty cycle choice: Up to 7 inputs for 7 different duty cycles on the output signal can be selected.

The clock signal on OUT has the corresponding duty cycle depending on the input activated.

The EN input must always be set to high (TRUE).

You will find information on how the operator functions in the following table.

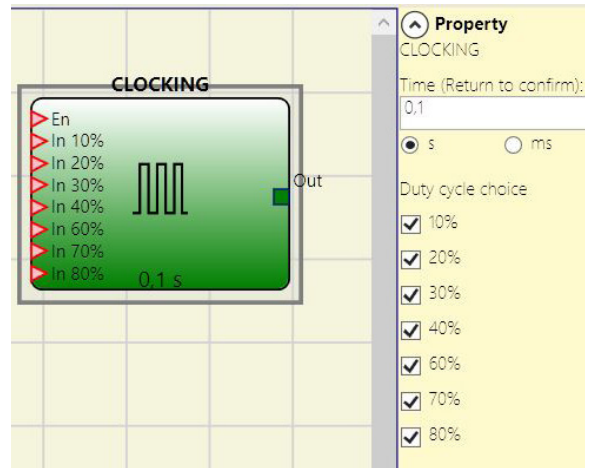

Figure 191: Clock generation

EN	10%	20%	30%	40%	60%	70%	80%	OUT
0	0	0	0	0	0	0	0	0
1	0	0	0	0	0	0	0	50%
1	1	0	0	0	0	0	0	10%
1	0	1	0	0	0	0	0	20%
1	0	0	1	0	0	0	0	30%
1	0	0	0	1	0	0	0	40%
1	0	0	0	0	1	0	0	60%
1	0	0	0	0	0	1	0	70%
1	0	0	0	0	0	0	1	80%
1	1	0	0	0	0	0	1	90%

Table 79: Duty cycle choice

- ➔ The upstream circuit of the CLOCKING operator must ensure that, in addition to the EN release, only one input signal is present (except for duty cycle 10%, 80%).
- ➔ The simultaneous presence of the EN input and a number of inputs > 1 at High level (TRUE) generates an output signal with a duty cycle of 50%.

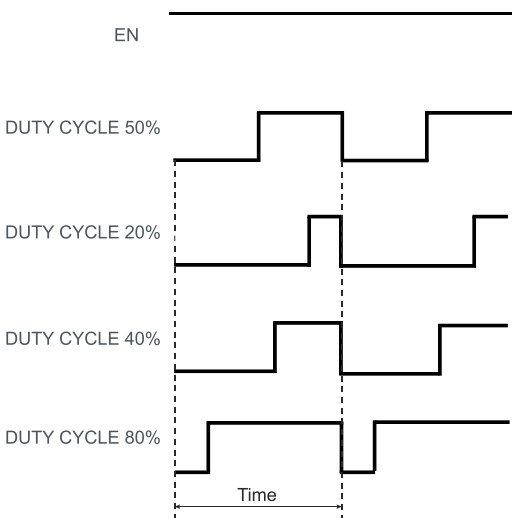

Figure 192: Different duty cycles

9.4.6. The MUTING function

The muting function provides a temporary, automatic interruption of a safety device to enable a normal material flow through a protected opening.

In other words, when the system detects the material and differentiates it from a person (in a potentially hazardous situation), it bypasses the safety device temporarily to permit the material to pass through the opening.

9.4.7. MUTING operators (max. number = 4 with MSC-CB, max. number = 8 with MSC-CB-S)

9.4.7.1. Simultaneous muting (MUTING “Con”)

The muting function is activated after the interruption of the sensors S1 and S2 (the sequence is irrelevant) within the period defined by the operator of between 2 s and 5 s (or S4 and S3 for material that is moving in the opposite direction).

The MUTING “Con” operator with “simultaneous” logic makes it possible to mute the input signal via the sensor inputs S1, S2, S3 and S4.

- ➔ Prerequisite: The muting cycle can start only if all sensors S1 – S4 are “0” (FALSE) and the INPUT input is “1” (TRUE).

Parameters

Timeout (s): Sets the time within which the muting cycle is to be ended from 10 s to infinite. If the cycle is not complete at the end of this time, the muting is interrupted immediately.

With Enable: If selected, it is possible to enable or not enable the muting function. Otherwise, the muting function is always enabled.

There are two enable modes: “Enable/Disable” and “Enable Only.” On the selection of “Enable/Disable” the muting cycle cannot be started if “Enable” is set to “1” (TRUE) or “0” (FALSE). Instead, it is activated only with a rising edge.

To deactivate the muting, set “Enable” to “0” (FALSE). In this mode, the muting is deactivated on a falling edge, irrespective of the state. On the selection of “Enable Only” the muting cannot be deactivated. “Enable” must be set to “0” (FALSE) to enable a new rising edge for the next muting cycle.

Direction: The sequence in which the sensors are activated can be defined. If BIDIR (bidirectional) is set, activation is possible in both directions (from S1&S2 to S3&S4 and from S3&S4 to S1&S2). With UP, activation is possible from S1&S2 to S3&S4, and with DOWN from S3&S4 to S1&S2.

Muting Closing: There are two types: CURTAIN and SENSOR. If CURTAIN is selected, the muting is ended on a rising input signal. With SENSOR the muting is ended when the third sensor has been cleared.

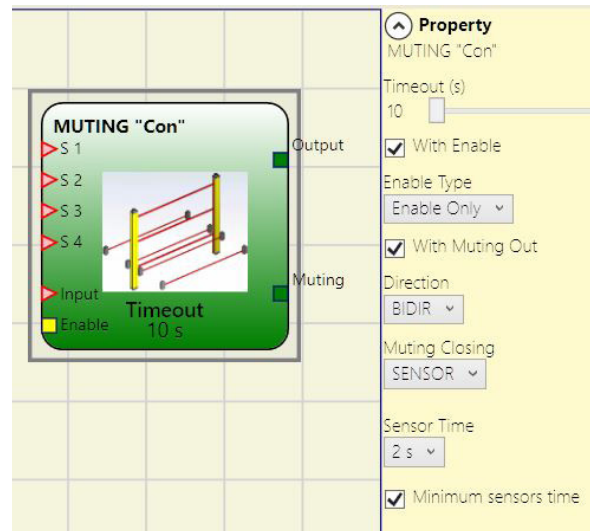

Figure 193: Simultaneous muting

CURTAIN selected					
S1	S2	Input	S3	S4	Muting
0	0	1	0	0	0
1	0	1	0	0	0
1	1	1	0	0	1
1	1	X	0	0	1
1	1	X	1	1	1
0	0	0	1	1	1
0	0	1	1	1	0
0	0	1	0	0	0

Muting activated

Table 80: Status table simultaneous muting with CURTAIN selected

SENSOR selected					
S1	S2	Input	S3	S4	Muting
0	0	1	0	0	0
1	0	1	0	0	0
1	1	1	0	0	1
1	1	X	0	0	1
1	1	X	1	1	1
0	0	0	1	1	1
0	0	1	1	1	1
0	0	1	0	1	0
0	0	1	0	0	0

Muting activated

Table 81: Status table simultaneous muting with SENSOR selected

Blind Time: Only with “Muting Closing = Curtain”: Should be selected if, for instance, it is known that after the end of the muting, objects may protrude beyond the pallet and may occupy the light grid, as a result the INPUT input is set to “0” (FALSE). During the blind time the INPUT input remains “1” (TRUE). The blind time can be between 250 ms and 1 s.

Sensor Time: The **maximum time** (between 2 s and 5 s) between the activation of two muting sensors can be set.

Minimum sensors time: If selected, muting can be activated only if a time **>150 ms** has elapsed between the activation of sensor 1 and sensor 2 (or sensor 4 and sensor 3).

9.4.7.2. MUTING "L"

The muting function is activated after the interruption of the sensors S1 and S2 (the sequence is irrelevant) within the period defined by the operator of between 2 s and 5 s.

The muting status ends after the opening has been cleared.

The MUTING operator with "L" logic makes it possible to mute the input signal via the sensor inputs S1 and S2.

- ➔ Prerequisite: The muting cycle can start only if S1 and S2 are "0" (FALSE) and the input is "1" (TRUE).

Parameters

Timeout (s): Sets the time within which the muting cycle is to be ended from 10 s to infinite. If the cycle is not complete at the end of this time, the muting is interrupted immediately.

With Enable: If selected, it is possible to enable or not enable the muting function. Otherwise, the muting function is always enabled.

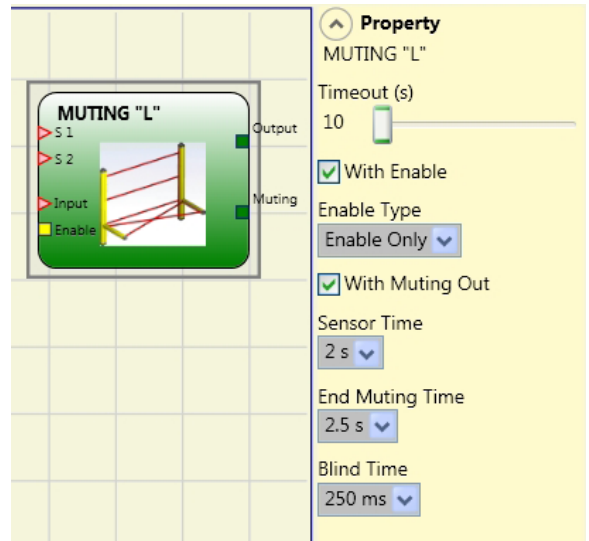

Figure 194: L muting

There are two enable modes: "Enable/Disable" and "Enable Only." On the selection of "Enable/Disable" the muting cycle cannot be started if "Enable" is set to "1" (TRUE) or "0" (FALSE). Instead, it is activated only with a rising edge. To deactivate the muting, set "Enable" to "0" (FALSE). In this mode, the muting is deactivated on a falling edge, irrespective of the state. On the selection of "Enable Only" the muting cannot be deactivated. "Enable" must be set to "0" (FALSE) to enable a new rising edge for the next muting cycle.

Sensor Time: The **maximum time** (between 2 s and 5 s) between the activation of two muting sensors can be set.

End Muting Time: Specification of the **maximum time** (between 2.5 and 6 s) that must elapse between enabling of the first sensor and enabling of the hazardous opening.

After this time has elapsed, the muting function is at an end.

Blind Time: Should be selected if, for instance, it is known that after the end of the muting, objects may protrude beyond the pallet and may occupy the light grid and thereby set the INPUT input to "0" (FALSE). During the blind time the input remains "1" (TRUE). The blind time can be between 250 ms and 1 s.

9.4.7.3. “Sequential” MUTING

The muting function is activated after the sequential interruption of the sensors S1 and S2, followed by sensors S3 and S4 (without any time limit). If the pallet moves in the opposite direction, the correct sequence is: S4, S3, S2, S1.

The MUTING operator with “sequential” logic makes it possible to mute the input signal via the sensor inputs S1, S2, S3 and S4.

- ➔ Prerequisite: The muting cycle can start only if all sensors S1 – S4 are “0” (FALSE) and the INPUT input is “1” (TRUE).

Parameters

Timeout (s): Sets the time within which the muting cycle is to be ended from 10 s to infinite. If the cycle is not complete at the end of this time, the muting is interrupted immediately.

With Enable: If selected, it is possible to enable or not enable the muting function. Otherwise, the muting function is always enabled.

There are two enable modes: “Enable/Disable” and “Enable Only.” On the selection of “Enable/Disable” the muting cycle cannot be started if “Enable” is set to “1” (TRUE) or “0” (FALSE). Instead, it is activated only with a rising edge. To deactivate the muting, set “Enable” to “0” (FALSE). In this mode, the muting is deactivated on a falling edge, irrespective of the state. On the selection of “Enable Only” the muting cannot be deactivated. “Enable” must be set to “0” (FALSE) to enable a new rising edge for the next muting cycle.

Direction: The sequence in which the sensors are activated can be defined. If BIDIRECTIONAL is set, activation is possible in both directions (from S1 to S4 and from S4 to S1). With UP, activation is possible from S1 to S4 and with DOWN, from S4 to S1.

Muting Closing: There are two types: CURTAIN and SENSOR. If CURTAIN is selected, the muting is ended on a rising input signal. With SENSOR the muting is ended when the penultimate sensor has been cleared.

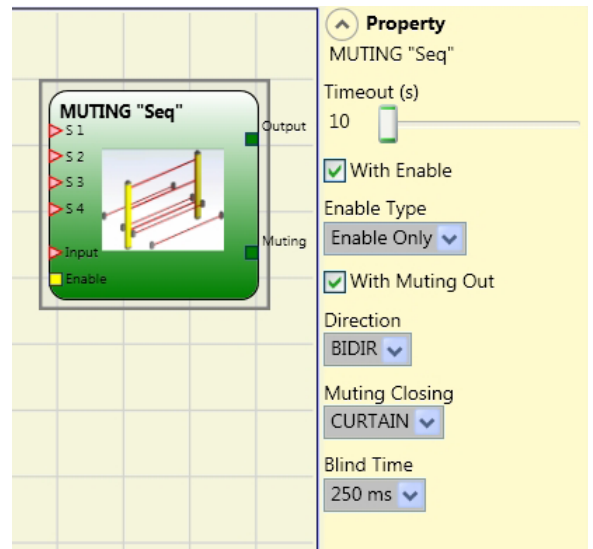

Figure 195: “Sequential” MUTING

CURTAIN selected					
S1	S2	Input	S3	S4	Muting
0	0	1	0	0	0
1	0	1	0	0	0
1	1	1	0	0	1
1	1	X	0	0	1
1	1	X	1	0	1
1	1	X	1	1	1
0	1	X	1	1	1
0	0	0	1	1	1
0	0	1	1	1	0
0	0	1	0	1	0
0	0	1	0	0	0

Muting activated

Table 82: Status table sequential muting with CURTAIN selected

SENSOR selected					
S1	S2	Input	S3	S4	Muting
0	0	1	0	0	0
1	0	1	0	0	0
1	1	1	0	0	1
1	1	X	0	0	1
1	1	X	1	0	1
1	1	X	1	1	1
0	1	X	1	1	1
0	0	0	1	1	1
0	0	1	1	1	1
0	0	1	0	1	0
0	0	1	0	0	0

Muting activated

Table 83: Status table sequential muting with SENSOR selected

Blind Time: Only with "Muting Closing = Curtain": Should be selected if, for instance, it is known that after the end of the muting, objects may protrude beyond the pallet and may occupy the light grid, as a result the INPUT input is set to "0" (FALSE). During the blind time the input remains "1" (TRUE). The blind time can be between 250 ms and 1 s.

9.4.7.4. MUTING "T"

The muting function is activated after the interruption of the sensors S1 and S2 (the sequence is irrelevant) within the period defined by the operator of between 2 s and 5 s.

The muting status ends after both sensors have been cleared.

The MUTING operator with "T" logic makes it possible to mute the INPUT input signal via the sensor inputs S1 and S2.

- ➔ Prerequisite: The muting cycle can start only if S1 and S2 are "0" (FALSE) and the input is "1" (TRUE).

Parameters

Timeout (s): Sets the time within which the muting cycle is to be ended from 10 s to infinite. If the cycle is not complete at the end of this time, the muting is interrupted immediately.

With Enable: If selected, it is possible to enable or not enable the muting function. Otherwise, the muting function is always enabled.

There are two enable modes: "Enable/Disable" and "Enable Only." On the selection of "Enable/Disable" the muting cycle cannot be started if "Enable" is set to "1" (TRUE) or "0" (FALSE). Instead, it is activated only with a rising edge. To deactivate the muting, set "Enable" to "0" (FALSE). In this mode, the muting is deactivated on a falling edge, irrespective of the state. On the selection of "Enable Only" the muting cannot be deactivated. "Enable" must be set to "0" (FALSE) to enable a new rising edge for the next muting cycle.

Sensor Time: The **maximum time** (between 2 s and 5 s) between the activation of two muting sensors can be set.

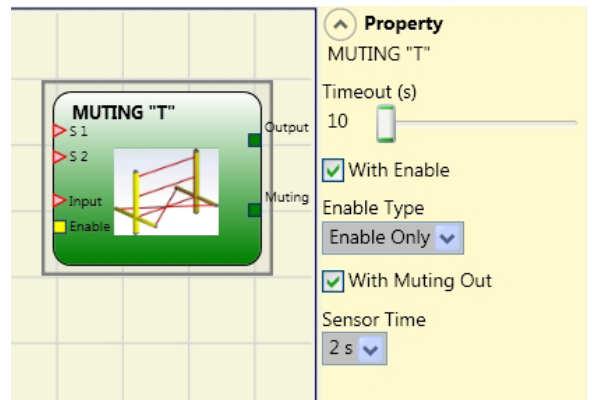

Figure 196: T muting

9.4.7.5. MUTING OVERRIDE

The OVERRIDE function is necessary if the machine stops after erroneous sequences of the muting activation and material is occupying the hazardous opening.

This process activates the OUTPUT output and in this way makes it possible to remove the material that is blocking the opening.

The Muting Override operator must be connected after the Muting operator ("T," "L," "SEQ," "Con") (OUTPUT output on the MUTING ("T," "L," "SEQ," "Con") connected directly to the INPUT input on the Muting Override).

The operator make it possible to override the directly connected muting input.

The "Override" operator can be activated only if muting is not active (INPUT = "0") and at least one muting sensor (or the light grid) is occupied.

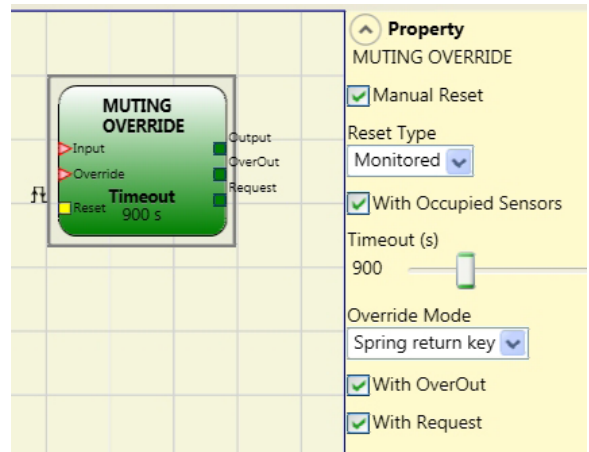

Figure 197: Muting override

The override function ends as soon as the light grid and the muting sensors are clear again. The OUTPUT output switches to logical "0" (FALSE).

The override function can be started either by state control or edge control.

Start of the override with state: This function is used if the override command (OVERRIDE = 1) is to be active during all subsequent processes. However, a further override function can be activated only if the command is deactivated and is then activated again.

If the light grid and the sensors are cleared (not occupied) or if the time is exceeded, the override is ended without the need for further commands.

Start of the override with edge: The override function is activated by the rising edge on the Override input (OVERRIDE = 1).

The override function is ended if the light grid and the sensors are cleared (not occupied) or on timeout.

The override function can be restarted only if the override enable is activated again (OVERRIDE = 1).

Parameters

i	<p>NOTICE</p> <p><i>With Occupied Sensors:</i> Must be selected for sequential muting, "T" muting and simultaneous muting. With "L" muting, this option is not allowed to be selected.</p> <ul style="list-style-type: none"> ➔ Otherwise, a warning will be output during the compiler phase and in the report. ➔ The user must take additional safety measures while the override is active.
----------	---

Conditions to be checked on activating the override function					
"With Occupied Sensors" selected	Sensor occupied	Light grid occupied	Input	Override	Output
X	X	–	0	1	1
–	–	X	0	1	1
	X	–	0	1	1
	X	X	0	1	1

Table 84: Status table on use of the override function

Timeout (s): Permits the setting of the time within which the override function must be ended from 10 s to infinite.

Override Mode: Makes it possible to configure the start of the override function (pulsed or state triggered).

With OverOut: Makes it possible to activate an active override signal output (active if High).

With Request: Makes it possible to activate a signal output (active if High) to indicate that the override function can be activated.

Manual Reset:

- › If the RESET input is active (TRUE), the OUTPUT output of the function block is enabled.
- › If the RESET input is not active (FALSE), the OUTPUT output of the function block follows the override request.

There are two types of reset: "Manual" and "Monitored." On the selection of manual reset, the system checks only the signal transition from 0 to 1. With monitored reset, the double transition from 0 to 1 and then back to 0 is checked.

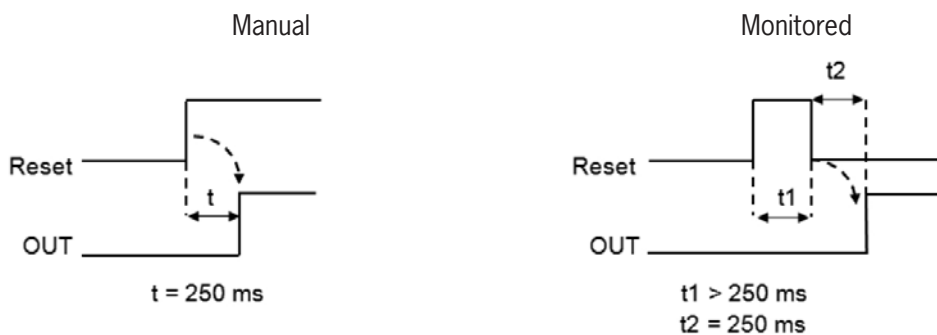

Figure 198: Muting override reset

9.5. Other function blocks

9.5.1. Serial output (SERIAL OUTPUT) (max. number = 4)

Using the SERIAL OUTPUT operator the status of up to 8 sensors is output; the data are output in series.

Principle of operation

Using this operator the status of all inputs connected is output in two different ways:

Asynchronous serial output:

1. The status on the cable when not in use is "1" (TRUE).
2. The start data transfer signal is 1 bit = "0" (FALSE).
3. Transfer of n bits, where the status of the inputs connected is *Manchester coded*:
 - Status 0: rising signal edge in the middle of the bit
 - Status 1: falling signal edge in the middle of the bit
4. Intercharacter interval is "1" (TRUE) to make it possible to synchronize an external device.

For this reason the Clock output is not available with the asynchronous method.

Synchronous serial output:

1. Output and Clock are "0" (FALSE) when not in use.
2. Transfer of n bits, where the input status is coded with OUTPUT as data and CLOCK as timebase.
3. Intercharacter interval is "0" (FALSE) to make it possible to synchronize an external device.

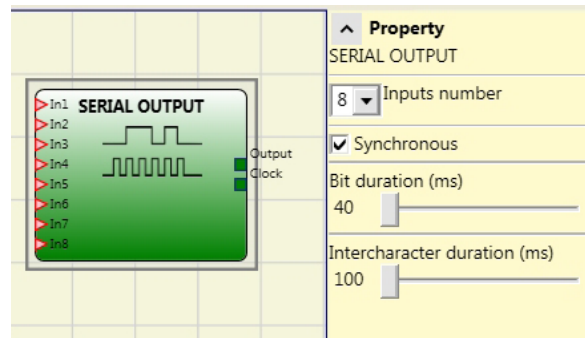

Figure 199: Serial output

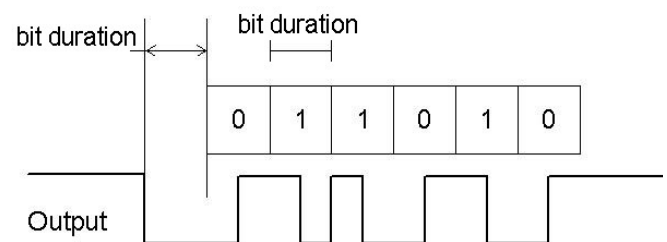

Figure 200: Asynchronous serial output

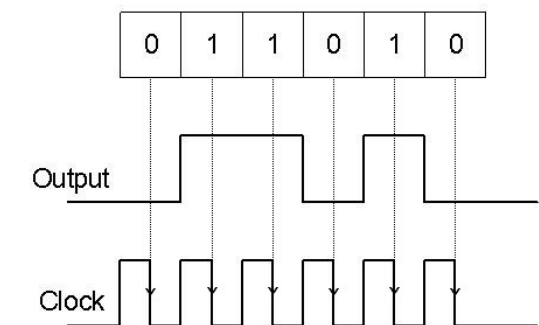

Figure 201: Synchronous serial output

Parameters

Inputs number: Defines the number of inputs of the function block. These can be 2 to 8 (asynchronous) or 3 to 8 (synchronous).

Mode selection: Choice between synchronous and asynchronous serialization

Bit duration (ms): In this field, you can enter the value that corresponds to the duration of the individual bits (input n) in the pulse sequence that comprises the transmission.

- 40 ms – 200 ms (10 ms step)
- 250 ms – 0.95 s (50 ms step)

Intercharacter duration (ms): Enter in this field the time that must elapse between the transmission of one pulse sequence and the next.

- 100 ms – 2.5 s (100 ms step)
- 3 s – 6 s (500 ms step)

9.5.2. OSSD EDM (only MSC-CB-S) (max. number = 32)

The OSSD EDM block enables any input to be used for feedback loop monitoring of a safety output. The OUTPUT output can be connected only with a safety output (OSSD, Single OSSD, relay). To enable this block to be used, the “external delay time K” function must be deactivated for the safety output.

If the In input is at “1” (TRUE), the FBK_K signal must be at “0” (FALSE) and must then change to “1” (TRUE) within the specified time. If the FBK_K signal does not change within the specified time, the OUTPUT output will be set to “0” and the corresponding CLEAR LED on the MSC will flash to indicate the error. The ERROR OUT output is also set to “1” (TRUE).

If the error signal is activated for the safety output, the error signal is set to “1” (TRUE) if an error was detected in the external feedback loop:

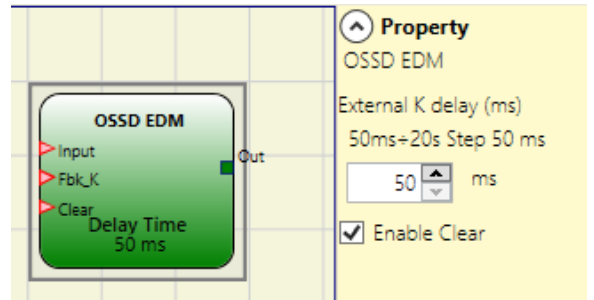

Figure 202: OSSD EDM

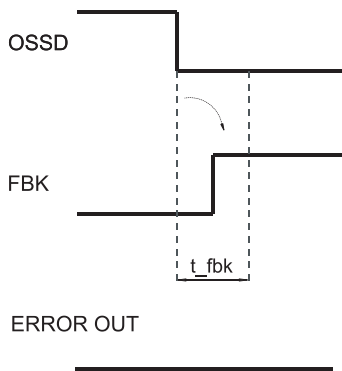

Figure 203: Example for OSSD with correct feedback signal: in this case ERROR OUT=FALSE

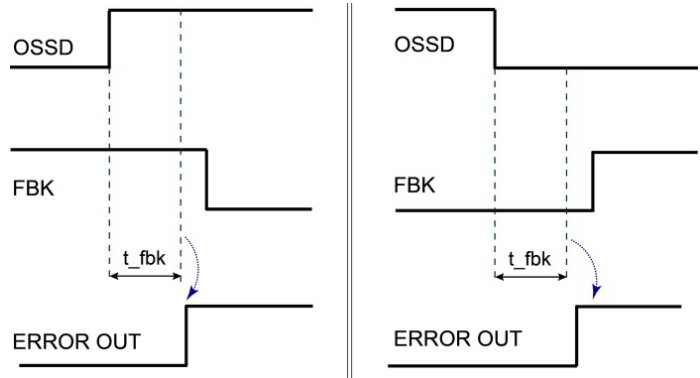

Figure 204: Example for OSSD with erroneous feedback signal (external switching time exceeded): In this case, ERROR OUT=TRUE

Parameters

External K delay (ms): Time window for monitoring the external feedback signal (on the state of the output).

Enable Clear: If activated, the error can be cleared without having to restart the MSC.

9.5.3. TERMINATOR

The TERMINATOR operator makes it possible to add an input that is not used in the program.

The input connected with the TERMINATOR appears in the input structure, and its status is sent via the bus.

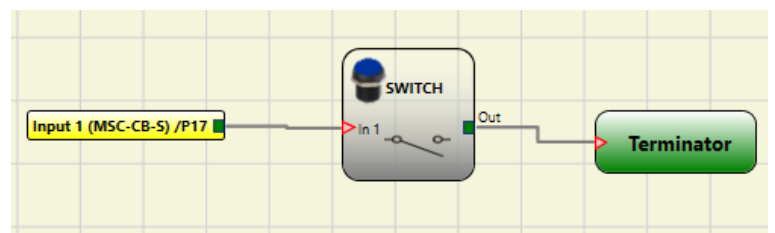

Figure 205: TERMINATOR

9.5.4. Network (NETWORK) (max. number = 1)

Using the NETWORK operator, STOP and RESET commands are distributed via a local network. Using **Network_IN** and **Network_OUT** it is possible to exchange START, STOP and RUN signals between the various nodes.

Principle of operation

Using this operator you can straightforwardly distribute STOP and RESET commands via a local MSC network.

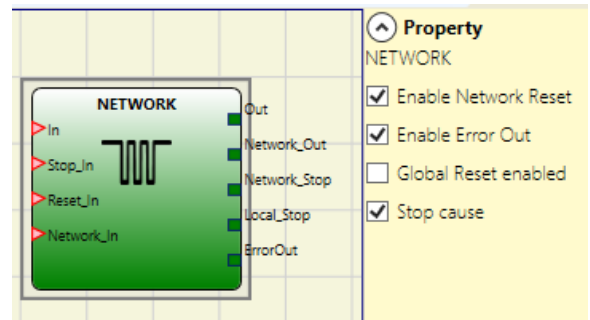

Figure 206: Network

The following conditions must be met for the “Network” operator:

1. The input connected to a single or double *Network_In* input must be connected to the **Network_OUT** output on the previous module in the network.
2. The **Network_OUT** output connected to a STATUS output or an OSSD output must be connected to the **Network_IN** input on the following module in the local network.
3. The **Stop_IN** and **Reset_IN** inputs must be connected to input devices that act as stop (e.g. E-STOP) or reset devices (e.g. SWITCH).
4. The **IN** input can be connected as required to the logic (e.g. input function blocks or results of logical combinations).
5. The **Output** output can be connected in the logic as required. The output is “1” (TRUE) if the IN input is “1” (TRUE) and the function block has been restarted.

Parameters

Enable Network Reset: If activated, the function block can be reset via the network. If not selected, the function block can be reset only via the local **Reset_IN** input.

Enable Error Out: If activated, the STATUS output **Error_OUT** is available.

Global Activation Reset: If activated, the entire system can be restarted with a reset button from any node in the network. If this is not activated, all nodes can be restarted except for the node that caused the stop (this node must be restarted using a separate reset).

Stop cause: If activated, the NETWORK_STOP and LOCAL_STOP outputs will be activated and indicate the cause for the STOP status. These outputs are normally “0” (FALSE) when the system is in RUN mode and OUTPUT is at “1” (TRUE). If a stop is requested from the network, the NETWORK_STOP output changes to “1” (TRUE). If the OUTPUT output changes to “0” (FALSE) due to the IN and STOP_IN inputs, the LOCAL_STOP output becomes “1” (TRUE). The outputs stay under these conditions until the next network reset.



WARNING

The RESET command switches must be installed outside the danger zones for the network in places at which there is a clear view of the entire work areas affected.



NOTICE

- › A maximum of 10 base units can be connected in the network configuration.
- › A maximum of 9 extension modules can be connected to each base unit.

Application example:

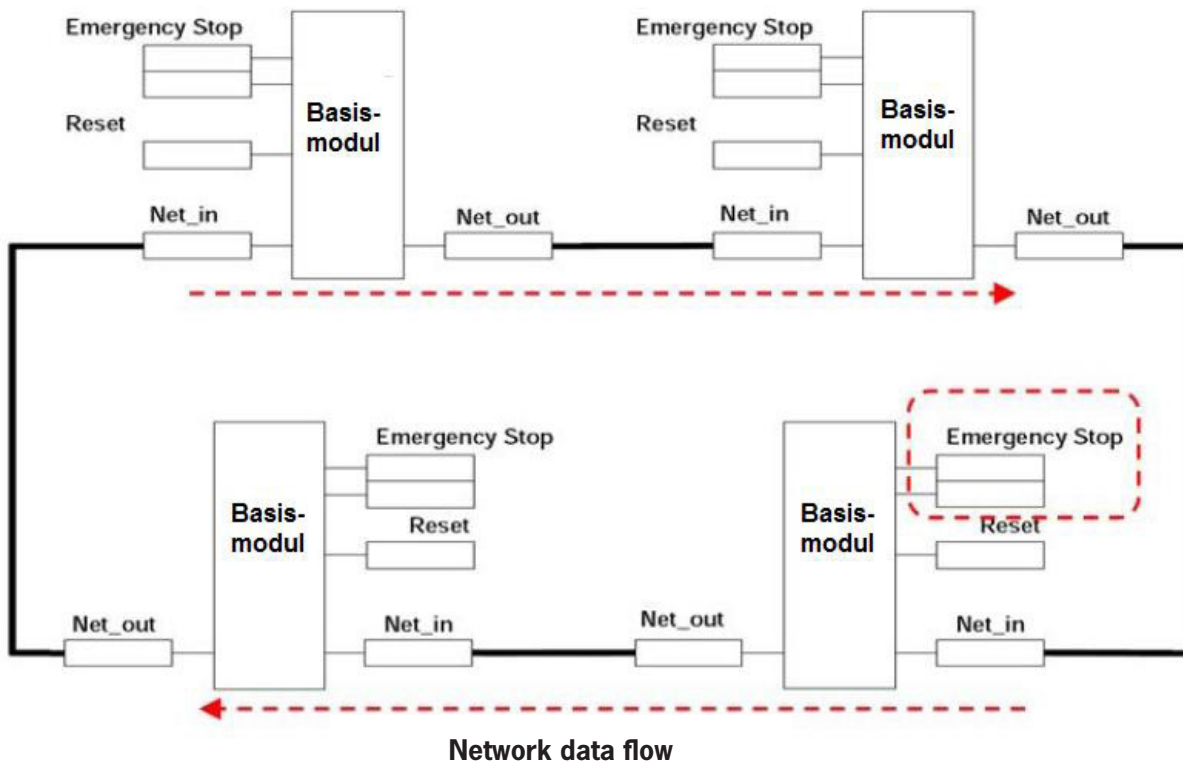

Figure 207: Application example, network

Condition 1: During switch-on, see Figure 207:

The OUTPUTS on the various nodes are in the state "0" (FALSE).

2. The STOP signal is sent via the **Network_OUT** cable.
3. If the RESET command switch on a node is actuated, all existing nodes are started when the START signal is sent.
4. As the final result, the OUTPUT on all nodes connected has the state "1" (TRUE) if the various inputs (IN) have the state "1" (TRUE).
5. The RUN signal is transmitted via the network to the four existing nodes.

Condition 2: If the emergency stop button is pressed on one of the four nodes, see Figure 207:

The OUTPUT changes to the state "0" (FALSE).

2. The STOP signal is sent via the Network_OUT cable.
3. The next node receives the STOP code and deactivates the output.
4. The STOP command generates the STOP code for all lines of type Network_IN and Network_OUT.
5. As the final result **the OUTPUT on all nodes connected is in the state "0" (FALSE).**
6. If the emergency stop is switched back to the normal position, all nodes can be restarted with a single reset by transmitting the START signal again. The latter condition does not occur if ENABLE RESET NETWORK is not selected. In this event, the local reset method must be used. **The system needs approx. 4 seconds to restore all outputs on the blocks that form the network.**



Important!

Perform a local reset of the module that caused the loss of the power supply to restore the safety output.

Response time: The maximum response time of the network starting with the triggering of the emergency stop is determined using the following formula: $t_r = (212 \text{ ms} * n^{\circ} \text{Master}) - 260 \text{ ms}$

➔ The maximum number of base units connected must not be more than 10.

Example of a network with 4 nodes:

	MASTER 1	MASTER 2	MASTER 3	MASTER 4
Actuation of emergency stop	$t_r \text{ MASTER 1}$	$t_r \text{ MASTER 2}$	$t_r \text{ MASTER 3}$	$t_r \text{ MASTER 4}$
	12.6 ms	164 ms	376 ms	488 ms

Table 85: Response time of a network with 4 nodes

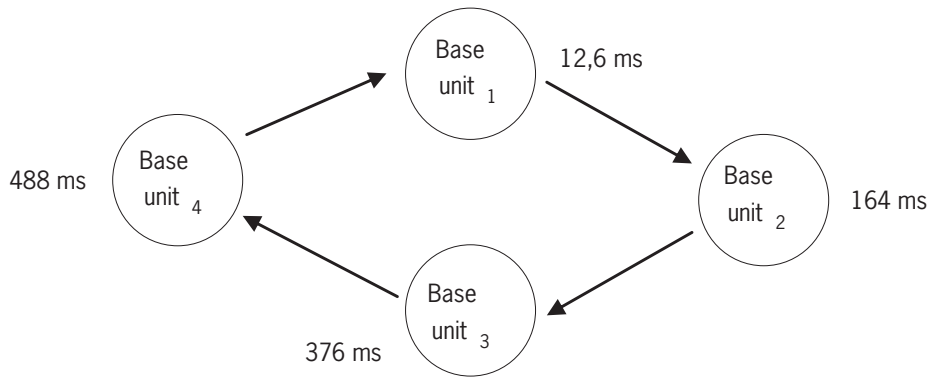

Figure 208: Response time of the network

Condition 3: If the IN input on the network function block on one of the 4 nodes switches to the state “0” (FALSE), see Figure 207

1. The local output changes to the state “0” (FALSE).
2. The RUN signal continues to be sent via the Network_OUT lines.
3. The states of the other nodes remain unchanged.
4. In this event, the local reset method must be used. The Reset_in LED flashes to indicate this state. The related node can be restarted using its reset.

The Reset_In and **Network_IN** inputs and the **Network_OUT** output can be represented only on the I/O terminals of the base unit.

	Network IN			Network OUT (OSSD)	Network OUT (STATUS)	Reset in
	LED	FAIL EXT	IN (1)	OSSD (2)	STATUS	IN (3)
STATE	STOP	OFF	OFF	RED	OFF	OFF
	CLEAR	OFF	FLASHING	RED/GREEN (FLASHING)	FLASHING	FLASHING
	RUN	OFF	ON	GREEN	ON	ON
	FAIL	ON	FLASHING	–	–	–

- (1) Corresponds to the input that is connected to Network IN.
- (2) Corresponds to the input that is connected to Network OUT.
- (3) Corresponds to the input that is connected to Reset IN.

Table 86: Signals of the “NETWORK” function block

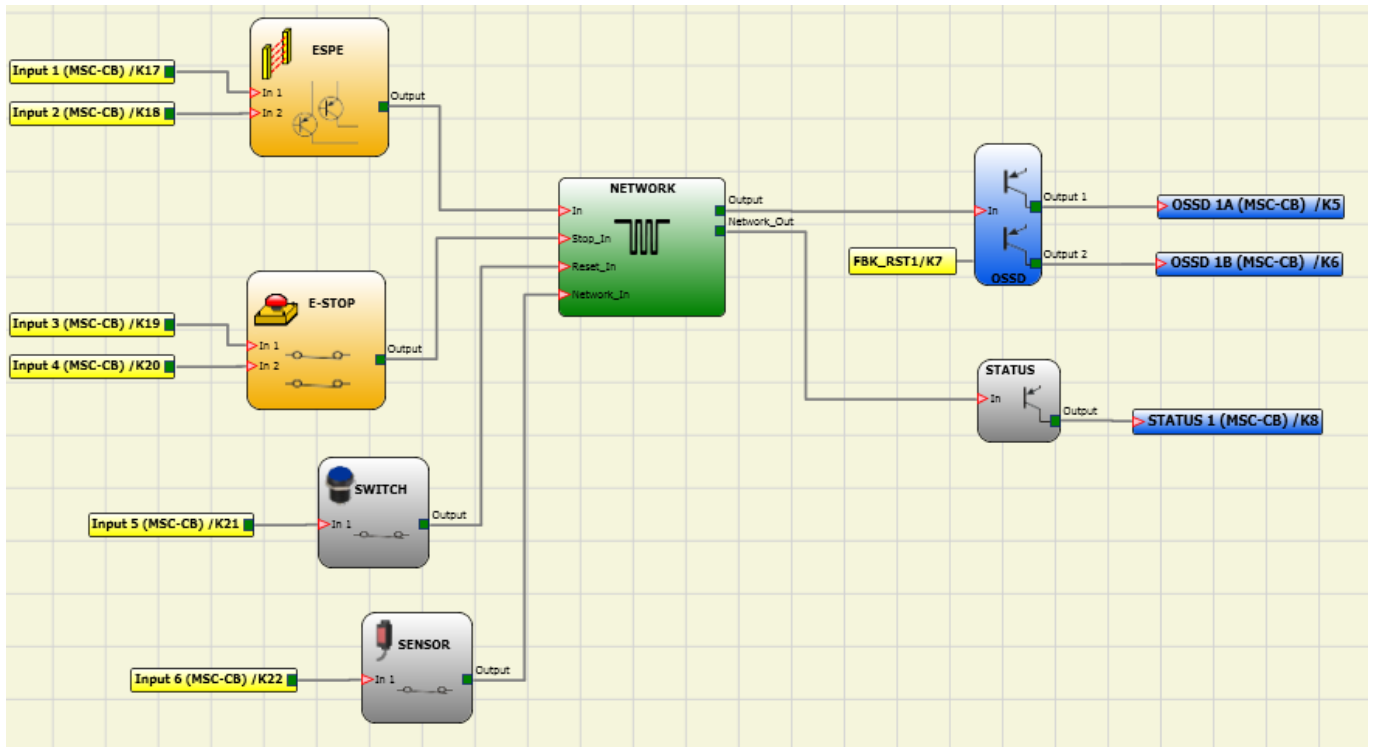

Figure 209: Application example for the NETWORK function block (category 2)

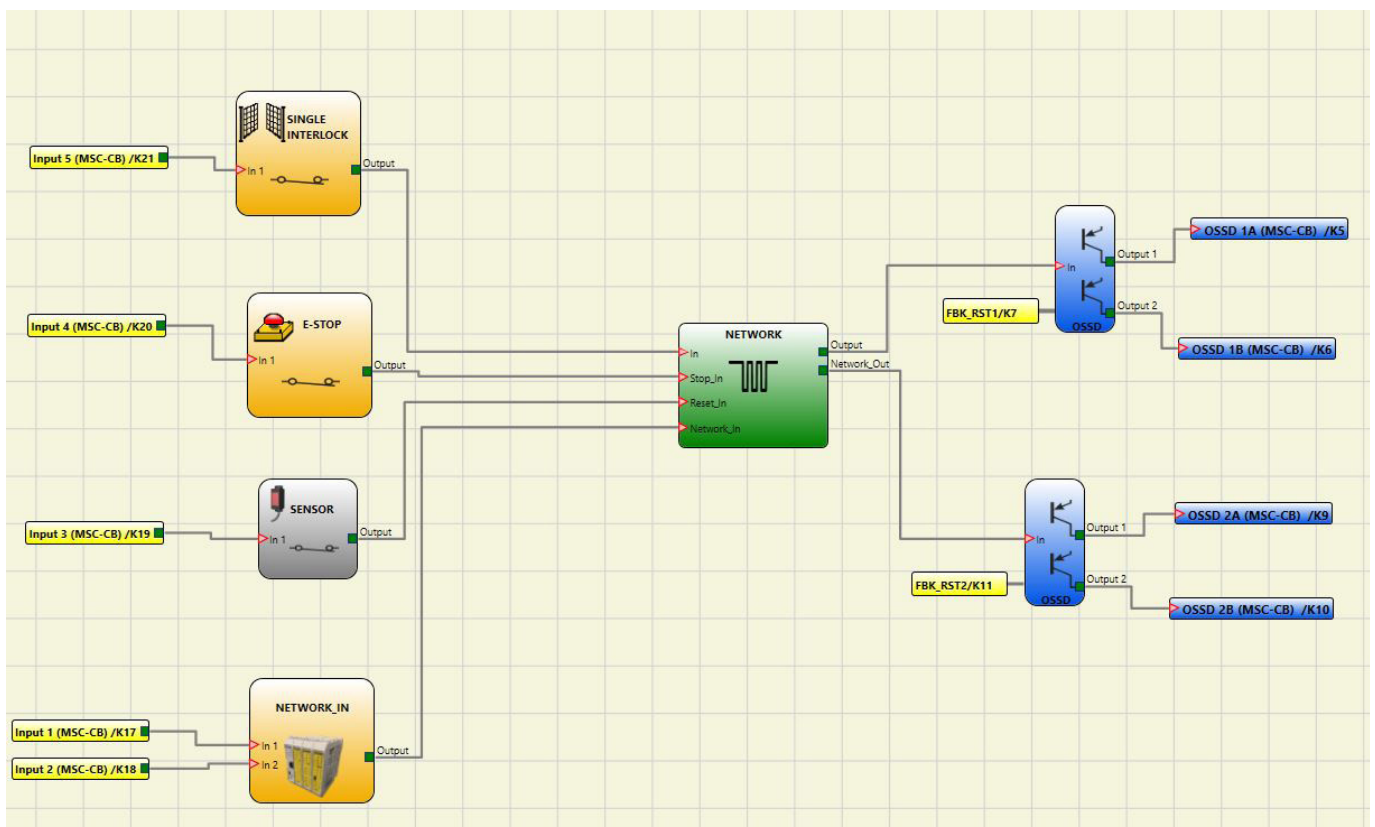

Figure 210: Application example for the NETWORK function block (category 4)

9.5.5. Reset (RESET)

This operator generates a system reset if there is an OFF-ON-OFF transition with a duration of less than 5 s on the corresponding input.

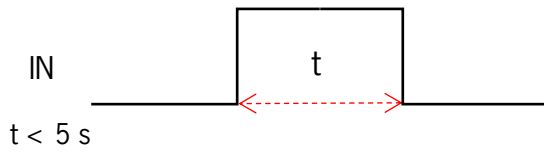

Figure 211: Reset duration



Figure 212: Reset



NOTICE

- › If the duration is $> 5 \text{ s}$, there is no reset.
- › Reset (RESET) can be used to reset malfunctions without interrupting the power supply to the system.

9.5.6. Interpage In/Out

If the circuit diagram is very comprehensive and a connection between two elements that are a long way apart is necessary, the component “Interpage In/Out” can be used.

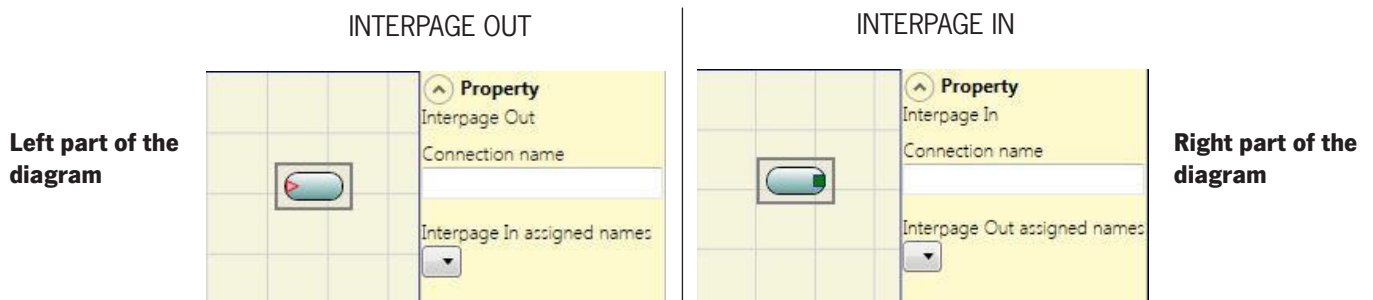

Figure 213: Interpage In/Out

In order to establish a connection, “Connection: input” and “Connection: output” must have the same name.

9.5.7. Input/output for internal feedback (max. number = 8, only MSC-CB-S ≥ 6.0)

The IntFbk In/Out operators can be used to create logical loops or to connect the output of a function block with the input of another function block.

After a logic cycle delay of the base unit, each IntFbk_In assumes the same logic value of the corresponding IntFbk_Out.

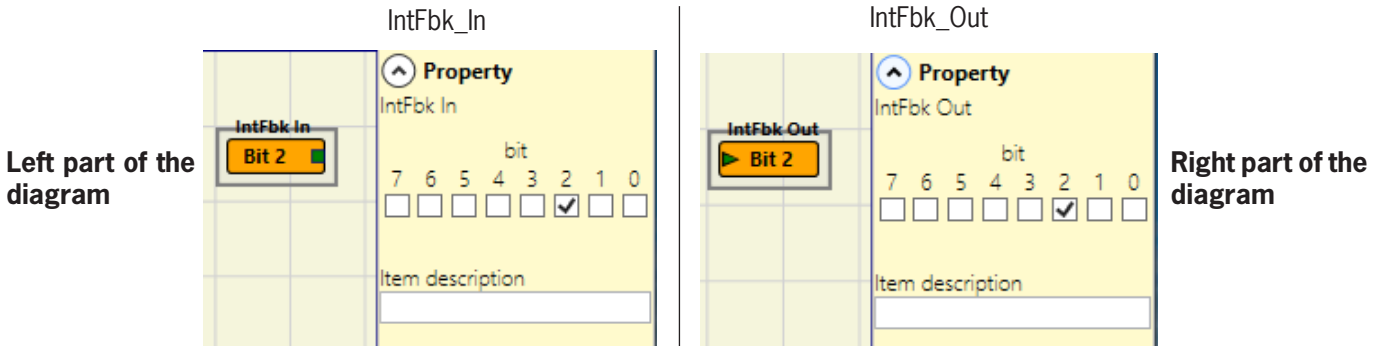

Figure 214: Input/output for internal feedback

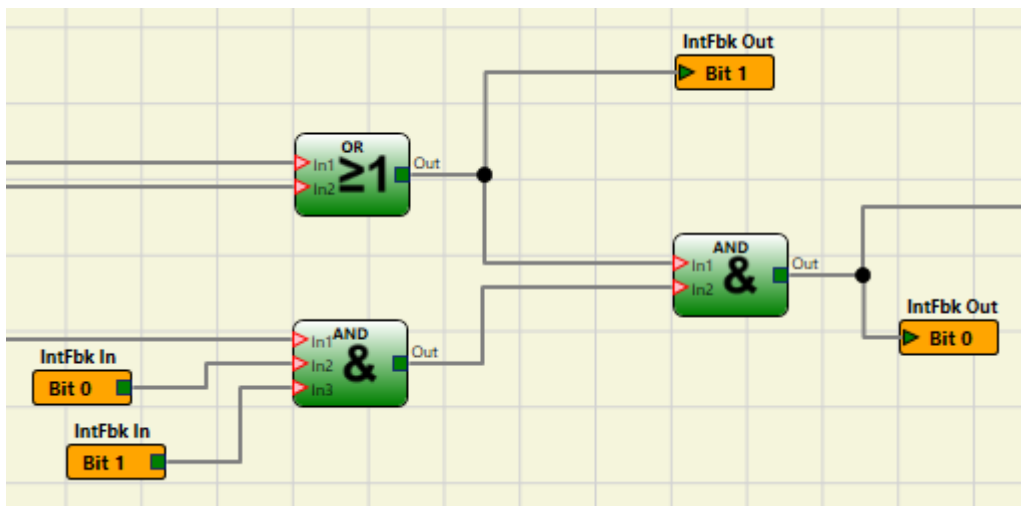

Figure 215: Example: input/output for internal feedback

Parameters

Bit: Specification of the internal bit at which IntFbk_Out links the value to IntFbk_In.



WARNING

The feedback loops can produce dangerous system oscillations and make the system unstable if this is not designed carefully. An unstable system can have serious consequences for the user, e.g. severe injuries or death.

9.6. Special applications

9.6.1. Output delay with manual operating mode

If two OSSD outputs are required and one output is to be delayed (in the MANUAL operating mode), the following diagram is to be used:

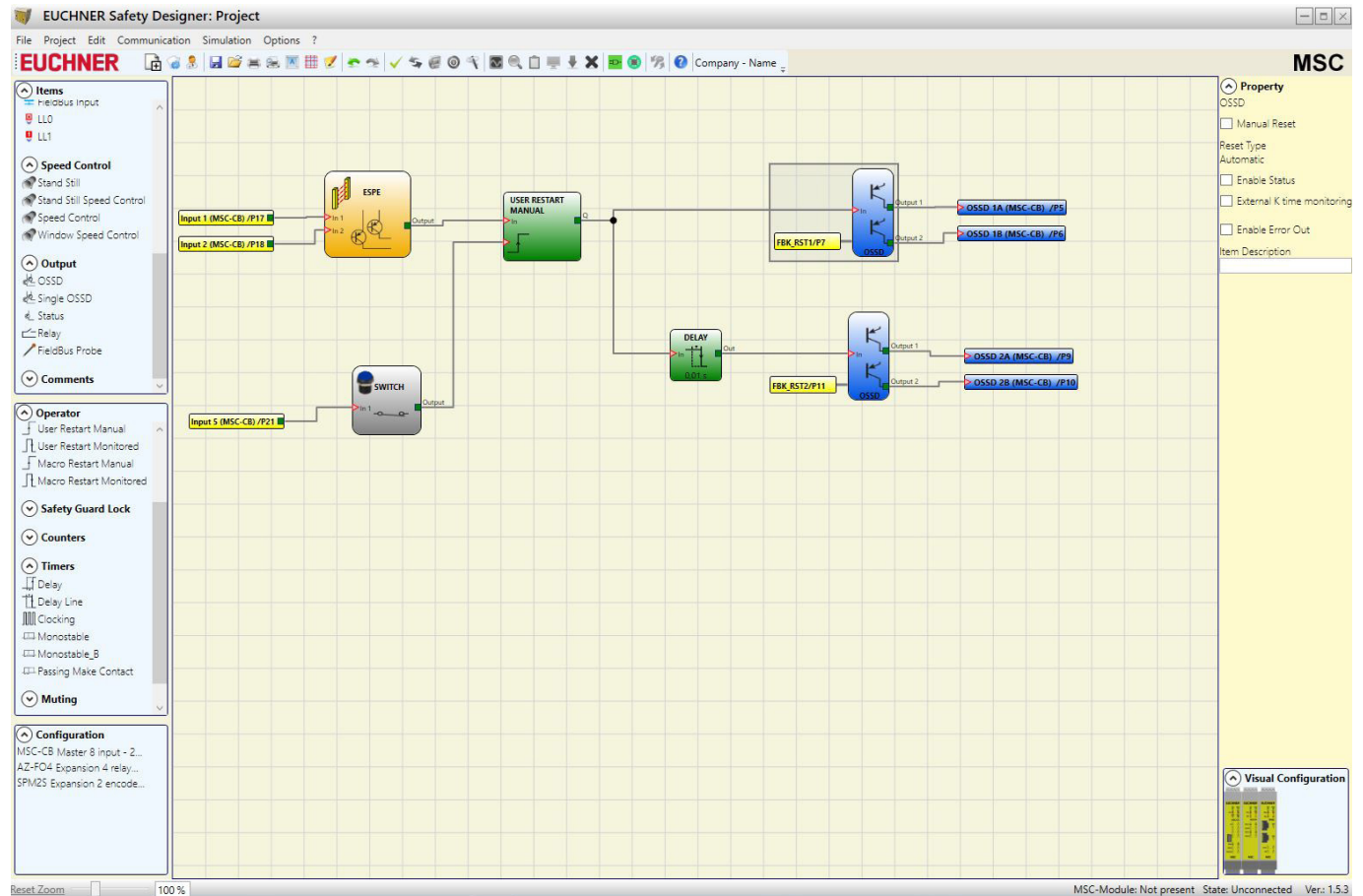

Figure 216: Two outputs, of these one output delayed (MANUAL operating mode)

- ➔ If the Delay operator is used, the application must be as follows:
 - The two outputs must be programmed via the USER RESTART MANUAL function with automatic reset.

9.7. Simulator



Important!

- › This simulator has been designed purely as a planning aid during the design of the safety function.
- › The result of the simulation must not be considered confirmation of the suitability of the project.
- › The hardware and software for the resulting safety function must be validated in real situations according to the applicable standards, e.g. ISO/EN 13849-2 for validation or IEC/EN 62061: chapter 8 for the validation of safety-related electrical control systems.
- › You will find the safety parameters for MSC configuration in the report from the EUCHNER SAFETY DESIGNER software.

In the toolbar at the top there are two new green icons (from firmware MSC-CB version 3.0 or higher):

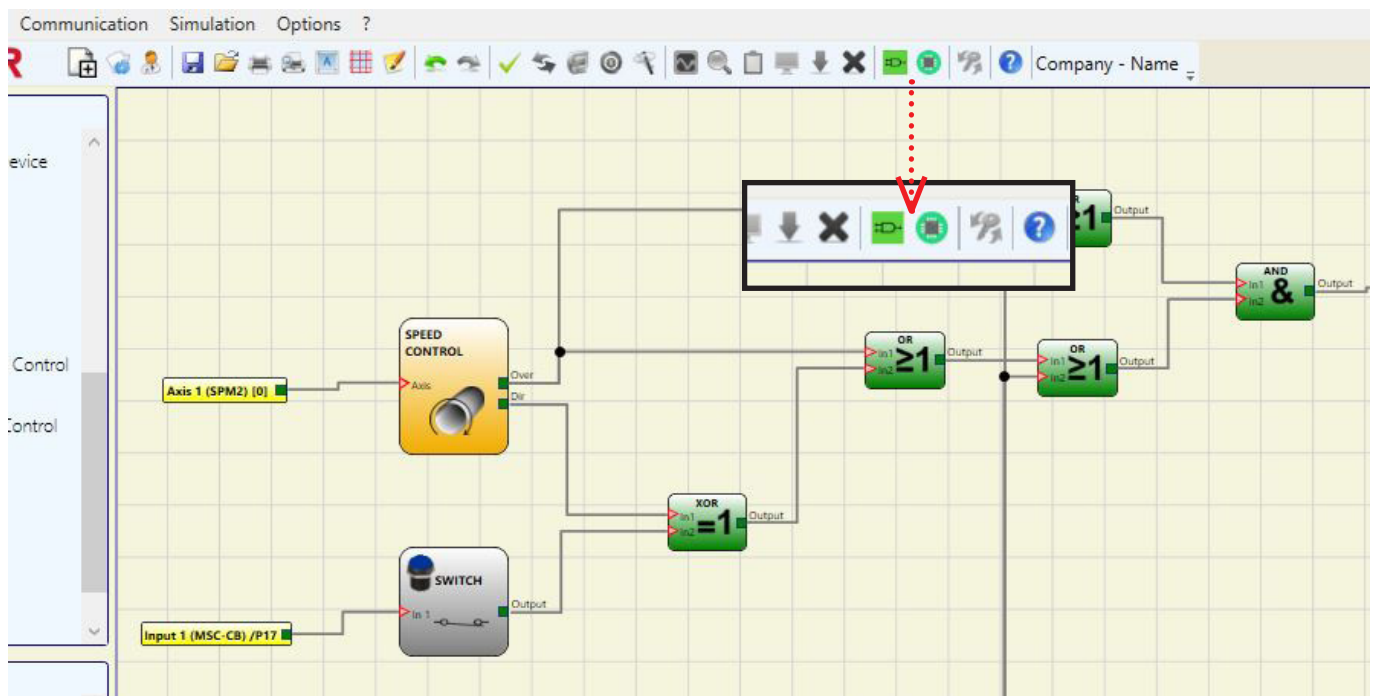



Figure 217: The icons for the simulator function

These icons relate to the new simulator function.

- › The first icon  displays the “Schematic Simulation.” It activates the schematic simulator (both statically or dynamically) in which the user can activate the INPUT to check the loaded plan.
 - › The second icon  is for the “Graphic Simulation.” It activates the simulator controlled via the file with stimuli; this simulator permits the display of the required traces in a specific diagram.
- ➔ THE SIMULATION ICONS ARE AVAILABLE ONLY IF THE BASE UNIT IS NOT CONNECTED.

9.7.1. Schematic simulation

Activate the schematic simulation by clicking the  icon.

The schematic simulation permits the checking/controlling of the signal on the output from the various function blocks in real time, i.e. during the actual simulation. The user can select as required which outputs on the blocks are to be operated and check the reaction of the different elements of the schematic diagram based on the color of the different lines.

As for the Monitor function, the color of the line (or the same button) indicates the signal state: green signifies signal LL1, red LLO.

During the “Schematic Simulation” various new buttons appear on the toolbar. The simulation can be administered using these buttons. They can be used to start the simulation (“Play” button), stop the simulation (“Stop” button), run the simulation step-by-step (“PlayStep” button) or reset the simulation (“Reset” button). If the simulation is reset, the time is reset to 0 ms.

On starting the simulation by pressing the “Play” button, the sequence over time can be monitored in the “Time” field. The time elapses as per the “Step” time unit, which is multiplied by the “KT” factor selected by the user.

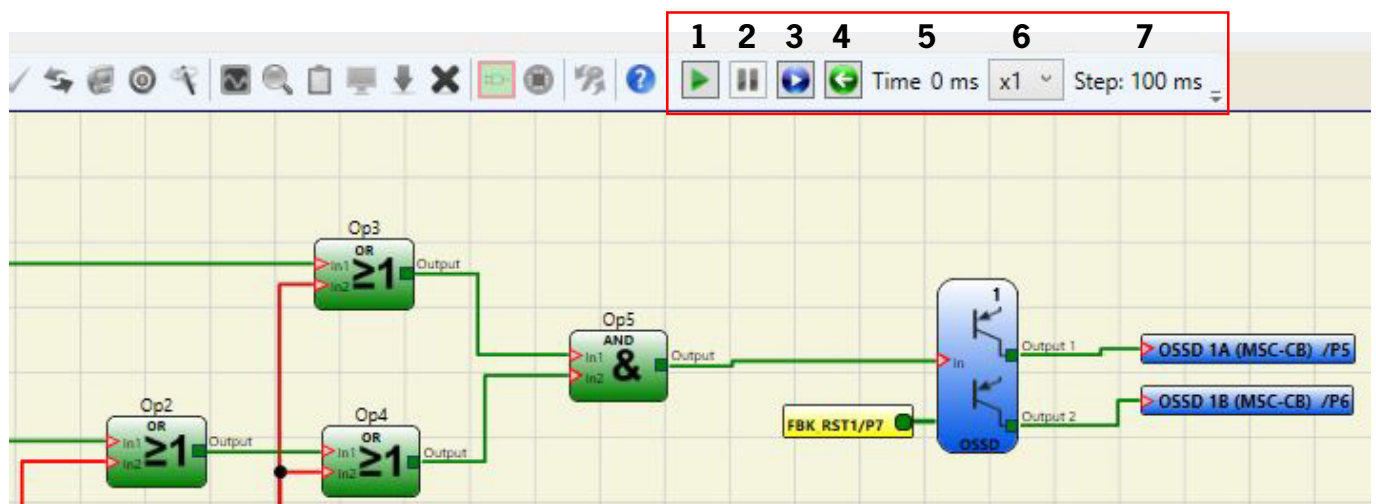

Figure 218: Circuit diagram simulation





Number	Symbol	Description
1		Play button
2		Stop button
3		Play Step button
4		Reset button
5	Time 0 ms	Time
6	x1	KT
7	Step: 100 ms	Simulation step

Table 87: Key

By clicking the button at the bottom right corner of each input block, the related output status can be activated (also if the simulation is interrupted, i.e. if the time is not running – the simulation is then “static”). If the button is red after clicking it, the output is “0” (“LOW”) and, conversely, if the button is green, the output is “1” (“HIGH”).

In some function blocks, for example “Speed control” or “Lock feedback,” the button is gray. This color indicates that the value is entered manually using a corresponding pop-up window and the type of value to be entered changes depending on the type of function block (for example, it is necessary to enter a frequency in the “Speed control” block).

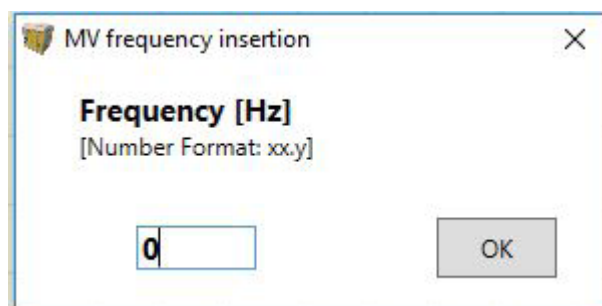
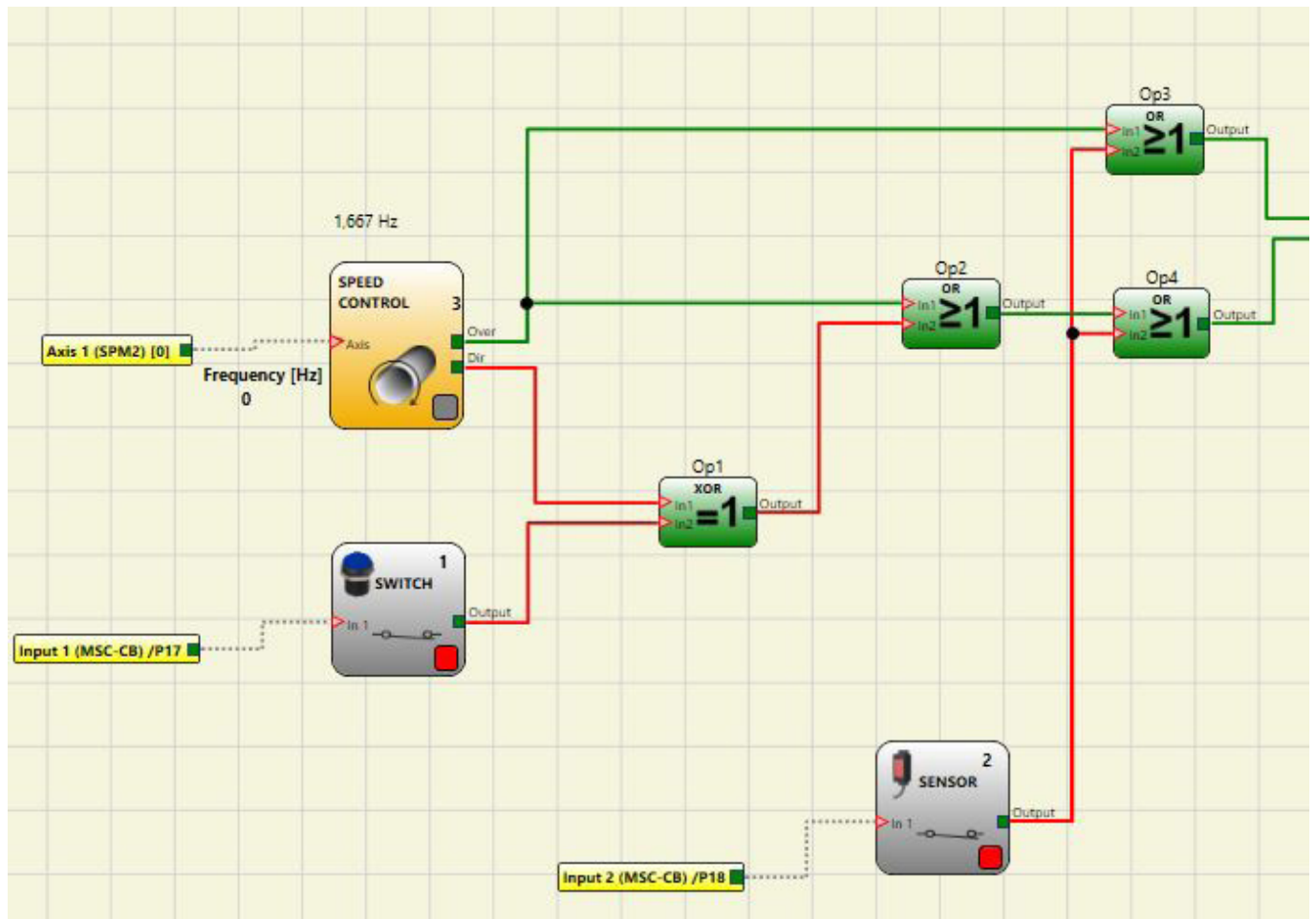

Figure 219: The buttons for activating the block outputs are at the top; there is a pop-up example below. In this case, it is necessary to enter the frequency for the “Speed control” function block.

9.7.2. Administration of the graphic simulation

Activate the graphic simulation by clicking the  icon.

The graphic simulation makes it possible to show the change in the signals graphically. The user must first specify in a text file the stimuli, i.e. the waveforms over time, that are used as inputs (stimuli). The simulator converts the stimuli file prepared into a diagram and displays the required traces at the end of the simulation.

As soon as the simulation is finished, a diagram as shown below appears automatically. From the diagram it is possible to print the traces displayed ("Print" button), to save the results, to load them again ("Save" button), and to display other traces ("Change visibility"). The identifiers for the traces are the same as in the function block description.

Click the "Close" button ("X" button at top right) to close the graphic simulation environment.

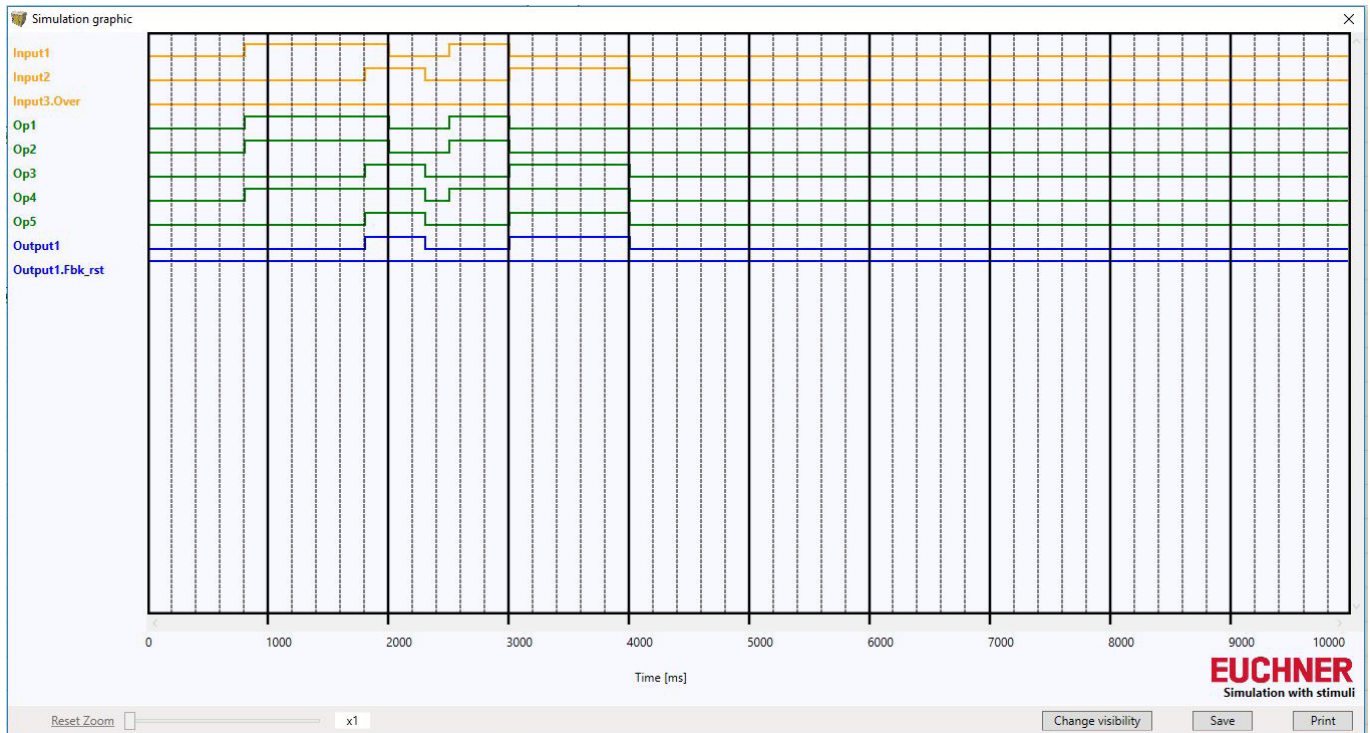



Figure 220: Example for a result from the graphic simulation: The traces can be seen on the screen along with the three buttons at the bottom right; these buttons can be used to select the traces, save and print them.

To perform the simulation, as a minimum the following process steps are necessary:

1. Prepare a stimuli file as required
2. Load the stimuli file and wait until the simulation is finished

After you click the  icon, the following screen appears:

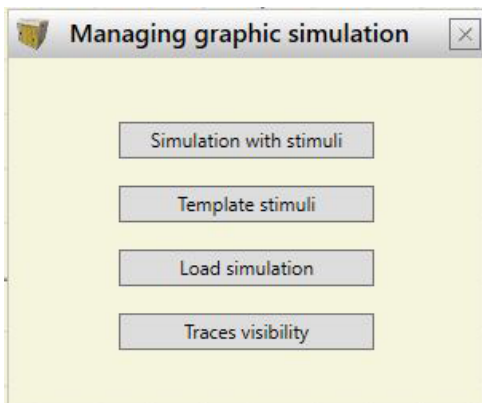

Figure 221: Selection menu for the graphic simulation mode

The individual buttons on the menu are described in detail in the following (see *Figure 45*):

Template Stimuli button: Makes it possible to save the template file with the required name in the required storage location on the hard disk. This file contains the signal identifiers as per the diagram (see *Figure 222*). Here, with the aid of a text editor, the operator can enter the status of the input signals at a specific time as well as the duration of the simulation and the time step to be used (see *Figure 223*).

```

Example.sti - Editor
Datei Bearbeiten Format Ansicht ?
// Stimulus Template

//Sim 0:EndTime:Step (time unit ms)
Sim 0:10000:100

// Switch
Input1
0:0
Time1:1
Time2:0

// Sensor
Input2
0:0
Time1:1
Time2:0

// Speed Control
// Only Integer numbers!!
SpeedInput3
0:8 Hz
Time1:2500 Hz
Time2:300 Hz

// OSSD
Fbk_rst1
0:1
Time1:0
Time2:1
    
```

Figure 222: Template file immediately after saving

```

Example 2.sti - Editor
Datei Bearbeiten Format Ansicht ?
// Stimulus Template

//Sim 0:EndTime:Step (time unit ms)
Sim 0:10000:100

// Switch
Input1
0:0
800:1
2000:0
2500:1
2950:0

// Sensor
Input2
0:0
1800:1
2250:0
2950:1
3950:0

// Speed Control
// Only Integer numbers!!
SpeedInput3
0:8 Hz
200:1400 Hz
2000:300 Hz

// OSSD
Fbk_rst1
0:1
    
```

Figure 223: Example of a completed template file

Simulation with stimuli button: Makes it possible to upload a (completed) template file. The simulation can be started immediately after uploading.

A diagram with the resulting signals is displayed at the end of the simulation.

Load simulation: button: Makes it possible to load a simulation completed earlier, provided at least one simulation has been saved.

Traces visibility button: Makes it possible to display graphically the traces selected (in the form of signal waveforms) as a diagram. As soon as it is clicked, the button opens a pop-up window as shown in *Figure 224*. The traces can be removed from the diagram or added to the diagram in this window.

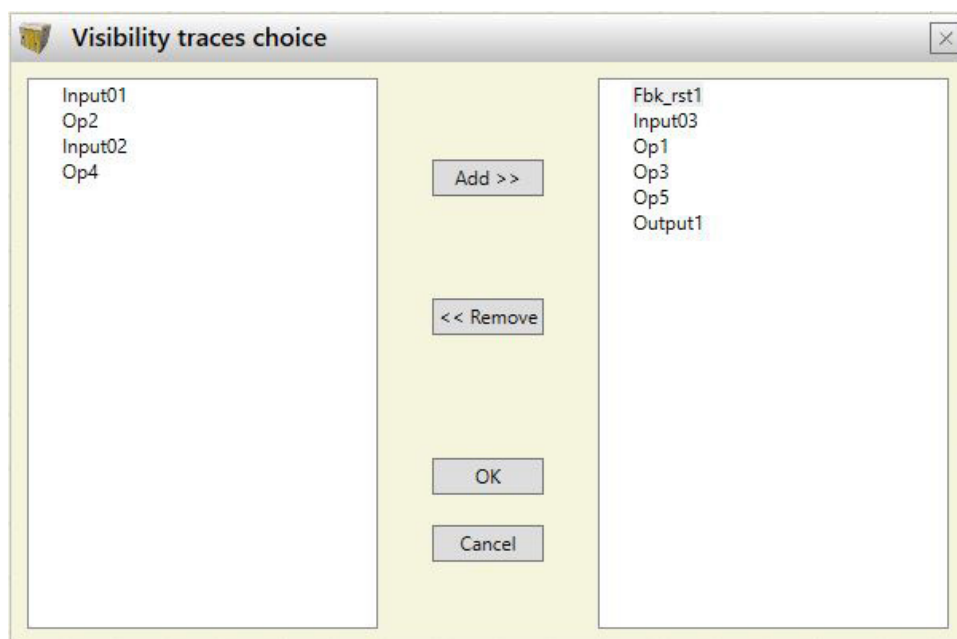

Figure 224: Displaying the traces. The traces that can be added to the diagram are shown in the pane on the left. The traces currently shown in the diagram are displayed in the pane on the right; these traces can also be removed from the diagram.

9.7.2.1. Application example for the graphic simulation

The following example relates to the use of a press that has been installed inside a safety zone. The motor of the press can be operated only if two conditions are met at the same time: the gate of the safe area is closed and the motor activation command has been issued. The drive is to start with a delay of two seconds after the start signal.

Diagram

The input elements are represented in the diagram by the door for the safe zone and by the control system for the motor drive. These two signals are used as inputs for the AND logical operator; the result from this operator is delayed by two seconds by a delay block. The relay is then operated by the delayed signal; in turn the relay makes it possible to operate the press motor.

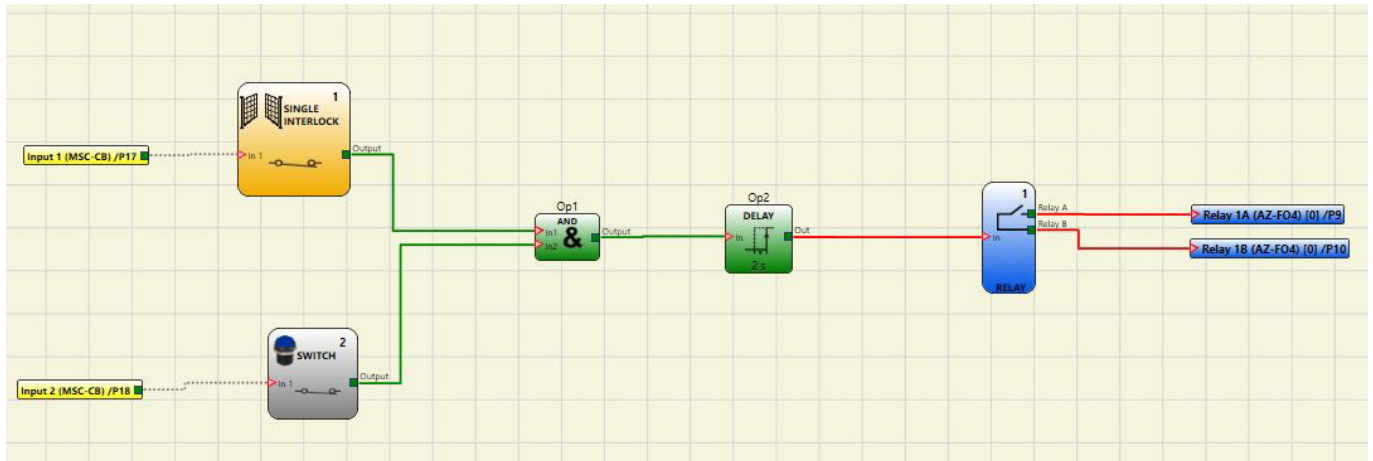

Figure 225: Diagram for the application example

Stimuli file

The stimuli file provides for the closing of the gate after 2,000 ms (signal at LL1) and the activation command from the operator at 3,000 ms (signal at LL1).

```
// Stimulus Template

//Sim 0:EndTime:Step (time unit ms)
Sim 0:10000:100

// Single Interlock
Input1
0:0
2000:1
10000:0

// Switch
Input2
0:0
3000:1
10000:0
```

Figure 226: Stimuli file for the application example

Result of the simulation

The signals from the simulation are shown in the diagram. In this case:

- › At 2,000 ms, the “Safe Zone” signal changes to logic level 1. It indicates the closing of the gate.
- › At 3,000 ms, the “Start_Press” signal changes to logic level 1. It indicates the request for activation by the operator.
- › The output signal of the AND operator „Op1“ increases to logic level 1 at 3,000 ms. This occurs when the two inputs “Safe Zone” and “Start_Press” change to logic level 1.
- › The signal on the output of the AND operator is delayed by 2,000 ms by the Delay operator.
- › The signal at the output of delay block “Op2” issues the command to close the relay at 5,000 ms. At this point, the relay “M_Press” is activated.

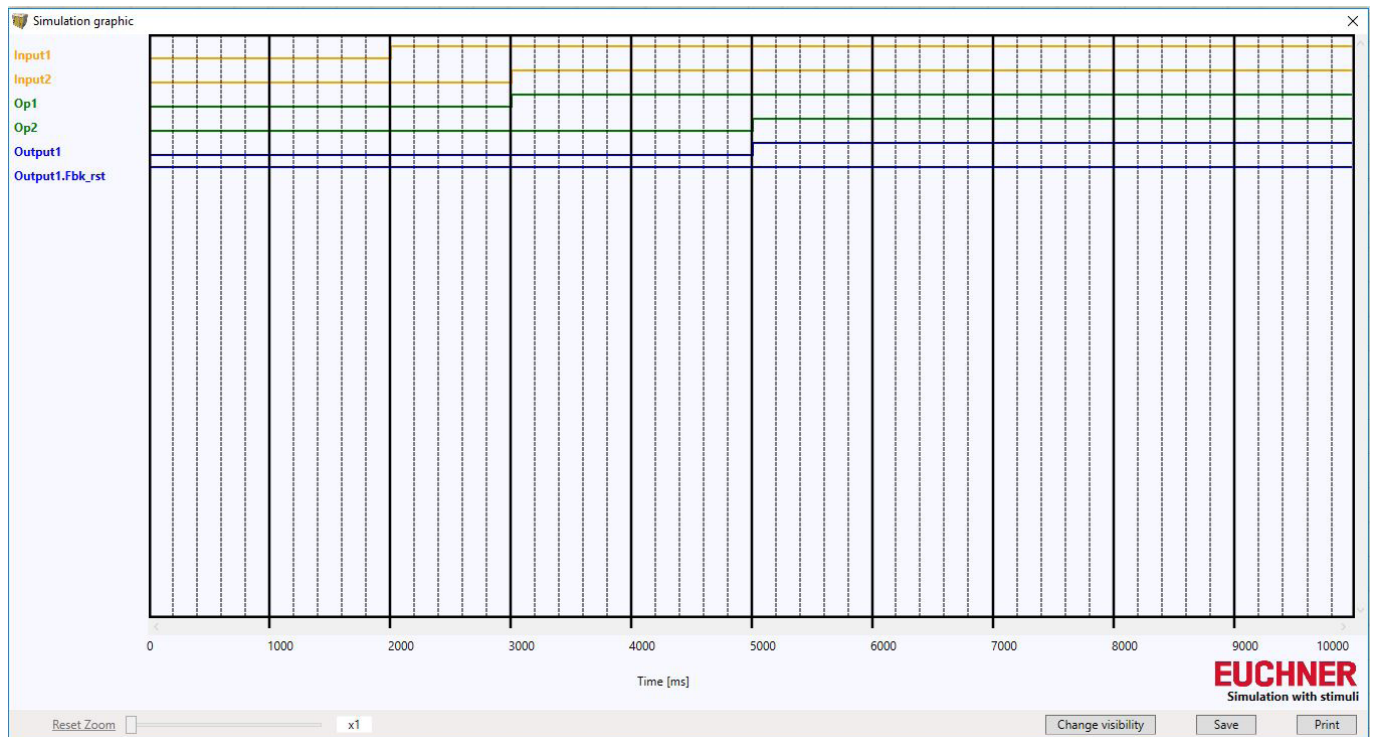



Figure 227: Diagram resulting from the simulation of the application example

9.7.3. MSC error codes

If there is a malfunction, the MSC system sends a code that corresponds to the error detected by the base unit to the EUCHNER Safety Designer software.

The code can be read as follows:

- ▶ Connect the base unit (indicates ERROR via LED) to the PC using the USB cable.
- ▶ Start EUCHNER SAFETY DESIGNER software.
- ▶ Establish the connection using the  icon; a window appears with the password prompt; type the password; a window appears with the error code acquired.

All possible errors with the corresponding solution are listed in the following.

CODE	FAIL	SOLUTION
19D	The two microcontrollers MSC-CB do not have the same hardware/software configuration.	CHECK MSC-CB AND MSC PLUG CONNECTORS ON THE EXTENSION MODULES FOR CORRECT SEATING. REPLACE PLUG CONNECTORS IF NECESSARY.
66D	There are two or more extension modules with the same node number.	CHECK CONNECTIONS – PINS 2 and 3 ON THE EXTENSION MODULES
68D	Maximum number of extension modules exceeded.	DISCONNECT EXCESS MODULES (MAX: 14)
70D	A change in the node number has been detected on one or more modules.	CHECK CONNECTIONS – PINS 2 and 3 ON THE EXTENSION MODULES
73D	An external error has been detected on a slave module.	SEE ERROR CODE ON THE MODULE FOR MORE INFORMATION
96D ÷ 101D	Error in relation to the M-A1 memory card.	REPLACE M-A1 MEMORY CARD
137D	From a module AZ-FO4 or AZ-FO408 – EDM error on the pair RELAY1 and RELAY2 for category 4.	CHECK CONNECTION OF THE EXTERNAL FEEDBACK CONTACTORS
147D	From a module AZ-FO4 or AZ-FO408 – EDM error on the pair RELAY2 and RELAY3 for category 4.	CHECK CONNECTION OF THE EXTERNAL FEEDBACK CONTACTORS
157D	From a module AZ-FO4 or AZ-FO408 – EDM error on the pair RELAY3 and RELAY4 for category 4.	CHECK CONNECTION OF THE EXTERNAL FEEDBACK CONTACTORS
133D (Proxi1) 140D (Proxi2)	From a module SPM2, SPM1 or SPM0 – overfrequency acquired on the proximity switch input.	THE INPUT FREQUENCY MUST BE < 5 KHz
136D (Encoder1) 143D (Encoder2)	From a module SPM2, SPM1 or SPM0 – encoder input signals outside the standard (duty cycle, phase offset) acquired.	THE DUTY CYCLE MUST HAVE THE FOLLOWING VALUE: 50% + 33% OF THE PERIOD (HTL, TTL). THE PHASE OFFSET MUST HAVE THE FOLLOWING VALUE: 90° + 45° (HTL, TTL) (not applicable to SIN/COS)
138D (Encoder1) 145D (Encoder2)	From a module SPM2, SPM1 or SPM0 – overfrequency acquired on the encoder input.	THE INPUT FREQUENCY MUST BE: < 500 kHz (TTL, SIN/COS); < 300 kHz (HTL).
130D 135D 137D 138D 140D 194D 197D 198D 199D 201D 202D 203D 205D	Error on static output OSSD1.	CHECK CONNECTIONS OF OSSD1 FOR MODULE WITH ERROR
144D 149D 151D 152D 154D 208D 211D 212D 213D 215D 216D 217D 219D	Error on static output OSSD2.	CHECK CONNECTIONS OF OSSD2 FOR MODULE WITH ERROR
158D 163D 165D 166D 168D 222D 225D 226D 227D 229D 230D 232D 233D	Error on static output OSSD3.	CHECK CONNECTIONS OF OSSD3 FOR MODULE WITH ERROR
172D 177D 179D 180D 182D 236D 239D 240D 241D 243D 244D 245D 247D	Error on static output OSSD4.	CHECK CONNECTIONS OF OSSD4 FOR MODULE WITH ERROR

Table 88: Overview of error codes

All other codes relate to an internal malfunction. Please check any malfunctions against this table and state on returning to EUCHNER.

CODE	FAIL	SOLUTION
1D ÷ 31D	Error on microcontrollers	RESTART SYSTEM. IF THE ERROR PERSISTS, SEND THE MODULE TO EUCHNER FOR REPAIR.
32D ÷ 63D	Error on main printed circuit board	
64D ÷ 95D	Error in the communication between the modules	
96D ÷ 127D	Error on the M-A1 memory card	REPLACE M-A1 MEMORY CARD
128D ÷ 138D	Error on the module AZ-FO4, relay 1	RESTART SYSTEM. IF THE ERROR PERSISTS, SEND THE MODULE TO EUCHNER FOR REPAIR.
139D ÷ 148D	Error on the module AZ-FO4, relay 2	
149D ÷ 158D	Error on the module AZ-FO4, relay 3	
159D ÷ 168D	Error on the module AZ-FO4, relay 4	
128D ÷ 191D	Error on the encoder interface of the SPM modules	RESTART SYSTEM. IF THE ERROR PERSISTS, SEND THE MODULE TO EUCHNER FOR REPAIR.
192D ÷ 205D	Error OSSD1	
206D ÷ 219D	Error OSSD2	
220D ÷ 233D	Error OSSD3	
234D ÷ 247D	Error OSSD4	

Table 89: Overview of error codes, internal malfunction

9.7.4. Error log file

The error log file can be displayed using the  icon on the default toolbar.

(required password: level 1)

A table is displayed with the last 5 errors that have occurred since the scheme was last sent to the MSC or the last time the error log was deleted (icon: ).

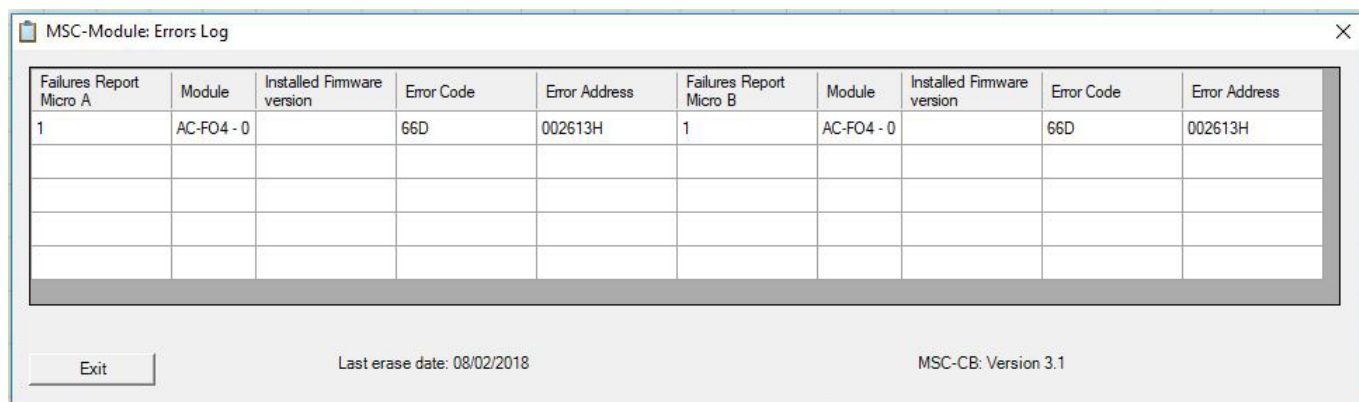

Failures Report Micro A	Module	Installed Firmware version	Error Code	Error Address	Failures Report Micro B	Module	Installed Firmware version	Error Code	Error Address
1	AC-FO4 - 0		66D	002613H	1	AC-FO4 - 0		66D	002613H

Exit Last erase date: 08/02/2018 MSC-CB: Version 3.1

Figure 228: Error log file

10. Ordering information and accessories



Tip!

Suitable accessories, e.g. cables or assembly material, can be found at www.euchner.com. To order, enter the order number of your item in the search box and open the item view. Accessories that can be combined with the item are listed in "Accessories."

11. Inspection and service



WARNING

Danger of severe injuries due to the loss of the safety function.

- › If damage or wear is found, the respective MSC module must be completely replaced. Replacement of individual parts or assemblies is not permitted.
- › Check the device for proper function at regular intervals and after every fault. For information about possible time intervals, refer to EN ISO 14119:2013, section 8.2.

No servicing is required. Repairs to the device are only allowed to be made by the manufacturer.

12. Service

If servicing is required, please contact:

EUCHNER GmbH + Co. KG
Kohlhammerstraße 16
70771 Leinfelden-Echterdingen

Service telephone:

+49 711 7597-500

E-mail:

support@euchner.de

Internet:

www.euchner.com

13. Declaration of conformity



EU-Konformitätserklärung
EU declaration of conformity
Déclaration UE de conformité
Dichiarazione di conformità UE
Declaración UE de conformidad

Original DE
 Translation EN
 Traduction FR
 Traduzione IT
 Traducción ES

2122800-07-09/20

Die nachfolgend aufgeführten Produkte sind konform mit den Anforderungen der folgenden Richtlinien (falls zutreffend):
The beneath listed products are in conformity with the requirements of the following directives (if applicable):
Les produits mentionnés ci-dessous sont conformes aux exigences imposées par les directives suivantes (si valable)
I prodotti sotto elencati sono conformi alle direttive sotto riportate (dove applicabili):
Los productos listados a continuación son conforme a los requisitos de las siguientes directivas (si fueran aplicables):

I:	Maschinenrichtlinie <i>Machinery directive</i> <i>Directive Machines</i> <i>Direttiva Macchine</i> <i>Directiva de máquinas</i>	2006/42/EG 2006/42/EC 2006/42/CE 2006/42/CE 2006/42/CE
II:	EMV Richtlinie <i>EMC Directive</i> <i>Directive de CEM</i> <i>Direttiva EMV</i> <i>Directiva CEM</i>	2014/30/EU 2014/30/EU 2014/30/UE 2014/30/UE 2014/30/UE
III:	RoHS Richtlinie <i>RoHS directive</i> <i>Directive de RoHS</i> <i>Direttiva RoHS</i> <i>Directiva RoHS</i>	2011/65/EU 2011/65/EU 2011/65/UE 2011/65/UE 2011/65/UE

Folgende Normen sind angewandt:

Following standards are used:

Les normes suivantes sont appliquées:

Vengono applicate le seguenti norme:

Se utilizan los siguientes estándares:

EN 61131-2:2007	EN 61508-3:2010 (SIL3)
EN ISO 13849-1:2015 (Cat 4, PL e)	EN 61508-4:2010 (SIL3)
EN 61508-1:2010 (SIL3)	EN 62061:2005/A2:2015 (SIL CL3)
EN 61508-2:2010 (SIL3)	EN IEC 63000:2018 (RoHS)

Bezeichnung der Sicherheitsbauteile <i>Description of safety components</i> <i>Description des composants sécurité</i> <i>Descrizione dei componenti di sicurezza</i> <i>Descripción de componentes de seguridad</i>	Type <i>Type</i> <i>Type</i> <i>Tipo</i> <i>Typo</i>	Richtlinie <i>Directives</i> <i>Directive</i> <i>Direttiva</i> <i>Directivas</i>	Zertifikats-Nr. <i>No. of certificate</i> <i>Numéro du certificat</i> <i>Numero del certificato</i> <i>Número del certificado</i>
MSC Master-Modul <i>MSC master unit</i> <i>MSC unité principale</i> <i>MSC unità principale</i> <i>MSC unidad principal</i>	MSC-CB-AC-FI8FO2 MSC-CB-AC-FI8FO4S	I, II, III	Z10 40393 0030
MSC Erweiterungsmodule <i>MSC expansion modules</i> <i>MSC modules d'extension</i> <i>MSC moduli espansioni</i> <i>MSC módulos de expansión</i>	MSC-CE-AC... MSC-CE-AZ... MSC-CE-CI... MSC-CE-FI... MSC-CE-FM... MSC-CE-SPM... MSC-CE-O8... MSC-CE-O16... MSC-CE-AH...	I, II, III	Z10 40393 0030
MSC Feldbus-Module <i>MSC fieldbus modules</i> <i>MSC modules de bus d'automatisation</i> <i>MSC moduli di bus di automazione</i> <i>MSC módulos del bus de automatización</i>	MSC-CE-US MSC-CE-PN MSC-CE-PR MSC-CE-DN MSC-CE-CO MSC-CE-EC MSC-CE-EI MSC-CE-MR MSC-CE-MT MSC-CE-EI2	II, III	Z10 40393 0030

Benannte Stelle

Notified Body

Organisme notifié

Sede indicata

Entidad citada

0123

TÜV SÜD Product Service GmbH

Ridlerstraße 65 - 80339 München - Germany



EUCHNER

More than safety.

Die alleinige Verantwortung für die Ausstellung dieser Konformitätserklärung trägt der Hersteller:
This declaration of conformity is issued under the sole responsibility of the manufacturer:
La présente déclaration de conformité est établie sous la seule responsabilité du fabricant:
La presente dichiarazione di conformità è rilasciata sotto la responsabilità esclusiva del fabbricante:
La presente declaración de conformidad se expide bajo la exclusiva responsabilidad del fabricante:

EUCHNER GmbH + Co. KG
Kohlhammerstraße 16
70771 Leinfelden-Echterdingen
Germany

Leinfelden, September 2020

EUCHNER GmbH + Co. KG
Kohlhammerstraße 16
70771 Leinfelden-Echterdingen
Germany

Dipl.-Ing. Richard Holz
Leiter Elektronik-Entwicklung
Manager Electronic Development
Responsable Développement Électronique
Direttore Sviluppo Elettronica
Director de desarrollo electrónico

i.A. Dipl.-Ing. (FH) Duc Binh Nguyen
Dokumentationsbevollmächtigter
Documentation manager
Responsable documentation
Responsabilità della documentazione
Agente documenta

Euchner GmbH + Co. KG
Kohlhammerstraße 16
70771 Leinfelden-Echterdingen
info@euchner.de
www.euchner.com

Edition:
2121331-06-02/21
Title:
Operating Instructions
Modular Safety Control System MSC
(Translation of the original operating instructions)
Copyright:
© EUCHNER GmbH + Co. KG, 02/2021

Subject to technical modifications; no responsibility
is accepted for the accuracy of this information.