

# DIN Rail Mountable Switching Power Supply

Output Power 100 watts



## Technical Data Installation and Operation

### DEFINITION OF MODELS

SPD241001

- 24 : Output Voltage
- 12 .... 12Vdc output
- 24 .... 24Vdc output
- 48 .... 48Vdc output

Fig. 1

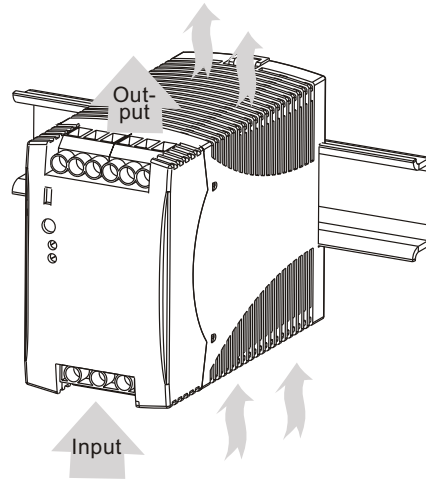
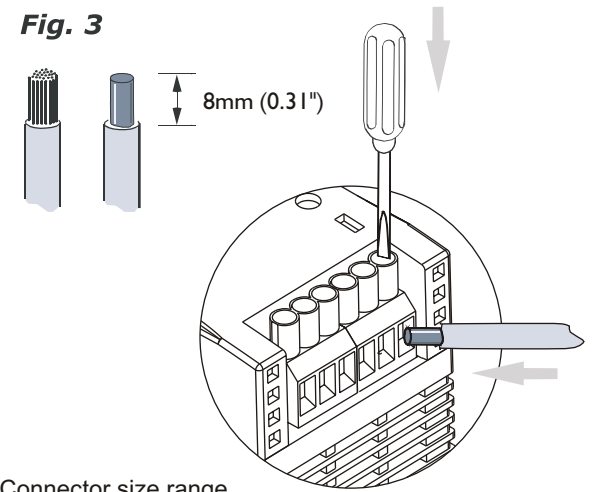

Fig. 3



Connector size range

\* AWG24 - 10

- Input connector can withstand torque at maximum 1.01Nm (9lb-in)
- Output connector can withstand torque at maximum 0.621Nm (5.5lb-in)

Use copper conductors only, 60/75 °C (140/167 °F)  
Max. surrounding air temperature 50 °C (122 °F) for UL508

Fig. 2

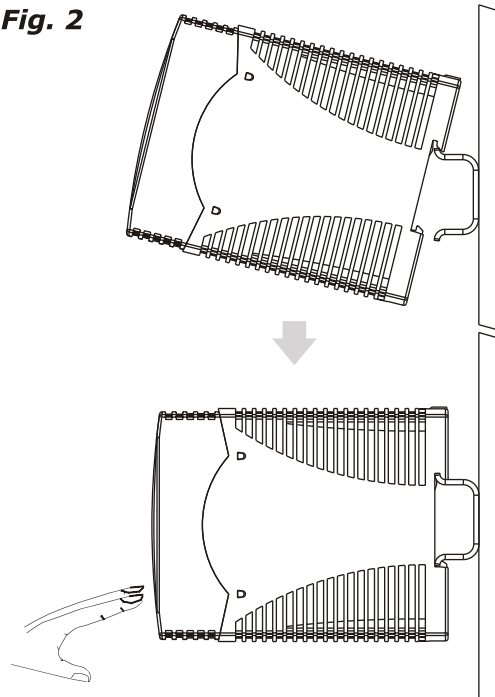
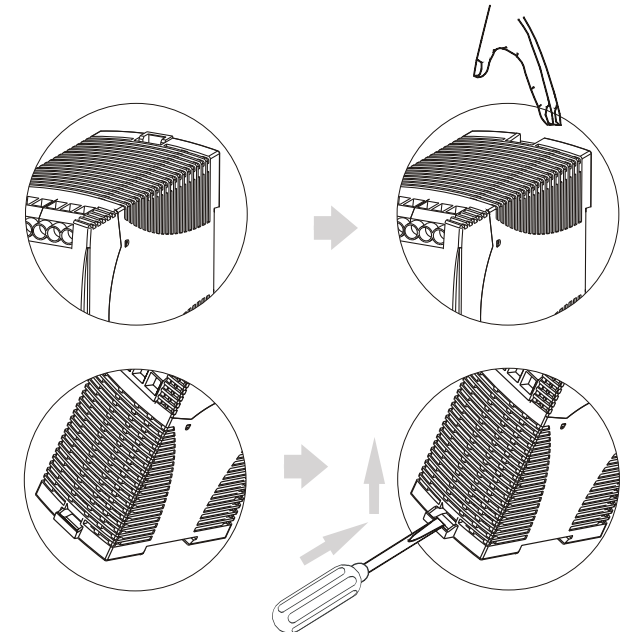

Fig. 4





## Safety notes

### Read Instructions!

Before working with this unit, read these instructions carefully and completely. Make sure that you have understood all the information!

### Disconnect system from supply network

Before any installation, maintenance or modification work: Disconnect your system from the supply network. Ensure that cannot be re-connected inadvertently!

### Before start of operation

#### Ensure appropriate installation

Warning! Improper installation / operation impair safety and result in operational difficulties or complete failure of the unit. The unit must be installed and put into service appropriately by qualified personnel. Compliance with the relevant regulations must be ensured. Before operation is begun the following conditions must be ensured, in particular:

- Connection to main power supply in compliance with VDE0100 and EN50178.
- With stranded wires: all strands must be secured in the terminal blocks (potential danger of short circuit).
- Unit and power supply cables must be properly fused; if necessary a manually controlled disconnecting element must be used to disengage from supply mains.
- The non-fused earth conductor must be connected to the "⊕" terminal (protection class 1).
- All output lines must be rated for the power supply output current and must be connected with the correct polarity.
- Sufficient air-cooling must be ensured.
- Use in a pollution degree 2 environment

### In operation: No modifications!

As long as the unit is in operation: do not modify the installation! The same applies also to the secondary side. Risk of electric arcs and electric shock (fatal)!

**Only (dis) connect plug connectors when the power is off!**

### Convection cooling

**Do not cover** any ventilation holes!  
**Leave sufficient space** around the unit **for cooling!**  
See supplementary sheet "Technical Data" and Fig. 1

### Warning: High voltage! Store energy!

The unit contains unprotected conductors carrying a lethal high voltage, and components storing substantial amounts of energy. Improper handling may result in an electric shock or serious burn!

- The unit must not be opened except appropriately trained personnel!
- Do not introduce any object into the unit!
- Keep away from fire and water!

## Installation

### Application

This unit is a primary switched-mode power supply designed **for use in panel-board installations or building-in applications** where access to the supply is restricted (shock-hazard protection). It must only be installed and put into service appropriately by qualified personnel.

### Mounting

#### Mounting

Permissible mounting position: see Fig. 1 keep free ventilation hole, leave space for cooling! Recommended to have 25mm free space at all sides for ventilation / cooling: see supplementary sheet "Technical Data".

#### Snap on support rail (See Fig. 2)

- Tilt the unit slightly rearwards.
- Fit the unit over top hat rail.
- Slide it downward until it hits the stop.
- Press against the bottom front side for locking.
- Shake the unit slightly to check the locking action.

## Front elements

### Operation indicator

The green LED lights up while the PSU working properly.

### DC output low indicator

The red LED lights up while the output voltage is too low.

### Potentiometer

Setting the output voltage.

## Connection / Internal fuse

### Connection

- Data for permitted loads, cable cross-sections and stripping: see enclosed leaflet " Technical Data " (See Fig. 3).
- Use only commercial cables designed for the indicated voltage and current values!
- With flexible cables: make sure that all stranded cable are secured in the terminal.
- Ensure proper polarity at output terminals!

### Grounding

- **Do not operate without PE connection!** To comply with EMC and safety standards (CE mark, approvals), the unit must only be operated if the PE terminal ⊕ is connected to the non-fused earth conductor.
- Secondary side is not earthed; if necessary the ⊕ or ⊖ terminal can be earthed optionally.

### Internal fuse

The internal input fuse serves to protect the unit and must not be replaced by the user. In case of an internal defect, the unit must be returned to the manufacturer for safety reasons.

## Removal

### Removal from DIN Rail

Insert a flat screwdriver into the slot in the clamp. Pull down the clamp out until the clamp clicks, and turn the switching power supply bottom out. (See Fig. 4)

## Technical Data

All specifications are typical at nominal line, full load, 25°C; Unless otherwise noticed.

Output Power	Vo [V]	Io [A]	Eff. [typ.]	Inrush Current	
				115Vac	230Vac
100	12	8.4	84%	<30A	<60A
	24	4.2	86%		
	48	2.1	88%		
91.2	24	3.8	85%		

### General Specification

Isolation ..... 3000 Vac / 4242 Vdc  
 Isolation Resistance..... 100 M ohm  
 Operation amb. Temperature.... -35 ~ +71 °C  
 Storage Temperature..... -40 ~ +85 °C  
 Derating..... +61 ~ +71 °C (see Fig. 5)  
 Relative Humidity..... 20 - 95% RH  
 Cooling..... Free air convection  
 Temperature Coefficient..... 0.03% / °C  
 Dimension..... L90 x W54 x D114 [mm]  
 Weight..... 430g

### Input Specification

Rated Input Voltage..... 100 ~ 240 Vac  
 Input Voltage Range..... 90 ~ 264 Vac or 120 ~ 375 Vdc  
 Rated Input Current..... 2.4A  
 Line frequency ..... 47 - 63Hz  
 Power Factor..... 0.55@230 Vac

Fig. 5 Derating

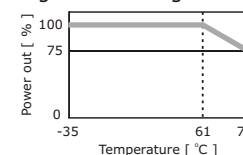

### Output Specification

Output Accuracy..... +0 ~ 1%  
 Line Regulation ..... ± 1%  
 Load Regulation..... ± 1% for single mode  
 ± 5% for parallel mode  
 Ripple & Noise ..... 50 mV  
 Voltage Trim Range..... 11.4 ~ 14.5 Vdc for 12V model  
 22.5 ~ 28.5 Vdc for 24V model  
 47 ~ 56 Vdc for 48V model  
 22.5 ~ 24.5 Vdc for 91.2W model  
 DC ON Indicator..... Green LED  
 DC LOW Indicator..... Red LED  
 Parallel Operation..... 3 unit max.  
 Turn on time..... <1000ms  
 Fall time..... <150ms  
 Rise time..... <150ms  
 Hold up time..... >15ms  
 Case material..... Plastic

### Control And Protection

Input Internal Fuse..... T3.15A / 250 Vac  
 Output Short Circuit ..... Fold Forward  
 Output Over Load..... 110 % ~ 140 %  
 102 % ~ 108 % for 91.2W model

### Approvals And Standard

UL / cUL..... UL 508 Listed , UL 60950-1 Recognized  
 UL 1310 Class 2 power (91.2W model only)  
 TUV ..... EN 60950-1  
 EN 61558-1, EN 61558-2-17  
 CE..... EN 61000-6-3, EN 55022 class B  
 EN 61000-3-2, EN 61000-3-3  
 EN 61000-6-2, EN 55024  
 EN 61000-4-2, -3, -4, -5, -6, -8, -11  
 EN 61204-3