



SMART Safety System

RFID sensor SRF | Emergency-stop SEU | Safety evaluation SCR DI

The innovative safety system for the intelligent factory of the future

Industry 4.0 in machine safety

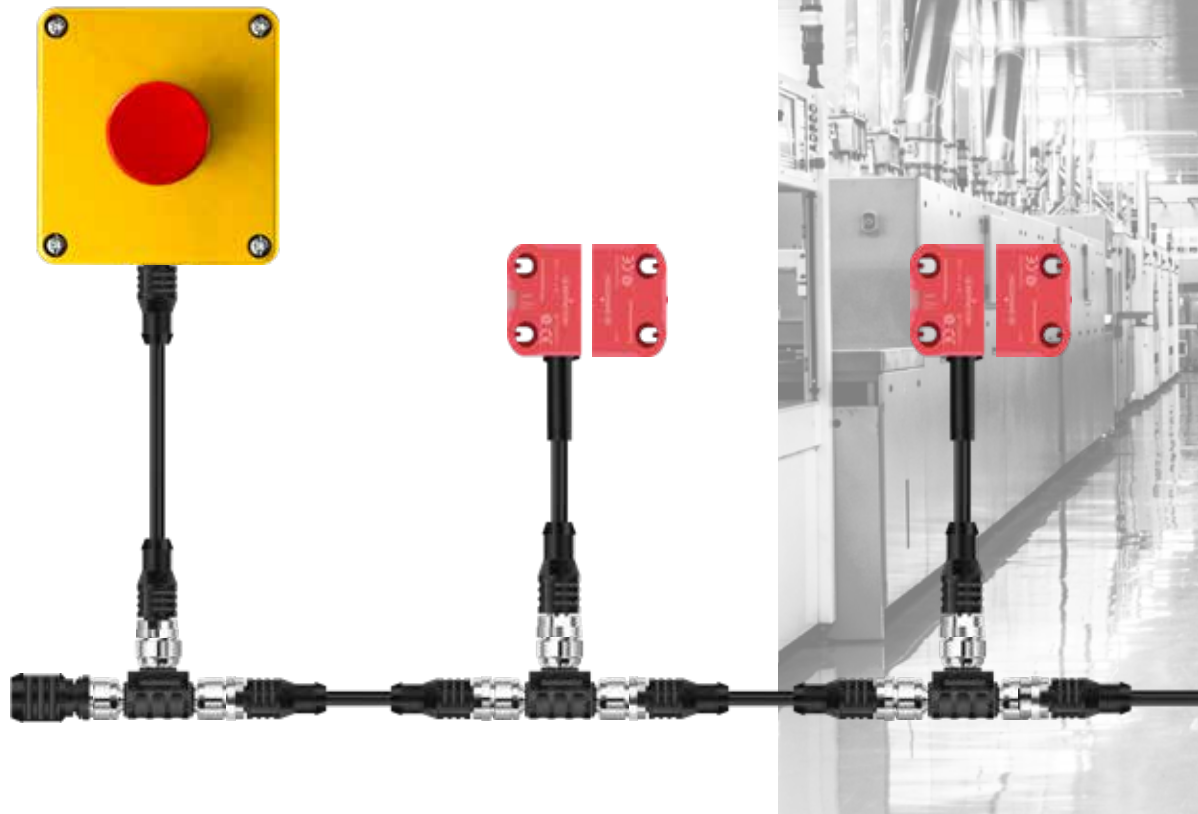

The SMART Safety System

Complete safety system with SMART diagnostic

Based on the SRF safety sensor, BERNSTEIN AG is expanding its product portfolio into a Smart Safety System. The various possible combinations of the products enable a wide range of solutions to safeguard a machine.

SRF | Emergency-stop SEU | Safety controller SCR DI

The SRF (Safety RFID) is a non-contact safety sensor to monitor movable guards such as flaps, doors and protective hoods. The small sensor protects operators from injury by switching off machines and by preventing them from being switched on again as long as the guard is not properly closed.

The Safety Emergency Unit (SEU) – the electronic emergency stop – can be easily integrated into the existing SRF safety chain thanks to the M12 connection. The requirement of the Machinery Directive, according to which every machine must be equipped with an emergency stop, is thus easily met. The problem of fault masking also no longer exists thanks to the electronics used.

The safety relay (SCR DI) combines three devices in one: It is a safety controller for the OSSD outputs of the sensor chain (SRF and SEU), a diagnostic module and an IO-Link gateway. It can safely monitor a series connection consisting of SRF and/or SEU and provides the diagnostic data.



With the integrated diagnostic channel, all (non-safety) relevant status information of the connected sensors (SRF-5) and emergency stop devices (SEU) is transmitted to the machine control via a diagnostic device or the safe controller SCR DI – even in a series connection. In addition, the SCR DI provides its own diagnostic data. Three redundant, safe relays allow direct switching of loads with up to 6 A per enabling path.

The entire system provides a wide range of data that enables simple and cost-saving predictive maintenance from early fault detection. These are made available via the DCD system, this transmits data to the controller, or alternatively displays it on a smartphone. In this way, a potentially very costly system shutdown can be avoided.

Innovative

- New innovative Daisy Chain Diagnostics (DCD)
- Retrieving the diagnostic information with an Android Smartphone via NFC Interface or per USB port
- Data transmission via IO-Link interface
- Simple and specific maintenance thanks to pre-failure monitoring
- Cost reduction through reduced machine downtime
- Support of an energy-optimized application (Voltage level is known and can be optimised at any time)

Diagnostic system DCD

The Daisy Chain Diagnostic System (DCD) provides a wealth of information to make the machines more efficient by avoiding downtime.

The DCD system is supported by the sensors (SRF-5), the emergency stop (SEU) and the safety relay (SCR DI). The data of each device are collected in the SCR DI (or stand-alone diagnostic device) and can be sent via ...

- IO-Link to a control system
- USB to a laptop
- NFC to an Android smartphone

Depending on the device, different data are available:

Information	Sensors SRF-5	Emergency stop and Connection box SEU	SCR DI
Actuator detected	x		
Falscher Betätiger	x		
Actuator code not reached in	x		
Actuator at the edge of the detection range	x		
Safety input 1	x	x	x
Safety input 2	x	x	x
Safety output 1	x	x	
Safety output 2	x	x	
Safety contact input 1		x	
Safety contact input 2		x	
Local reset expected	x	x	x
Operating voltage warning	x	x	
Operating voltage 24 V	x	x	x
Status Safe relay output			x
Status internal feedback loop			x
Status external feedback loop			x
Sensor functions	x		x
Number of remaining actuator teach-in operations	x		
Received actuator code	x		
Saved actuator code	x		
Time Actuator in detection limit	x		
Output fault Switch-off time	x	x	x
Operating voltage warning	x	x	x
Device temperature	x	x	
Current supply voltage	x	x	x
Actuator distance	x		
Switching cycles internal relay			x
Switching cycles relay output			x
Order number of the SCR DI			x

All the diagnostic information are not safety-relevant!

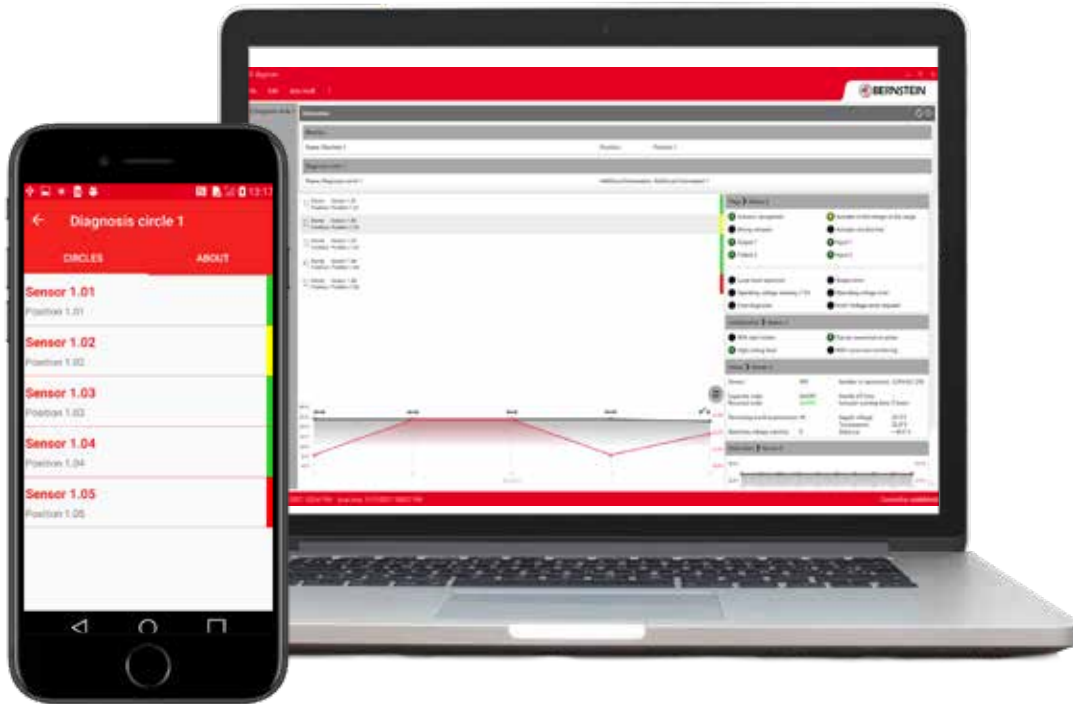

In order to simplify the assignment of information, it is possible to permanently assign a name and descriptive text to each device, safety chain and machine, making it easier for the user to identify the corresponding device.

In addition, there is a fault memory that stores typical fault data to simplify the search.



To download the necessary software.

Diagnostic data of the fault memory

here at the example of a SRF-5

Information	Meaning
Operating voltage 24V	Operating voltage outside specification (24 V +/- 20 %)
Wrong actuator	Actuator code OK/ Actuator code not OK
Actuator at the edge of the detection area	Actuator distance OK / actuator at the edge of the detection area
Status safety output 1	On / Off
Status safety output 2	On / Off

The error messages are stored in the diagnostics module using a time stamp and can be retrieved via all interfaces if needed. Thanks to the NFC function, this information can be read even if there is no voltage on the diagnostic module. This unique feature allows efficient troubleshooting and accelerates restart of defective machines.

The SRF

Benefits and features



reddot award 2018
winner

- **Cost-saving** thanks to a four-wire unshielded standard connection cable from sensor to sensor ①
- **Compact and flexible** in application thanks to small design
- **Safe up to PL e** even in series connection, with high defeat protection (according to ISO 14119)

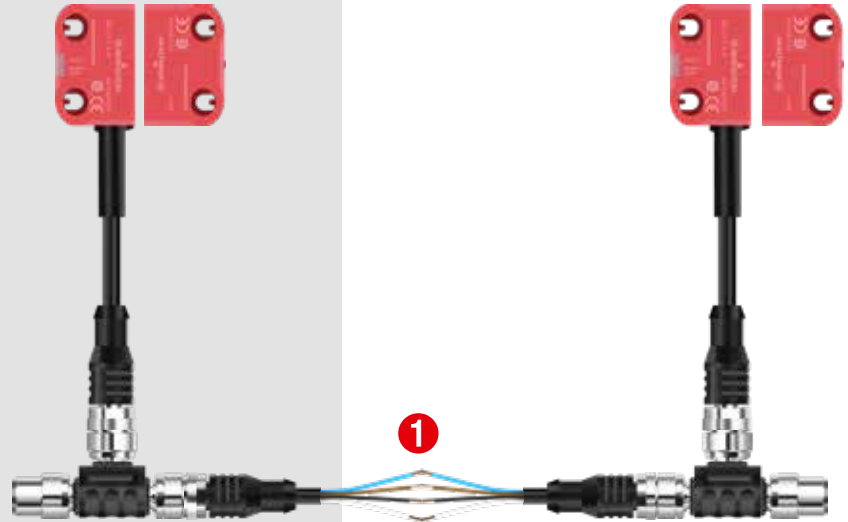

Coding types

- **Low coding level:**
Sensor accepts any SRF actuator; no teach-in procedure.
- **High coding level:**
Sensor accepts taught-in SRF actuators only; an SRF actuators can be taught-in up to 12 times.
- **Unique coding:**
An SRF actuator can only be taught-in once.

Diagnostics (not safety related)

- **PNP diagnostics:**
Signalling contact as PNP signal indicating whether the safety guard is closed.
- **DCD System:**
Detailed diagnostic system DCD that submits a complete status image of a sensor, even in series connection.

Reset function

Local reset of the sensor to enable restart of the machine.

Fault tolerant outputs

The fault tolerant outputs prevent an unexpected machine stop and allow to run down the machine in a controlled manner.

This is how it works:

If an error is detected at one output, the sensor indicates this with a flash code – whilst simultaneously transmitting the information via the DCD system. After 20 minutes, the second still intact output, will switch off.

Intelligent sensor inputs

The status of the safety inputs is checked for plausibility and prevents the system from being switched on again in the event of a fault. This makes it possible to integrate mechanical contacts into the series connection, taking the TR 24119 into account.

Safety Controller SCR DI with IO-Link



- Safety monitoring module for OSSD signals
- Simple and fast retrieval of diagnostic information via smartphone with NFC
- Time and cost savings during commissioning, maintenance and troubleshooting
- Transmission of DCD diagnostic data via IO-Link
- Three devices combined in one:
 - Diagnostic device
 - Safety controller
 - IO-Link device



Features

- Safety monitoring, diagnostics and IO-Link communication in one device
- Saves space in the control cabinet thanks to slim design
- Provides all relevant information of each device in the chain and delivers available data
- Permanent exchange of all data
- Three enabling paths
- Category 4 / PL e according to EN ISO 13849-1

Article number	Designation	Enabling paths	Signalling contact Feedback loop	Digital outputs	Automatic/ manual reset	Interfaces		
						IO-link	NFC	USB 2.0
6075113139	SCR DI-1/0/3-T	3	1	-	Auto/button	x	-	-
6075113140	SCR DI-1/8/3-T	3	1	8	Auto/button	x	-	-
6075113141	SCR DI-1/0/1-T	3	1	-	Auto/button	x	x	x

Emergency stop and connection box for direct integration into an SRF sensor chain



The Emergency stop

The emergency stop offers an optical status display via LED as well as the transmission of the device status via DCD diagnostic to the machine control system. To reset after activating simply rotate the button.

Features of the emergency stop

- Simple integration of the emergency stop into the sensor chain via M12 plug connection
- Diagnostic information of every emergency stop device available
- Identification of whether the switch-off signal is caused by the emergency stop or by a sensor
- Monitoring of compliance with test cycles for emergency stop simply possible
- TR 24119 (fault masking) doesn't have to be considered
- Saves an input of a fail-safe PLC or an entire safety relay

Article number	Designation	Description
6075689138	SEU-2/0-P80-C	Emergency stop switch



The connection box

With the SEU connection box, existing electromechanical safety switches, such as safety interlocks or emergency stop devices, can be integrated into the SRF safety chain with ease. In addition, mechanical switches with the connection box can be integrated into the sensor chain. The status data are also transmitted to the connection box via DCD diagnosis.

Features of the connection box

- Easy integration of electromechanical safety switches into the sensor chain via the connection box via M12 plug connection
- Diagnostic information of each connected safety switch available
- Saving of a safe input or a safety relay by integration into the sensor chain



Article number	Designation	Description
6075689137	SEU-1/0-M64-C	Connection box

SRF

Series connection

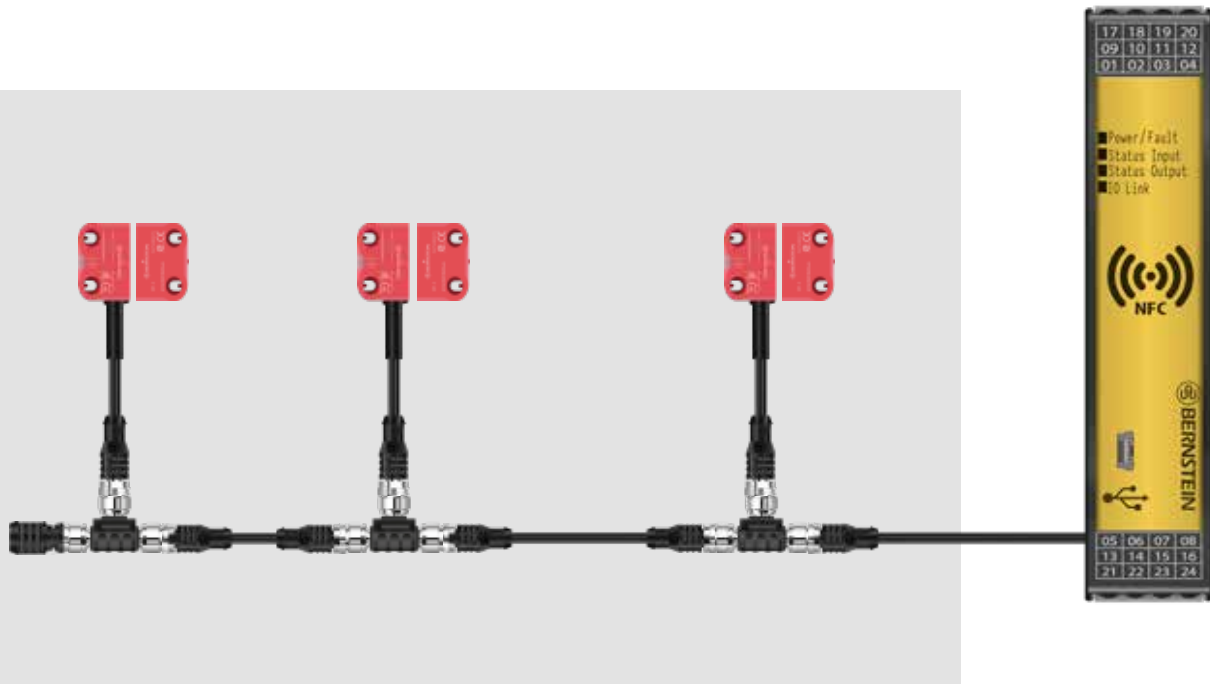

Article number	Designation	Unique coding level	High coding level	Low coding level	PNP diagnostics	Daisy Chain diagnostics (DCD)	Reset input	M12 8-pin connection with 25 cm cable	M8 8-pin connection with 25 cm cable
6075685094	SRF-4/1/1-E0,25-U	x			x			x	
6075685095	SRF-4/1/1-E0,25-H		x		x			x	
6075685096	SRF-4/1/1-E0,25-L			x	x			x	
6075685097	SRF-4/2/1-E0,25-U	x			x		x	x	
6075685098	SRF-4/2/1-E0,25-H		x		x		x	x	
6075685099	SRF-4/2/1-E0,25-L			x	x		x	x	
6075685100	SRF-5/1/1-E0,25-U	x				x		x	
6075685101	SRF-5/1/1-E0,25-H		x			x		x	
6075685102	SRF-5/1/1-E0,25-L			x		x		x	
6075685080	SRF-5/2/1-E0,25-U	x				x	x	x	
6075685103	SRF-5/2/1-E0,25-H		x			x	x	x	
6075685104	SRF-5/2/1-E0,25-L			x		x	x	x	
6075685112	SRF-5/1/1-D0,25-H		x			x			x
6075685113	SRF-5/1/1-D0,25-L			x		x			x
6075687078	SRF-0	Actuator SRF, suitable for all coding levels *							
6075687144	SRF-0-18	Actuator SRF (rectangular design), suitable for all coding levels*							

* The actuators are not included in delivery - please order separately!

SRF

Single connection

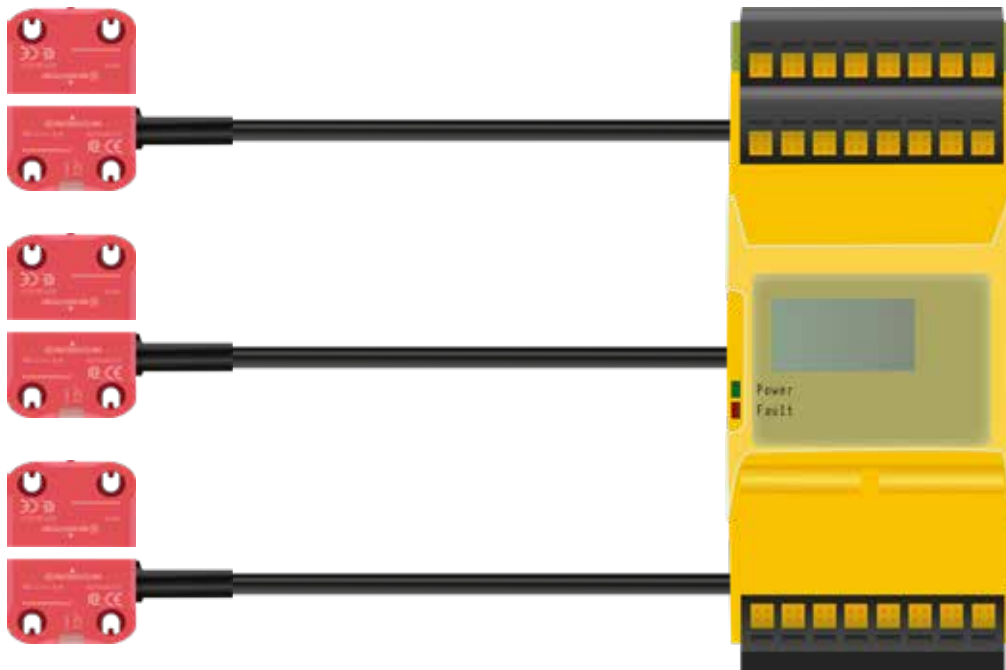

Article number	Designation	Unique	High coding level	Low coding level	PNP diagnostics	M12 5-pin connection with 25 cm cable	2 m cable with open cable end	M8 8-pin connection with 25 cm cable
6075685117	SRF-2/1/1-A2-U	x			x		x	
6075685079	SRF-2/1/1-A2-H		x		x		x	
6075685118	SRF-2/1/1-A2-L			x	x		x	
6075685119	SRF-2/1/1-E0,25-U	x			x	x		
6075685120	SRF-2/1/1-E0,25-H		x		x	x		
6075685121	SRF-2/1/1-E0,25-L			x	x	x		
6075685142	SRF-2/1/1-D0,25-H		x		x			x
6075687078	SRF-0	Actuator SRF, suitable for all coding levels *						
6075687144	SRF-0-18	Actuator SRF (rectangular design), suitable for all coding levels*						

* The actuators are not included in delivery - please order separately!

Diagnostic module



Article number	Designation	Enclosures	Number of diagnostic circuits	Digital outputs	Interfaces		
					IO-Link	NFC	USB 2.0
6075619122	SRF DI-C-0/1-T	DIN rail housing 22.5 mm	1	-	x	x	x
6075619123	SRF DI-C-8/1-T	DIN rail housing 22.5 mm	1	8	x	x	x
6075619124	SRF DI-C-16/1-T	DIN rail housing 22.5 mm	1	16	x	x	x
6075619125	SRF DI6-C-0/1-T	DIN rail housing 22.5 mm	6	-	x	x	x
6075689126	SRF DI-F-0/2-E0,25	Rectangular sensor enclosure (field device)	1	-	x	x	



Connection cable and connecting cable

Pos.-Nr.	Article number	Designation	Description	Plug alignment	Plug 1	Plug 2	Number of plugs	Cable length in meter
1	6075689085	S1W-M12A8/BW-1PU	Connection cable	straight	M	F	8	1
1	6075689086	S1W-M12A8/BW-2PU	Connection cable	straight	M	F	8	2
2	6075689087	S1W-M12C4/AW-2PU	Connection cable	straight	M	F	4	2
2	6075689088	S1W-M12C4/AW-5PU	Connection cable	straight	M	F	4	5
2	6075689089	S1W-M12C4/AW-10PU	Connection cable	straight	M	F	4	10
3	6075689092	SFW-M12B5/AW-2PU	Connection cable (flying leads)	straight	F		5	2
3	6075689093	SFW-M12B5/AW-5PU	Connection cable (flying leads)	straight	F		5	5
3	6075689090	SFW-M12C4/AW-0,5PU	Connection cable (flying leads)	straight	F		4	0,5
3	6075689091	SFW-M12C4/AW-2PU	Connection cable (flying leads)	straight	F		4	2

T-adapter, termination plug and fixing screws

Pos.-Nr.	Article number	Designation	Description
4	6075989082	ATS-M12/4-M12/8	T-adapter for series connection of sensors
5	6075989083	ATD-M12/8-M12/4	T-adapter for IO-Link connection and reset button
6	6075689084	AEP-M12/4	Termination plug M12
	6075689127	AT-CLIP-M12	fixing clip for T-adapter
	6075689128	One-way-screw M4 × 16	10 × fixing screws M4 × 16 one-way-screw

Technical data

SRF

SRF-0

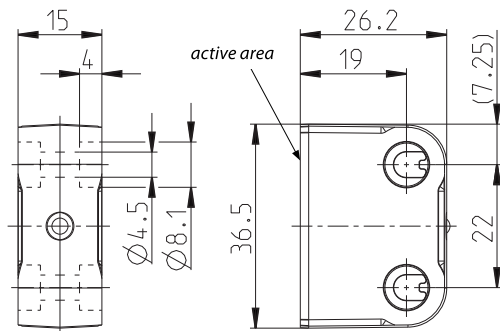

SRF-0-18

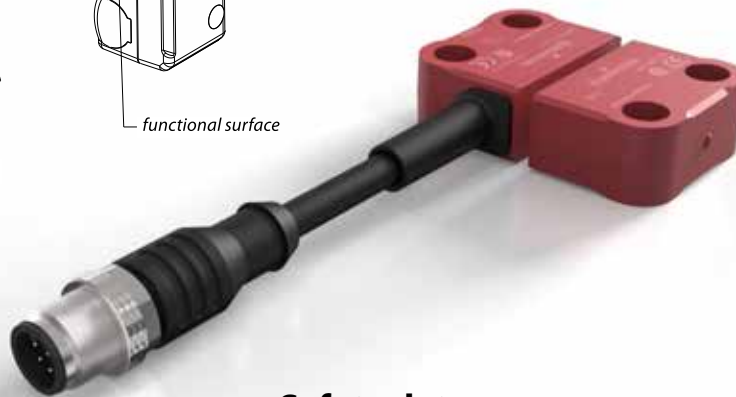
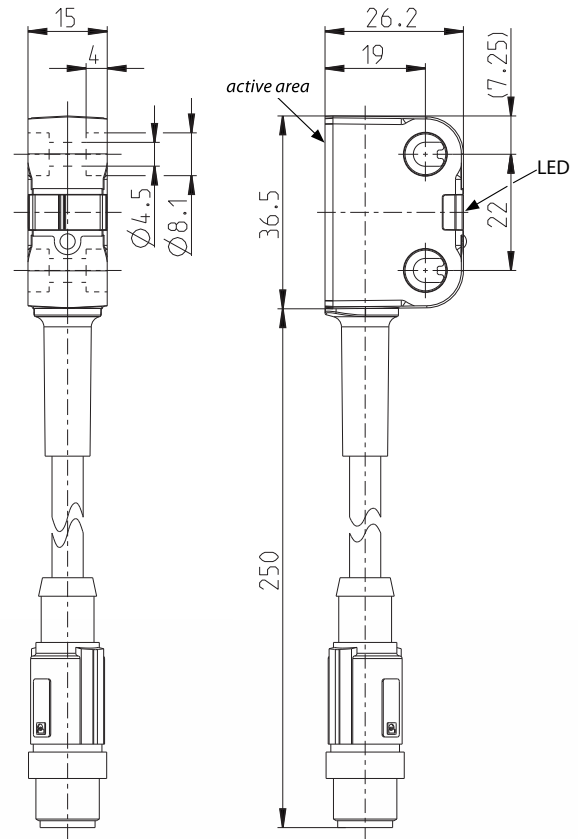
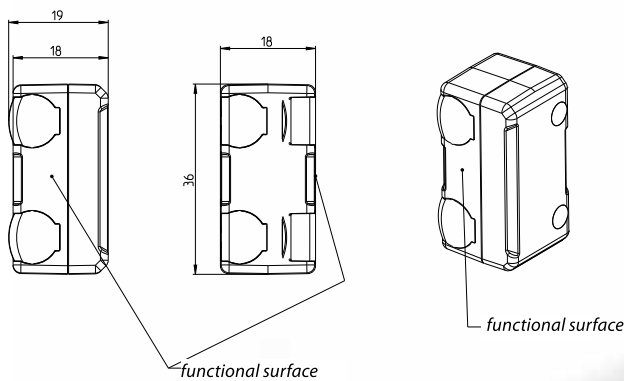

Electrical data

- Rated operational voltage U_e : 24 V DC
- Output current of the signal output I_e : 10 mA
- Output current of the safety outputs I_e : 100 mA

Mechanical data

- Enclosure: PA66 + PA6, red, self-extinguishing
- Connection cable: PUR
- Mounting holes: $\varnothing 4,5$ (für M4 screws)
- Displays: 1 \times LED red/green operating status
1 \times LED yellow actuation status
- Ambient temperature: -25°C to $+70^\circ\text{C}$
- Protection class: IP69

Safety data

- PL e / Cat. 4 (according to EN ISO 13849-1)
- SIL CL 3 (according to DIN EN 62061)
- $\text{PFH}_D = 6 \times 10^{-9}$ 1/h
- Mission time T_M : 20 years
- Switching distance
 - Rated operating distance S_n : 13 mm
 - Assured switching distance – On S_{ao} : 10 mm
 - Assured switching distance – Off S_{ar} : 25 mm
 - Hysteresis: 2 mm
- Switch-off delay t_d : max. 100 ms + 7 ms/add. sensor
- Ready delay t_r : max. 2 s

Technical data

Diagnostic modules

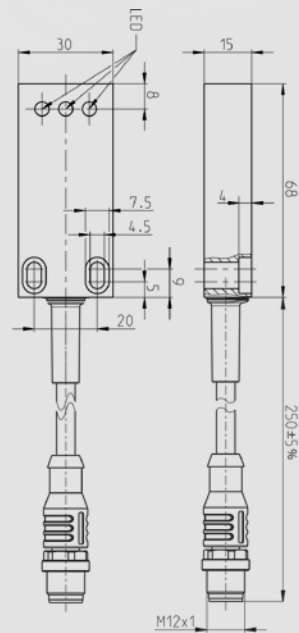
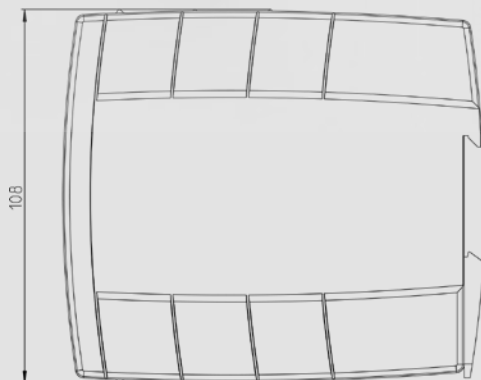

Cabinet module

- Rated operational voltage U_e : 24 V DC
- IO-Link protocol: V1.1
- Output current per signal output I_e : 50 mA
- Ambient temperature: 0 °C bis +60 °C
- Protection class: IP20

Field module

- Rated operational voltage U_e : 24 V DC
- IO-Link protocol: V1.1
- Ambient temperature: -25 °C to +70 °C
- Protection class: IP69

Technical data

Emergency stop and Connection box

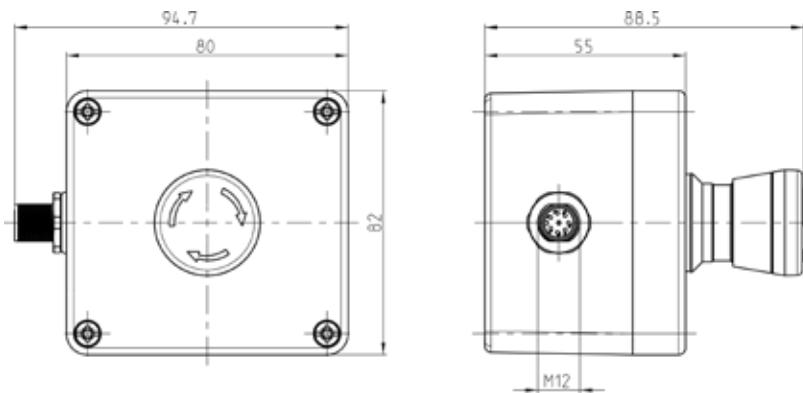

Emergency-stop button

Electrical data

- Rated operational voltage U_e : 24 V DC
- Output current of the message output I_e : 10 mA
- Output current of the safety outputs I_e : 100 mA

Mechanical data

- Enclosure material: Polycarbonate
- Ambient temperature: -25 °C to +70 °C
- Protection class: IP65

Safety data

- up to PL e / Cat. 4 (according to EN ISO 13849-1)
- up to SIL CL 3 (according to DIN EN 62061)

Connection box

Electrical data

- Rated operational voltage U_e : 24 V DC
- Output current of the message output I_e : 10 mA
- Output current of the safety outputs I_e : 100 mA

Mechanical data

- Enclosure material: Die-cast aluminium
- Ambient temperature: -25 °C to +70 °C
- Protection class: IP67

Safety data

- up to PL e / Cat. 4 (according to EN ISO 13849-1)
- up to SIL CL 3 (according to DIN EN 62061)

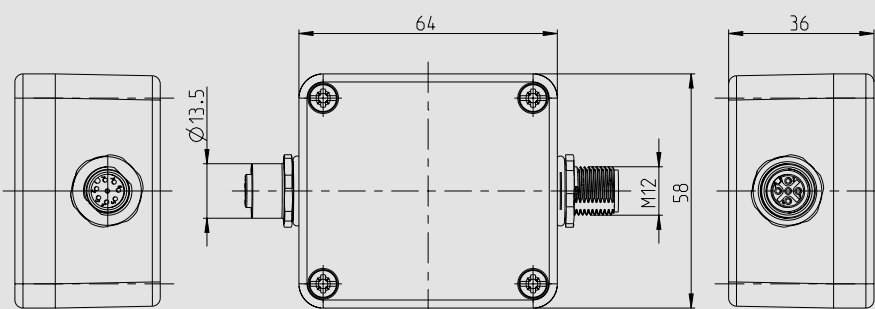

Technical data

SCR DI

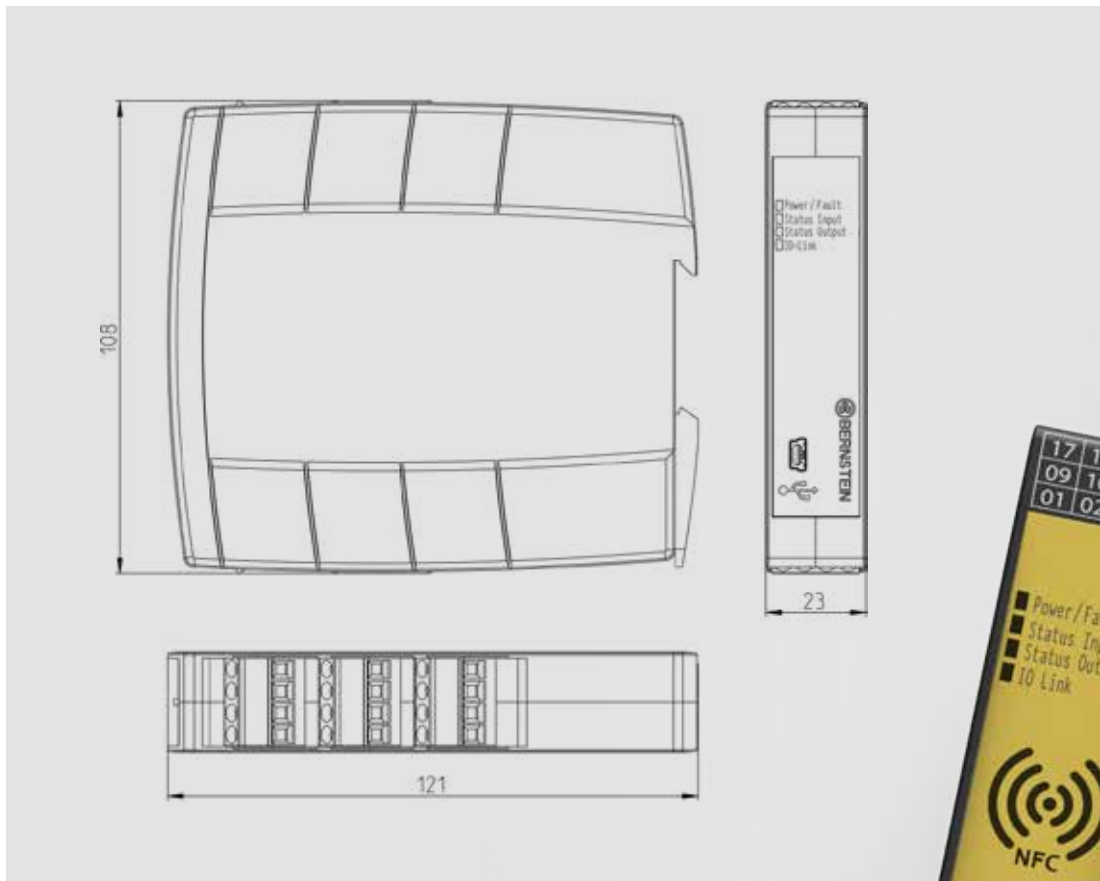

Product information

- Dimensions (mm): 108 × 22,5 × 121 (W × H × D)
- IO-Link protocol: V1.1
- For semiconductor outputs BERNSTEIN SMART Safety System

Electrical data

- Rated operational voltage U_e : 24 V DC
- Three enabling paths with up to 6A switching current per path

Mechanical data

- Enclosure material: Glass fibre reinforced polyamide PA-GF
- Ambient temperature: 0°C to +60°C
- Protection class: IP20

Notes

Diagrams. Sketches. Ideas.

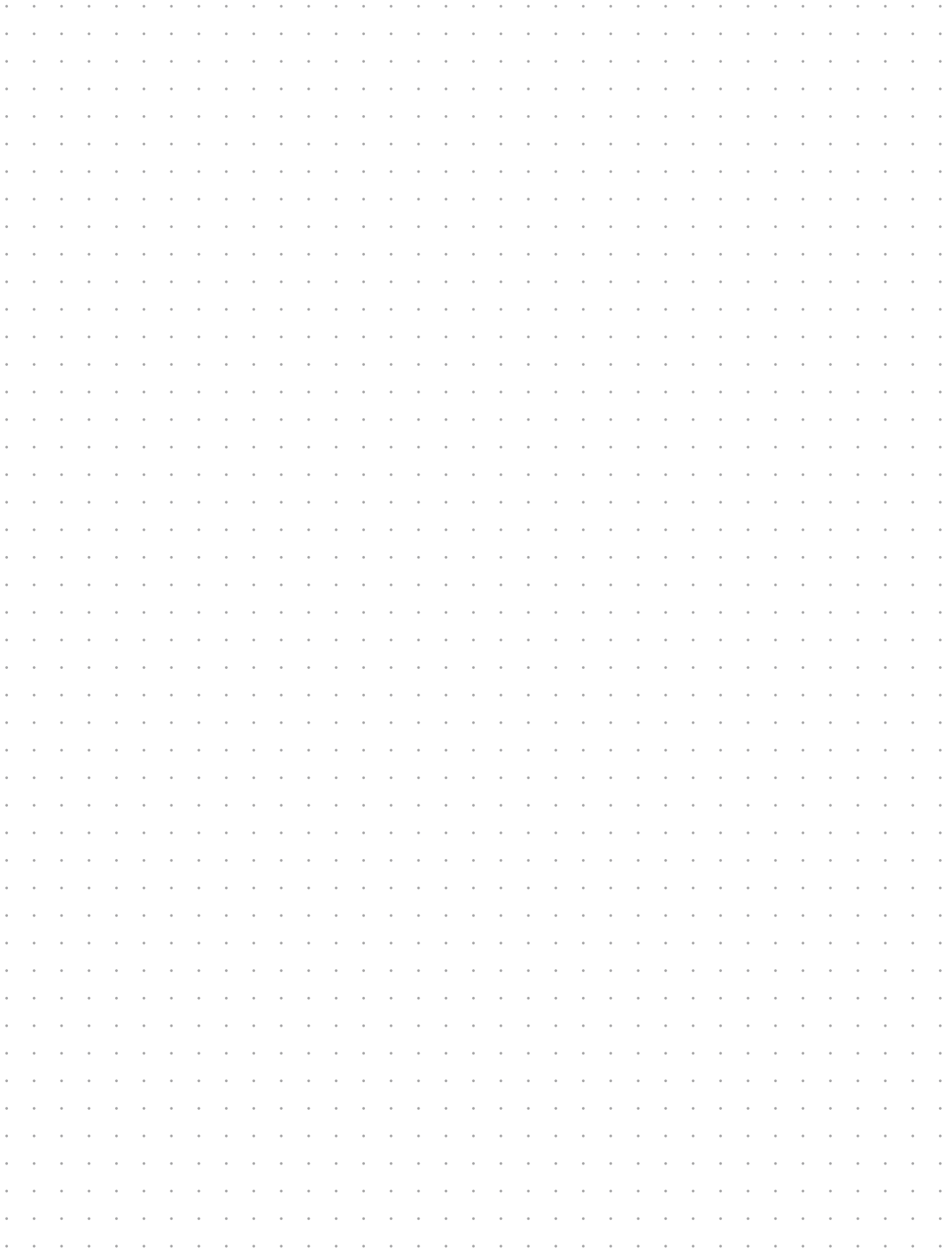

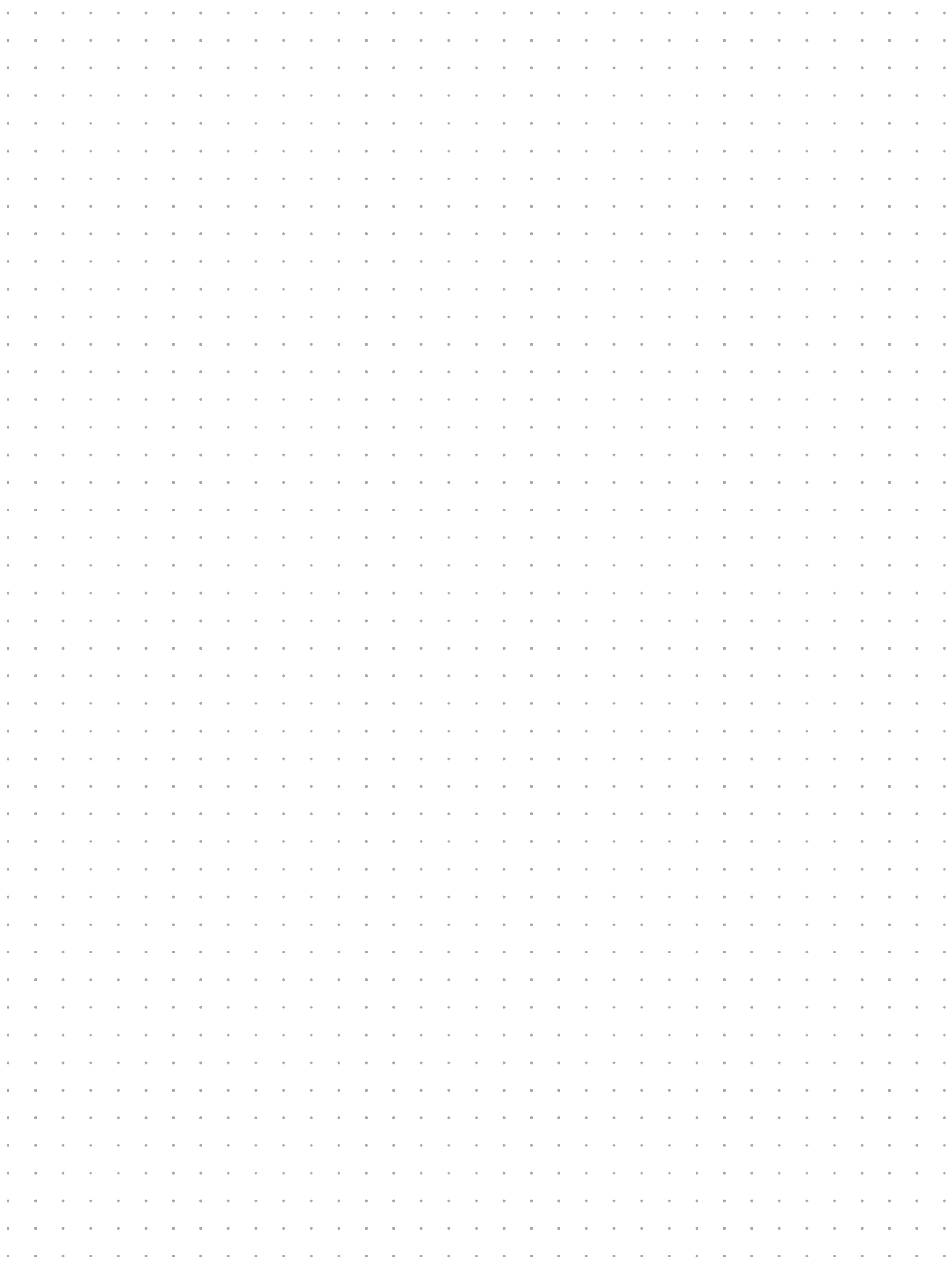



Contact

International Headquarters BERNSTEIN AG

Hans-Bernstein-Str. 1
D-32457 Porta Westfalica
Phone +49 571 793-0
Fax +49 571 793-555
info@de.bernstein.eu
www.bernstein.eu

Denmark BERNSTEIN A/S

Phone +45 7020 0522
Fax +45 7020 0177
info@dk.bernstein.eu

France BERNSTEIN S.A.R.L.

Phone +33 1 64 66 32 50
Fax +33 1 64 66 10 02
info@fr.bernstein.eu

Italy BERNSTEIN S.r.l.

Phone +39 035 4549037
Fax +39 035 4549647
info@it.bernstein.eu

United Kingdom BERNSTEIN Ltd

Phone +44 1922 744999
Fax +44 1922 457555
info@uk.bernstein.eu

Austria BERNSTEIN GmbH

Phone +43 2256 62070-0
Fax +43 2256 62618
info@at.bernstein.eu

Switzerland BERNSTEIN (Schweiz) AG

Phone +41 44 775 71-71
Fax +41 44 775 71-72
info@ch.bernstein.eu

Hungary BERNSTEIN Kft.

Phone +36 1 4342295
Fax +36 1 4342299
info@hu.bernstein.eu

China BERNSTEIN Safe Solutions

(Taicang) Co., Ltd.
Phone +86 512 81608180
Fax +86 512 81608181
info@bernstein-safesolutions.cn