

PEPPERL+FUCHS BEBCO EPS®

6000 SERIES PURGE AND PRESSURIZATION SYSTEM



# FEATURES

## YOUR BENEFITS

A single solution for all applications

- Globally certified for use in North America, Europe, and Asia
- Universal design makes it easy to specify, install, and operate

Easy programming and operation

- User-friendly interface with menu-driven programming
- Automatic purge and pressurization and temperature control

Flexible and rugged construction

- Durable construction withstands harsh elements
- Universal mounting for control unit and vent

## COMPONENT KIT

The 6000 Series is available as a stand-alone kit, so that an enclosure can be retrofitted or modified with a purge system. The kits include the key components for the purge system: the control unit with explosion-proof enclosure and a user interface.



Explosion-proof enclosure



User interface



Manifold

## COMPONENT KIT ACCESSORIES



Dustproof enclosure

The dustproof enclosure and I.S. termination board are accessories that complement the functionality of the component kits.



Temperature hub and sensor

Powers up to three external Pepperl+Fuchs temperature sensors to monitor and control the enclosure temperature.

# PEPPERL+FUCHS 6000 SERIES – THE MOST ADVANCED PURGE AND PRESSURIZATION SYSTEM IN THE INDUSTRY

## 6000 SERIES OVERVIEW

The days of self-made purge and pressurization solutions and cumbersome configuration are over. The 6000 Series is the most advanced purge/pressurization system ever and can handle just about any application challenge. This new series has a stainless steel housing that contains the controller, pneumatics, electrical I/O, and programming interface. The programming screen allows easy setup and operation and lets the user program the system according to the requirements of the application. The screen also displays information such as flow, pressure, and system status. The pressure and flow feedback is provided to the control unit by the vent. With global certifications and a modern century design, the 6000 Series is the most advanced system on the market! Pepperl+Fuchs continues to be “The Leaders in Purging Technology®.”

## STANDARD MODEL APPLICATIONS

**Model Numbers:** 6000 Type X & Ex px  
**Designation:** Rapid Exchange® purging systems  
**Enclosure Volume:** 7.1 m<sup>3</sup> / 250 ft<sup>3</sup> max.  
**Approvals:** See our website

Suitable for Class I and II, Division 1/ Zone 1 and Zone 21 to non-hazardous area applications according to:

- North American NFPA 486
- European ATEX
- International IECEx approvals



# TYPE X & Ex px

## 6000 SERIES CONTROL UNIT



## EPV-6000 VENT

One vent is able to work for all enclosure sizes.

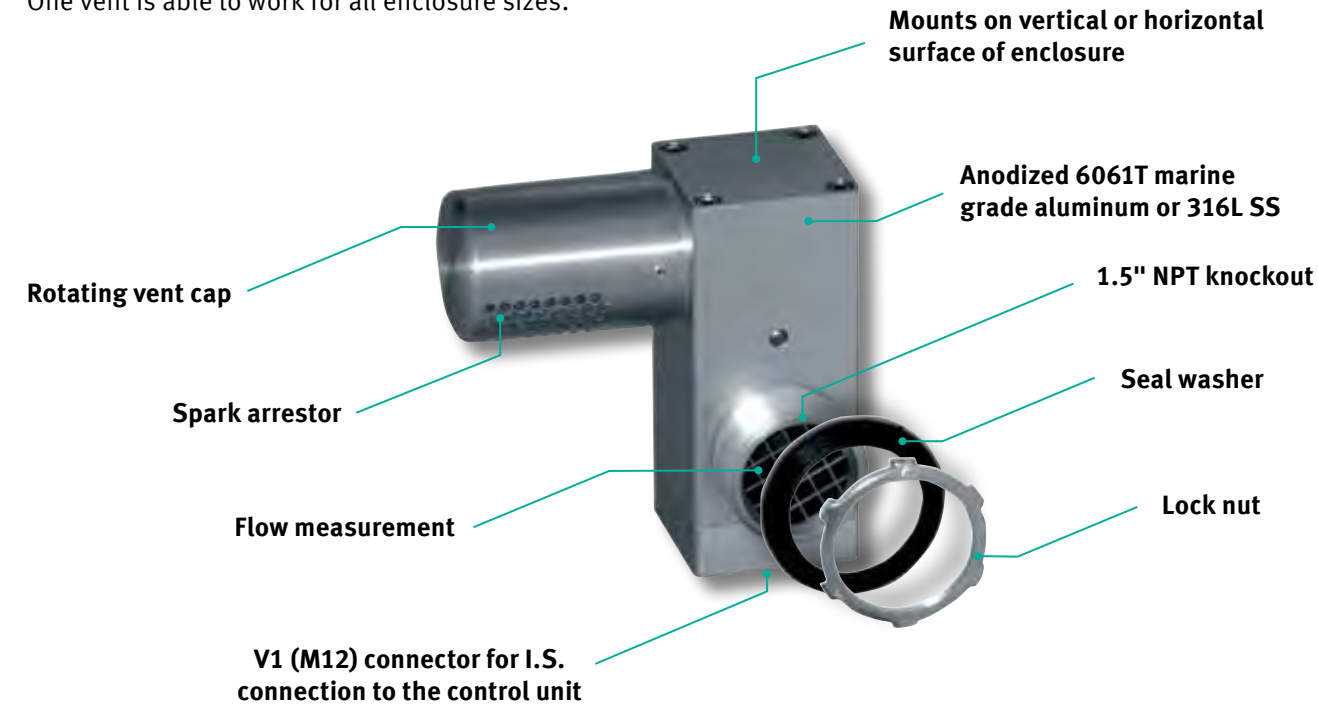

## MOUNTING OPTIONS

The control unit and vent can be mounted in any orientation—vent can be mounted inside enclosure with vent cap on outside.

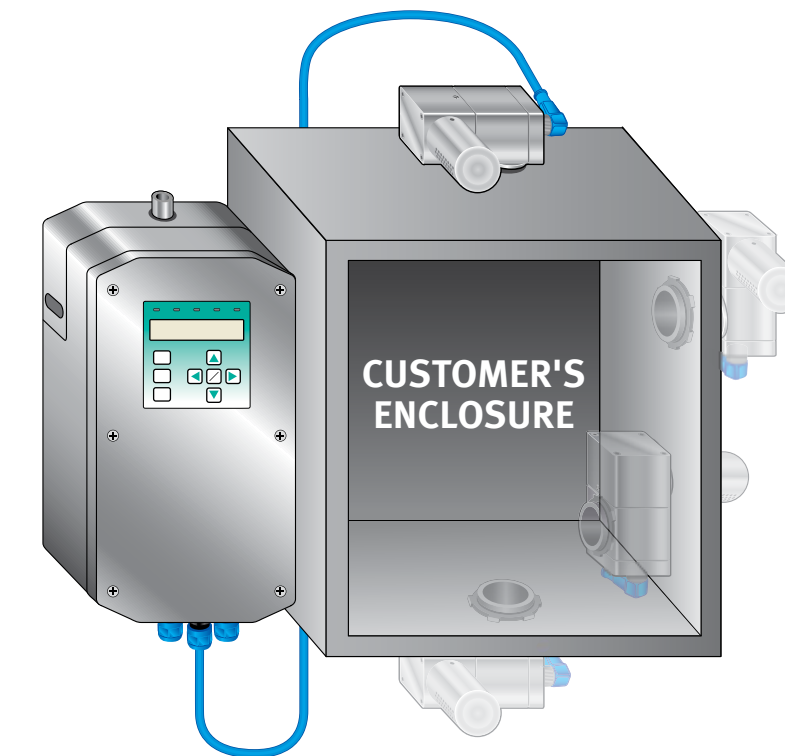

Purge and pressurization protection is suitable for many applications and is one of the most flexible Ex protection solutions. The BebcO EPS® systems by Pepperl+Fuchs provide the means to operate general-purpose equipment in classified areas or in environments that are highly corrosive or dusty. The principle behind purge and pressurization systems is to prevent a corrosive, dusty, or potentially explosive atmosphere from penetrating a closed protective housing using a standard overpressure technology. With a complete range of solutions for both Zone and Division applications, Pepperl+Fuchs offers the expertise and solutions to satisfy the safety and operational requirements for today's process automation environments.

For more information about our complete line of purge and pressurization solutions, visit [www.pepperl-fuchs.us](http://www.pepperl-fuchs.us).

## TYPICAL APPLICATIONS



The 6000 Series' rugged housing is designed to withstand harsh and corrosive environments.



Pepperl+Fuchs purge and pressurization systems support a wide range of cabinet enclosure solutions.



In hazardous locations, where flammable vapors, gases, and dust are present, Pepperl+Fuchs 6000 Series helps prevent plant explosions.

# PROCESS AUTOMATION – PROTECTING YOUR PROCESS



For over a half century, Pepperl+Fuchs has provided new concepts for the world of process automation. Our company sets standards in quality and innovative technology. We develop, produce and distribute electronic interface modules, Human-Machine Interfaces and hazardous location protection equipment on a global scale, meeting the most demanding needs of industry. Our worldwide presence, combined with flexible operating systems in our production and service organizations, enable us to offer complete individual solutions – wherever and whenever you need us. We are the recognized experts in our technologies – Pepperl+Fuchs has earned a strong reputation by supplying the world's largest process industry companies with the broadest line of proven components for a diverse range of applications.

## 1 Worldwide/German Headquarters

Pepperl+Fuchs GmbH  
Mannheim · Germany  
Tel. +49 621 776 2222  
E-Mail: [pa-info@de.pepperl-fuchs.com](mailto:pa-info@de.pepperl-fuchs.com)

## 2 Asia Pacific Headquarters

Pepperl+Fuchs PTE Ltd.  
Singapore  
Company Registration No. 199003130E  
Tel. +65 6779 9091  
E-Mail: [pa-info@sg.pepperl-fuchs.com](mailto:pa-info@sg.pepperl-fuchs.com)

## 3 Central/Western Europe & Africa Headquarters

Pepperl+Fuchs N.V.  
Schoten/Antwerp · Belgium  
Tel. +32 3 6442500  
E-Mail: [pa-info@be.pepperl-fuchs.com](mailto:pa-info@be.pepperl-fuchs.com)

## 4 Middle East Headquarters

Pepperl+Fuchs M.E (FZE)  
Dubai · UAE  
Tel. +971 4 883 8378  
E-Mail: [pa-info@ae.pepperl-fuchs.com](mailto:pa-info@ae.pepperl-fuchs.com)

## 5 North/Central America Headquarters

Pepperl+Fuchs Inc.  
Twinsburg · Ohio · USA  
Tel. +1 330 486 0002  
E-Mail: [pa-info@us.pepperl-fuchs.com](mailto:pa-info@us.pepperl-fuchs.com)

## 6 Northern Europe Headquarters

Pepperl+Fuchs GB Ltd.  
Oldham · England  
Tel. +44 161 6336431  
E-Mail: [pa-info@gb.pepperl-fuchs.com](mailto:pa-info@gb.pepperl-fuchs.com)

## 7 Southern/Eastern Europe Headquarters

Pepperl+Fuchs Elcon srl  
Sulbiate · Italy  
Tel. +39 039 62921  
E-Mail: [pa-info@it.pepperl-fuchs.com](mailto:pa-info@it.pepperl-fuchs.com)

## 8 South America Headquarters

Pepperl+Fuchs Ltda.  
São Bernado do Campo · SP · Brazil  
Tel. +55 11 4341 8448  
E-Mail: [pa-info@br.pepperl-fuchs.com](mailto:pa-info@br.pepperl-fuchs.com)

[www.pepperl-fuchs.com](http://www.pepperl-fuchs.com)

 **PEPPERL+FUCHS**  
PROTECTING YOUR PROCESS