

**Diffuse contrast sensors**

**OZDK 14 (Laser)**

**sample drawing**

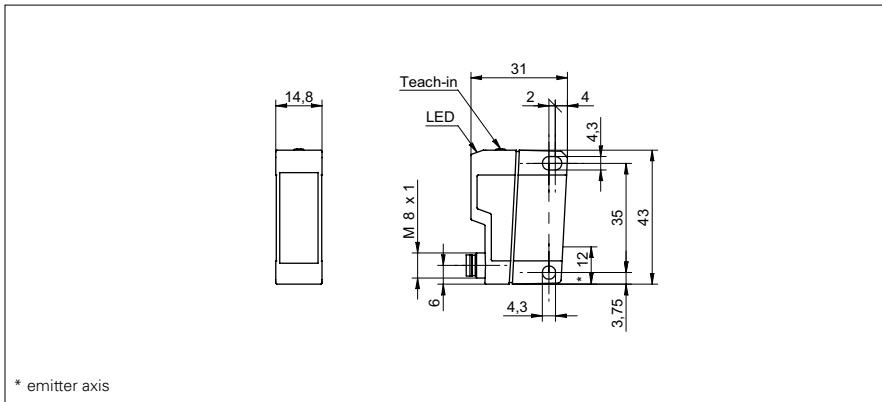

\* emitter axis

**general data**

type	diffuse contrast sensor
light source	pulsed red laser diode
sensing distance Tw	20 ... 300 mm
optimum operating distance	40 ... 60 mm
repeat accuracy	< 0,2 mm at laser focus
alignment / soiled lens indicator	flashing light indicator
power on indication	LED green
light indicator	LED yellow
sensitivity adjustment	Teach-in
laser class	2
distance to focus	115 mm
wave length	650 nm

**electrical data**

response time / release time	< 0,15 ms
voltage supply range +Vs	10 ... 30 VDC
current consumption max. (no load)	35 mA
current consumption typ.	25 mA
voltage drop Vd	< 2,2 VDC
output function	light operate
output current	< 100 mA
short circuit protection	yes
reverse polarity protection	yes

**mechanical data**

width / diameter	14,8 mm
height / length	43 mm
depth	31 mm
type	rectangular
housing material	plastic (ASA, MABS)
front (optics)	PMMA

**ambient conditions**

operating temperature	-10 ... +50 °C
protection class	IP 67

**sample picture**



**laser warning**

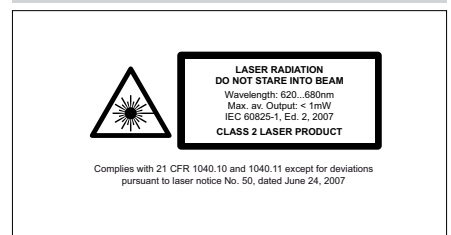

**Diffuse contrast sensors****OZDK 14 (Laser)**

<b>order reference</b>	<b>connection types</b>	<b>output circuit</b>
<b>OZDK 14N1901/S14</b>	connector M12 4 pin	NPN
<b>OZDK 14P1901</b>	cable 4 pin, 2 m	PNP
<b>OZDK 14P1901/S14</b>	connector M12 4 pin	PNP
<b>OZDK 14P1901/S35A</b>	connector M8 4 pin	PNP