

Incremental encoders

With blind or through hollow shaft

100...5000 pulses per revolution

EIL580 - hollow shaft - OptoPulse®



EIL580 with blind hollow shaft

Features

- Size \varnothing 58 mm
- Precise optical sensing
- Output signal level TTL or HTL
- Blind or through hollow shaft, \varnothing 8...15 mm
- Connection axial, radial or tangential
- Pulses per revolution up to 5000
- High protection up to IP 67
- High resistance to shock and vibrations

Technical data - electrical ratings

Voltage supply	5 VDC \pm 5 % 8...30 VDC 4.75...30 VDC
Reverse polarity protection	Yes
Short-circuit proof	Yes (HTL) Yes (TTL, max. 1 s and 1 signal)
Consumption w/o load	\leq 70 mA
Pulses per revolution	100...5000
Phase shift	$90^\circ \pm 10^\circ$
Scan ratio	40...60 %
Reference signal	Zero pulse, width $90^\circ \pm 10\%$
Sensing method	Optical
Output frequency	\leq 300 kHz (TTL) \leq 160 kHz (HTL)
Output signals	A+, B+, R+, A-, B-, R-
Output stages	TTL/RS422 HTL/push-pull
Interference immunity	DIN EN 61000-6-2
Emitted interference	DIN EN 61000-6-3
Approval	UL 508 / CSA 22.2

Technical data - mechanical design

Size (flange)	\varnothing 58 mm
Motor shaft tolerance	0.2 mm axial 0.03 mm radial
Protection DIN EN 60529	IP 65 (without shaft seal), IP 67 (with shaft seal)
Starting torque	\leq 0.02 Nm (+20 °C, IP 65) \leq 0.025 Nm (+20 °C, IP 67)
Materials	Housing: aluminium die-cast Flange: aluminium
Operating temperature	-40...+85 °C
Relative humidity	90 % non-condensing
Resistance	DIN EN 60068-2-6 Vibration 30 g, 10-2000 Hz DIN EN 60068-2-27 Shock 250 g, 6 ms
Connection	Flange connector M12, 8-pin Flange connector M23, 12-pin Cable
Weight approx.	300 g

EIL580 - blind hollow shaft

Shaft type	\varnothing 8...15 mm (blind hollow shaft)
Operating speed	\leq 6000 rpm (+20 °C, IP 67) \leq 8000 rpm (+20 °C, IP 65)

EIL580 - through hollow shaft

Shaft type	\varnothing 8...15 mm (through hollow shaft)
Operating speed	\leq 3000 rpm (+20 °C, IP 67) \leq 6000 rpm (+20 °C, IP 65)

Incremental encoders

With blind or through hollow shaft
100...5000 pulses per revolution

EIL580 - hollow shaft - *OptoPulse*®

Part number

Blind hollow shaft

EIL580- **B** **.A**

Pulse number - see table

Voltage supply / output stages

- E 5 VDC, TTL/RS422, 6 channel**
- H 8...30 VDC, TTL/RS422, 6 channel
- N 8...30 VDC, HTL/push-pull, 6 channel**
- Q 4.75...30 VDC, HTL/push-pull, 6 channel

Connection

- R Cable radial, 1 m**
- L Cable radial, 2 m
- F Flange connector M23, 12-pin, radial, male, ccw**
- B Flange connector M12, 8-pin, radial, male, ccw
- T Cable axial, 1 m
- U Cable axial, 2 m
- D Flange connector M23, 12-pin, axial, male, ccw
- A Flange connector M12, 8-pin, axial, male, ccw
- P Cable tangential, 1 m
- Q Cable tangential, 2 m

Protection

- 5 IP 65**
- 7 IP 67

Specification hollow shaft

- 08 ø8 mm, clamping ring at A side | U4 ø1/2" (12.7 mm), clamping ring at A side
- U3 ø3/8" (9,52 mm), clamping ring at A side | **14 ø14 mm, clamping ring at A side**
- 10 ø10 mm, clamping ring at A side** | **15 ø15 mm, clamping ring at A side**
- 12 ø12 mm, clamping ring at A side**

Flange

- N Without stator coupling
- T With stator coupling ø63 mm**
- P Torque pin 3 mm, axial/radial

Shaft type

- B Blind hollow shaft

Printed in **bold** = standard items (up to the quantity of 10 will be supplied within 5 working days).

Pulse number

100	300	720	1250	2500
120	360	800	1440	3000
150	400	900	1500	3600
200	500	1000	1800	4000
250	512	1024	2000	4096
256	600	1200	2048	5000

Incremental encoders

With blind or through hollow shaft

100...5000 pulses per revolution

EIL580 - hollow shaft - OptoPulse®

Part number

Through hollow shaft

EIL580- T A

Pulse number - see table

Voltage supply / output stages

- E 5 VDC, TTL/RS422, 6 channel**
- H 8...30 VDC, TTL/RS422, 6 channel
- N 8...30 VDC, HTL/push-pull, 6 channel**
- Q 4.75...30 VDC, HTL/push-pull, 6 channel

Connection

- R Cable radial, 1 m**
- L Cable radial, 2 m
- F Flange connector M23, 12-pin, radial, male, ccw**
- B Flange connector M12, 8-pin, radial, male, ccw
- P Cable tangential, 1 m
- Q Cable tangential, 2 m

Protection

- 5 IP 65**
- 7 IP 67

Specification hollow shaft

- | | | | |
|-----------|--|--|---|
| 08 | ø8 mm, clamping ring at A side | | 15 ø15 mm, clamping ring at A side |
| U3 | ø3/8" (9,52 mm), clamping ring at A side | | V3 ø3/8" (9,52 mm), clamping ring at B side |
| 10 | ø10 mm, clamping ring at A side | | B0 ø10 mm, clamping ring at B side |
| 12 | ø12 mm, clamping ring at A side | | B2 ø12 mm, clamping ring at B side |
| U4 | ø1/2" (12.7 mm), clamping ring at A side | | V4 ø1/2" (12.7 mm), clamping ring at B side |
| 14 | ø14 mm, clamping ring at A side | | B4 ø14 mm, clamping ring at B side |

Flange

- N Without stator coupling
- T With stator coupling ø63 mm**
- P Torque pin 3 mm, axial/radial

Shaft type

- T Through hollow shaft

Printed in **bold** = standard items (up to the quantity of 10 will be supplied within 5 working days).

Pulse number

100	300	720	1250	2500
120	360	800	1440	3000
150	400	900	1500	3600
200	500	1000	1800	4000
250	512	1024	2000	4096
256	600	1200	2048	5000

Incremental encoders

With blind or through hollow shaft

100...5000 pulses per revolution

EIL580 - hollow shaft - OptoPulse®

Accessories

Connectors and cables

10127844	Connection cable 2 m shielded with female connector M12, 8-pin, straight (ESG 34FH0200G)
10129332	Connection cable 5 m shielded with female connector M12, 8-pin, straight (ESG 34FH0500G)
10129333	Connection cable 10 m shielded with female connector M12, 8-pin, straight (ESG 34FH1000G)
11053961	Connection cable 2 m shielded with female connector M12, 8-pin, angled (ESW 33FH0200G)
11053962	Connection cable 5 m shielded with female connector M12, 8-pin, angled (ESW 33FH0500G)
10170054	Connection cable 10 m shielded with female connector M12, 8-pin, angled (ESW 33FH1000G)
10164705	Connector M23, 12-pin
11095302	Connection cable 1 m shielded with female connector M23, 12-pin
11100408	Connection cable 2 m shielded with female connector M23, 12-pin
11100430	Connection cable 5 m shielded with female connector M23, 12-pin
11100431	Connection cable 10 m shielded with female connector M23, 12-pin

Mounting accessories for EIL580 - blind hollow shaft

11066081	Torque arm, 1-arm, bolt circle $\varnothing 82$ mm, mounting M4 (mounting kit 003)
11066083	Torque arm, 1-arm, bolt circle $\varnothing 74...94$ mm, mounting M4/M5 (mounting kit 006)
11073119	Torque arm, 1-arm, bolt circle $\varnothing 65.5...281$ mm, mounting M4, can be cut to length (mounting kit 021)
11067367	Torque arm, 1-arm, bolt circle $\varnothing 74...94$ mm, mounting M6 (mounting kit 028)
11113210	Torque arm, 1-arm, bolt circle $\varnothing 63...94$ mm, mounting M4 (mounting kit 047)
11155325	Mounting plate, 1-arm, pitch circle diameter $\varnothing 95$ mm, mounting M6, isolated, rigid, suitable for Baumer torque arm size M6 (DMS 6) (mounting kit 099)
11129153	Torque arm, 1-arm open, bolt circle $\varnothing 82...108$ mm, mounting M4 (mounting kit 200)
11100198	Stator coupling, 2-armed, bolt circle $\varnothing 63$ mm, mounting M3 (mounting kit 046)
11106627	Fan cover clip 8 mm

Mounting accessories for EIL580 - blind hollow shaft

11094674	Clamping ring 12/31/ 8 M3 8.8 for EIL580 hollow shaft $\varnothing 8...10$ mm for clamping at A or B side
11094675	Clamping ring 17/31/ 8 M3 8.8 for EIL580 hollow shaft $\varnothing 12...15$ mm for clamping at A side
11116921	Insulating sleeve $\varnothing 10$ mm/ $\varnothing 12$ mm/25 mm long
11116923	Insulating sleeve $\varnothing 12$ mm/ $\varnothing 14$ mm/25 mm long

Mounting accessories for EIL580 - through hollow shaft

11066081	Torque arm, 1-arm, bolt circle $\varnothing 82$ mm, mounting M4 (mounting kit 003)
11066083	Torque arm, 1-arm, bolt circle $\varnothing 74...94$ mm, mounting M4/M5 (mounting kit 006)
11073119	Torque arm, 1-arm, bolt circle $\varnothing 65.5...281$ mm, mounting M4, can be cut to length (mounting kit 021)
11067367	Torque arm, 1-arm, bolt circle $\varnothing 74...94$ mm, mounting M6 (mounting kit 028)
11113210	Torque arm, 1-arm, bolt circle $\varnothing 63...94$ mm, mounting M4 (mounting kit 047)
11155325	Mounting plate, 1-arm, pitch circle diameter $\varnothing 95$ mm, mounting M6, isolated, rigid, suitable for Baumer torque arm size M6 (DMS 6) (mounting kit 099)
11129153	Torque arm, 1-arm open, bolt circle $\varnothing 82...108$ mm, mounting M4 (mounting kit 200)
11100198	Stator coupling, 2-armed, bolt circle $\varnothing 63$ mm, mounting M3 (mounting kit 046)
11106627	Fan cover clip 8 mm
11094674	Clamping ring 12/31/ 8 M3 8.8 for EIL580 hollow shaft $\varnothing 8...10$ mm for clamping at A or B side
11094675	Clamping ring 17/31/ 8 M3 8.8 for EIL580 hollow shaft $\varnothing 12...15$ mm for clamping at A side
11123483	Clamping ring 16/31/ 8 M3 8.8 for EIL580 hollow shaft $\varnothing 12...14$ mm for clamping at B side
11116921	Insulating sleeve $\varnothing 10$ mm/ $\varnothing 12$ mm/25 mm long
11116923	Insulating sleeve $\varnothing 12$ mm/ $\varnothing 14$ mm/25 mm long

Incremental encoders

With blind or through hollow shaft
100...5000 pulses per revolution

EIL580 - hollow shaft - *OptoPulse*[®]

Output signals

Clockwise rotating direction when looking at flange.

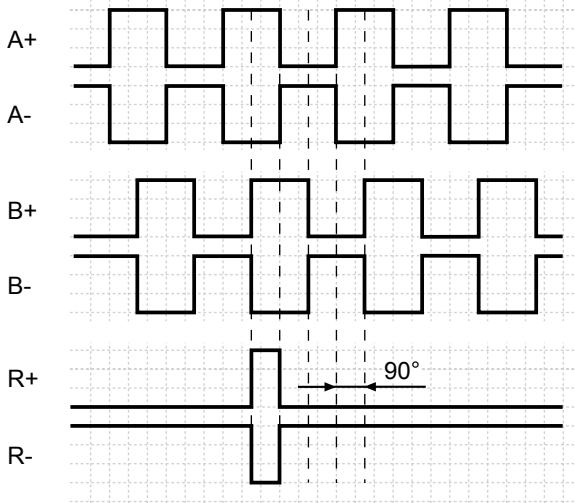

Trigger level

Outputs	TTL/RS422
Output level High	≥ 2.5 V
Output level Low	≤ 0.5 V
Load	≤ 20 mA

Outputs	HTL/Push-pull
Output level High	$\geq U_B - 3$ V
Output level Low	≤ 1.5 V
Load	≤ 20 mA

Terminal assignment

Flange connector M23, 12-pin / cable

Pin	Core color	Assignment
1	pink	B-
2	–	–
3	blue	R+
4	red	R-
5	green	A+
6	yellow	A-
7	–	–
8	grey	B+
9	–	–
10	white	GND
11	–	–
12	brown	UB

Screen: Connected to housing

Cable data: PVC, [4x2x0.14 mm²], bending radius >32.5 mm, outer diameter 6.5 mm

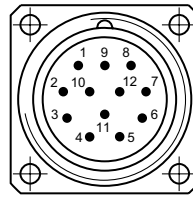

Flange connector M12, 8-pin

Pin	Assignment
1	GND
2	UB
3	A+
4	A-
5	B+
6	B-
7	R+
8	R-

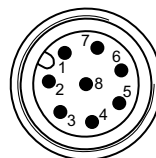

Incremental encoders

With blind or through hollow shaft
100...5000 pulses per revolution

EIL580 - hollow shaft - *OptoPulse®*

Dimensions

Clamping ring at A-side:
Blind hollow shaft, flange connector M12 radial

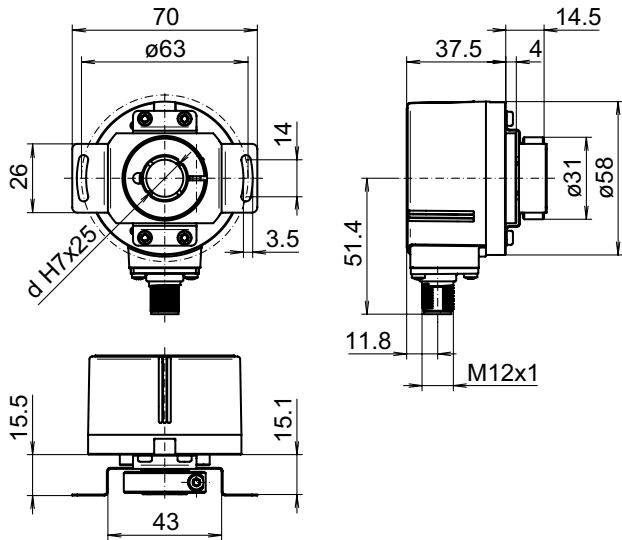

Clamping ring at A-side:
Blind hollow shaft, flange connector M12 axial

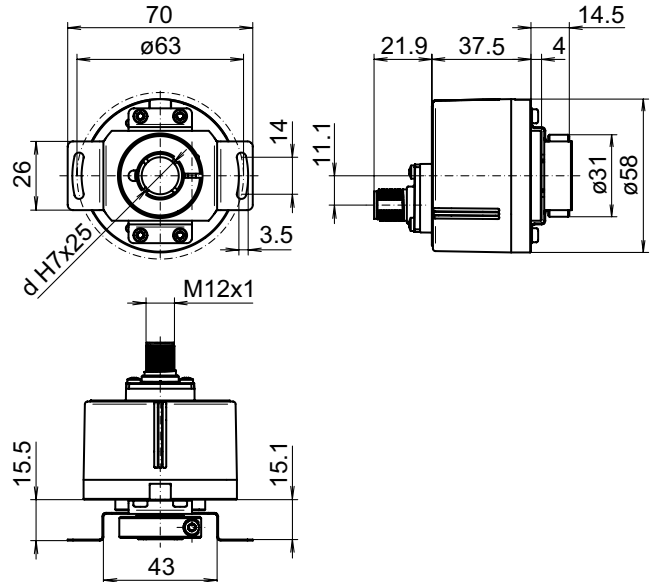

Clamping ring at A-side:
Through hollow shaft, flange connector M12 radial

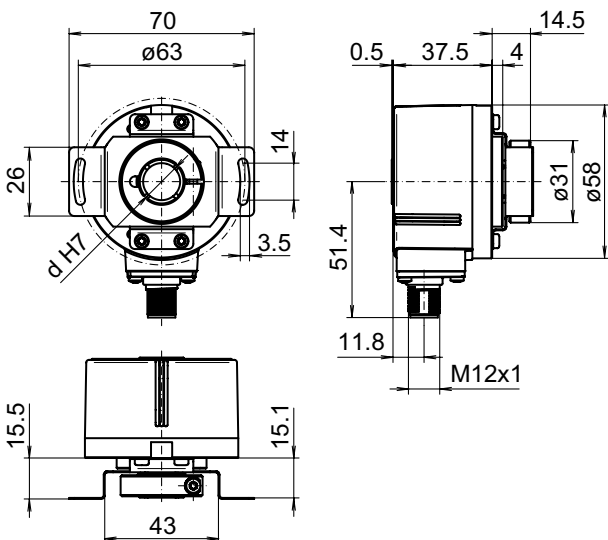

Clamping ring at A-side:
Blind hollow shaft, flange connector M23 radial

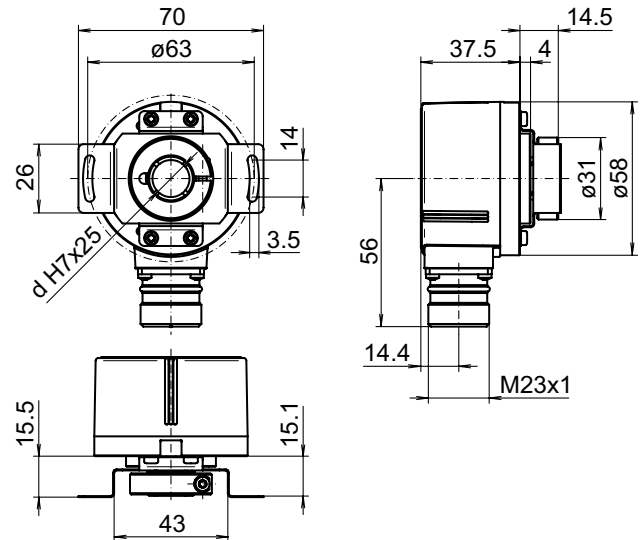

Incremental encoders

With blind or through hollow shaft
100...5000 pulses per revolution

EIL580 - hollow shaft - *OptoPulse*[®]

Dimensions

Clamping ring at A-side:
Blind hollow shaft, flange connector M23 axial

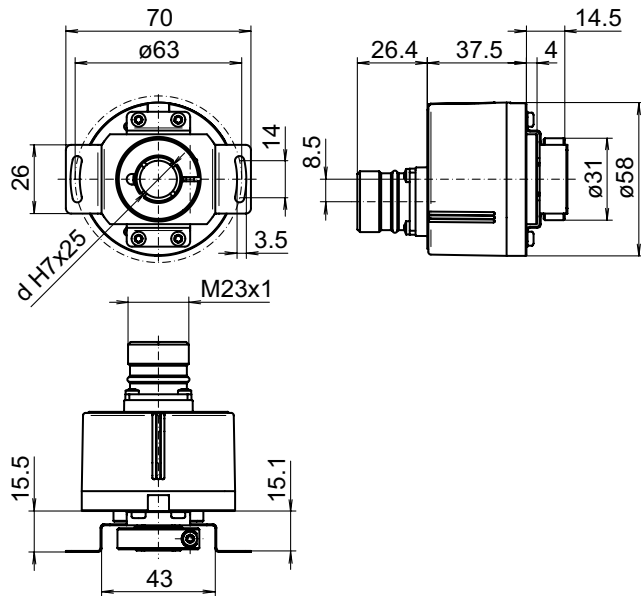

Clamping ring at A-side:
Through hollow shaft, flange connector M23 radial

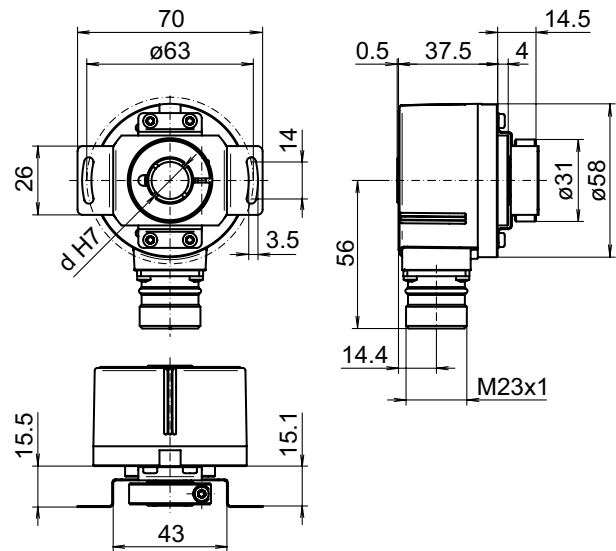

Clamping ring at A-side:
Blind hollow shaft, cable radial

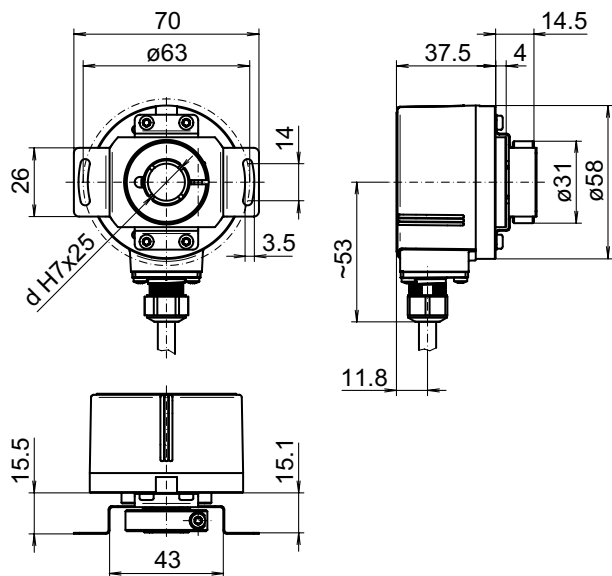

Clamping ring at A-side:
Blind hollow shaft, cable axial

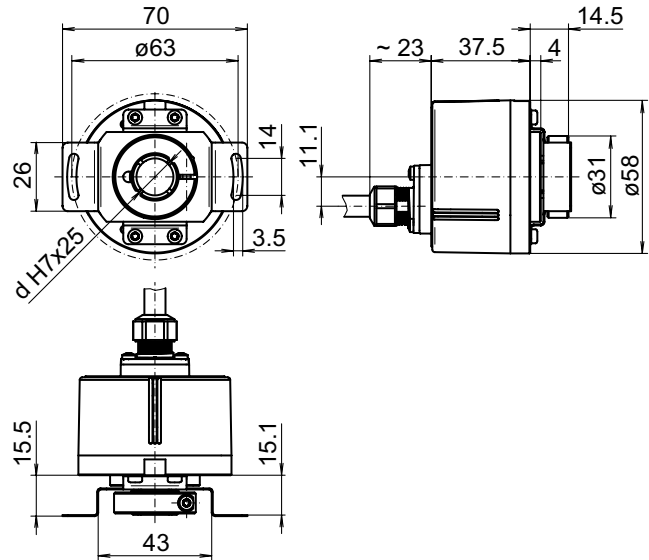

Incremental encoders

With blind or through hollow shaft
100...5000 pulses per revolution

EIL580 - hollow shaft - *OptoPulse*®

Dimensions

**Clamping ring at A-side:
Blind hollow shaft, cable tangential**

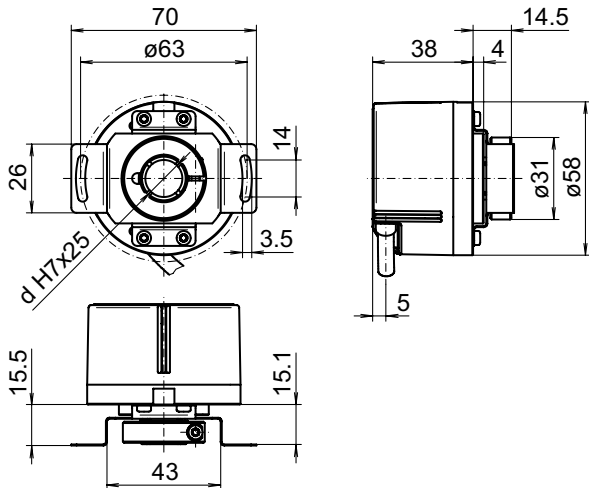

**Clamping ring at A-side:
Through hollow shaft, cable radial**

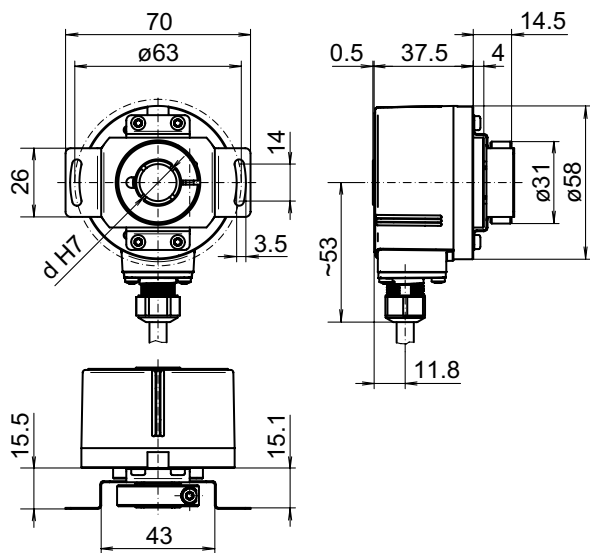

**Clamping ring at A-side:
Through hollow shaft, cable tangential**

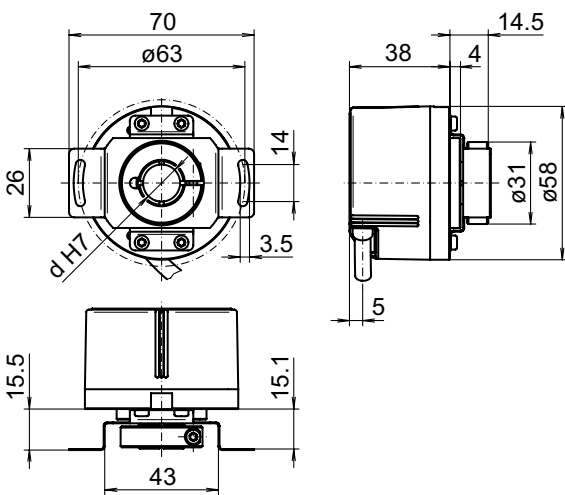

**Clamping ring at B-side:
Through hollow shaft, flange connector M12 radial**

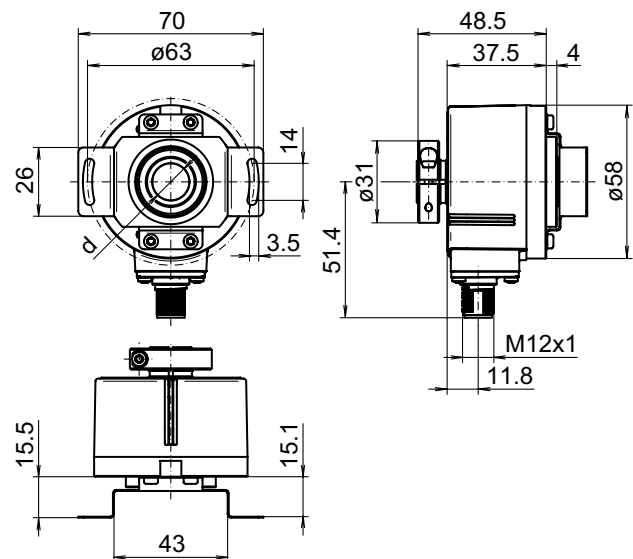

d H7: $\varnothing 10$, $\varnothing 12$, $\varnothing 14$
d G7: $\varnothing 3/8''$ ($\varnothing 9.52$), $\varnothing 1/2''$ ($\varnothing 12.7$)

Incremental encoders

With blind or through hollow shaft
100...5000 pulses per revolution

EIL580 - hollow shaft - *OptoPulse*[®]

Dimensions

Clamping ring at B-side:
Through hollow shaft, flange connector M23 radial

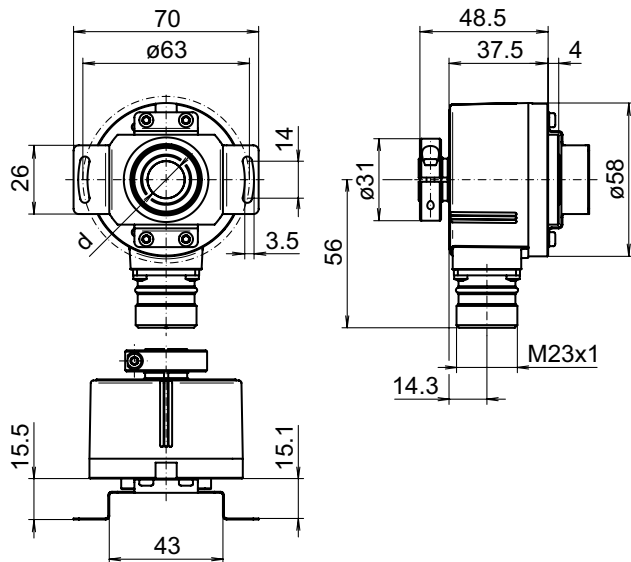

d H7: ø10, ø12, ø14
d G7: ø3/8" (ø9.52), ø1/2" (ø12.7)

Clamping ring at B-side:
Through hollow shaft, cable radial

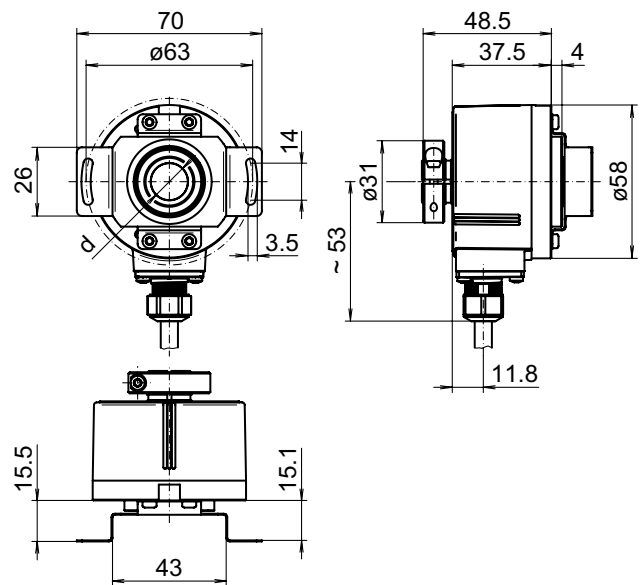

d H7: ø10, ø12, ø14
d G7: ø3/8" (ø9.52), ø1/2" (ø12.7)

Pin torque support, axial, clamping ring at A-side

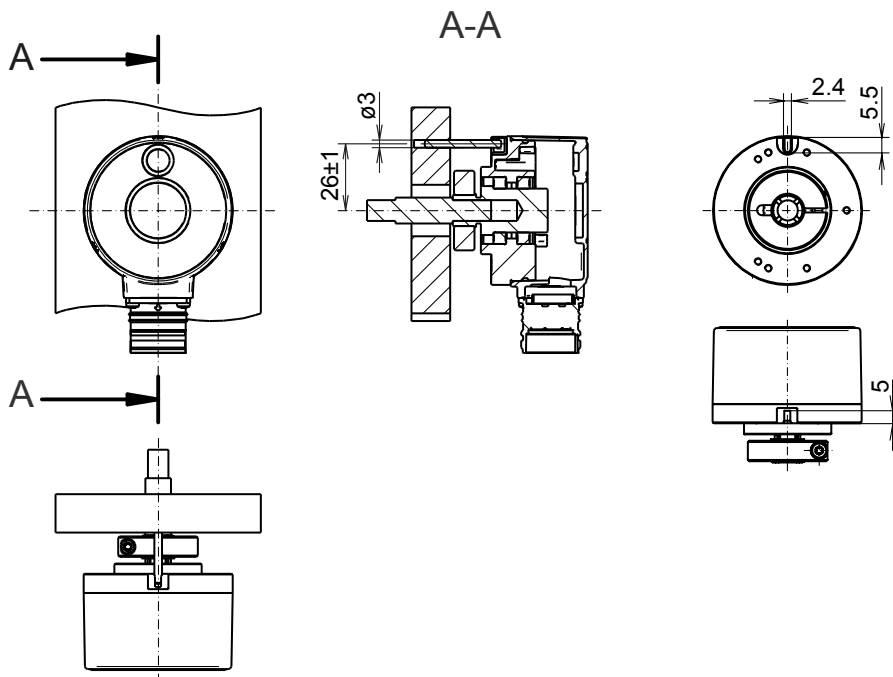

Incremental encoders

With blind or through hollow shaft
100...5000 pulses per revolution

EIL580 - hollow shaft - *OptoPulse*[®]

Dimensions

Clamping ring at A-side: Through hollow shaft

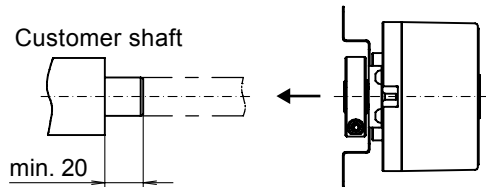

Clamping ring at B-side: Through hollow shaft

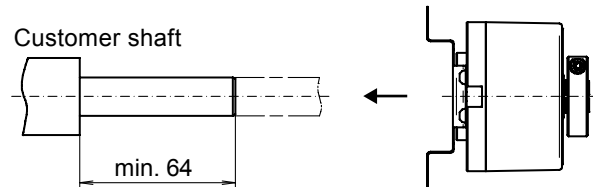

Blind hollow shaft

