

# KPN Series

## Features

- Super high-speed sampling cycle  
(10 times faster compared to existing models)  
: 50ms sampling cycle and  $\pm 0.3\%$  display accuracy
- Improved visibility with wide display and high luminance LED
- Easy check control output MV with Bar graph
- High performance control with heating/cooling control and automatic/manual control modes
- PC parameter setting  
(via USB and RS485 communication)  
: Integrated device management program (DAQMaster) supported
  - ※ Communication converter, sold separately:  
SCM-US48I (USB to RS485 converter),  
SCM-38I (RS232C to RS485 converter),  
SCM-US (USB to Serial converter),
- Selectable SSR drive output or current output
- Heater disconnection alarm (CT input) function
  - ※ CT, sold separately: CSTC-E80LN, CSTC-E200LN
- Multi-SV (up to 4) setting (selectable by digital input terminal)
- Space saving with compact design: downsized by 38% depth-based (panel rear length: 60mm)
- Terminal cover, sold separately: R□A-COVER
- Multi-input/Multi-range



**!** Please read "Caution for your safety" in operation manual before using this unit.

## Manual

- For more information and instructions, refer to the user manual and the user manual for communication. Visit our web site ([www.autonics.com](http://www.autonics.com)) to download the manuals.
- The user manual includes product specifications, functions, and operations.
- The user manual for communication includes information about Modbus RTU protocol, and Modbus mapping table.

## Integrated device management program(DAQMaster)

DAQMaster is the integrated device management program to set parameters and manage monitoring data and user group, parameter mask which are the dedicated function of KPN.

Visit our website ([www.autonics.com](http://www.autonics.com)) to download user manual and integrated device management program.

< Computer specification for using software >

Item	Minimum requirements
System	IBM PC compatible computer with Intel Pentium III or above
Operating system	Microsoft Windows 98/NT/XP/Vista/7
Memory	256MB or more
Hard disk	More than 1GB of free hard disk space
VGA	1024×768 or higher resolution display
Others	RS-232 serial port(9-pin), USB port

< DAQMaster screen >



# High Performance & Accuracy Process Controller

## Ordering information

<b>KPN5</b>	<b>5</b>	<b>0</b>	<b>0</b>	<b>0</b>	<b>0</b>	<b>0</b>
Power supply						
Option input/output						
Option communication output						
Control output*1						
The number of control outputs						
Size						
Item						
KPN5 Temperature / Process Controller						

Power supply	0	100-240VAC 50/60Hz
Option input/output	0	None
	3	Transmission output + Remote SV
Option communication output	0	None
	2	RS485
Control output*1	1 output type	0 Selectable Relay output, Current output, SSR drive output
	2 output type	1 OUT1: Selectable Current output, SSR drive output OUT2: Selectable Current output, SSR drive output
		3 OUT1: Selectable Current output, SSR drive output OUT2: Relay output
		7 OUT1: Relay output OUT2: Selectable Current output, SSR drive output
		9 OUT1: Relay output OUT2: Relay output
The number of control outputs	0	1 output type (Heating or Cooling type)
	1	2 output type (Heating&Cooling type)
Size	2	DIN W96×H48mm
	3	DIN W48×H96mm
	5	DIN W96×H96mm
Item	KPN5	Temperature / Process Controller

※ 1: The 1 output type is heating or cooling output type and the 2 output type is heating & cooling output type.  
 The 1 output type is able to use only one output among relay output, current output, SSR drive output.  
 OUT1 of the 2 output type is fixed as heating output and OUT2 of the 2 output type is fixed as cooling output.  
 If you select the SSR drive output or current output model, you can select the appropriate control output.

- A. Recorders
- B. Indicators
- C. Converters
- D. Controllers**
- E. Thyristor units
- F. Pressure transmitters
- G. Temperature transmitters
- H. Accessories

## Connections

KPN

© KPN5□00

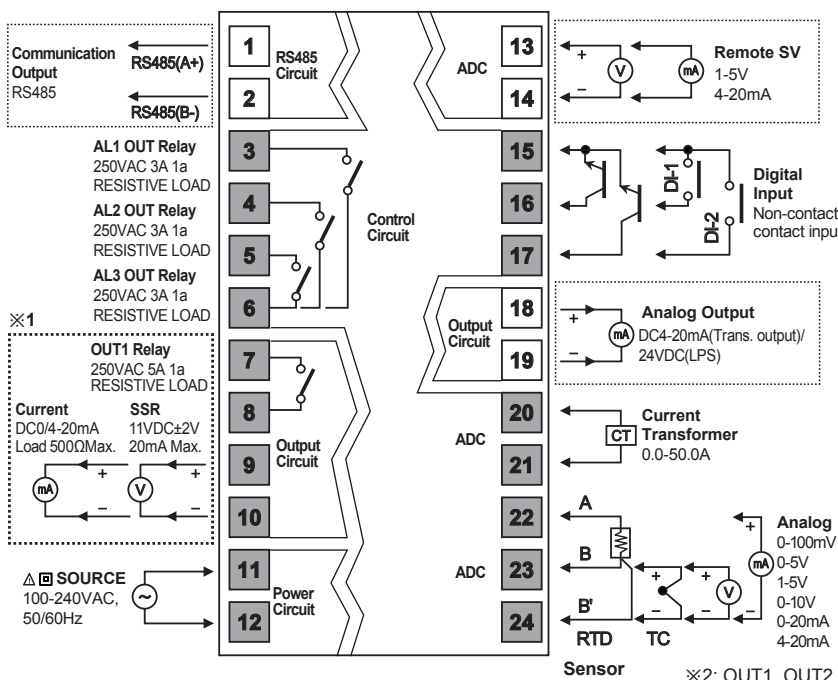

© KPN5□1□

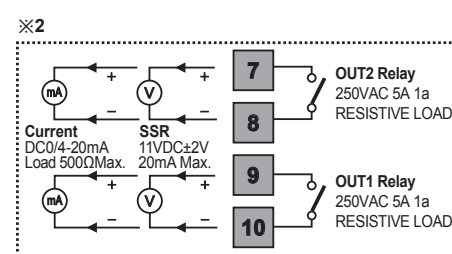

※1: Set relay output [RLY], current [CUR], or SSR drive output [SSR] at OUT1 control output [OUT1] in parameter 3 group.

※ Standard model has shaded terminals only. □ is option specification.

※2: OUT1, OUT2

Model	OUT1 control output	OUT2 control output
KPN5□11	Selectable Current output, SSR drive output	Selectable Current output, SSR drive output
KPN5□13	Selectable Current output, SSR drive output	Relay output
KPN5□17	Relay output	Selectable Current output, SSR drive output
KPN5□19	Relay output	Relay output

# KPN Series

## Dimensions

### ◎ KPN52□□

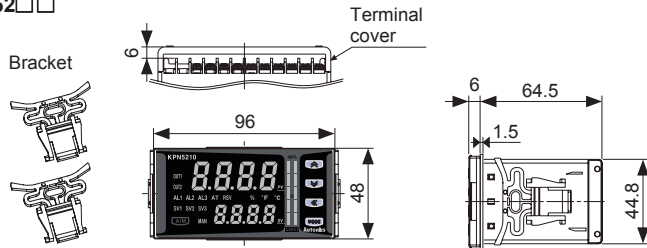

### ● Panel cut-out

(unit:mm)

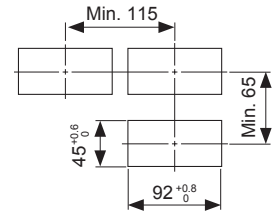

### ◎ KPN53□□

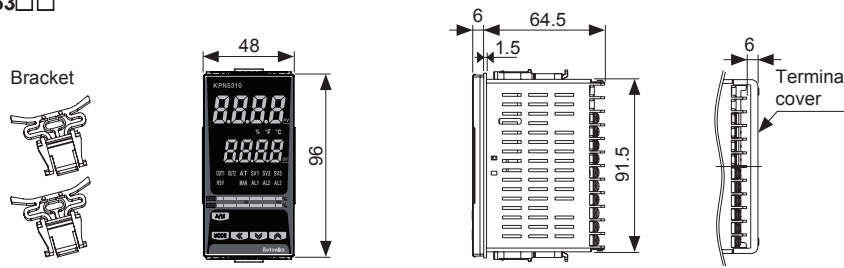

### ● Panel cut-out

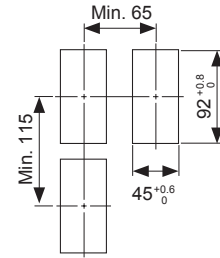

### ◎ KPN55□□

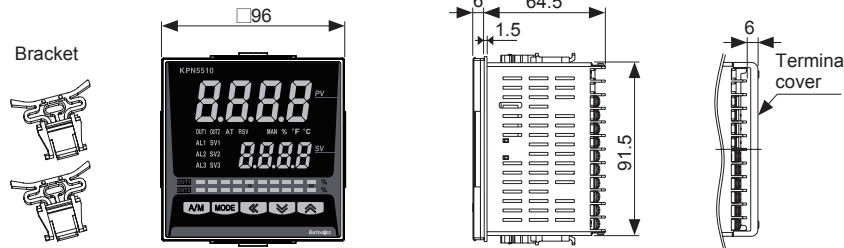

### ● Panel cut-out

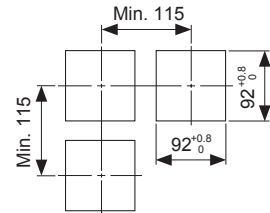

### ◎ Terminal cover (sold separately)

- RHA-COVER (48×96 mm size)

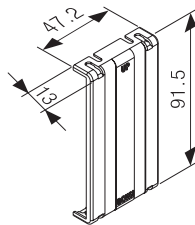

- RLA-COVER (96×96 mm size)

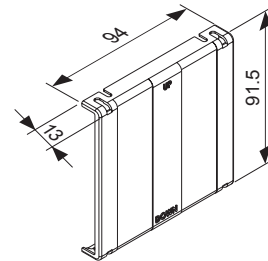

### ◎ Current transformer (CT, sold separately)

- CSTC-E80LN

Max. load current: 80A (50/60Hz)  
 ※Max. load current for KPN Series is 50A.  
 Current ratio: 1/1000  
 Wire round resistance:  $31\Omega \pm 10\%$

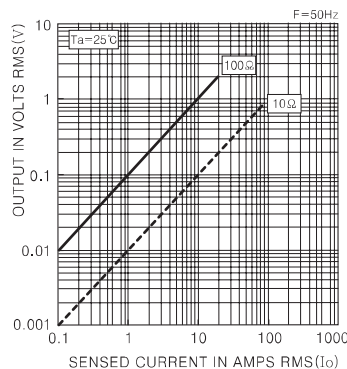

- CSTC-E200LN

Max. load current: 200A (50/60Hz)  
 ※Max. load current for KPN Series is 50A.  
 Current ratio: 1/1000  
 Wire round resistance:  $20\Omega \pm 10\%$

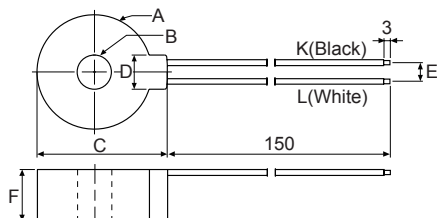
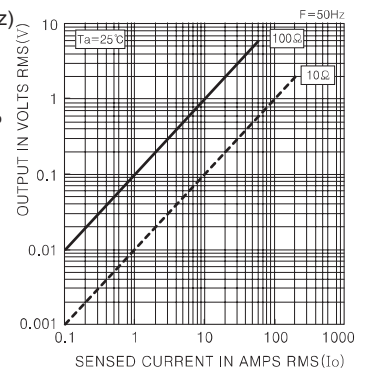

Model	A	B	C	D	E	F
CSTC-E80N	Ø23.3	Ø7	26.5	7	3.8	10.5
CSTC-E200N	Ø37.1	Ø13	40.8	10	4.5	13.5

※ When using a CT, do not apply primary current when opening CT output.  
 Or high voltage occurs at CT output.

# High Performance & Accuracy Process Controller

## Sold Separately

### ◎ Communication converter

● **SCM-US48I**  
(USB to RS485 converter)

CE



● **SCM-38I**  
(RS232C to RS485 converter)

CE



● **SCM-US**  
(USB to Serial converter)

CE



## Input type and range

Input type		Dot	Parameter	Input range (°C)	Input range (°F)
Thermocouple	K(CA)	1	ECk1	-200 to 1350	-328 to 2463
		0.1	ECk2	-199.9 to 999.9	-199.9 to 999.9
	J(IC)	1	ECJ1	-200 to 800	-328 to 1472
		0.1	ECJ2	-199.9 to 800.0	-199.9 to 999.9
	E(CR)	1	ECE1	-200 to 800	-328 to 1472
		0.1	ECE2	-199.9 to 800.0	-199.9 to 999.9
	T(CC)	1	ECT1	-200 to 400	-328 to 752
		0.1	ECT2	-199.9 to 400.0	-199.9 to 752.0
	B(PR)	1	EC-b	0 to 1800	32 to 3272
	R(PR)	1	EC-r	0 to 1750	32 to 3182
	S(PR)	1	EC-S	0 to 1750	32 to 3182
	N(NN)	1	EC-n	-200 to 1300	-328 to 2372
	C(TT)*1	1	EC-C	0 to 2300	32 to 4172
	G(TT)*2	1	EC-G	0 to 2300	32 to 4172
L(IC)	1	EC-L1	-200 to 900	-328 to 1652	
	0.1	EC-L2	-199.9 to 900.0	-199.9 to 999.9	
U(CC)	1	EC-U1	-200 to 400	-328 to 752	
	0.1	EC-U2	-199.9 to 400.0	-199.9 to 752.0	
RTD	Platinel II	1	EC-P	0 to 1390	32 to 2534
	Cu50Ω	0.1	CU50	-199.9 to 200.0	-199.9 to 392.0
	Cu100Ω	0.1	CU10	-199.9 to 200.0	-199.9 to 392.0
	JPt100Ω	1	JPt.1	-200 to 650	-328 to 1202
		0.1	JPt.2	-199.9 to 650.0	-199.9 to 999.9
	DPt50Ω	0.1	dPt.5	-199.9 to 650.0	-199.9 to 999.9
	DPt100Ω	1	dPt.1	-200 to 650	-328 to 1202
		0.1	dPt.2	-199.9 to 650.0	-199.9 to 999.9
Nickel120Ω	1	ni.12	-80 to 200	-112 to 392	
Analog	0-10V		A-u1	-1999 to 9999 (display range depends on the decimal point position )	
	0-5V		A-u2		
	1-5V		A-u3		
	0-100mV		A-nu1		
	0-20mA		A-nA1		
	4-20mA		A-nA2		

※ 1: C(TT) : Same as existing W5(TT) type sensor.

※ 2: G(TT) : Same as existing W(TT) type sensor.

A. Recorders

B. Indicators

C. Converters

D. Controllers

E. Thyristor units

F. Pressure transmitters

G. Temperature transmitters

H. Accessories

KPN

# KPN Series

## Specifications

Series	KPN52□□	KPN53□□	KPN55□□
Power supply	100-240VAC 50/60Hz		
Allowable voltage range	90 to 110% of rated voltage		
Power consumption	Max. 15VA		
Display method	7Segment(red, green), control Bar graph: red, green		
Character size	PV(W×H)	8.5×17.0mm	7.0×14.6mm
	SV(W×H)	6.0×12.0mm	6.0×12.0mm
Input type	RTD	JPt100Ω, DPt100Ω, DPt50Ω, Cu100Ω, Cu50Ω, Nickel120Ω(6 types)	
	TC	K, J, E, T, L, N, U, R, S, B, C, G, PLII(13 types)	
	Analog	· Voltage: 0-100 mV, 0-5 V, 1-5 V, 0-10 V(4 types) · Current: 0-20mA, 4-20mA(2 types)	
Display accuracy	RTD	· At room temperature (23±5°C): (PV ±0.3% or ±1°C, select the higher one) ±1digit ※1	
	TC	· Out of room temperature range: (PV ±0.5% or ±2°C, select the higher one) ±1digit	
	Analog	At room temperature (23±5°C): ±0.3% F.S.±1digit, Out of room temperature range: ±0.5% F.S.±1digit	
	CT input	±5% F.S.±1digit	
Control output	Relay	OUT1, OUT2 : 250VAC 5A 1a	
	SSR	Max. 11VDC±2V 20mA	
	Current	0-20mA or 4-20mA selectable (resistive load max. 500Ω)	
Alarm output	Relay	AL1, AL2, AL3 Relay contact capacity 250VAC 3A 1a	
Option output	Transmission	4-20mA (Load max. 600Ω, output accuracy: ±0.3% F.S.±1digit)	
	Communication	RS485 communication output (Modbus RTU method)	
Option input	CT	0.0-50.0A(primary heater current value measuring range) ※CT ratio is 1/1000	
	Remote SV	1-5VDC or 4-20mA(current input: using external resistance 250Ω)	
	Digital input	· Contact input: Max. 2kΩ in ON, Min. 90kΩ in ON · Non-contact input: Residual voltage max. 1.0V in ON, leakage current max. 0.1mA in OFF	
Control type	Heating, Cooling	ON/OFF control, P, PI, PD, PID control	
	Heating&Cooling		
Hysteresis	· Thermocouple/RTD: 1 to 100°C/°F(0.1 to 100.0°C/°F) variable · Analog: 1 to 100 digit		
Proportional band (P)	0.1 to 999.9°C(0.1 to 999.9%)		
Integral time(I)	0 to 9999 sec.		
Derivative time (D)	0 to 9999 sec.		
Control period(T)	Relay output, SSR drive output: 0.1 to 120.0 sec. Current output + SSR drive output: 1.0 to 120.0 sec.		
Manual reset value	0.0 to 100.0%		
Sampling period	50ms		
Dielectric strength	2000VAC 50/60Hz for 1 min. (between input terminal and power source terminal)		
Vibration	0.75mm amplitude at frequency of 5 to 55Hz (for 1 min.) in each X, Y, Z direction for 2 hours		
Relay life cycle	Mechanical	Over 10,000,000 operations	
	Electrical	Over 100,000 operations (250VAC 3A resistance load)	
Insulation resistance	Over 100MΩ (at 500VDC megger)		
Noise resistance	Square shaped noise by noise simulator (pulse width 1μs) ±2kV R-phase, S-phase		
Memory retention	Approx. 10 years (when using non-volatile semiconductor memory type)		
Environment	Ambient temperature	-10 to 50°C, storage: -20 to 60°C	
	Ambient humidity	35 to 85%RH, storage: 35 to 85%RH	
Protection	IP65(front part)		
Insulation type	Double insulation or reinforced insulation (mark: □), dielectric strength between the measuring input part and the power part: 1kV)		
Weight※2	Approx. 230g (Approx. 160g)		Approx. 316g (Approx. 220g)

※1. ◎ At room temperature (23°C±5°C)

- TC K, J, T, N, E type, below -100°C / L, U, PLII, RTD Cu50, DPt50: (PV ±0.3% or ±2°C, select the higher one) ±1digit
- TC C, G and R, S type, below 200°C: (PV ±0.3% or ±3°C, select the higher one) ±1digit
- TC B type, below 400°C, there is no accuracy standards.
- ◎ Out of room temperature range
- RTD Cu50, DPt50: (PV 0.5% or ±3°C, select the higher one) ±1digit
- RTD R, S, B, C, G: (PV ±0.5% or ±10°C, select the higher one) ±1digit
- Other sensors: Below -100°C, within ±5°C

※2. The weight includes packaging. The weight in parentheses is for unit only.

※ Environment resistance is rated at no freezing or condensation.

# High Performance & Accuracy Process Controller

## Part descriptions

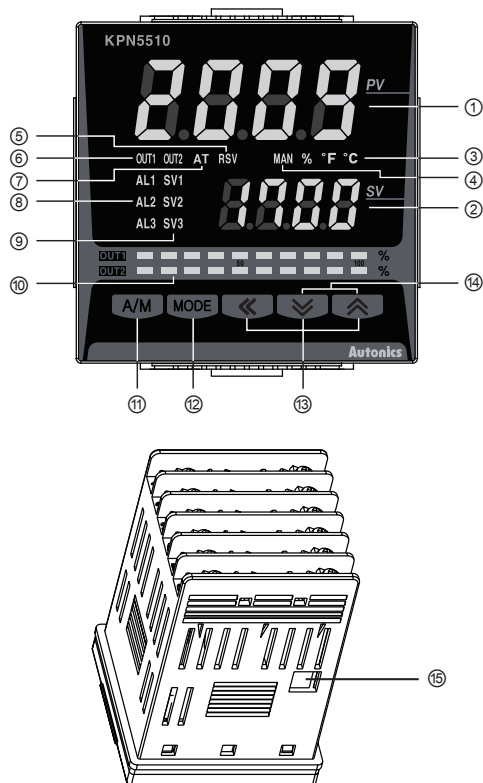

- ① Measured value (PV) display part
  - RUN mode: Displays currently measured value (PV).
  - Set mode: Displays the parameters.
- ② Set value (SV) display part
  - RUN mode: Displays the set value (SV).
  - Set mode: Displays the set value of the parameter.
- ③ Unit (°C/°F/%) indicator: Displays the unit set at display unit [ d i s p l a y ] in parameter 3 group.
- ④ Manual control indicator : Turns ON during manual controlling.
- ⑤ Remote SV control indicator : Turns ON during remote SV controlling.
- ⑥ Control output (OUT1, OUT2) indicator: Turns ON when the control output is ON.
  - ※ Using current output, in case that for manual control MV is 0.0%, the control output indicator turns OFF but the other cases it turns ON always. In case that for auto control MV is over 3.0%, it turns ON and the MV is below 2.0%, it turns OFF.
- ⑦ Auto tuning indicator: Flashes by 1 sec. when executing auto tuning.
- ⑧ Alarm output (AL1, AL2, AL3) indicator: Turns ON when the alarm output is ON.
- ⑨ Multi SV indicator: The SV 1 to 3 indicator turns ON when using multi SV function.
- ⑩ Bar graph for control output: Displays control output MV as bar graph. KPN5□00 as 1 output type has one bar graph (OUT1), and the KPN5□1□ as 2 output type has two bar graphs (OUT1, OUT2).
- ⑪ **A/M** key: Used when switching auto control to manual control.
- ⑫ **MODE** key: Used when entering parameter setting group, returning to RUN mode, moving parameter, saving the set value.

- ⑬ **←**, **→**, **↑** key: Used when entering the set value changing mode and moving or changing up/down digit.
  - ⑭ Digital input key : When pressing the **→** + **↑** keys for 3 sec. at the same time, it operates the function (RUN/STOP, alarm clear, auto-tuning) set at digital input key [ d i - t ] in parameter 5 group.
  - ⑮ PC loader port: It is the PC loader port for serial communication to set and monitor parameters by PC. Use this port for connection SCM-US (USB to serial converter).
- ※ Display part is different by options.

A. Recorders
B. Indicators
C. Converters
<b>D. Controllers</b>
E. Thyristor units
F. Pressure transmitters
G. Temperature transmitters
H. Accessories

KPN

## SV settings

You can set the temperature to control with the **←**, **→**, **↑** keys.  
 Set range is within SV low-limit value [ L - 5 u ] to SV high-limit value [ H - 5 u ].  
 ※ Ex) In case of changing set temperature from 210 °C to 250 °C

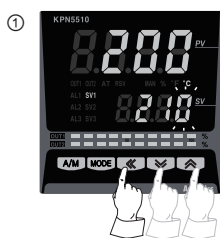

Press any key among the **←**, **→**, **↑** in RUN mode to enter into SV setting mode. Last digit (10<sup>0</sup> digit) on SV display part flashes.

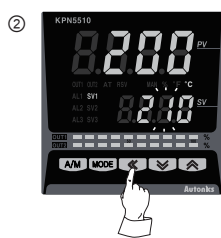

Press the **←** key to move digit. (10<sup>0</sup> → 10<sup>1</sup> → 10<sup>2</sup> → 10<sup>3</sup> → 10<sup>0</sup>)



Press the **→** or **↑** key to raise or lower the setting value. (1 → 5)

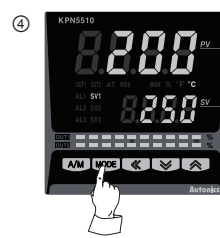

Press the **MODE** key to save the setting value. If there is no additional key operations in 3 sec., the changed SV is automatically saved.

## Parameter groups

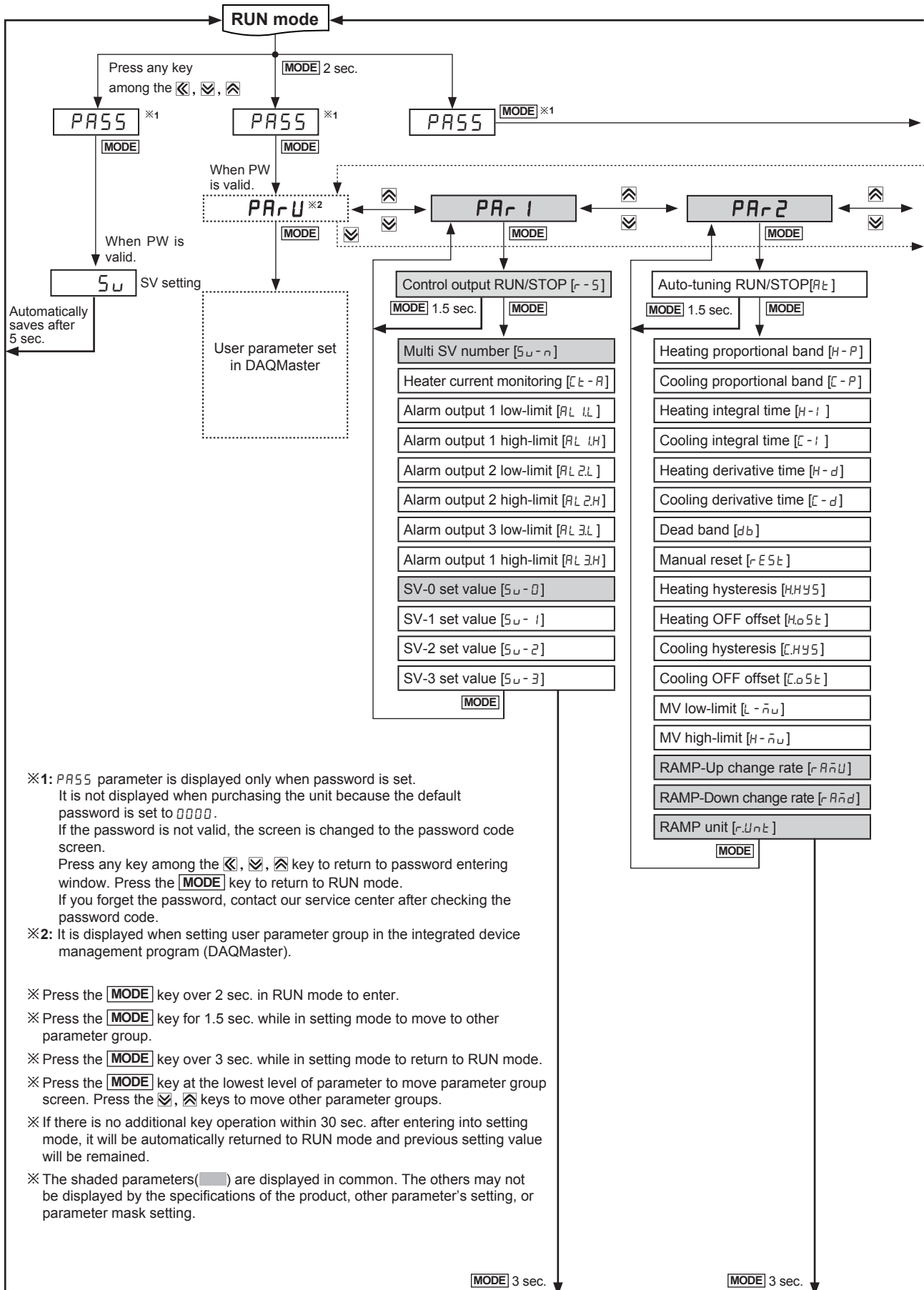



# High Performance & Accuracy Process Controller

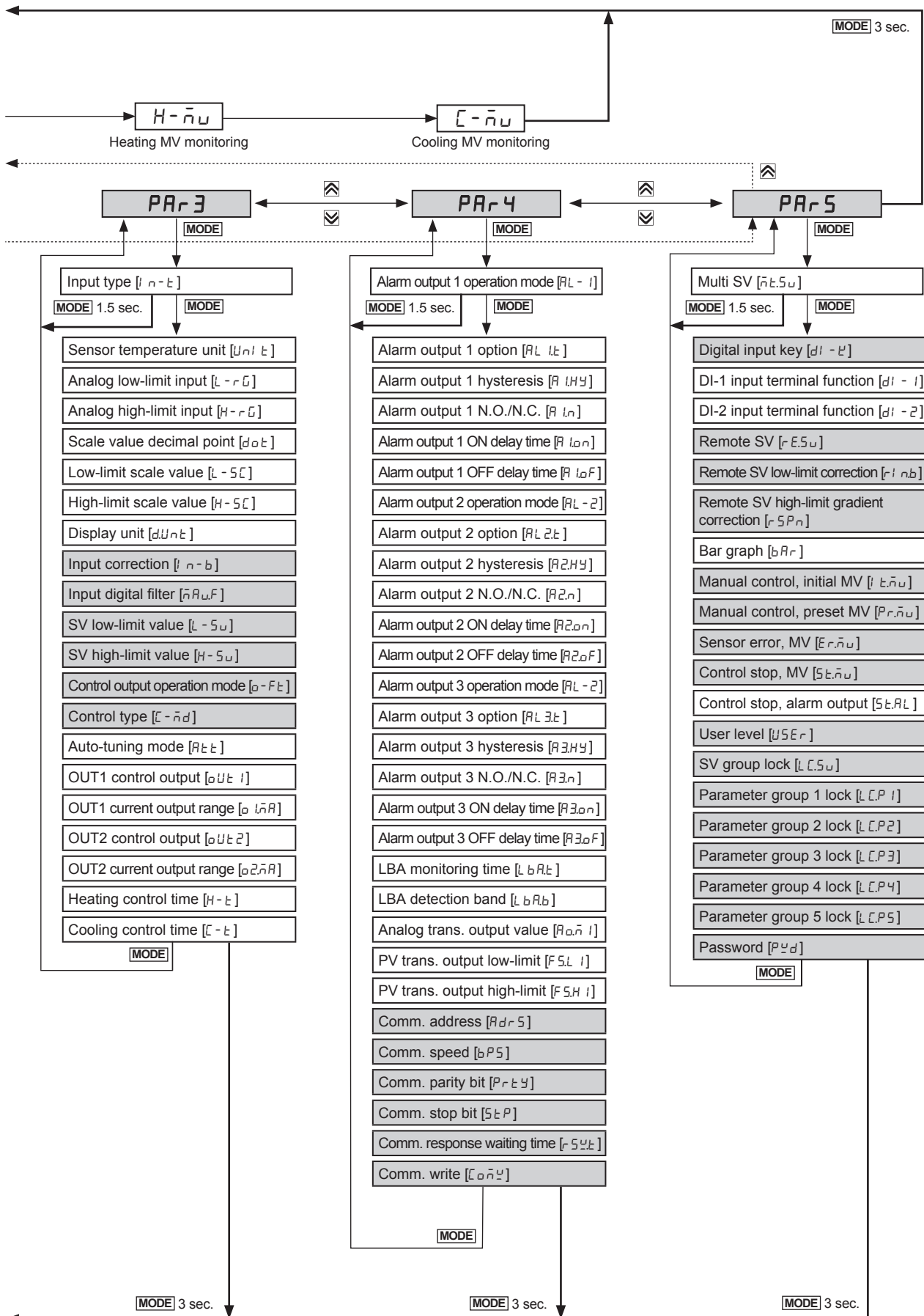

- A. Recorders
- B. Indicators
- C. Converters
- D. Controllers**
- E. Thyristor units
- F. Pressure transmitters
- G. Temperature transmitters
- H. Accessories

KPN



# KPN Series

## Parameter 1 group

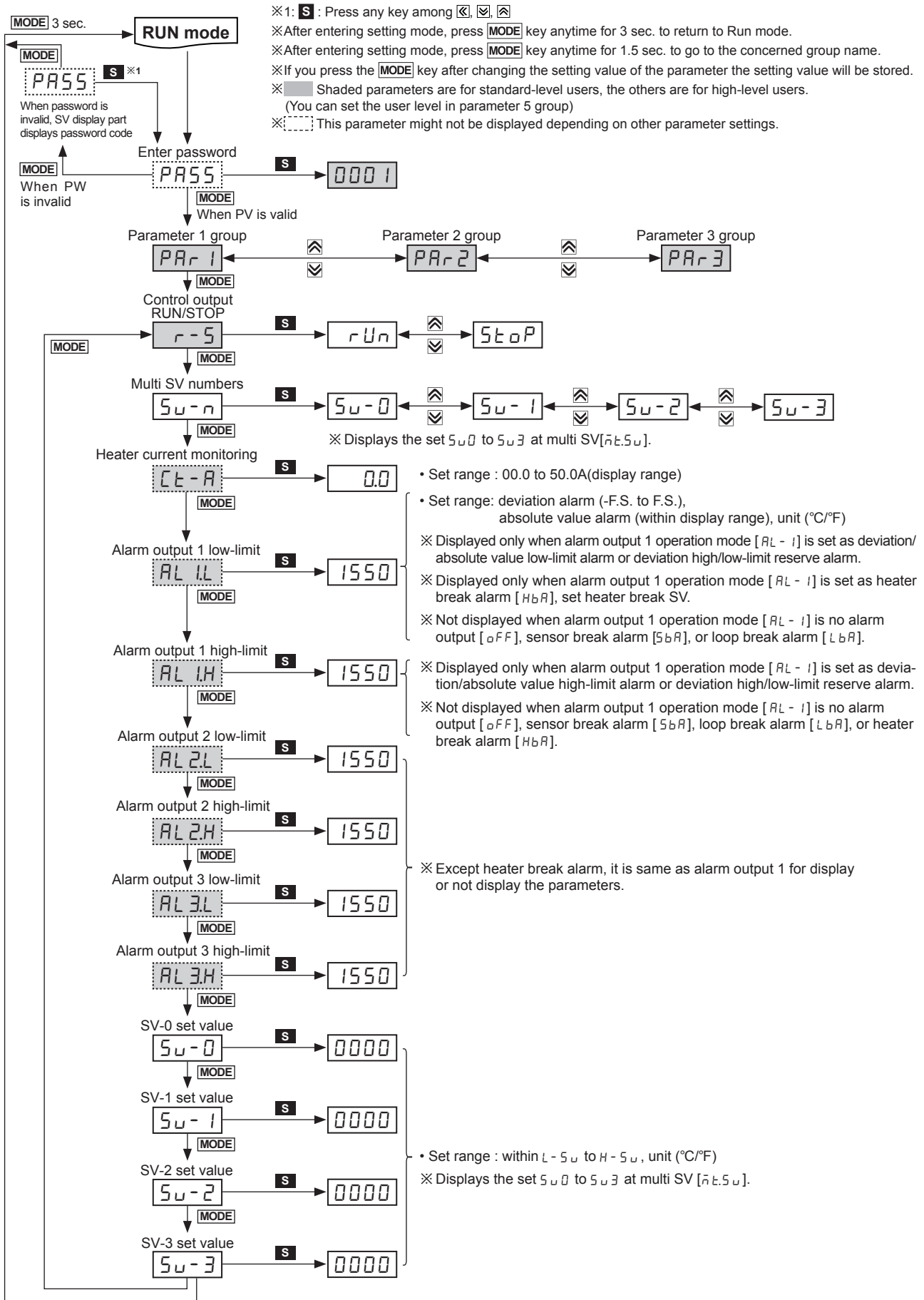

# High Performance & Accuracy Process Controller

## Parameter 2 group

- ※1: **S** : Press any key among  $\leftarrow$ ,  $\rightarrow$ ,  $\uparrow$ ,  $\downarrow$
- ※After entering setting mode, press **MODE** key anytime for 3 sec. to return to Run mode.
- ※After entering setting mode, press **MODE** key anytime for 1.5 sec. to go to the concerned group name.
- ※If you press the **MODE** key after changing the setting value of the parameter the setting value will be stored.
- ※   Shaded parameters are for standard-level users, the others are for high-level users.  
(You can set the user level in parameter 5 group)
- ※  This parameter might not be displayed depending on other parameter settings.

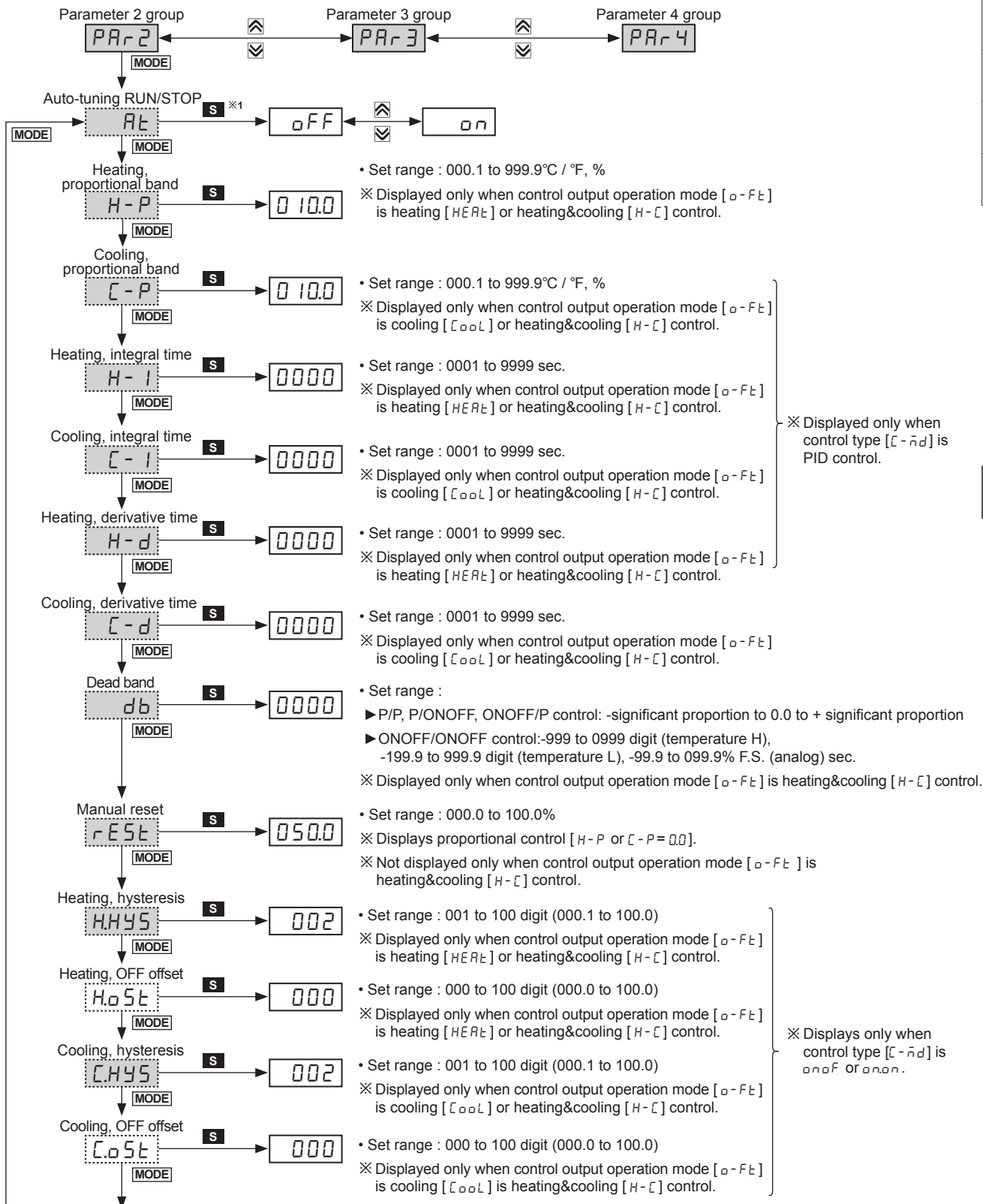

A. Recorders
B. Indicators
C. Converters
D. Controllers
E. Thyristor units
F. Pressure transmitters
G. Temperature transmitters
H. Accessories

KPN

# KPN Series

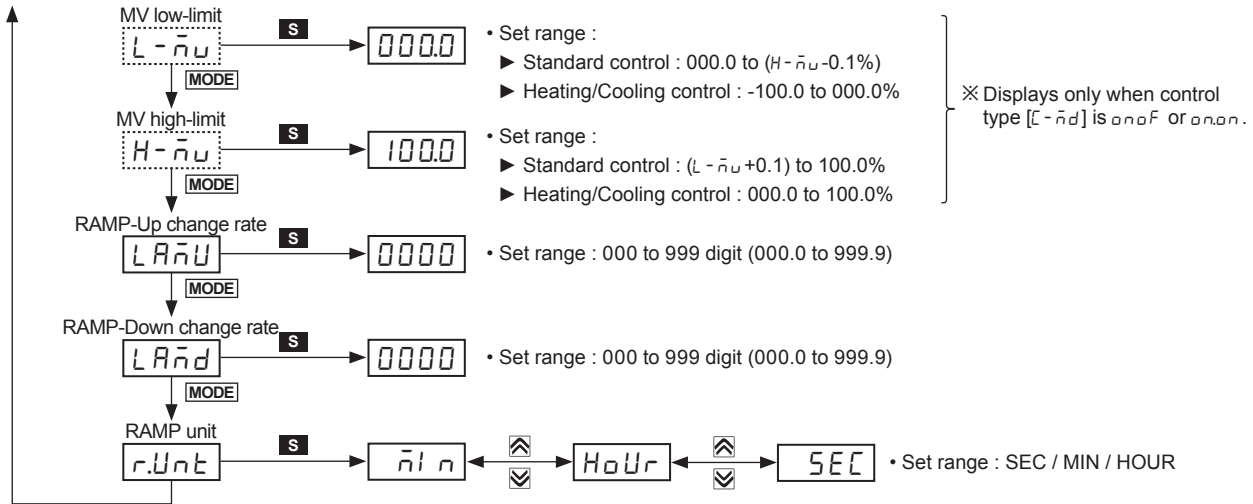

## Parameter 3 group

- ※1: **S** : Press any key among  $\leftarrow$ ,  $\rightarrow$ ,  $\uparrow$ ,  $\downarrow$
- ※ After entering setting mode, press **MODE** key anytime for 3 sec. to return to Run mode.
- ※ After entering setting mode, press **MODE** key anytime for 1.5 sec. to go to the concerned group name.
- ※ If you press the **MODE** key after changing the setting value of the parameter the setting value will be stored.
- ※   Shaded parameters are for standard-level users, the others are for high-level users.  
(You can set the user level in parameter 5 group)
- ※   This parameter might not be displayed depending on other parameter settings.

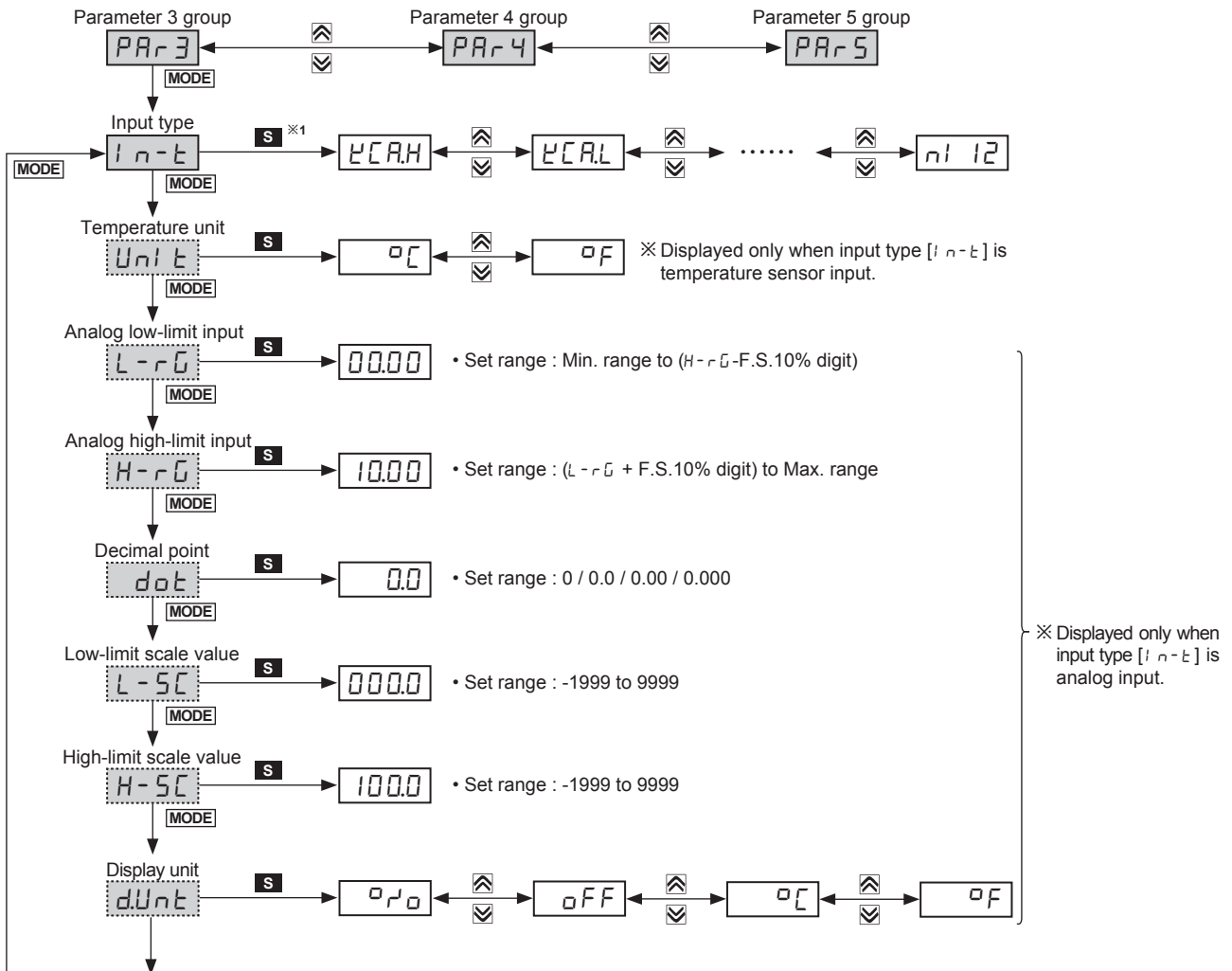

# High Performance & Accuracy Process Controller



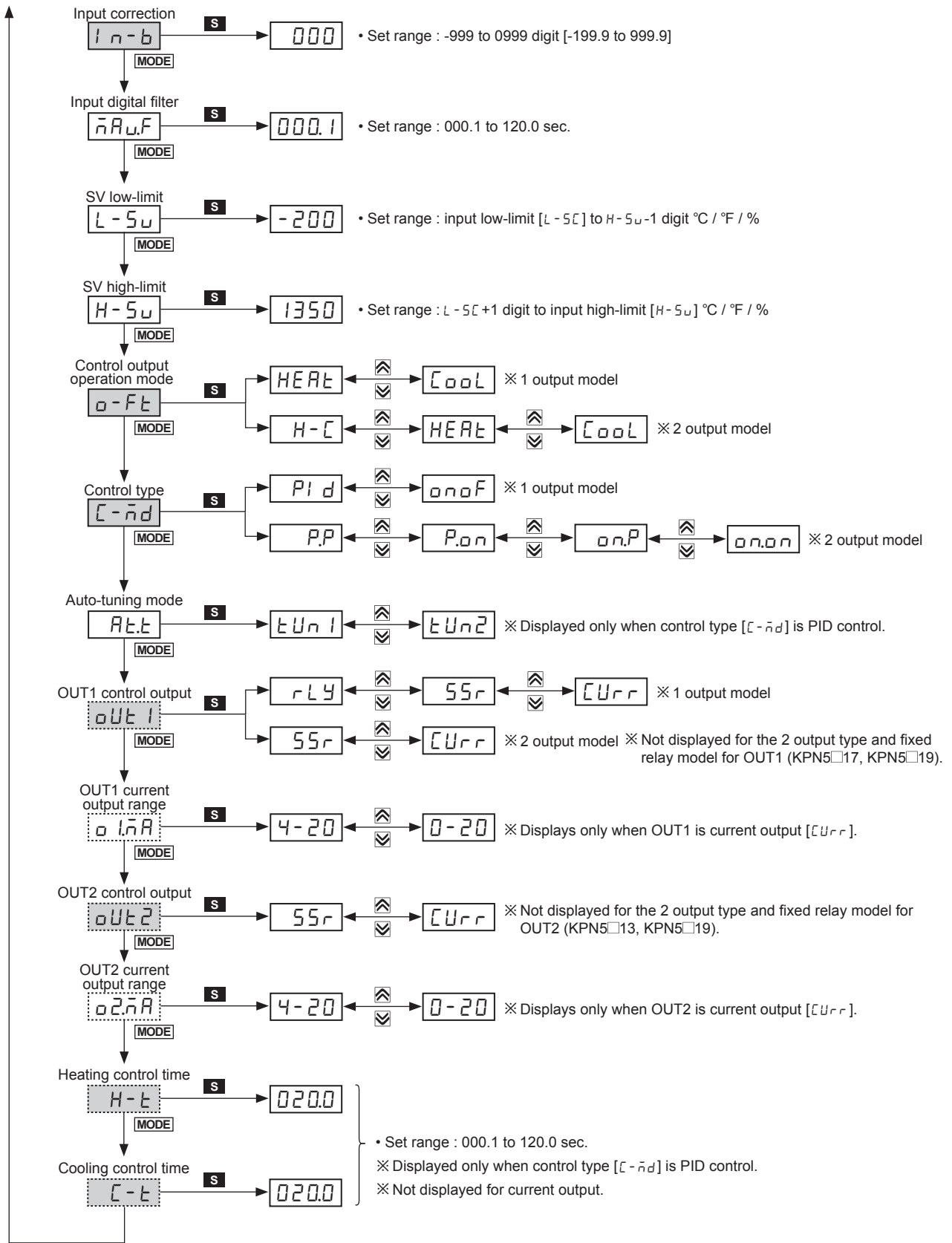

A. Recorders
B. Indicators
C. Converters
<b>D. Controllers</b>
E. Thyristor units
F. Pressure transmitters
G. Temperature transmitters
H. Accessories



KPN

# KPN Series

## Parameter 4 group

- ※1: **S** : Press any key among , , 
- ※After entering setting mode, press **MODE** key anytime for 3 sec. to return to Run mode.
- ※After entering setting mode, press **MODE** key anytime for 1.5 sec. to go to the concerned group name.
- ※If you press the **MODE** key after changing the setting value of the parameter the setting value will be stored.
- ※  Shaded parameters are for standard-level users, the others are for high-level users.  
(You can set the user level in parameter 5 group)
- ※  This parameter might not be displayed depending on other parameter settings.

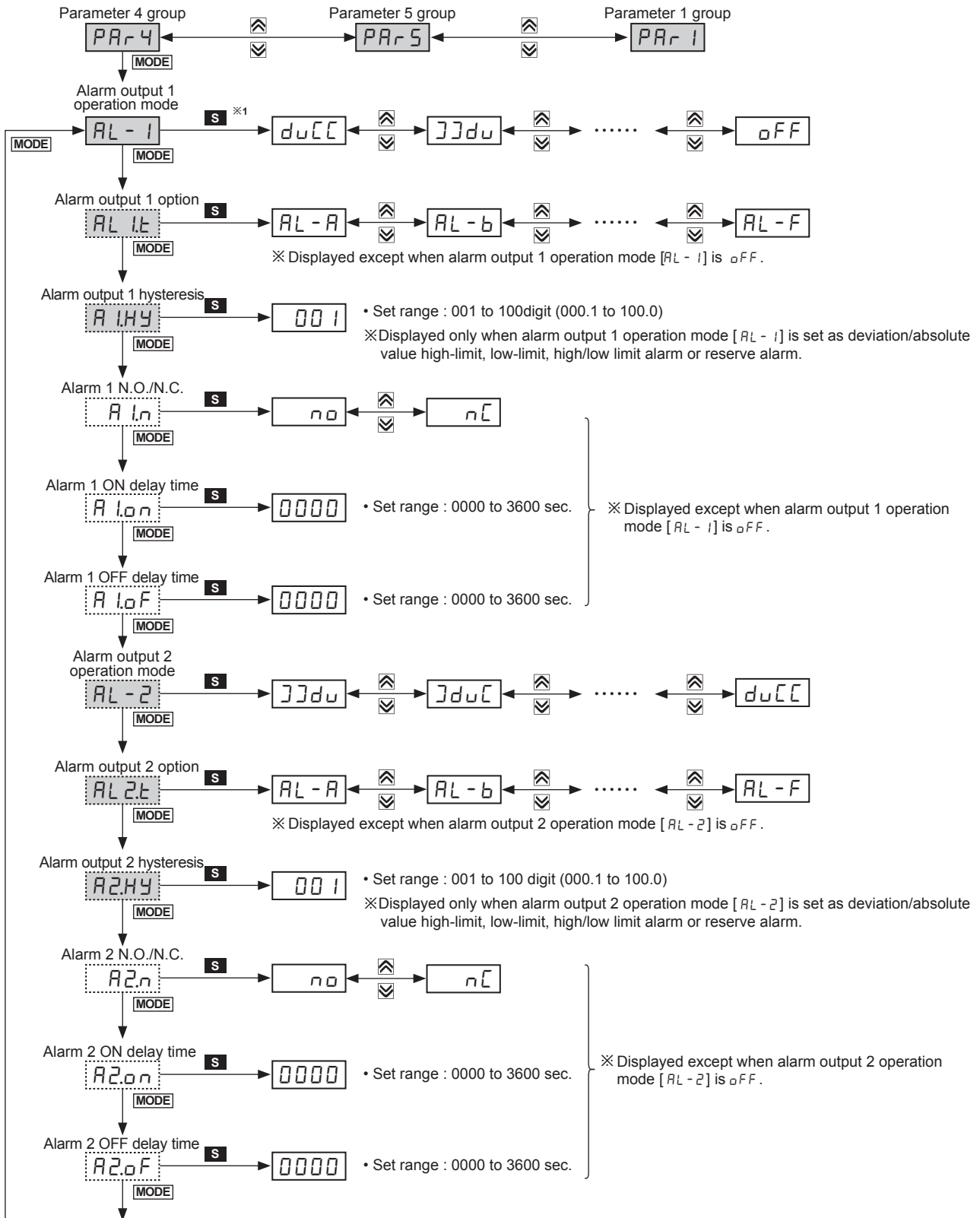

# High Performance & Accuracy Process Controller

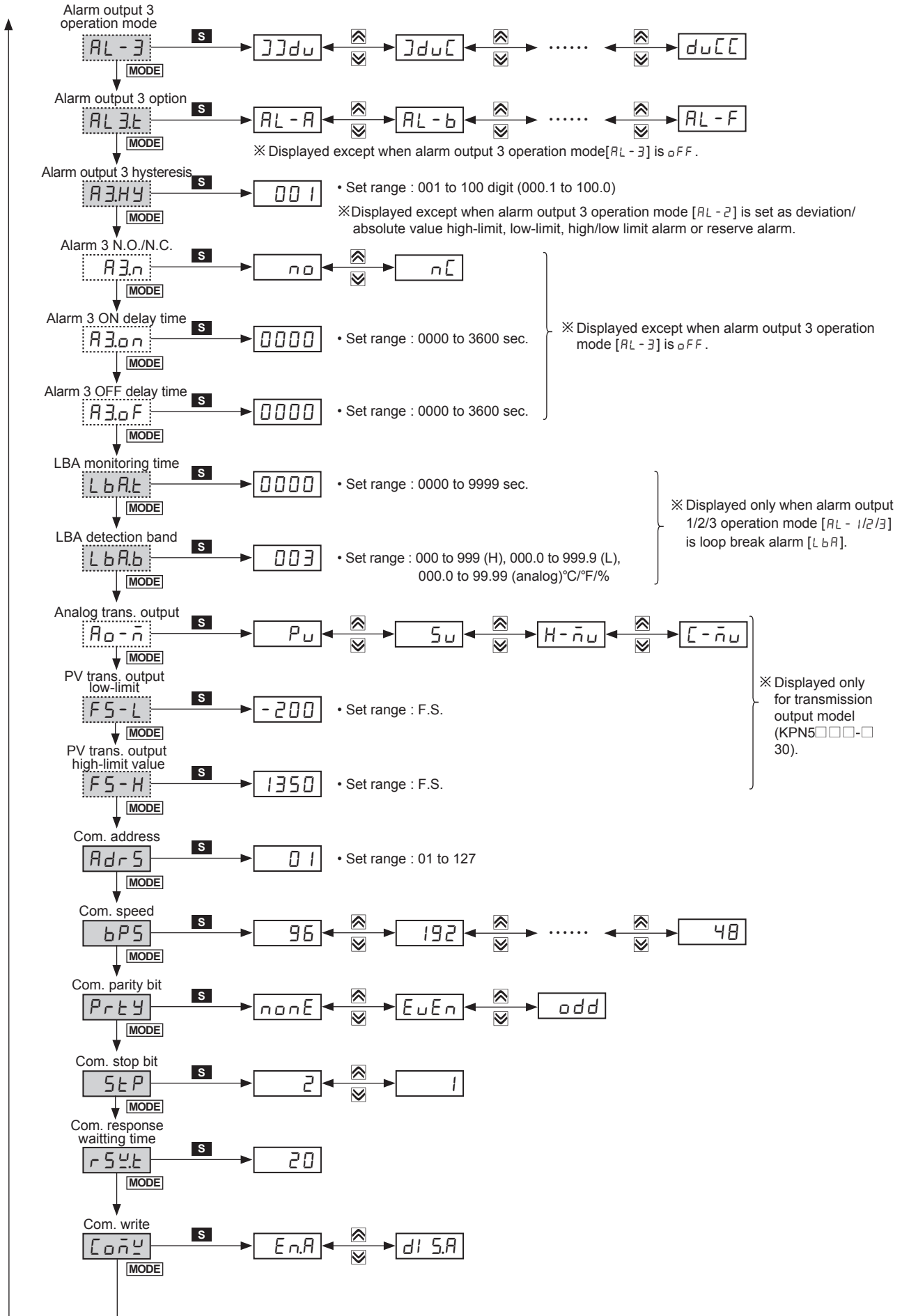

A. Recorders
B. Indicators
C. Converters
<b>D. Controllers</b>
E. Thyristor units
F. Pressure transmitters
G. Temperature transmitters
H. Accessories

KPN

# KPN Series

## Parameter 5 group

- ※1: **S** : Press any key among  $\leftarrow$ ,  $\rightarrow$ ,  $\uparrow$ ,  $\downarrow$
- ※After entering setting mode, press **MODE** key anytime for 3 sec. to return to Run mode.
- ※After entering setting mode, press **MODE** key anytime for 1.5 sec. to go to the concerned group name.
- ※If you press the **MODE** key after changing the setting value of the parameter the setting value will be stored.
- ※   Shaded parameters are for standard-level users, the others are for high-level users.  
(You can set the user level in parameter 5 group)
- ※   This parameter might not be displayed depending on other parameter settings.

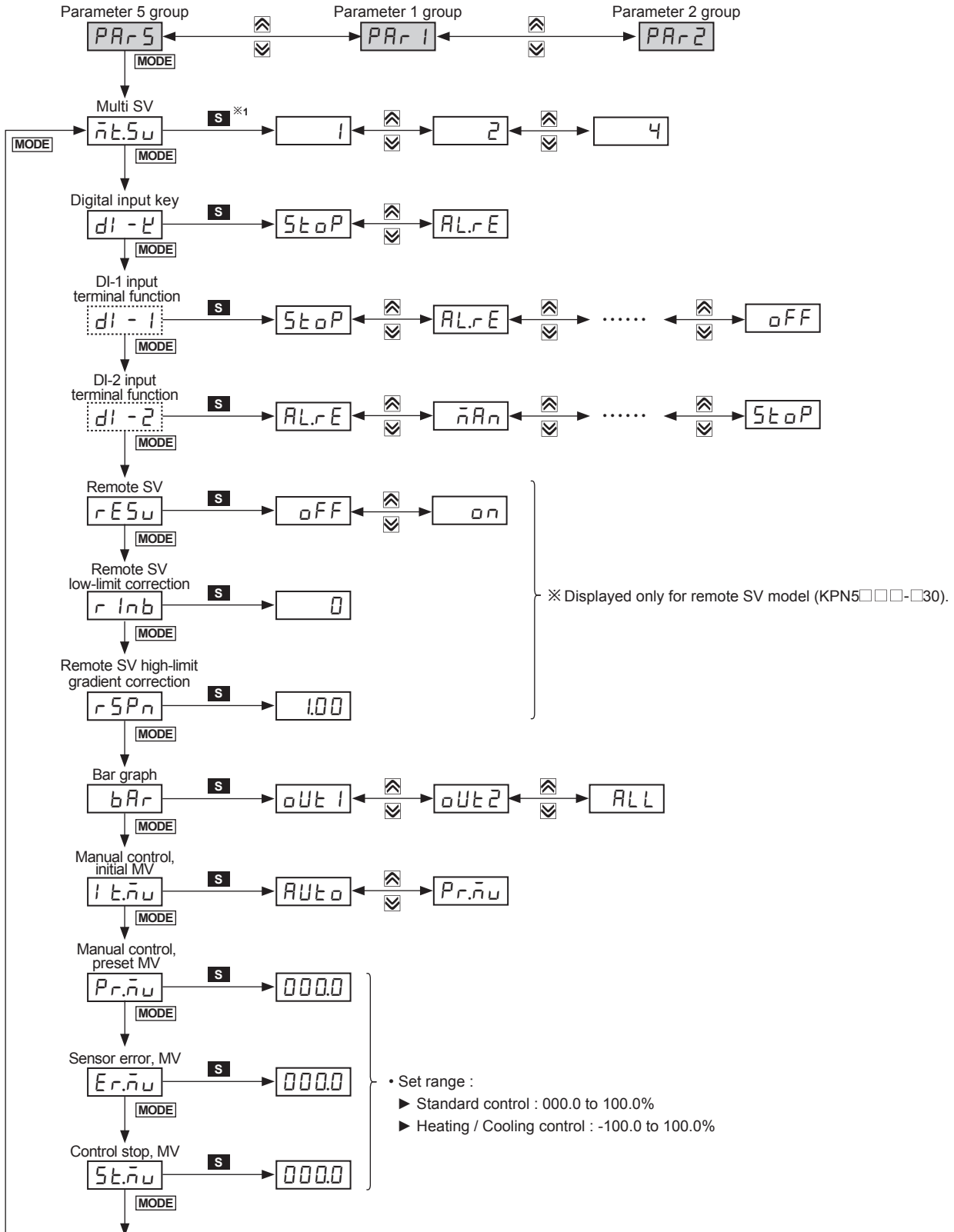



# High Performance & Accuracy Process Controller

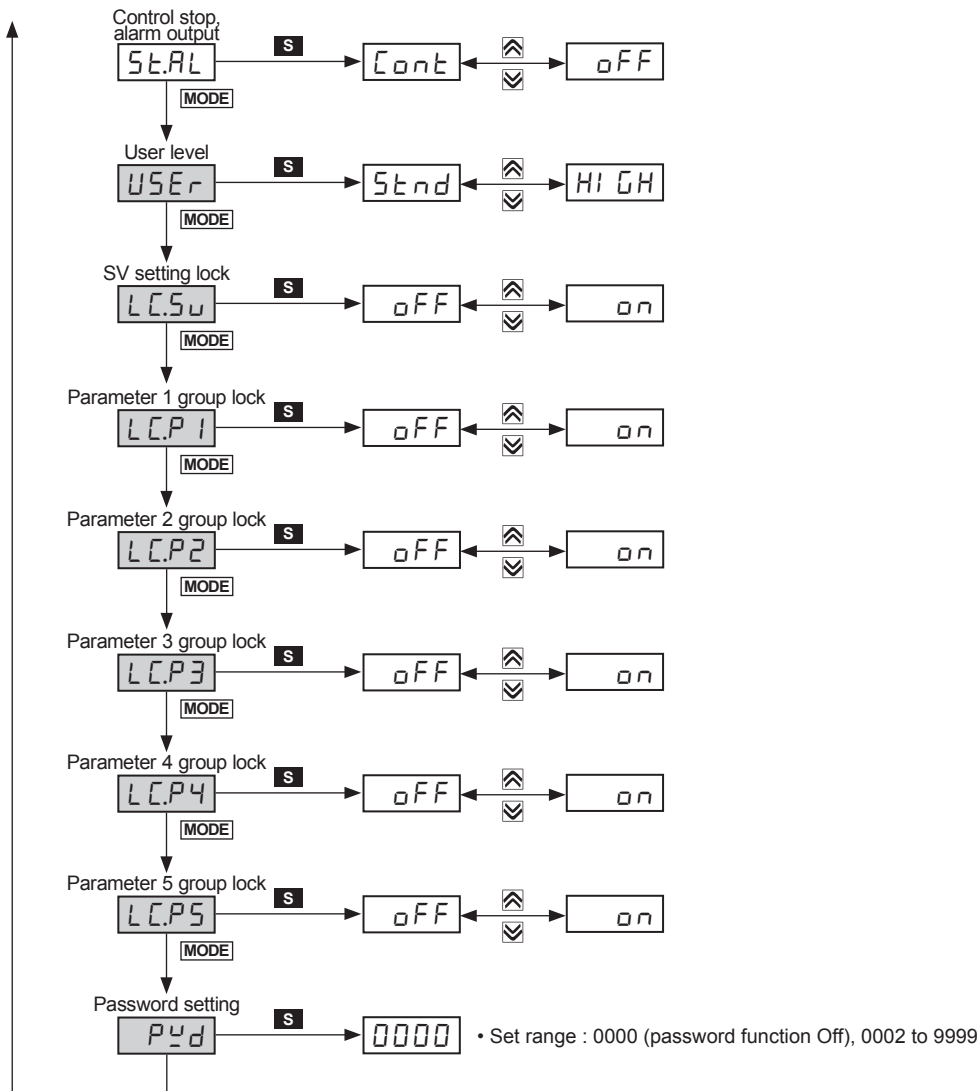

A. Recorders
B. Indicators
C. Converters
<b>D. Controllers</b>
E. Thyristor units
F. Pressure transmitters
G. Temperature transmitters
H. Accessories

KPN

# KPN Series

## Factory default

### SV setting [ S<sub>V</sub> ]

Parameter	Default
S <sub>V</sub>	0

### Password input parameter

Parameter	Default
PASS	0001

### Parameter 1 group [ PAr 1 ]

Parameter	Default	Parameter	Default	Parameter	Default	Parameter	Default
r-S	rUn	AL 1L	1550	AL 3L	0000	S <sub>V</sub> -2	0000
S <sub>V</sub> -n	S <sub>V</sub> -0	AL 1H	1550	AL 3H	0000	S <sub>V</sub> -3	0000
Ct-A	00	AL 2L	1550	S <sub>V</sub> -0	0000		
AL 1L	1550	AL 2H	1550	S <sub>V</sub> -1	0000		

### Parameter 2 group [ PAr 2 ]

Parameter	Default	Parameter	Default	Parameter	Default	Parameter	Default
At	oFF	H-d	0000	H.oSt	000	rAnU	000
H-P	0 100	C-d	0000	CHYS	002	rAnd	000
C-P	0 100	db	0000	C.oSt	000	rUnt	nIn
H-1	0000	rEst	0500	L-nu	-1000		
C-1	0000	HHYS	002	H-nu	1000		

### Parameter 3 group [ PAr 3 ]

Parameter	Default	Parameter	Default	Parameter	Default	Parameter	Default
In-t	ECRH	H-SC	1000	o-ft	HEAt	o 1nA	55r
Unit	oC	dUnt	oPo		H-C		4-20
L-rG	0000	In-b	0000	C-nd	PI d	oUt2	55r
H-rG	1000	nAuF	000.1		PP	o2nA	4-20
dot	00	L-S <sub>V</sub>	-200	At.t	tUn1	H-t	0200 (Relay)
L-SC	0000	H-S <sub>V</sub>	1350	oUt 1	rLY	C-t	0000 (SSR drive)

### Parameter 4 group [ PAr 4 ]

Parameter	Default	Parameter	Default	Parameter	Default	Parameter	Default	Parameter	Default
AL-1	dUCC	AL-2	UJdu	AL-3	LbA	LbAt	0000	bPS	96
AL 1t	AL-A	AL 2t	AL-A	AL 3t	AL-A	LbAb	002	Prty	nonE
A 1HY	001	A 2HY	001	A 3HY	001	Aon	Pu	StP	2
A 1n	no	A 2n	no	A 3n	no	FSL	-200	rStt	20
A 1on	0000	A 2on	0000	A 3on	0000	FSh	1350	CoNy	EnA
A 1oF	0000	A 2oF	0000	A 3oF	0000	AdrS	01		

### Parameter 5 group [ PAr 5 ]

Parameter	Default	Parameter	Default	Parameter	Default	Parameter	Default
n.t.S <sub>V</sub>	1	rSPn	1000	Stnu	0000	LCP3	oFF
dl-t	StoP	bAr	oUt 1	StAL	Cont	LCP4	oFF
dl-1	oFF		ALL	USEr	Stnd	LCP5	oFF
dl-2	oFF	1.t.nu	AUto	LCS <sub>V</sub>	oFF	PYd	0000
rES <sub>V</sub>	oFF	Pr.nu	0000	LCP 1	oFF		
rInb	0000	Er.nu	0000	LCP2	oFF		

※ Shaded parameters are factory defaults for the heating & cooling model.

# High Performance & Accuracy Process Controller

## Functions

### Alarm operation

Mode	Name	Operation	Description
$\alpha FF$	—	—	No alarm output
$d\cup\llcorner\llcorner$	Deviation high-limit alarm	<p>High deviation : Set as 10°C      High deviation : Set as -10°C</p>	If deviation between PV and SV as high-limit is higher than set value of deviation temperature, the alarm output will be ON.
$\llcorner\llcorner d\cup$	Deviation low-limit alarm	<p>Low deviation : Set as 10°C      Low deviation : Set as -10°C</p>	If deviation between PV and SV as low-limit is higher than set value of deviation temperature, the alarm output will be ON.
$\llcorner d\cup\llcorner$	Deviation high/low-limit alarm	<p>Low deviation : Set as 10°C , High deviation : Set as 20°C</p>	If deviation between PV and SV as high/low-limit is higher than set value of deviation temperature, the alarm output will be ON.
$\llcorner d\cup\llcorner$	Deviation high/low-limit reserve alarm	<p>Low deviation : Set as 10°C , High deviation : Set as 20°C</p>	If deviation between PV and SV as high/low-limit is higher than set value of deviation temperature, the alarm output will be OFF.
$P\cup\llcorner\llcorner$	Absolute value high limit alarm	<p>Absolute value alarm : Set as 90°C      Absolute value alarm : Set as 110°C</p>	If PV is higher than the absolute value, the output will be ON.
$\llcorner\llcorner P\cup$	Absolute value low limit alarm	<p>Absolute value alarm : Set as 90°C      Absolute value alarm : Set as 110°C</p>	If PV is lower than the absolute value, the output will be ON.
$LbA$	Loop break alarm	—	It will be ON when it detects loop break.
$SbA$	Sensor break alarm	—	It will be ON when it detects sensor disconnection.
$HbA$	Heater break alarm	—	It will be ON when CT detects heater break.

※ H : alarm output □ hysteresis [A□HY]

### Alarm option

Mode	Name	Description
$AL - A$	Standard alarm	If it is an alarm condition, alarm output is ON. If it is a clear alarm condition, alarm output is OFF.
$AL - b$	Alarm latch	If it is an alarm condition, alarm output is ON and maintains ON status.
$AL - \llcorner$	Standby sequence 1	First alarm condition is ignored and from second alarm condition, standard alarm operates. When power is supplied and it is an alarm condition, this first alarm condition is ignored and from the second alarm condition, standard alarm operates.
$AL - d$	Alarm latch and standby sequence 1	If it is an alarm condition, it operates both alarm latch and standby sequence. When power is supplied and it is an alarm condition, this first alarm condition is ignored and from the second alarm condition, alarm latch operates.
$AL - E$	Standby sequence 2	First alarm condition is ignored and from second alarm condition, standard alarm operates. When re-applied standby sequence and if it is alarm condition, alarm output does not turn ON. After clearing alarm condition, standard alarm operates.
$AL - F$	Alarm latch and standby sequence 2	Basic operation is same as alarm latch and standby sequence 1. If it operates not only by power ON/OFF, but also alarm setting value, or alarm option changing. When re-applied standby sequence and if it is alarm condition, alarm output does not turn ON. After clearing alarm condition, alarm latch operates.

※ Condition of re-applied standby sequence for standby sequence 1, alarm latch and standby sequence 1: Power ON

Condition of re-applied standby sequence for standby sequence 2, alarm latch and standby sequence 2: Power ON, changing set temperature, alarm temperature[AL 1, AL 2] or alarm operation [AL - 1, AL - 2], switching STOP mode to RUN mode.

A. Recorders

B. Indicators

C. Converters

D. Controllers

E. Thyristor units

F. Pressure transmitters

G. Temperature transmitters

H. Accessories

KPN

# KPN Series

## Control output mode [ $\alpha$ -F $\epsilon$ ]

- Control output modes for general temperature control include heating, cooling, and heating/cooling.
- Heating control (reverse operation) and cooling control (normal operation) are mutually opposing operations with inverse outputs.
- The PID time constant varies based on the controlled objects during PID control.

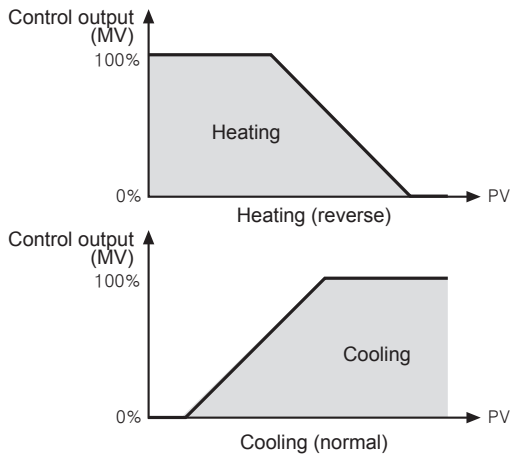

Group	Parameter	Set range	Default	Unit
PAR3	$\alpha$ -F $\epsilon$	Standard model HEA $\epsilon$ /C $\alpha$ $\alpha$ L	HEA $\epsilon$	—
		Heating & Cooling mode HEA $\epsilon$ /C $\alpha$ $\alpha$ L/H-C	H-C	—

## Heating control [ HEA $\epsilon$ ]

The output will be provided in order to supply power to the load (heater) if PV(present temperature) falls below SV(set temperature).

## Cooling control [ C $\alpha$ $\alpha$ L ]

The output will be provided in order to supply power to the load (cooler) if PV(present temperature) rises above SV(set temperature)

## Heating/Cooling control [ H-C ]

Heating and Cooling with a controller when it is difficult to control subject temperature with only heating or cooling. Heating and cooling control mode controls the object using different PID time constants for each heating and cooling. It is also possible to set heating and cooling control in both PID control or ON/OFF control mode. Heating/cooling output can be selected among Relay output, SSR drive output and current output depending on model types chosen according to your application environment. (Note that only standard SSR control is available for SSR drive output in OUT2.)

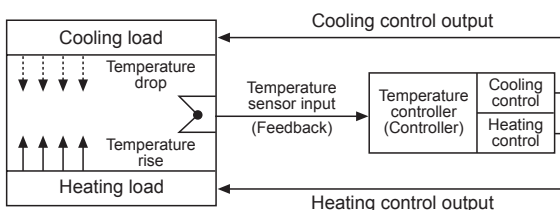

※ For heating and cooling control, OUT1 control output is dedicated to heating control and OUT2 control output to cooling control.

## Auto-tuning [ A $\epsilon$ ]

In PID control, auto-tuning processes the control subject's thermal characteristics and thermal response rate at the controller, and then determines the necessary PID time constant. Application of the PID time constant realizes fast response and high precision temperature control.

- Auto-tuning automatically stores PID time constants upon termination. These PID time constants can then be modified by the user to suit their usage environment.
- When auto-tuning is in progress, the AT lamp located on the front of the controller flashes in 1 second intervals. When auto-tuning finishes, the AT lamp automatically goes off and the auto-tuning parameter will return to OFF.

SV	Description
$\alpha$ FF	Auto-tuning stops
$\alpha$ n	Auto-tuning starts

Group	Parameter	Set range	Default	Unit
PAR2	A $\epsilon$	$\alpha$ FF/ $\alpha$ n	$\alpha$ FF	—

※ Manual interruption or a sensor break error when auto-tuning is in progress restores the PID time constant to the value used prior to the auto-tuning session.

※ Auto-tuning continues to run even if the temperature reading exceeds or falls below the input range.

※ When auto-tuning is in progress, parameters can only be referenced and not altered.

※ Auto-tuning is not available in manual control. (Manual Control).

## Control output(OUT1/OUT2) selection [ $\alpha$ U $\epsilon$ 1 / $\alpha$ U $\epsilon$ 2 ]

- The 1 output type (OUT1) model supports relay output, current output, SSR drive output.
- The 2 output type (OUT1, OUT2) model supports relay output fixed or current output, SSR drive output.

## Parameter mask

This function is able to hide unnecessary parameters to user environment or less frequently used parameters in parameter setting group. You can set this in the integrated device management program (DAQMaster).

Though masked parameters are not displayed in parameter setting group, the parameter setting values are applied. For more information, refer to the DAQMaster user manual. Visit our website ([www.autonics.com](http://www.autonics.com)) to download the DAQMaster program and the user manual.

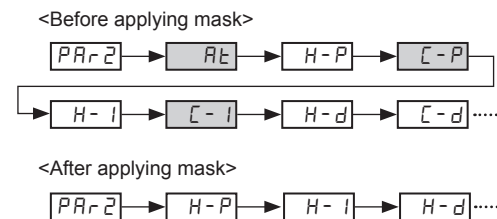

The above is masking auto tuning [ A $\epsilon$  ], cooling proportional band [ C-P ], cooling integral time [ C-I ], cooling derivative time [ C-d ] parameters in parameter 2 group.

# High Performance & Accuracy Process Controller

## ■ User parameter group [PAR-U]

This function is able to set the frequently used parameters to the user parameter group.

You can quickly and easily set parameter settings. User parameter group can have up to 30 parameters in the integrated device management program (DAQMaster.) Visit our website ([www.autonics.com](http://www.autonics.com)) to download the DAQMaster program and the user manual.

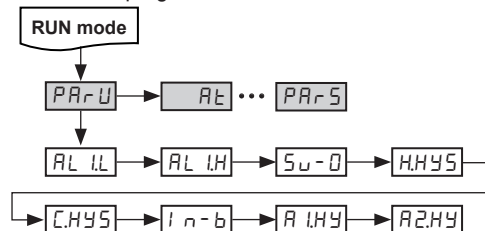

The above is setting user parameter group in the DAQMaster with alarm output 1 low-limit value [AL LL], alarm output 1 high-limit value [AL IH], SV-0 set value [SV-0] parameters of parameter 1 group, heating hysteresis [HHYS], cooling hysteresis [CHYS] parameters of parameter 2 group,

input correction [i n - b], parameter of parameter 3 group, alarm output 1 hysteresis [R IHY], alarm output 2 hysteresis [R2HY] parameters of parameter 4 group.

## ■ Bar graph

MV of control output (OUT1, OUT2) is displayed as the bar graph in real-time. According to bar graph setting [b a r] in parameter 5 group, it displays bar graph by control output or does not display it.

OUT1 (red LED)  
OUT2 (green LED)

One LED is 10% (total 10 LEDs: 100%). If control output MV is 0.1 to 10%, one LED turns ON. If MV is 90.1 to 100%, 10 LEDs turn ON.

The 1 output type (heating or cooling control) model has one OUT1 bar graph (red).

The 2 output type (heating & cooling control) model has two bar graphs; OUT1 bar graph (red), OUT2 bar graph (green). OUT1 is for heating MV and OUT2 is for cooling MV.

## ■ Remote SV setting

This function is to set SV by inputting analog (DC4-20 mA, 1-5 VDC) signal to no. 13 and 14 terminals. (Set that remote SV [r E S U] is ON in parameter 5 group)

Input analog signal is changed to between SV low-limit value [L - S U] to SV high-limit value [H - S U].

※ When using remote SV, you cannot select SV setting by front keys and multi SV setting by digital input.

## ■ Parameter initialization

It initializes all parameters to factory default values. Press the front ++ keys for 5 sec. at the same time and [i n i t] parameter is displayed. Select 'YES' to initialize all parameters.

If the password is set, you must enter the password. After initializing the parameters, the password parameter is also initialized.

※ ■ Refer to the KPN user manual for more functions.

## Proper usage

### ■ Simple troubleshooting for process controller

#### ● When the load (Heater etc) is not operated

Please check operation of the out indicator located in front panel of the unit. If the indicator does not operate, please check the parameter of all programmed mode. If the indicator is operating, please check the output (Relay, SSR drive, DC4-20mA current) after separating output line from the unit.

#### ● When it displays aPE n during operation

This is a warning that external sensor is cut off (open). Please turn off power and check the state of sensor. If sensor is not cut off (open), disconnect sensor line from terminal block and +, - together. When you turn on power it can check room temperature.

If this unit cannot indicate room temperature, this unit itself is faulty. Please remove this unit from equipment and service or replace.

(When the input mode is thermocouple, it is available to indicate room temperature.)

#### ● In case of indicating "Error" in display

This Error message is indicated in case of damaging inner chip program data by outer strong noise.

In this case, please send the unit to our after service center after removing the unit from system.

Noise protection is designed in this unit, but it does not stand up strong noise continuously.

If bigger noise than specified(Max. 2kV) flows in the unit, it can be damaged.

### ■ Caution for using

- Do not use the unit outdoors. Failure to follow this instruction may result in shortening the life cycle of the unit.
- The connection of this unit should be separated from the power line and high voltage line in order to prevent inductive noise.
- Install a power switch or a circuit breaker to supply or cut off the power.
- Switch or circuit breaker should be installed nearby users for convenient control.
- This unit is designed for temperature controlling only. Do not apply this unit as a voltage meter or a current meter.
- In case of using RTD sensor, 3-wire type must be used. If you need to extend the line, use 3-wire with the same thickness as the line. It might cause temperature difference if the resistance of line is different.
- In case of making power line and input signal line closely, line filter for noise protection should be installed at power line and input signal line should be shielded.
- Do not use this unit near the high frequency instruments (high frequency welding machine & sewing machine, large capacity SCR controller).
- Installation environment
  - ① It shall be used indoors.
  - ② Altitude max. 2,000m
  - ③ Pollution degree 2
  - ④ Installation category II

A. Recorders
B. Indicators
C. Converters
D. Controllers
E. Thyristor units
F. Pressure transmitters
G. Temperature transmitters
H. Accessories

KPN