

Small Emitter/Receiver Synchronizing Type

■ Features

- Small size: W12×H16×D30mm
- Minimize malfunction by extraneous light by synchronizing emitter and receiver
- Reverse power polarity and overcurrent protection circuit
- Fast response speed: Max. 1ms

 Please read "Caution for your safety" in operation manual before using.

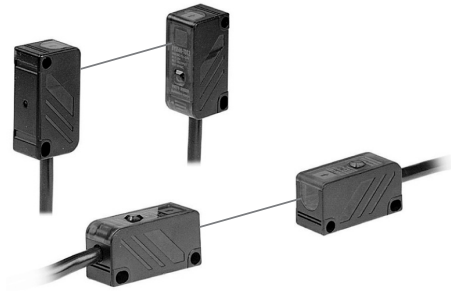

■ Specifications

Model	Standard type		Side sensing type	
	BY500-TDT		BYS500-TDT	
Sensing type	Through-beam			
Sensing distance	500mm			
Sensing target	Opaque materials of min. Ø5mm			
Response time	Max. 1ms			
Power supply	12-24VDC ±10% (Ripple P-P: Max. 10%)			
Current consumption	Max. 30mA			
Light source	Infrared LED (940nm)			
Operation mode	Dark ON			
Control output	NPN open collector output • Load voltage: 30VDC • Load current: Max. 100mA • Residual voltage: Max. 1V			
Protection circuit	Reverse polarity protection, output short-circuit protection			
Indicator	Operation indicator: red LED			
Insulation resistance	Min. 20MΩ (at 500VDC megger)			
Noise resistance	±240V the square wave noise (pulse width: 1μs) by the noise simulator			
Dielectric strength	1,000VAC 50/60Hz for 1minute			
Vibration	1.5mm amplitude at frequency of 10 to 55Hz (for 1 min.) in each X, Y, Z direction for 2 hours			
Shock	500m/s ² (approx. 50G) in each X, Y, Z direction for 3 times			
Environment	Ambient illumination	Sunlight: Max. 11,000lx Incandescent lamp: Max. 3,000 lx (Receiving illumination)		
	Ambient temperature	-10 to 60°C, storage: -25 to 70°C		
	Ambient humidity	35 to 85%RH, storage: 35 to 85%RH		
Protection structure	IP50 (IEC standard)			
Material	Case: ABS, Sensing part: Acrylic			
Cable	Ø4mm, 4-wire, Length: 2m (Emitter of through-beam type: Ø4mm, 3-wire, Length: 2m) (AWG22, Core diameter: 0.08mm, Number of cores: 60, Insulator out diameter: Ø1.25mm)			
Accessories	Mounting bracket, Bolts/Nuts			
Unit weight	Approx. 150g			

※The temperature or humidity mentioned in Environment indicates a non freezing or condensation environment.

(A) Photoelectric Sensors

(B) Fiber Optic Sensors

(C) Door/Area Sensors

(D) Proximity Sensors

(E) Pressure Sensors

(F) Rotary Encoders

(G) Connectors/ Sockets

(H) Temperature Controllers

(I) SSRs / Power Controllers

(J) Counters

(K) Timers

(L) Panel Meters

(M) Tacho / Speed / Pulse Meters

(N) Display Units

(O) Sensor Controllers

(P) Switching Mode Power Supplies

(Q) Stepper Motors & Drivers & Controllers

(R) Graphic/ Logic Panels

(S) Field Network Devices

(T) Software

BY Series

Feature Data

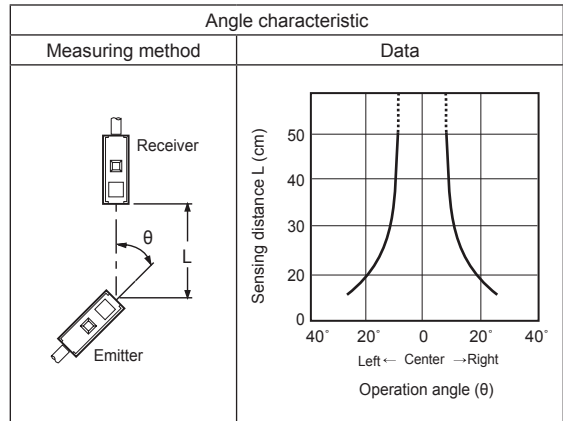
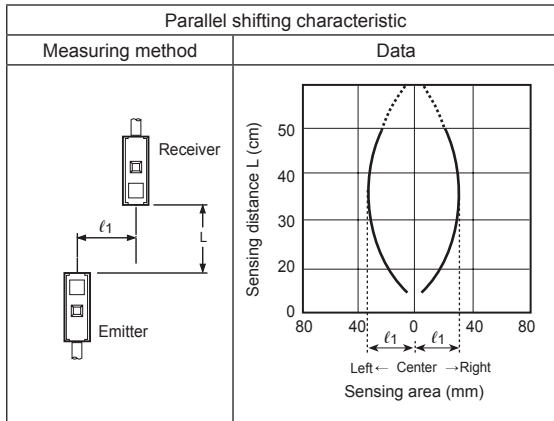

Control Output Diagram

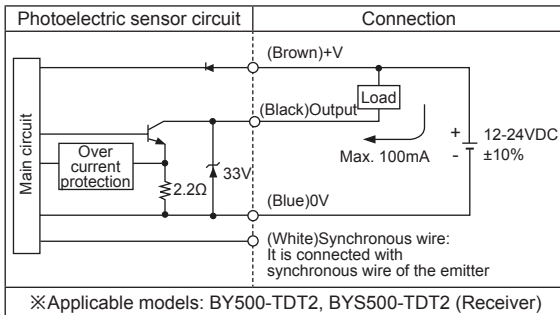

Operation Mode

Operation mode	Dark ON
Receiver operation	<p>Received light: [Pulse]</p> <p>Interrupted light: [Pulse]</p>
Operation indicator (red LED)	<p>ON: [Pulse]</p> <p>OFF: [Pulse]</p>
Transistor output	<p>ON: [Pulse]</p> <p>OFF: [Pulse]</p>

※If the control output terminal is short-circuited or overcurrent condition exists, the control output turns OFF due to protection circuit.

※Please supply the power to the brown and the blue wires of the emitter and Synchronous wire (white) of the receiver must be connected with that of the emitter.

Connections

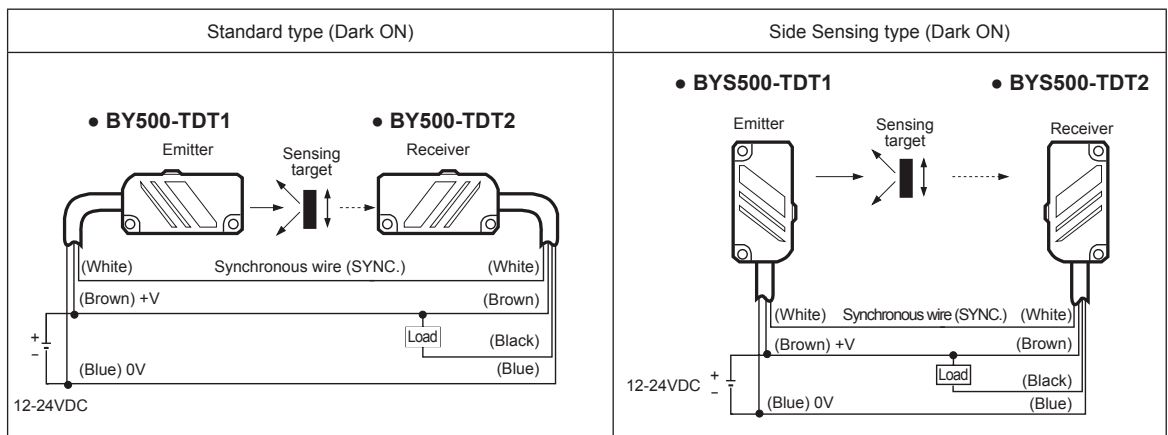

※The power of the emitter and the receiver must be supplied from the same power line.

※Synchronous wire (white) of the receiver must be connected with that of the emitter, or it may cause malfunction.

Small And Amplifier Built-in Type

■ Dimensions

(unit: mm)

● BY500-TDT

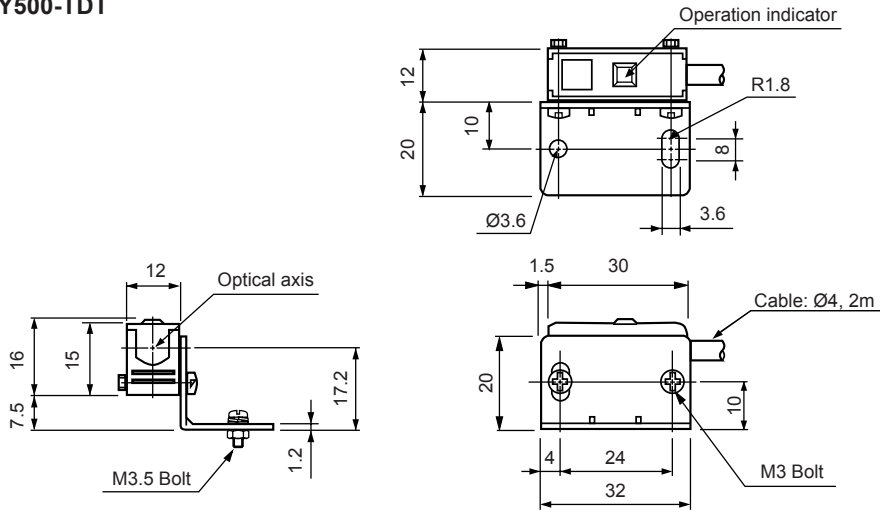

● BY500-TDT

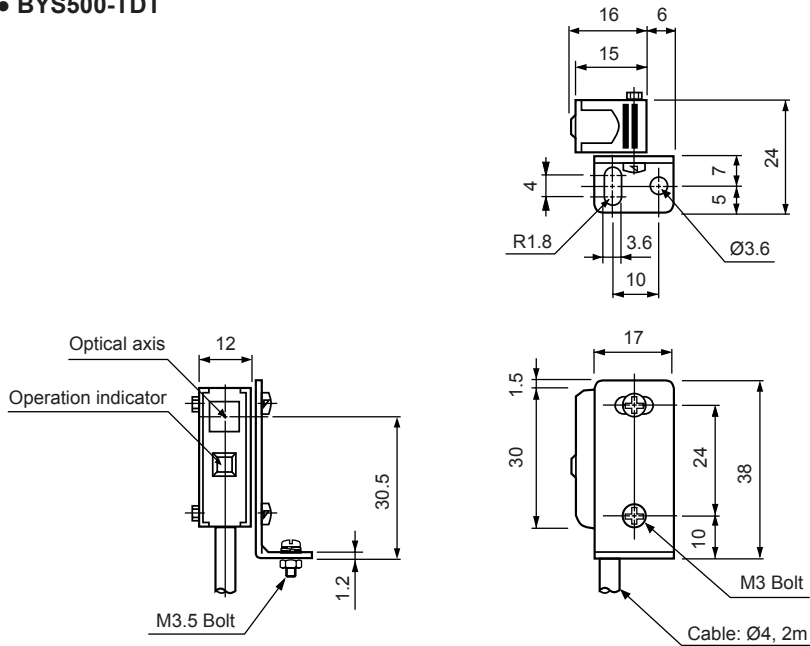

■ Mounting And Sensitivity Adjustment

1. Supply the power to the sensor, after installing the emitter and the receiver facing each other.
 2. Set the receiver in the middle of position where the operation indicator turns ON adjusting the receiver to the right and the left or up and down.
 3. Fix both units tightly after checking that the unit detects the target.
- ※If a sensing target is translucent body or smaller than Ø5mm, it might not be detected because the because light penetrate it.

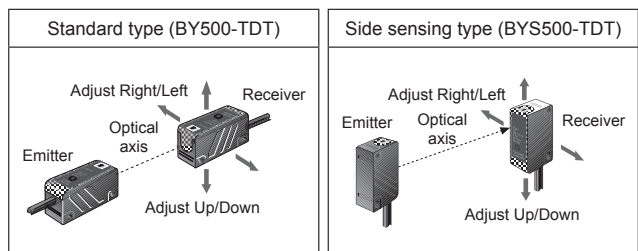

(A)	Photoelectric Sensors
(B)	Fiber Optic Sensors
(C)	Door/Area Sensors
(D)	Proximity Sensors
(E)	Pressure Sensors
(F)	Rotary Encoders
(G)	Connectors/Sockets
(H)	Temperature Controllers
(I)	SSRs / Power Controllers
(J)	Counters
(K)	Timers
(L)	Panel Meters
(M)	Tacho / Speed / Pulse Meters
(N)	Display Units
(O)	Sensor Controllers
(P)	Switching Mode Power Supplies
(Q)	Stepper Motors & Drivers & Controllers
(R)	Graphic/ Logic Panels
(S)	Field Network Devices
(T)	Software