

# PSD-100 Series

## FEATURES

- High Efficiency
- 100% Full Load Burn-In
- Low Ripple & Noise
- Adjustable DC Voltage Output
- Class II Isolation Level
- UL62368-1 and CAN / CSA C22.2
- Protections: Overload / Over Voltage / Short Circuit
- Three-year Warranty

**Low Profile**

- Small size
- Universal input
- Three-year Warranty



Input: 90-264V AC; 50/60HZ  
Output Voltage: 5V-48V DC  
Rated Power: 100W max.



## CATALOG NUMBER

**PSD-10012**

**PSD-10015**

**PSD-10024**

**PSD-10048**

## INPUT

Input Voltage	90-264VAC			
Input Frequency	47-63Hz			
Inrush Current	35Amps max. at 115VAC/60Hz, Full Load & 70Amps max. at 240VAC/50Hz, Full Load			
AC Current	3A/115VAC 1.6A/230VAC			
Leakage Current (MAX)	<0.25mA/240VAC			
Efficiency	88%	89%	90%	90%

## OUTPUT

DC Voltage	12V	15V	24V	48V
Rated Current	7.1A	6.13A	3.8A	2.1A
Rated Power	86W	92W	91W	100W
Ripple and Noise	120mVp-p	120mVp-p	150mVp-p	240mVp-p
Line Regulation	±1%			
Load Regulation	±1%			
Setup, Rise, Hold Up Time	500mS/ 60mS/ 12mS (115V/60HZ MAX ROAD) 500mS/ 60mS/ 30mS (230V/50HZ MAX ROAD)			

## ENVIRONMENTAL

Operating Temperature	-20°C to 50°C, Full Load, Normal Operation.
Storage Temperature	-40°C to 80°C
Storage Humidity	10 ~ 95% RH
Working Humidity	20% ~ 90% RH Non-Condensing

## PROTECTIONS

Overload Protection	>130%-200% Rated Output Power Protection type: Hiccup Mode- recovers automatically after fault condition is removed
Over Voltage Protection	110~145% Protection Type: Clamp by Zener diode
Short Circuit Protection	Protection to Zero Voltage
Over Current Protection	110%-180%

## SAFETY & EMC

Safety Regulations	UL60950-1, UL508, BSMI CNS14336-1, TUV EN61558-2-16 IEC60950-1, EAC TPTC 004, TUV EN60950-1 UL62368-1 and CAN / CSA C22.2 No.62368-1-14
Withstand Voltage	I/P-O/P: 3KVAC
Isolation Resistance	I/P-O/P: 100M Ohms / 500VDC / 25 / 70% RH
EMC Emission	EN55032 (CISPR32), CNS13438 Class B, EN61000-3-2 Class A, EN61000-3-3, EN61000-4-2,3,4,5,6,8,11, EN55024, EN55035, EN61000-6-2, EN61204-3

## OTHER

MTBF	200,000 Hours Minimum at Full Load at 25°C Ambient
Size	90 x 70 x 58mm
Weight	270g / pcs
Packaging	50 PCS/CTN

For the latest on Altech Power Supply specifications please visit [www.altechcorp.com/power](http://www.altechcorp.com/power).

## Mechanical Specification

Pin #	Assignment	Pin #	Assignment
1,2	-V	5	AC / L
3,4	+V	6	AC / N
O	Voltage adjuster		

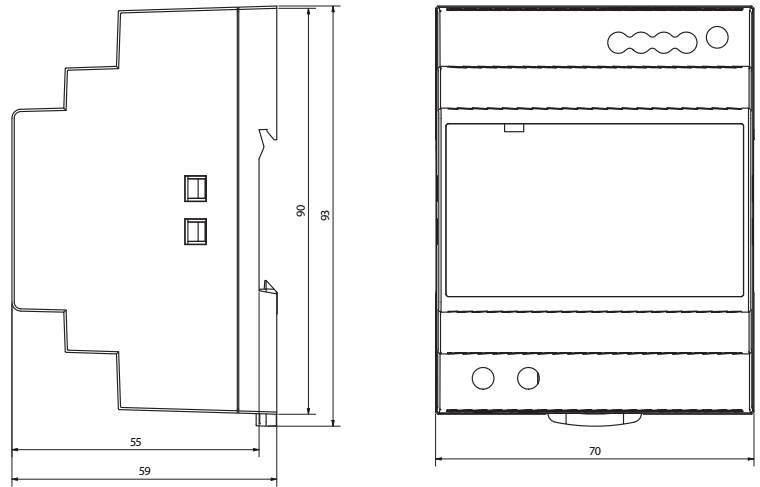

## Block Diagram

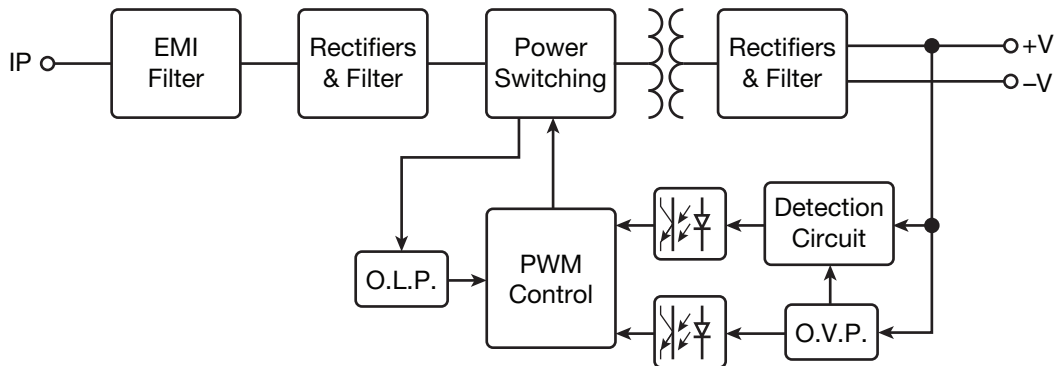

**Deduction Curve and Temperature:**

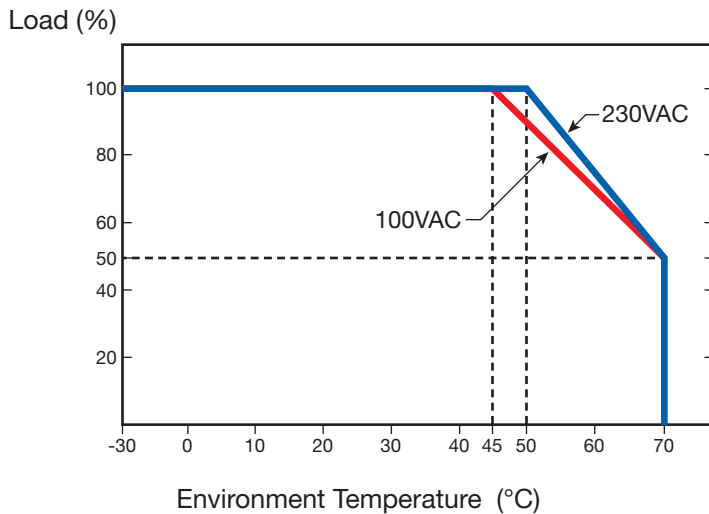

**Minus Output and Input Voltage Curves:**

